



Model created in COMSOL Multiphysics 6.4

Surface Micromachined Accelerometer

Introduction

This example shows how to model a surface micromachined accelerometer in COMSOL, using the **Electromechanics** interface. The example is based on the case study in [Ref. 1](#). The model also demonstrates the use of linked subsequences. A collection of geometric building blocks can be stored in a source model file as subsequences. Thereafter, other model files can reuse the same building blocks by linking to the subsequences in the source model file. Each subsequence can take arguments to generate a building block with specific dimensions or number of features. In this model, a surface micromachined accelerometer is created from three building blocks, two of which are used multiple times by calling the corresponding subsequence with different arguments.

Model Definition

The surface micromachined accelerometer is composed of a released proof mass supported by anchored springs at its two ends, together with sensing and self test electrodes extending to the sides. When the device is subject to an acceleration, the restoring force from the springs gives a displacement of the proof mass in proportion to the acceleration. The displacement causes a change in the capacitance between the fixed and moving electrodes. This change in capacitance can be measured with a number of standard circuits.

For acceleration along the axis of the accelerometer, symmetry allows modeling only half of the geometry for faster computation. The three geometric building blocks are the proof mass with attached electrodes ([Figure 1](#)), the folded spring ([Figure 2](#)), and the fixed electrode array ([Figure 3](#)). These building blocks are implemented as Subsequences that take arguments to specify dimensions, orientation, position, and number of features. For example, the proof mass shown in [Figure 1](#) has 7 sense electrodes at the center and 3 self test electrodes at each end. The actual model on the other hand is built with 21 sense electrodes, by calling the same Subsequence with the corresponding argument 21. As another example, [Figure 4](#) shows an electrode array built from the same Subsequence as in [Figure 3](#), with a different set of arguments, resulting in different number of electrodes, dimensions, and orientation of the anchor pads.

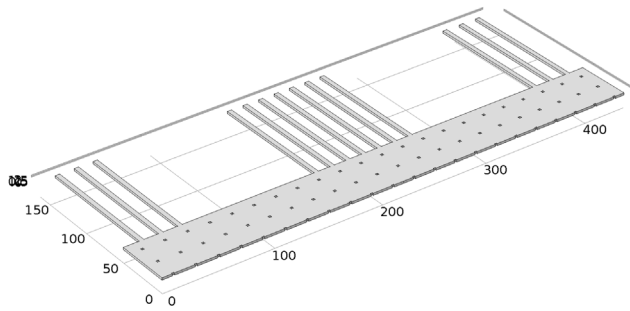

Figure 1: Building block for the proof mass with attached electrodes. Grid scales are in micrometers.

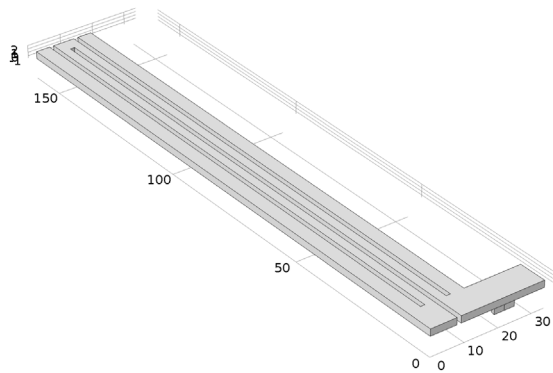

Figure 2: Building block for the folded spring. Grid scales are in micrometers.

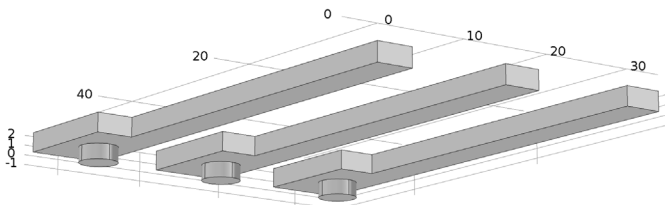

Figure 3: Building block for the fixed electrode array. Grid scales are in micrometers.

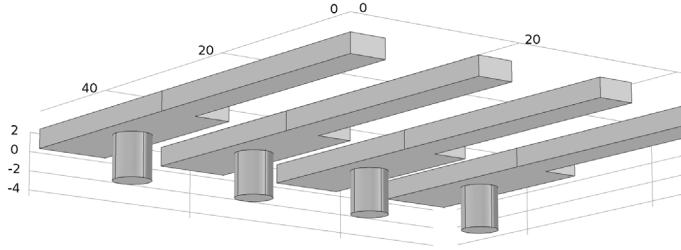

Figure 4: Example of an electrode array built from the same Subsequence as in Figure 3, with a different set of arguments. Grid scales are in micrometers.

The geometry sequence begins by calling the proof mass Subsequence, followed by calling the folded spring Subsequence twice to attach a spring at each end of the proof mass. Subsequently 6 calls to the fixed electrode array Subsequence are made to construct the sense and self test fixed electrodes.

Each Subsequence call contributes to a domain and a boundary selection. This allows easy assignment of domain physics and boundary conditions in the physics interface.

The model uses polysilicon for the building material and includes a rectangular air domain surrounding the polysilicon. The **Electromechanics** multiphysics interface models the electric field within the deforming gaps between the electrodes, and applies the appropriate electrostatic forces to the solids, which creates a corresponding structural deformation. The deformation of the gaps between electrodes results in nonlinear geometrical effects, which are included in the **Electromechanics** multiphysics interface by default.

The entire polysilicon solid is subject to an acceleration using the **Body Load** domain physics feature. The (mechanically) fixed electrodes are set at constant potentials, and the proof mass (and its attached electrodes) is at a floating potential whose value will be determined by the position-dependent capacitance (and the applied voltages on the fixed sense electrodes).

Results and Discussion

The first study illustrates the normal operation of the accelerometer by sweeping the applied acceleration from -50 to +50 g and computing the resulting displacement of the proof mass. Figure 5 shows the displacement of the polysilicon domains when the applied acceleration is 50 g. The proof mass (and the attached moving electrodes) moves by about

0.07 micrometer. The anchored spring bases and the fixed electrodes have very little movement. The folded springs have varying displacement along its length as expected.

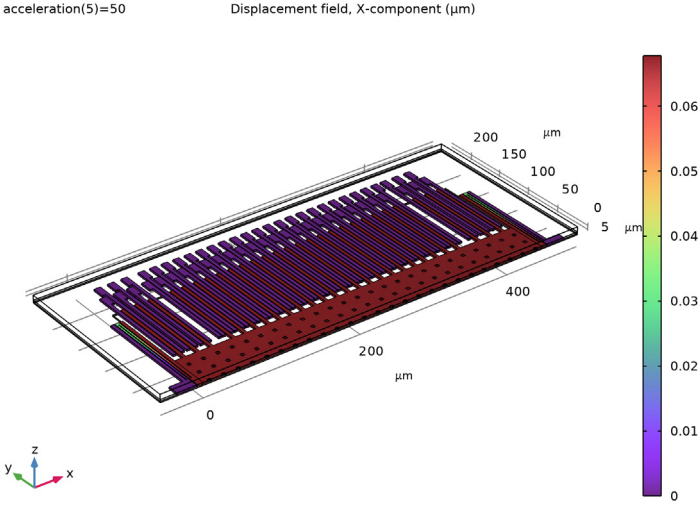

Figure 5: Displacement of the polysilicon domains when the applied acceleration is 50 g. The proof mass moves by about 0.07 micrometer. The anchored spring bases and the fixed electrodes have very little movement. The springs have varying displacement along its length as expected.

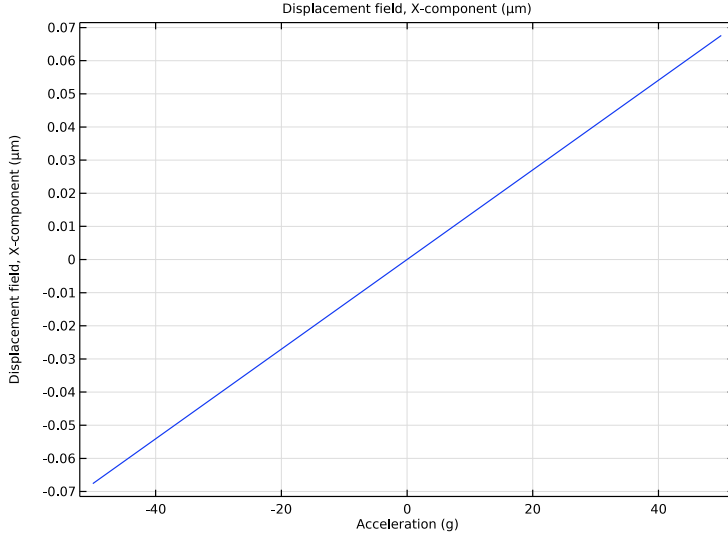

Figure 6: Displacement vs acceleration.

Figure 6 shows the linear relationship between the displacement and the applied acceleration. The displacement is measured via the capacitive coupling between the moving and the fixed sense electrodes. In the real device, during normal operation, the proof mass with its attached moving electrodes is floating at a potential close to one half of the supply voltage, and a high frequency square wave swinging between zero and the full supply voltage is applied with opposite phase to the fixed sense electrodes on each side of the moving electrodes. The fixed self test electrodes are biased at one half of the supply voltage. When the proof mass moves as a result of the acceleration, an alternating voltage in proportion to the displacement is induced due to the capacitive coupling between the fixed and moving electrodes. This arrangement nulls the average electrostatic force between the fixed and moving sense electrodes, and facilitates easier signal processing in the attached circuitry. In this example the stationary part of the square wave is modeled using a stationary study, so that the problem solves relatively quickly. The bias is shifted to zero for convenience, and the amplitude of the square wave is divided by an artificial factor of 1000 to reduce the electrostatic force between the fixed and moving sense electrodes (in practice the time average of the force will be zero due to the high frequency excitation). For a 5 V supply in the physical device, this corresponds to applying a ± 2.5 mV on the right-side and left-side fixed sense electrodes in the model. In postprocessing, the artificial factor of 1000 is multiplied back to the sensed voltage of the proof mass. Figure 7 shows

the linear relationship between the sense voltage and the acceleration. This signal is fed into an amplifier that in the real device was built on the same substrate as the mechanical structure.

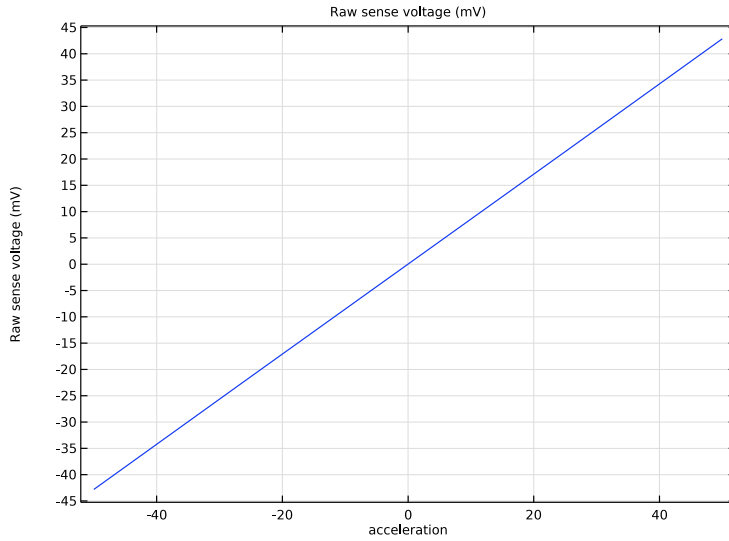

Figure 7: Sensed voltage vs. applied acceleration.

The accelerometer in the model was designed with self test electrodes that could be employed to calibrate the device in the factory. The second study illustrates the self testing by applying a bias of 2 V on the fixed self test electrodes, which are at the side of the moving electrodes attached to the proof mass. The electric field between the fixed and the moving electrodes exerts an electrostatic force that causes the proof mass to move.

[Figure 8](#) shows the displacement of the polysilicon domains when 0 V is applied to the fixed self test electrodes on the left-hand side of the moving electrodes attached to the proof mass, and 2 V to those on the right-hand side. The proof mass moves by about 0.02 μm , which is large enough in magnitude for the self test purpose (compared to the 0.07 μm of full range displacement shown in [Figure 5](#) and [Figure 6](#)).

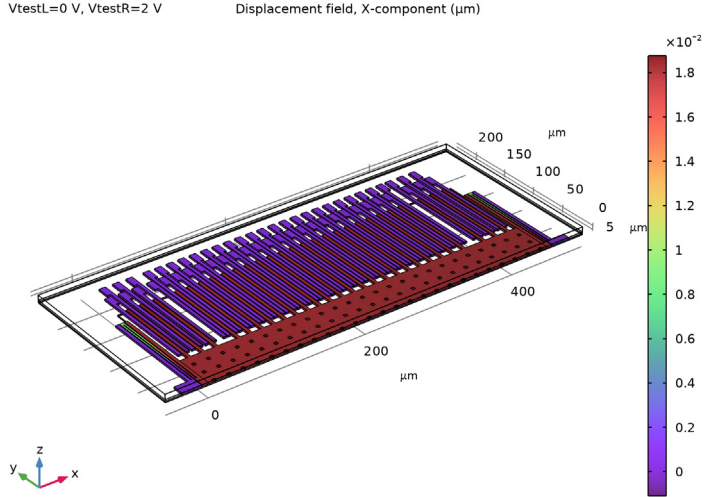

Figure 8: Displacement of the polysilicon domains when 0 V is applied to the fixed self test electrodes on the left side of the moving electrodes attached to the proof mass, and 2 V to those on the right side. The proof mass moved by about $0.02 \mu\text{m}$, which is large enough in magnitude for the self test purpose (compared to the $0.07 \mu\text{m}$ of full range displacement shown in Figure 5 and Figure 6).

Figure 9 compares the displacement obtained from applying the self test voltage to each side of the fixed electrodes. The displacement values have the same magnitude with opposite signs, as expected from symmetry.

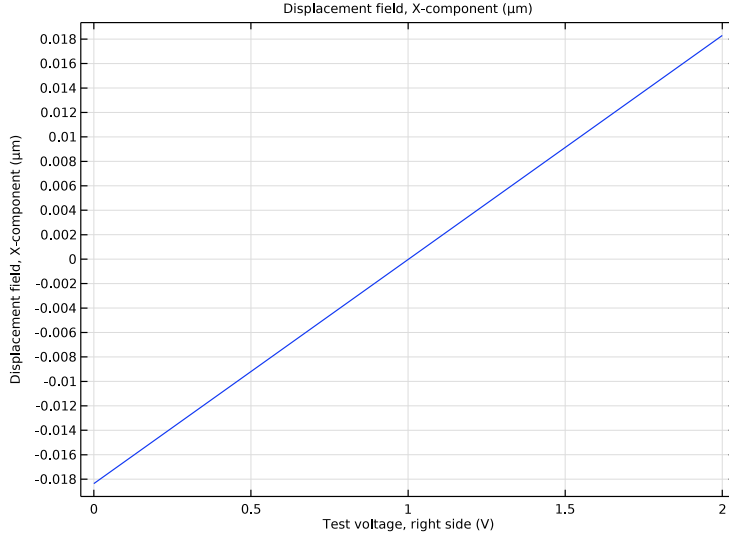

Figure 9: Displacement vs. applied self test voltage.

Reference

1. S.D. Senturia, *Microsystem Design* 5th ed., Kluwer Academic Publishers, pp. 513–525, 2003.

Application Library path: MEMS_Module/Sensors/
surface_micromachined_accelerometer

Modeling Instructions

ROOT

Load the geometry file.



APPLICATION LIBRARIES

- 1 From the **File** menu, choose **Application Libraries**.
- 2 In the **Application Libraries** window, select **MEMS Module > Sensors > surface_micromachined_accelerometer_geom** in the tree.



- 3 Click  **Open**.

The model geometry has been set up using parts in a linked file. It is easier to visualize with wireframe rendering.

COMPONENT 1 (COMP1)

- 1 Click the  **Wireframe Rendering** button in the **Graphics** toolbar.
- 2 Click the  **Zoom Extents** button in the **Graphics** toolbar.

ADD MATERIAL

- 1 In the **Home** toolbar, click  **Add Material** to open the **Add Material** window.
- 2 Go to the **Add Material** window.
- 3 In the tree, select **MEMS > Semiconductors > Si - Polycrystalline silicon**.
- 4 Right-click and choose **Add to Component 1 (comp1)**.
- 5 In the **Home** toolbar, click  **Add Material** to close the **Add Material** window.

MATERIALS

Si - Polycrystalline silicon (mat1)



- 1 In the **Settings** window for **Material**, locate the **Geometric Entity Selection** section.
- 2 From the **Selection** list, choose **Polysilicon**.

DEFINITIONS

All domains

- 1 In the **Definitions** toolbar, click  **Explicit**.
- 2 In the **Settings** window for **Explicit**, type All domains in the **Label** text field.
- 3 Locate the **Input Entities** section. Select the **All domains** checkbox.

Air

- 1 In the **Definitions** toolbar, click  **Difference**.
- 2 In the **Settings** window for **Difference**, type Air in the **Label** text field.
- 3 Locate the **Input Entities** section. Under **Selections to add**, click  **Add**.
- 4 In the **Add** dialog, select **All domains** in the **Selections to add** list.
- 5 Click **OK**.
- 6 In the **Settings** window for **Difference**, locate the **Input Entities** section.
- 7 Under **Selections to subtract**, click  **Add**.

8 In the **Add** dialog, select **Polysilicon** in the **Selections to subtract** list.

9 Click **OK**.

MOVING MESH

Deforming Domain 1

1 In the **Model Builder** window, expand the **Component 1 (comp1) > Moving Mesh** node, then click **Deforming Domain 1**.

2 In the **Settings** window for **Deforming Domain**, locate the **Domain Selection** section.

3 From the **Selection** list, choose **Air**.

SOLID MECHANICS (SOLID)

1 In the **Model Builder** window, under **Component 1 (comp1)** click **Solid Mechanics (solid)**.

2 In the **Settings** window for **Solid Mechanics**, locate the **Domain Selection** section.

3 From the **Selection** list, choose **Polysilicon**.

Body Load 1

1 In the **Physics** toolbar, click  **Domains** and choose **Body Load**.

2 In the **Settings** window for **Body Load**, locate the **Force** section.

3 Specify the \mathbf{f}_V vector as

acceleration*solid.rho*g_const	x
0	y
0	z

4 Locate the **Domain Selection** section. From the **Selection** list, choose **Polysilicon**.

Fixed Constraint 1

1 In the **Physics** toolbar, click  **Boundaries** and choose **Fixed Constraint**.

2 In the **Settings** window for **Fixed Constraint**, locate the **Boundary Selection** section.

3 From the **Selection** list, choose **Anchor plane**.

Symmetry 1

1 In the **Physics** toolbar, click  **Boundaries** and choose **Symmetry**.

2 In the **Settings** window for **Symmetry**, locate the **Boundary Selection** section.

3 From the **Selection** list, choose **Symmetry plane**.

MOVING MESH

Symmetry/Roller 1

- 1 In the **Model Builder** window, under **Component 1 (comp1) > Moving Mesh** click **Symmetry/Roller 1**.
- 2 In the **Settings** window for **Symmetry/Roller**, locate the **Boundary Selection** section.
- 3 From the **Selection** list, choose **Symmetry plane**.

ELECTROSTATICS (ES)

Charge Conservation in Solids 1

- 1 In the **Model Builder** window, expand the **Component 1 (comp1) > Electrostatics (es)** node, then click **Charge Conservation in Solids 1**.
- 2 In the **Settings** window for **Charge Conservation in Solids**, locate the **Domain Selection** section.
- 3 From the **Selection** list, choose **Polysilicon**.

Ground 1

- 1 In the **Physics** toolbar, click  **Boundaries** and choose **Ground**.
- 2 Select Boundary 45 only.

Sense Terminal L

- 1 In the **Physics** toolbar, click  **Boundaries** and choose **Boundary Terminal**.
- 2 In the **Settings** window for **Boundary Terminal**, type Sense Terminal L in the **Label** text field.
- 3 Locate the **Boundary Selection** section. From the **Selection** list, choose **Sense left boundaries**.
- 4 Locate the **Terminal** section. From the **Terminal type** list, choose **Voltage**.
- 5 In the V_0 text field, type $-2.5[\text{mV}]$.

Sense Terminal R

- 1 In the **Physics** toolbar, click  **Boundaries** and choose **Boundary Terminal**.
- 2 In the **Settings** window for **Boundary Terminal**, type Sense Terminal R in the **Label** text field.
- 3 Locate the **Boundary Selection** section. From the **Selection** list, choose **Sense right boundaries**.
- 4 Locate the **Terminal** section. From the **Terminal type** list, choose **Voltage**.
- 5 In the V_0 text field, type $2.5[\text{mV}]$.

Floating Potential I

- 1 In the **Physics** toolbar, click  **Boundaries** and choose **Floating Potential**.
- 2 In the **Settings** window for **Floating Potential**, locate the **Boundary Selection** section.
- 3 From the **Selection** list, choose **Proof mass boundaries**.

Self Test Terminal L



- 1 In the **Physics** toolbar, click  **Boundaries** and choose **Boundary Terminal**.
- 2 In the **Settings** window for **Boundary Terminal**, type Self Test Terminal L in the **Label** text field.
- 3 Locate the **Boundary Selection** section. From the **Selection** list, choose **Self test left boundaries**.
- 4 Locate the **Terminal** section. From the **Terminal type** list, choose **Voltage**.
- 5 In the V_0 text field, type V_{testL} .

Self Test Terminal R

- 1 In the **Physics** toolbar, click  **Boundaries** and choose **Boundary Terminal**.
- 2 In the **Settings** window for **Boundary Terminal**, type Self Test Terminal R in the **Label** text field.
- 3 Locate the **Boundary Selection** section. From the **Selection** list, choose **Self test right boundaries**.
- 4 Locate the **Terminal** section. From the **Terminal type** list, choose **Voltage**.
- 5 In the V_0 text field, type V_{testR} .

MESH I

Free Triangular I



- 1 In the **Mesh** toolbar, click  **More Generators** and choose **Free Triangular**.
- 2 In the **Settings** window for **Free Triangular**, locate the **Boundary Selection** section.
- 3 From the **Selection** list, choose **Meshing plane**.
- 4 Click  **Build Selected**.

Swept I

In the **Mesh** toolbar, click  **Swept**.

Distribution I



- 1 Right-click **Swept I** and choose **Distribution**.
- 2 In the **Settings** window for **Distribution**, locate the **Domain Selection** section.

- 3 Click  **Clear Selection**.
- 4 Select Domain 3 only.
- 5 Locate the **Distribution** section. In the **Number of elements** text field, type 1.
- 6 Click  **Build All**.

STUDY 1: NORMAL OPERATION

- 1 In the **Model Builder** window, right-click **Study 1** and choose **Rename**.
- 2 In the **Rename Study** dialog, type Study 1: Normal Operation in the **New label** text field.
- 3 Click **OK**.

Step 1: Stationary

- 1 In the **Model Builder** window, expand the **Study 1: Normal Operation** node, then click **Step 1: Stationary**.
- 2 In the **Settings** window for **Stationary**, click to expand the **Results While Solving** section.
- 3 Select the **Plot** checkbox.
- 4 From the **Update at** list, choose **Steps taken by solver**.
- 5 Click to expand the **Study Extensions** section. Select the **Auxiliary sweep** checkbox.
- 6 Click  **Add**.
- 7 Click  **Range**.
- 8 In the **Range** dialog, type -50 in the **Start** text field.
- 9 In the **Step** text field, type 25.
- 10 In the **Stop** text field, type 50.
- 11 Click **Add**.

Solution 1 (sol1)

- 1 In the **Study** toolbar, click  **Show Default Solver**.
- 2 In the **Model Builder** window, expand the **Solution 1 (sol1)** node.
- 3 In the **Model Builder** window, expand the **Study 1: Normal Operation > Solver Configurations > Solution 1 (sol1) > Dependent Variables 1** node, then click **Spatial Mesh Displacement (comp1.spatial.disp)**.
- 4 In the **Settings** window for **Field**, locate the **Scaling** section.
- 5 In the **Scale** text field, type $1e-7$.
- 6 In the **Model Builder** window, under **Study 1: Normal Operation > Solver Configurations > Solution 1 (sol1) > Dependent Variables 1** click **Displacement Field (comp1.u)**.

- 7 In the **Settings** window for **Field**, locate the **Scaling** section.
- 8 In the **Scale** text field, type $1e-7$.
- 9 In the **Model Builder** window, under **Study 1: Normal Operation** > **Solver Configurations** > **Solution 1 (sol1)** > **Dependent Variables 1** click **Electric Potential (Material) (comp1.es.depV)**.
- 10 In the **Settings** window for **Field**, locate the **Scaling** section.
- 11 From the **Method** list, choose **Manual**.
- 12 In the **Scale** text field, type $1e-3$.
- 13 In the **Model Builder** window, under **Study 1: Normal Operation** > **Solver Configurations** > **Solution 1 (sol1)** > **Dependent Variables 1** click **Floating Potential (comp1.es.fp1.V0_ode)**.
- 14 In the **Settings** window for **State**, locate the **Scaling** section.
- 15 From the **Method** list, choose **Manual**.
- 16 In the **Scale** text field, type $5e-5$.
- 17 In the **Model Builder** window, expand the **Study 1: Normal Operation** > **Solver Configurations** > **Solution 1 (sol1)** > **Stationary Solver 1** > **Segregated 1** node.
- 18 Right-click **Study 1: Normal Operation** > **Solver Configurations** > **Solution 1 (sol1)** > **Stationary Solver 1** > **Segregated 1** > **Electric Potential** and choose **Move Down**.
- 19 Right-click **Study 1: Normal Operation** > **Solver Configurations** > **Solution 1 (sol1)** > **Stationary Solver 1** > **Segregated 1** > **Electric Potential** and choose **Move Down**.
Because of the **Floating Potential** features used in the model, use the direct solver for the segregated groups.
- 20 In the **Model Builder** window, under **Study 1: Normal Operation** > **Solver Configurations** > **Solution 1 (sol1)** > **Stationary Solver 1** > **Segregated 1** click **Displacement Field**.
- 21 In the **Settings** window for **Segregated Step**, locate the **General** section.
- 22 From the **Linear solver** list, choose **Direct**.
- 23 In the **Model Builder** window, under **Study 1: Normal Operation** > **Solver Configurations** > **Solution 1 (sol1)** > **Stationary Solver 1** > **Segregated 1** click **Spatial Mesh Displacement**.
- 24 In the **Settings** window for **Segregated Step**, locate the **General** section.
- 25 From the **Linear solver** list, choose **Direct**.
- 26 In the **Model Builder** window, under **Study 1: Normal Operation** > **Solver Configurations** > **Solution 1 (sol1)** > **Stationary Solver 1** > **Segregated 1** click **Electric Potential**.
- 27 In the **Settings** window for **Segregated Step**, locate the **General** section.
- 28 From the **Linear solver** list, choose **Direct**.

29 In the **Study** toolbar, click  **Compute**.

RESULTS

Volume 1

- 1 In the **Model Builder** window, expand the **Displacement (solid)** node, then click **Volume 1**.
- 2 In the **Settings** window for **Volume**, locate the **Expression** section.
- 3 In the **Expression** text field, type `u`.
- 4 In the **Displacement (solid)** toolbar, click  **Plot**.

Multislice 1

- 1 In the **Model Builder** window, expand the **Electric Potential (es)** node, then click **Multislice 1**.
- 2 In the **Settings** window for **Multislice**, locate the **Expression** section.
- 3 From the **Unit** list, choose **mV**.
- 4 Locate the **Multipane Data** section. Find the **x-planes** subsection. From the **Entry method** list, choose **Number of planes**.
- 5 In the **Planes** text field, type `0`.
- 6 Find the **y-planes** subsection. From the **Entry method** list, choose **Number of planes**.
- 7 In the **Planes** text field, type `0`.

Streamline Multislice 1

- 1 In the **Model Builder** window, click **Streamline Multislice 1**.
- 2 In the **Settings** window for **Streamline Multislice**, locate the **Multipane Data** section.
- 3 Find the **x-planes** subsection. From the **Entry method** list, choose **Number of planes**.
- 4 In the **Planes** text field, type `0`.
- 5 Find the **y-planes** subsection. From the **Entry method** list, choose **Number of planes**.
- 6 In the **Planes** text field, type `0`.
- 7 In the **Electric Potential (es)** toolbar, click  **Plot**.

ID Plot Group 5

In the **Results** toolbar, click  **ID Plot Group**.

Point Graph 1

- 1 Right-click **ID Plot Group 5** and choose **Point Graph**.
- 2 Select Point 65 only.
- 3 In the **Settings** window for **Point Graph**, locate the **y-Axis Data** section.

4 In the **Expression** text field, type u.

Displacement vs. Acceleration

- 1 In the **Model Builder** window, under **Results** click **ID Plot Group 5**.
- 2 In the **Settings** window for **ID Plot Group**, type Displacement vs. Acceleration in the **Label** text field.
- 3 Locate the **Plot Settings** section.
- 4 Select the **x-axis label** checkbox. In the associated text field, type Acceleration (g).
- 5 In the **Displacement vs. Acceleration** toolbar, click  **Plot**.

ID Plot Group 6

In the **Results** toolbar, click  **ID Plot Group**.

Global 1

- 1 Right-click **ID Plot Group 6** and choose **Global**.
- 2 In the **Settings** window for **Global**, locate the **y-Axis Data** section.
- 3 In the table, enter the following settings:



Expression	Unit	Description
es.fp1.V0*1000	mV	Raw sense voltage

- 4 Click to expand the **Legends** section. Clear the **Show legends** checkbox.
- 5 In the **ID Plot Group 6** toolbar, click  **Plot**.

Sense V vs. Acceleration

- 1 In the **Model Builder** window, right-click **ID Plot Group 6** and choose **Rename**.
- 2 In the **Rename ID Plot Group** dialog, type Sense V vs. Acceleration in the **New label** text field.
- 3 Click **OK**.

ADD STUDY

- 1 In the **Home** toolbar, click  **Add Study** to open the **Add Study** window.
- 2 Go to the **Add Study** window.
- 3 Find the **Studies** subsection. In the **Select Study** tree, select **General Studies > Stationary**.
- 4 Right-click and choose **Add Study**.
- 5 In the **Home** toolbar, click  **Add Study** to close the **Add Study** window.

STUDY 2

Step 1: Stationary

- 1 In the **Settings** window for **Stationary**, locate the **Study Extensions** section.
- 2 Select the **Auxiliary sweep** checkbox.
- 3 Click  **Add**.
- 4 In the table, enter the following settings:

Parameter name	Parameter value list	Parameter unit
VtestL (Test voltage, left side)	2 0	V

- 5 Click  **Add**.
- 6 In the table, enter the following settings:

Parameter name	Parameter value list	Parameter unit
VtestR (Test voltage, right side)	0 2	V

- 7 From the **Run continuation for list**, choose **No parameter**.
- 8 In the **Model Builder** window, click **Study 2**.
- 9 In the **Settings** window for **Study**, type Study 2: Self Test in the **Label** text field.



Solution 2 (sol2)

- 1 In the **Study** toolbar, click  **Show Default Solver**.
- 2 In the **Model Builder** window, expand the **Solution 2 (sol2)** node.
- 3 In the **Model Builder** window, expand the **Study 2: Self Test > Solver Configurations > Solution 2 (sol2) > Dependent Variables 1** node, then click **Spatial Mesh Displacement (comp1.spatial.disp)**.
- 4 In the **Settings** window for **Field**, locate the **Scaling** section.
- 5 In the **Scale** text field, type $1e-8$.
- 6 In the **Model Builder** window, under **Study 2: Self Test > Solver Configurations > Solution 2 (sol2) > Dependent Variables 1** click **Displacement Field (comp1.u)**.
- 7 In the **Settings** window for **Field**, locate the **Scaling** section.
- 8 In the **Scale** text field, type $1e-8$.
- 9 In the **Model Builder** window, under **Study 2: Self Test > Solver Configurations > Solution 2 (sol2) > Dependent Variables 1** click **Electric Potential (Material) (comp1.es.depV)**.
- 10 In the **Settings** window for **Field**, locate the **Scaling** section.

- 11 From the **Method** list, choose **Manual**.
- 12 In the **Scale** text field, type 1.
- 13 In the **Model Builder** window, under **Study 2: Self Test > Solver Configurations > Solution 2 (sol2) > Dependent Variables 1** click **Floating Potential (comp1.es.fp1.V0_ode)**.
- 14 In the **Settings** window for **State**, locate the **Scaling** section.
- 15 From the **Method** list, choose **Manual**.
- 16 In the **Scale** text field, type 0.1.
Because of the **Floating Potential** features used in the model, use the direct solver for the segregated groups.
- 17 In the **Model Builder** window, expand the **Study 2: Self Test > Solver Configurations > Solution 2 (sol2) > Stationary Solver 1 > Segregated 1** node, then click **Electric Potential**.
- 18 In the **Settings** window for **Segregated Step**, locate the **General** section.
- 19 From the **Linear solver** list, choose **Direct**.
- 20 In the **Model Builder** window, under **Study 2: Self Test > Solver Configurations > Solution 2 (sol2) > Stationary Solver 1 > Segregated 1** click **Displacement Field**.
- 21 In the **Settings** window for **Segregated Step**, locate the **General** section.
- 22 From the **Linear solver** list, choose **Direct**.
- 23 In the **Model Builder** window, under **Study 2: Self Test > Solver Configurations > Solution 2 (sol2) > Stationary Solver 1 > Segregated 1** click **Spatial Mesh Displacement**.
- 24 In the **Settings** window for **Segregated Step**, locate the **General** section.
- 25 From the **Linear solver** list, choose **Direct**.
- 26 In the **Study** toolbar, click  **Compute**.

RESULTS

Volume 1

- 1 In the **Model Builder** window, expand the **Displacement (solid) 1** node, then click **Volume 1**.
- 2 In the **Settings** window for **Volume**, locate the **Expression** section.
- 3 In the **Expression** text field, type u.
- 4 In the **Displacement (solid) 1** toolbar, click  **Plot**.
- 5 Click the  **Zoom Extents** button in the **Graphics** toolbar.

Multislice I

- 1 In the **Model Builder** window, expand the **Electric Potential (es) I** node, then click **Multislice I**.
- 2 In the **Settings** window for **Multislice**, locate the **Multiplane Data** section.
- 3 Find the **x-planes** subsection. From the **Entry method** list, choose **Number of planes**.
- 4 In the **Planes** text field, type 0.
- 5 Find the **y-planes** subsection. From the **Entry method** list, choose **Number of planes**.
- 6 In the **Planes** text field, type 0.

Streamline Multislice I

- 1 In the **Model Builder** window, click **Streamline Multislice I**.
- 2 In the **Settings** window for **Streamline Multislice**, locate the **Multiplane Data** section.
- 3 Find the **x-planes** subsection. From the **Entry method** list, choose **Number of planes**.
- 4 In the **Planes** text field, type 0.
- 5 Find the **y-planes** subsection. From the **Entry method** list, choose **Number of planes**.
- 6 In the **Planes** text field, type 0.
- 7 In the **Electric Potential (es) I** toolbar, click  **Plot**.

ID Plot Group II

- 1 In the **Results** toolbar, click  **ID Plot Group**.
- 2 In the **Settings** window for **ID Plot Group**, locate the **Data** section.
- 3 From the **Dataset** list, choose **Study 2: Self Test/Solution 2 (sol2)**.

Point Graph I

- 1 Right-click **ID Plot Group II** and choose **Point Graph**.
- 2 Select Point 65 only.
- 3 In the **Settings** window for **Point Graph**, locate the **y-Axis Data** section.
- 4 In the **Expression** text field, type u.
- 5 Locate the **x-Axis Data** section. From the **Parameter** list, choose **Expression**.
- 6 In the **Expression** text field, type V_{testR} .
- 7 In the **ID Plot Group II** toolbar, click  **Plot**.

Displacement vs. Self Test V

- 1 In the **Model Builder** window, right-click **ID Plot Group II** and choose **Rename**.
- 2 In the **Rename ID Plot Group** dialog, type Displacement vs. Self Test V in the **New label** text field.

3 Click **OK**.



Appendix — Geometry Instructions

From the **File** menu, choose **New**.

NEW

In the **New** window, click  **Model Wizard**.

MODEL WIZARD

- 1 In the **Model Wizard** window, click  **3D**.
- 2 In the **Select Physics** tree, select **Structural Mechanics > Electromagnetics–Structure Interaction > Electromechanics > Electromechanics, Solid**.
- 3 Click **Add**.
- 4 Click  **Study**.
- 5 In the **Select Study** tree, select **General Studies > Stationary**.
- 6 Click  **Done**.

GEOMETRY I

- 1 In the **Geometry** toolbar, click **Load Part** and choose **Load Part**.
- 2 Browse to the model's Application Libraries folder and double-click the file `surface_micromachined_accelerometer_geom_subsequence.mph`.
- 3 In the **Load Part** dialog, in the **Select parts** list, choose **Proof mass with fingers, Spring and anchor**, and **Electrode array**.
- 4 Click **OK**.

GLOBAL DEFINITIONS

Parameters I



- 1 In the **Model Builder** window, under **Global Definitions** click **Parameters I**.
- 2 In the **Settings** window for **Parameters**, locate the **Parameters** section.
- 3 Click  **Load from File**.
- 4 Browse to the model's Application Libraries folder and double-click the file `surface_micromachined_accelerometer_parameters.txt`.

GEOMETRY I

Part Link: Proof mass

- 1 In the **Geometry** toolbar, click  **Part Instance** and choose **Proof mass with fingers**.
- 2 In the **Settings** window for **Part Instance**, type Part Link: Proof mass in the **Label** text field.
- 3 Locate the **Input Parameters** section. In the table, enter the following settings:

Name	Expression	Value	Description
l_PM	l_PM	4.48E-4 m	Proof mass length
w_PM	w_PM	1E-4 m	Proof mass full width
t_PM	tSi	2E-6 m	Proof mass thickness
l_f	l_f	1.14E-4 m	Length of finger
w_f	w_f	4E-6 m	Width of finger
n_st	n_st	3	Number of self test fingers
n_f	n_f	21	Number of sense fingers
g_f	g_f	1E-6 m	Gap between sense fingers
g_st	g_st	3E-6 m	Gap between self test fingers
x_st	x_st	1E-5 m	Starting position of self test fingers
x_f	x_f	7.2E-5 m	Starting position of sense fingers
w_eh	w_eh	4E-6 m	Etch hole size
p_eh	p_eh	1.8E-5 m	Etch hole period

- 4 Click  **Build All Objects**.
- 5 Click the  **Zoom Extents** button in the **Graphics** toolbar.

Part Link: Spring 1

- 1 In the **Geometry** toolbar, click  **Part Instance** and choose **Spring and anchor**.
- 2 In the **Settings** window for **Part Instance**, type Part Link: Spring 1 in the **Label** text field.
- 3 Locate the **Input Parameters** section. In the table, enter the following settings:

Name	Expression	Value	Description
l_sp	l_sp	2.8E-4 m	Spring length
w_sp	w_sp	2E-6 m	Spring width
g_sp	g_sp	1E-6 m	Spring gap

Name	Expression	Value	Description
w_sp_conn	w_sp_conn	4E-6 m	Spring connection width
w_f	w_f	4E-6 m	Guard finger width
l_anch_base	l_anch_base	1.7E-5 m	Anchor base length
w_anch_base	w_anch_base	1.7E-5 m	Anchor base width
r_anch	r_anch	3E-6 m	Anchor radius
x_anch	x_anch	1.2E-5 m	Anchor position
t_sp	tSi	2E-6 m	Spring thickness
t_anch	t0x	1.6E-6 m	Anchor thickness
x_sp	l_PM	4.48E-4 m	Position

4 Click  **Build All Objects**.

Part Link: Spring 2

- 1 Right-click **Part Link: Spring 1** and choose **Duplicate**.
- 2 In the **Settings** window for **Part Instance**, type Part Link: Spring 2 in the **Label** text field.
- 3 Locate the **Input Parameters** section. In the table, enter the following settings:

Name	Expression	Value	Description
mirror	0	0	0: no mirror. 1: mirror
l_sp	l_sp+10[um]	2.9E-4 m	Spring length
w_anch_base	w_anch_base+10[um]	2.7E-5 m	Anchor base width
x_sp	0[um]	0 m	Position

4 Click  **Build All Objects**.

Part Link: Sense Electrodes L

- 1 In the **Geometry** toolbar, click  **Part Instance** and choose **Electrode array**.
- 2 In the **Settings** window for **Part Instance**, locate the **Input Parameters** section.
- 3 In the table, enter the following settings:

Name	Expression	Value	Description
LH	0	0	0: RH, 1: LH
l_e	l_e_l	1.4E-4 m	Electrode length
w_e	w_f	4E-6 m	Electrode width
l_p	l_p	1.6E-5 m	Pad length

Name	Expression	Value	Description
w_p	w_p	8E-6 m	Pad width
r_an	r_an	3E-6 m	Anchor radius
t_e	tSi	2E-6 m	Electrode thickness
t_an	t0x	1.6E-6 m	Anchor thickness
n_e	n_f+1	22	Number of electrodes
p_e	3*(w_f+g_f)	1.5E-5 m	Periodicity
x_e	x_f-w_f-g_f	6.7E-5 m	x position
y_e	w_PM/2+1_f-1_ovr1p	6E-5 m	y position

4 In the **Label** text field, type Part Link: Sense Electrodes L.

5 Click  **Build All Objects**.

6 Click the  **Wireframe Rendering** button in the **Graphics** toolbar.

Part Link: Sense Electrodes R

1 Right-click **Part Link: Sense Electrodes L** and choose **Duplicate**.

2 In the **Settings** window for **Part Instance**, type Part Link: Sense Electrodes R in the **Label** text field.

3 Locate the **Input Parameters** section. In the table, enter the following settings:

Name	Expression	Value	Description
LH	1	1	0: RH, 1: LH
l_e	l_e_s	1.2E-4 m	Electrode length
x_e	x_f-2*(w_f+g_f)	6.2E-5 m	x position

4 Click  **Build All Objects**.

Part Link: Self Test Electrodes L 1

1 Right-click **Part Link: Sense Electrodes R** and choose **Duplicate**.

2 In the **Settings** window for **Part Instance**, type Part Link: Self Test Electrodes L 1 in the **Label** text field.

3 Locate the **Input Parameters** section. In the table, enter the following settings:

Name	Expression	Value	Description
LH	0	0	0: RH, 1: LH
n_e	n_st	3	Number of electrodes

Name	Expression	Value	Description
p_e	$3*w_f+2*g_f+g_{st}$	1.7E-5 m	Periodicity
x_e	$x_f-2*(w_f+g_f)$	6.2E-5 m	x position

4 Click  **Build All Objects.**

5 In the table, enter the following settings:

Name	Expression	Value	Description
x_e	$x_{st}-w_f-g_f$	5E-6 m	x position

6 Click  **Build All Objects.**

Part Link: Self Test Electrodes L 2

1 Right-click **Part Link: Self Test Electrodes L 1** and choose **Duplicate.**

2 In the **Settings** window for **Part Instance**, type Part Link: Self Test Electrodes L 2 in the **Label** text field.

3 Locate the **Input Parameters** section. In the table, enter the following settings:

Name	Expression	Value	Description
l_e	l_{e1}	1.4E-4 m	Electrode length
x_e	$l_{PM}-(x_{st}+w_f+g_f)-(n_{st}-1)*(3*w_f+2*g_f+g_{st})-w_f$	3.95E-4 m	x position

4 Click  **Build All Objects.**

Part Link: Self Test Electrodes R 1

1 Right-click **Part Link: Self Test Electrodes L 2** and choose **Duplicate.**

2 In the **Settings** window for **Part Instance**, type Part Link: Self Test Electrodes R 1 in the **Label** text field.

3 Locate the **Input Parameters** section. In the table, enter the following settings:

Name	Expression	Value	Description
LH	1	1	0: RH, 1: LH
x_e	$x_{st}-w_f-g_f+2*(w_f+g_f)$	1.5E-5 m	x position

4 Click  **Build All Objects.**

Part Link: Self Test Electrodes R 2

1 Right-click **Part Link: Self Test Electrodes R 1** and choose **Duplicate.**

2 In the **Settings** window for **Part Instance**, type Part Link: Self Test Electrodes R 2 in the **Label** text field.

3 Locate the **Input Parameters** section. In the table, enter the following settings:

Name	Expression	Value	Description
l_e	l_e_s	1.2E-4 m	Electrode length
x_e	$l_{PM} - (x_{st} + w_f + g_f) - (n_{st} - 1) * (3 * w_f + 2 * g_f + g_{st}) - w_f + 2 * (w_f + g_f)$	4.05E-4 m	x position

4 Click  **Build All Objects**.

5 Click the  **Go to Default View** button in the **Graphics** toolbar.

Air box

1 In the **Geometry** toolbar, click  **Block**.

2 In the **Settings** window for **Block**, type Air box in the **Label** text field.

3 Locate the **Size and Shape** section. In the **Width** text field, type $1_polySi + 40[um]$.

4 In the **Depth** text field, type $hw_polySi + 20[um]$.

5 In the **Height** text field, type $10[um]$.

6 Locate the **Position** section. In the **x** text field, type $-1_spAssm - 20[um]$.

7 In the **z** text field, type $-t0x$.

8 Click to expand the **Layers** section. In the table, enter the following settings:

Layer name	Thickness (m)
Layer 1	t0x
Layer 2	tSi

9 Click  **Build All Objects**.

10 In the **Model Builder** window, click **Geometry 1**.

11 In the **Settings** window for **Geometry**, locate the **Units** section.

12 From the **Length unit** list, choose μm .

13 In the **Model Builder** window, click **Air box (blk1)**.

14 In the **Settings** window for **Block**, click  **Build All Objects**.

15 Click the  **Go to Default View** button in the **Graphics** toolbar.



Ground plane

- 1 In the **Geometry** toolbar, click  **Work Plane**.
- 2 In the **Settings** window for **Work Plane**, type Ground plane in the **Label** text field.
- 3 Locate the **Plane Definition** section. In the **z-coordinate** text field, type -t0x.

Ground plane (wp1) > Plane Geometry

- 1 In the **Model Builder** window, click **Plane Geometry**.
- 2 Click the  **Zoom Extents** button in the **Graphics** toolbar.

Ground plane (wp1) > Rectangle 1 (r1)

- 1 In the **Work Plane** toolbar, click  **Rectangle**.
- 2 In the **Settings** window for **Rectangle**, locate the **Size and Shape** section.
- 3 In the **Width** text field, type 1_PM.
- 4 In the **Height** text field, type w_PM/2+1_f.
- 5 Click  **Build Selected**.

Extrude 1 (ext1)

- 1 In the **Model Builder** window, right-click **Geometry 1** and choose **Extrude**.
- 2 In the **Settings** window for **Extrude**, locate the **Distances** section.
- 3 In the table, enter the following settings:

Distances (μm)
t0x

- 4 Click  **Build Selected**.

Part Link: Proof mass (pi1)

- 1 In the **Model Builder** window, click **Part Link: Proof mass (pi1)**.
- 2 In the **Settings** window for **Part Instance**, click to expand the **Domain Selections** section.
- 3 Click to select the first row in the table.
- 4 Click **New Cumulative Selection**.
- 5 In the **New Cumulative Selection** dialog, type Polysilicon in the **Name** text field.
- 6 Click **OK**.
- 7 In the **Settings** window for **Part Instance**, click to expand the **Boundary Selections** section.
- 8 Click **New Cumulative Selection**.
- 9 In the **New Cumulative Selection** dialog, type Proof mass boundaries in the **Name** text field.

10 Click **OK**.

11 In the **Settings** window for **Part Instance**, locate the **Boundary Selections** section.

12 In the table, enter the following settings:

Name	Keep	Physics	Contribute to
Proof Mass + Fingers Seq		√	Proof mass boundaries

Part Link: Spring 1 (pi2)

1 In the **Model Builder** window, click **Part Link: Spring 1 (pi2)**.

2 In the **Settings** window for **Part Instance**, locate the **Domain Selections** section.

3 In the table, enter the following settings:

Name	Keep	Physics	Contribute to
Spring + anchor		√	Polysilicon

4 Locate the **Boundary Selections** section. In the table, enter the following settings:

Name	Keep	Physics	Contribute to
Spring + anchor		√	Proof mass boundaries

Part Link: Spring 2 (pi3)

1 In the **Model Builder** window, click **Part Link: Spring 2 (pi3)**.

2 In the **Settings** window for **Part Instance**, locate the **Domain Selections** section.

3 In the table, enter the following settings:

Name	Keep	Physics	Contribute to
Spring + anchor		√	Polysilicon

4 Locate the **Boundary Selections** section. In the table, enter the following settings:

Name	Keep	Physics	Contribute to
Spring + anchor		√	Proof mass boundaries

Part Link: Sense Electrodes L (pi4)

1 In the **Model Builder** window, click **Part Link: Sense Electrodes L (pi4)**.

2 In the **Settings** window for **Part Instance**, locate the **Domain Selections** section.

3 In the table, enter the following settings:

Name	Keep	Physics	Contribute to
Electrode array		√	Polysilicon

4 Locate the **Boundary Selections** section. Click to select the first row in the table.

5 Click **New Cumulative Selection**.

6 In the **New Cumulative Selection** dialog, type *Sense left boundaries* in the **Name** text field.

7 Click **OK**.

Part Link: Sense Electrodes R (pi5)

1 In the **Model Builder** window, click **Part Link: Sense Electrodes R (pi5)**.

2 In the **Settings** window for **Part Instance**, locate the **Domain Selections** section.

3 In the table, enter the following settings:

Name	Keep	Physics	Contribute to
Electrode array		√	Polysilicon

4 Locate the **Boundary Selections** section. Click to select the first row in the table.

5 Click **New Cumulative Selection**.

6 In the **New Cumulative Selection** dialog, type *Sense right boundaries* in the **Name** text field.

7 Click **OK**.

Part Link: Self Test Electrodes L I (pi6)

1 In the **Model Builder** window, click **Part Link: Self Test Electrodes L I (pi6)**.

2 In the **Settings** window for **Part Instance**, locate the **Domain Selections** section.

3 In the table, enter the following settings:

Name	Keep	Physics	Contribute to
Electrode array		√	Polysilicon

4 Locate the **Boundary Selections** section. Click **New Cumulative Selection**.

5 In the **New Cumulative Selection** dialog, type *Self test left boundaries* in the **Name** text field.

6 Click **OK**.

7 In the **Settings** window for **Part Instance**, locate the **Boundary Selections** section.

8 In the table, enter the following settings:

Name	Keep	Physics	Contribute to
Electrode array		√	Self test left boundaries

Part Link: Self Test Electrodes L 2 (pi7)

1 In the **Model Builder** window, expand the **Component 1 (comp1) > Geometry 1 > Cumulative Selections** node, then click **Component 1 (comp1) > Geometry 1 > Part Link: Self Test Electrodes L 2 (pi7)**.

2 In the **Settings** window for **Part Instance**, locate the **Domain Selections** section.

3 In the table, enter the following settings:

Name	Keep	Physics	Contribute to
Electrode array		√	Polysilicon

4 Locate the **Boundary Selections** section. In the table, enter the following settings:

Name	Keep	Physics	Contribute to
Electrode array		√	Self test left boundaries

Part Link: Self Test Electrodes R 1 (pi8)

1 In the **Model Builder** window, click **Part Link: Self Test Electrodes R 1 (pi8)**.

2 In the **Settings** window for **Part Instance**, locate the **Domain Selections** section.

3 In the table, enter the following settings:

Name	Keep	Physics	Contribute to
Electrode array		√	Polysilicon

4 Click to select the first row in the table.

5 Locate the **Boundary Selections** section. Click **New Cumulative Selection**.

6 In the **New Cumulative Selection** dialog, type Self test right boundaries in the **Name** text field.

7 Click **OK**.

8 In the **Settings** window for **Part Instance**, locate the **Boundary Selections** section.

9 In the table, enter the following settings:

Name	Keep	Physics	Contribute to
Electrode array		√	Self test right boundaries

Part Link: Self Test Electrodes R 2 (pi9)

- 1 In the **Model Builder** window, click **Part Link: Self Test Electrodes R 2 (pi9)**.
- 2 In the **Settings** window for **Part Instance**, locate the **Domain Selections** section.
- 3 In the table, enter the following settings:

Name	Keep	Physics	Contribute to
Electrode array		√	Polysilicon

- 4 Locate the **Boundary Selections** section. In the table, enter the following settings:

Name	Keep	Physics	Contribute to
Electrode array		√	Self test right boundaries

Ground plane (wp1)

In the **Model Builder** window, collapse the **Component 1 (comp1) > Geometry 1 > Ground plane (wp1)** node.

Cumulative Selections

- 1 In the **Model Builder** window, collapse the **Component 1 (comp1) > Geometry 1 > Cumulative Selections** node.
- 2 In the **Model Builder** window, collapse the **Geometry 1** node.

DEFINITIONS

Symmetry plane

- 1 In the **Definitions** toolbar, click  **Box**.
- 2 In the **Settings** window for **Box**, locate the **Geometric Entity Level** section.
- 3 From the **Level** list, choose **Boundary**.
- 4 Locate the **Box Limits** section. In the **y minimum** text field, type -0.1.
- 5 In the **y maximum** text field, type 0.1.
- 6 Locate the **Output Entities** section. From the **Include entity if** list, choose **Entity inside box**.
- 7 In the **Label** text field, type Symmetry plane.

Anchor plane

- 1 In the **Definitions** toolbar, click  **Box**.
- 2 In the **Settings** window for **Box**, type Anchor plane in the **Label** text field.
- 3 Locate the **Geometric Entity Level** section. From the **Level** list, choose **Boundary**.

- 4 Locate the **Box Limits** section. In the **z minimum** text field, type $-t0x*1.01$.
- 5 In the **z maximum** text field, type $-t0x*0.99$.
- 6 Locate the **Output Entities** section. From the **Include entity if** list, choose **Entity inside box**.

Meshing plane

- 1 In the **Definitions** toolbar, click  **Box**.
- 2 In the **Settings** window for **Box**, type *Meshing plane* in the **Label** text field.
- 3 Locate the **Geometric Entity Level** section. From the **Level** list, choose **Boundary**.
- 4 Locate the **Box Limits** section. In the **z minimum** text field, type $-t0x*0.01$.
- 5 In the **z maximum** text field, type $t0x*0.01$.
- 6 Locate the **Output Entities** section. From the **Include entity if** list, choose **Entity inside box**.