



Model created in COMSOL Multiphysics 6.4

# Squeeze-Film Gas Damping in an Accelerometer

Micromechanical structures that use capacitance to measure another parameter such as acceleration typically have a very narrow gap between their electrodes. The gap usually contains gas, which damps the movements of the mechanical parts. This model of a microsystem accelerometer shows how to couple squeeze-film gas damping, which you model with the nonlinear Reynolds equation, to displacements in the sensor.

## *Introduction*

---

Squeeze-film gas damping is a critical aspect of many MEMS transducers and actuators. An example of a microsystem component where gas-damping properties are important is an accelerometer common in vehicle motion-control and safety systems.

In accelerometers, inertia produces a motion that the device detects. A typical structure connects a large proof mass, with dimensions typically in millimeters, to surrounding structures with elastic beams. This combination forms a mechanical oscillator with a specific resonance frequency. However, in accurate motion-detection applications these resonances are unwanted, and the device damps the movements to produce smooth time-step and frequency responses. Such a device can usually achieve suitable damping with a low gas pressure (100 Pa–1000 Pa) that, considering the dimensions of the device, leads to rarefied gas effect in the system.

A narrow gap formed by two solid horizontal plates restricts the displacement of the gas perpendicular to the surfaces. When the sensor squeezes the gap, the gas flows out from its edges. The narrow pathway restricts the flow, which causes gas pressure to increase. This increase in gas pressure, in turn, decelerates the plates' movement.

You can model the pressure distribution in the narrow gap with the *modified Reynolds equation*

$$\frac{d}{dt}(ph) + \nabla_t \cdot (ph\mathbf{u}) - p((\nabla_t h_s \cdot \mathbf{u}_s) - (\nabla_t h_b \cdot \mathbf{u}_b)) = 0$$

where the total fluid pressure  $p$  is the sum of the initial/ambient pressure,  $p_A$  and the variation  $p_f$ ;  $h = h_0 + \Delta h(t)$  is the gap height consisting of the initial gap and the deformation in the normal direction of the boundary;  $h_s$  is the location of the solid wall;  $h_b$  is the location of the channel base; and  $\mathbf{u}_s$  and  $\mathbf{u}_b$  define the tangential velocity of the solid wall and the channel base, respectively. Furthermore, the mean film velocity  $\mathbf{u}$  is given by

$$\mathbf{u} = \frac{-\nabla_t p}{12\eta} h^2 Q_{ch} + \frac{(\mathbf{u}_s + \mathbf{u}_b)}{2}$$

where  $\eta$  denotes the fluid viscosity at normal conditions and the term  $Q_{\text{ch}}$  is the relative flow rate function that accounts for the rarefied gas effects. Veijola and others (Ref. 2) have used a simple equation for the relative flow coefficient

$$Q_{\text{ch}} = 1 + 9.638(\sigma_P K_n)^{1.159}$$

which is valid for  $0 \leq K_n \leq 880$ . The Knudsen number is the ratio between the gas' mean free path,  $\lambda$ , and the gap height,  $h$ :

$$K_n = \frac{\lambda}{h}$$

The coefficient  $\sigma_P$  is calculated from the tangential momentum accommodation coefficient,  $\alpha_v$ :

$$\sigma_P = \frac{2 - \alpha_v}{\alpha_v} (1.016 - 0.1211(1 - \alpha_v))$$

The mean free path at a pressure  $p$  comes from

$$\lambda = \frac{p_0}{p} \lambda_0$$

where  $\lambda_0$  is the mean free path at the reference pressure  $p_0$ .

Another way to tune the damping is to perforate the structure with holes. By adding a term related to the gas flow through the holes, it is also possible to use the Reynolds equation for perforated plates. For more information about this approach see Ref. 3.

### *Model Definition*

---

This example models the solid moving parts in the accelerometer using the **Solid Mechanics** interface in 3D and using the **Solid Mechanics** interface with a plane strain approximation in 2D. This model solves the squeeze-film air damping on the lower and upper surfaces using the **Structure–Thin-Film Flow Interaction** multiphysics coupling. The model constrains the film pressure,  $p_f$ , to 0 at the edges of the boundary.

The following two figures show the accelerometer geometry in 3D and in 2D. The model consists of two thin silicon cantilever beams and a silicon proof mass. The cantilever beams are fixed to the surrounding structures at one end. The proof mass reacts to inertial forces and bends the cantilevers. The external acceleration,  $a$ , acts in the  $z$  direction and causes a body volume force  $F_z = \rho_{\text{solid}} a$ .

In 2D the two cantilevers are lumped as one structure whose thickness equals the sum of the thicknesses of the two cantilevers. Consequently, the model has two domains with different thicknesses at the connecting boundary. You should therefore be prudent when inspecting stress levels near this area.

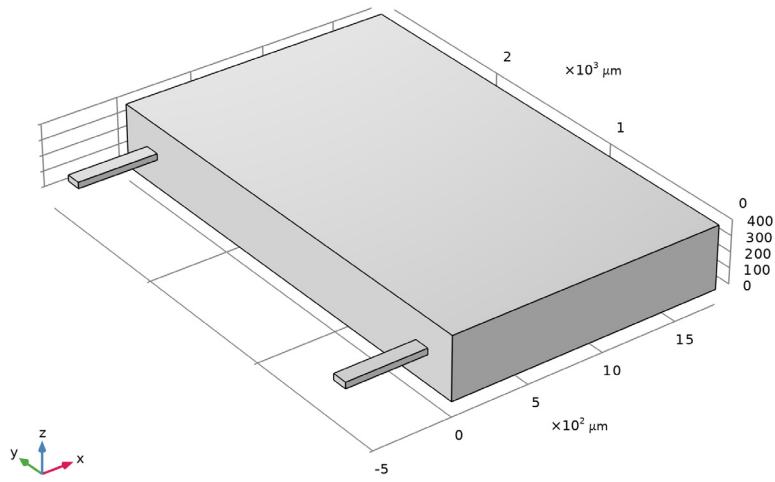

Figure 1: Model geometry in 3D.

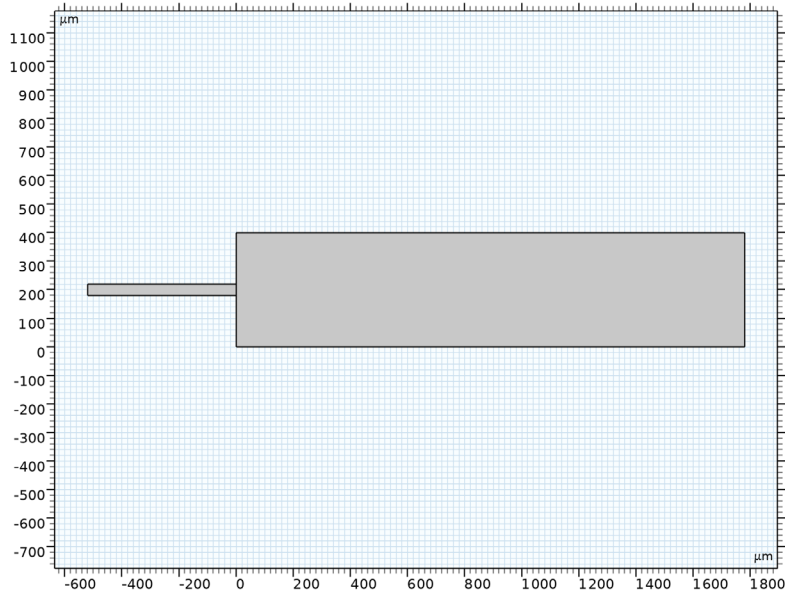

Figure 2: Model geometry in 2D.

The following tables list the structures' dimensions as well as pertinent material and gas properties used to calculate the effective viscosity:

PARAMETER	CANTILEVERS	PROOF MASS	GAP
Length	520 $\mu\text{m}$	1780 $\mu\text{m}$	1780 $\mu\text{m}$
Height	40 $\mu\text{m}$	400 $\mu\text{m}$	3.95 $\mu\text{m}$
Width	100 $\mu\text{m}$	2960 $\mu\text{m}$	2960 $\mu\text{m}$

PARAMETER	VALUE
Structure material	Silicon
Young's modulus	170 GPa
Poisson's ratio	0.28
Density	2329 $\text{kg/m}^3$
Viscosity of the gas	$22 \cdot 10^{-6} \text{Ns/m}^2$
$\lambda_0$	70 nm
$p_0$	101.325 kPa

### *Results and Discussion*

Figure 3 shows the pressure distribution on the surface of the proof mass after 4 ms of simulation. The ambient pressure,  $p_A$ , in this case is 50 Pa, and the acceleration switches on at the beginning of the simulation. The acceleration's magnitude is half that due to gravity,  $g$ . In this figure, the maximum displacement at the tip of the proof mass is roughly 0.2  $\mu\text{m}$ , or 0.05% of its thickness.

Figure 4 shows the  $z$  displacement of the proof mass tip as a function of time for ambient pressures of 50 Pa, 300 Pa, and 1000 Pa. As ambient pressure increases, the film damping at the upper and lower surfaces increases through the increase in the gas' effective viscosity and density. This increased damping results in a substantial decrease in oscillation with increasing pressure. At 300 Pa, there is no apparent oscillation, and the proof mass seems asymptotically reaching the value of 0.2  $\mu\text{m}$  in  $z$  displacement.

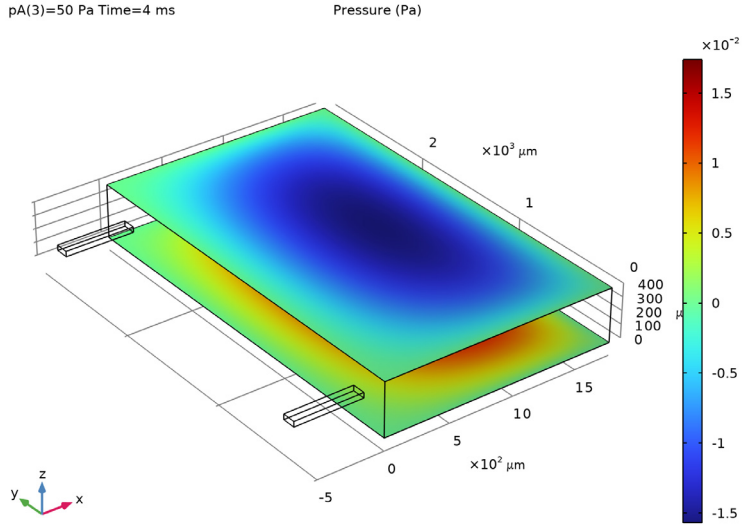

Figure 3: A load on the face of the proof mass in the z direction leads to a deformation.

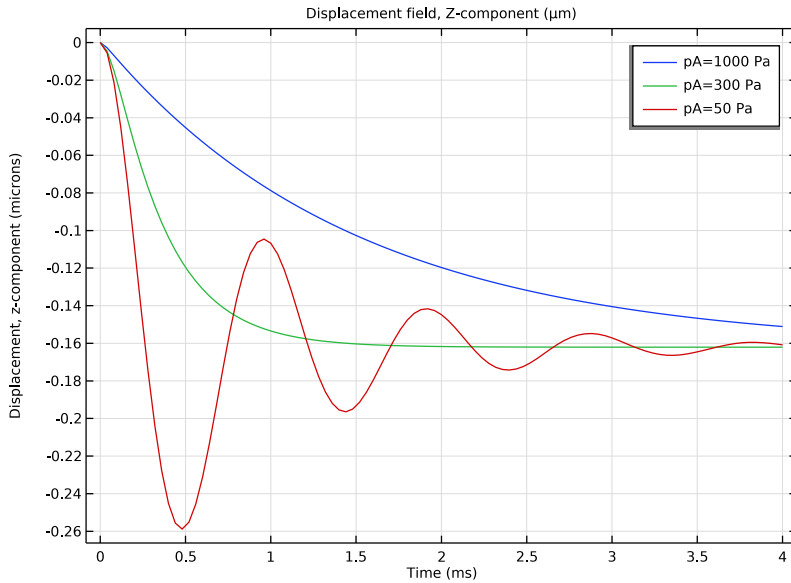

Figure 4: The z displacement of the proof mass tip at ambient pressures of 3 Pa, 30 Pa, and 300 Pa.

## References

---

1. J.B. Starr, “Squeeze-film Damping in Solid-state Accelerometers,” *Technical Digest IEEE Solid-State Sensor and Actuator Workshop*, p. 47, 1990.
2. T. Veijola, H. Kuisma, J. Lahdenperä, and T. Ryhänen, “Equivalent-circuit Model of the Squeezed Gas Film in a Silicon Accelerometer,” *Sensors and Actuators*, vol. A 48, pp. 239–248, 1995.
3. M. Bao, H. Yang, Y. Sun, and P.J. French, “Modified Reynolds’ Equation and Analytical Analysis of Squeeze-film Air Damping of Perforated Structures,” *J. Micromech. Microeng.*, vol. 13, pp. 795–800, 2003.

---

**Application Library path:** MEMS\_Module/Sensors/squeeze\_film\_accelerometer

---

## Modeling Instructions



---

From the **File** menu, choose **New**.

### NEW

In the **New** window, click  **Model Wizard**.

### MODEL WIZARD

- 1 In the **Model Wizard** window, click  **3D**.
- 2 In the **Select Physics** tree, select **Structural Mechanics** > **Fluid–Structure Interaction** > **Thin-Film Damping** > **Solid–Thin-Film Damping**.
- 3 Click **Add**.
- 4 Click  **Study**.
- 5 In the **Select Study** tree, select **General Studies** > **Time Dependent**.
- 6 Click  **Done**.

### GLOBAL DEFINITIONS

#### *Fluid Properties and Loads*

- 1 In the **Model Builder** window, under **Global Definitions** click **Parameters I**.
- 2 In the **Settings** window for **Parameters**, type Fluid Properties and Loads in the **Label** text field.

3 Locate the **Parameters** section. In the table, enter the following settings:

Name	Expression	Value	Description
a	g_const/2	4.9033 m/s <sup>2</sup>	Applied acceleration
mu	22e-6[Pa*s]	2.2E-5 Pa·s	Dynamic viscosity, fluid film
pA	300[Pa]	300 Pa	Ambient gas pressure
h0	3.95[um]	3.95E-6 m	Initial film thickness
Lambda0	70[nm]	7E-8 m	Mean free path
pref	1[atm]	1.0133E5 Pa	Reference pressure

Here, g\_const is a predefined COMSOL Multiphysics constant representing the standard acceleration of gravity.

### Geometry

- 1 In the **Home** toolbar, click  **Parameters** and choose **Add > Parameters**.
- 2 In the **Settings** window for **Parameters**, type Geometry in the **Label** text field.
- 3 Locate the **Parameters** section. In the table, enter the following settings:

Name	Expression	Value	Description
Lpm	1780[um]	0.00178 m	Length of proof mass
Hpm	400[um]	4E-4 m	Height of proof mass
Wpm	2960[um]	0.00296 m	Width of proof mass
Lc	520[um]	5.2E-4 m	Length of cantilevers
Hc	40[um]	4E-5 m	Height of cantilevers
Wc	100[um]	1E-4 m	Width of cantilevers

### GEOMETRY 1

- 1 In the **Model Builder** window, under **Component 1 (comp1)** click **Geometry 1**.
- 2 In the **Settings** window for **Geometry**, locate the **Units** section.
- 3 From the **Length unit** list, choose **µm**.

### Proof Mass



- 1 In the **Geometry** toolbar, click  **Block**.
- 2 In the **Settings** window for **Block**, type Proof Mass in the **Label** text field.
- 3 Locate the **Size and Shape** section. In the **Width** text field, type Lpm.
- 4 In the **Depth** text field, type Wpm.

5 In the **Height** text field, type  $H_{pm}$ .

#### *Cantilever 1*



- 1 In the **Geometry** toolbar, click  **Block**.
- 2 In the **Settings** window for **Block**, type Cantilever 1 in the **Label** text field.
- 3 Locate the **Size and Shape** section. In the **Width** text field, type  $L_c$ .
- 4 In the **Depth** text field, type  $W_c$ .
- 5 In the **Height** text field, type  $H_c$ .
- 6 Locate the **Position** section. In the **x** text field, type  $-L_c$ .
- 7 In the **y** text field, type  $2*W_c$ .
- 8 In the **z** text field, type  $(H_{pm} - H_c) / 2$ .

#### *Cantilever 2*

- 1 In the **Geometry** toolbar, click  **Block**.
- 2 In the **Settings** window for **Block**, type Cantilever 2 in the **Label** text field.
- 3 Locate the **Size and Shape** section. In the **Width** text field, type  $L_c$ .
- 4 In the **Depth** text field, type  $W_c$ .
- 5 In the **Height** text field, type  $H_c$ .
- 6 Locate the **Position** section. In the **x** text field, type  $-L_c$ .
- 7 In the **y** text field, type  $W_{pm} - 3*W_c$ .
- 8 In the **z** text field, type  $(H_{pm} - H_c) / 2$ .
- 9 Click  **Build All Objects**.
- 10 Click the  **Zoom Extents** button in the **Graphics** toolbar.

The geometry is now complete and should look like that in [Figure 1](#).

#### **ADD MATERIAL**

- 1 In the **Materials** toolbar, click  **Add Material** to open the **Add Material** window.
- 2 Go to the **Add Material** window.
- 3 In the tree, select **Built-in > Silicon**.
- 4 Click the **Add to Component** button in the window toolbar.
- 5 In the **Materials** toolbar, click  **Add Material** to close the **Add Material** window.

## MATERIALS

### *Silicon (mat1)*

By default, the first material you add applies on all domains so you need not alter any settings.

## SOLID MECHANICS (SOLID)

### *Body Load 1*

- 1 In the **Physics** toolbar, click  **Domains** and choose **Body Load**.
- 2 Click in the **Graphics** window and then press Ctrl+A to select all domains.
- 3 In the **Settings** window for **Body Load**, locate the **Force** section.
- 4 Specify the  $\mathbf{f}_V$  vector as

0	x
0	y
-a*solid.rho	z

### *Fixed Constraint 1*

- 1 In the **Physics** toolbar, click  **Boundaries** and choose **Fixed Constraint**.
- 2 Select Boundaries 1 and 6 only.

## THIN-FILM FLOW (TFF)

- 1 In the **Model Builder** window, under **Component 1 (comp1)** click **Thin-Film Flow (tff)**.
- 2 Select Boundaries 13 and 14 only.
- 3 In the **Settings** window for **Thin-Film Flow**, locate the **Reference Pressure** section.
- 4 In the  $p_{\text{ref}}$  text field, type pref.

### *Fluid-Film Properties 1*

- 1 In the **Model Builder** window, under **Component 1 (comp1)** > **Thin-Film Flow (tff)** click **Fluid-Film Properties 1**.
- 2 In the **Settings** window for **Fluid-Film Properties**, locate the **Model Input** section.
- 3 Click **Make All Model Inputs Editable** in the upper-right corner of the section.
- 4 In the  $p_A$  text field, type pA.
- 5 Locate the **Wall Properties** section. In the  $h_{w1}$  text field, type h0.
- 6 Locate the **Fluid Properties** section. From the  $\mu$  list, choose **User defined**. In the associated text field, type mu.

- 7 Locate the **Film Flow Model** section. From the **Film flow model** list, choose **Rarefied-total accommodation**.
- 8 From the **Mean free path** list, choose **User defined with reference pressure**.
- 9 In the  $\lambda_0$  text field, type Lambda0.

#### DEFINITIONS

Next, define nonlocal integration couplings and corresponding variables for later use in the Results section to observe the total damping force.

##### *Bottom Surface Integration Operator*

- 1 In the **Definitions** toolbar, click  **Nonlocal Couplings** and choose **Integration**.
- 2 In the **Settings** window for **Integration**, type Bottom Surface Integration Operator in the **Label** text field.
- 3 In the **Operator name** text field, type bf.
- 4 Locate the **Source Selection** section. From the **Geometric entity level** list, choose **Boundary**.
- 5 Select Boundary 13 only.

##### *Top Surface Integration Operator*

- 1 In the **Definitions** toolbar, click  **Nonlocal Couplings** and choose **Integration**.
- 2 In the **Settings** window for **Integration**, type Top Surface Integration Operator in the **Label** text field.
- 3 In the **Operator name** text field, type tf.
- 4 Locate the **Source Selection** section. From the **Geometric entity level** list, choose **Boundary**.
- 5 Select Boundary 14 only.



##### *Variables: Total Forces*

- 1 In the **Definitions** toolbar, click  **Local Variables**.
- 2 In the **Settings** window for **Variables**, type Variables: Total Forces in the **Label** text field.
- 3 Locate the **Variables** section. In the table, enter the following settings:

Name	Expression	Unit	Description
F_bottom	-bf(nz*pfilm)	N	Total force, bottom face
F_top	-tf(nz*pfilm)	N	Total force, top face

## MESH 1



### *Free Tetrahedral 1*

- 1 In the **Mesh** toolbar, click  **Free Tetrahedral**.
- 2 In the **Settings** window for **Free Tetrahedral**, click  **Build All**.  
Now, create a simplified 2D model for comparison.

## ADD COMPONENT

In the **Model Builder** window, right-click the root node and choose **Add Component > 2D**.

## ADD PHYSICS

- 1 In the **Physics** toolbar, click  **Add Physics** to open the **Add Physics** window.
- 2 Go to the **Add Physics** window.
- 3 In the tree, select **Structural Mechanics > Fluid-Structure Interaction > Thin-Film Damping > Solid-Thin-Film Damping**.
- 4 Click the **Add to Component 2** button in the window toolbar.
- 5 In the **Physics** toolbar, click  **Add Physics** to close the **Add Physics** window.



## GEOMETRY 2

- 1 In the **Settings** window for **Geometry**, locate the **Units** section.
- 2 From the **Length unit** list, choose  $\mu\text{m}$ .

### *Proof Mass*



- 1 In the **Geometry** toolbar, click  **Rectangle**.
- 2 In the **Settings** window for **Rectangle**, type Proof Mass in the **Label** text field.
- 3 Locate the **Size and Shape** section. In the **Width** text field, type Lpm.
- 4 In the **Height** text field, type Hpm.

### *Cantilevers*

- 1 In the **Geometry** toolbar, click  **Rectangle**.
- 2 In the **Settings** window for **Rectangle**, type Cantilevers in the **Label** text field.
- 3 Locate the **Size and Shape** section. In the **Width** text field, type Lc.
- 4 In the **Height** text field, type Hc.
- 5 Locate the **Position** section. In the **x** text field, type -Lc.
- 6 In the **y** text field, type (Hpm-Hc) / 2.
- 7 Click  **Build All Objects**.

8 Click the  **Zoom Extents** button in the **Graphics** toolbar.

#### ADD MATERIAL

- 1 In the **Materials** toolbar, click  **Add Material** to open the **Add Material** window.
- 2 Go to the **Add Material** window.
- 3 In the tree, select **Built-in > Silicon**.
- 4 Click the **Add to Component** button in the window toolbar.
- 5 In the **Materials** toolbar, click  **Add Material** to close the **Add Material** window.

#### SOLID MECHANICS 2 (SOLID2)

##### *Cantilevers Thickness*

- 1 In the **Physics** toolbar, click  **Domains** and choose **Change Thickness**.
- 2 In the **Settings** window for **Change Thickness**, type Cantilevers Thickness in the **Label** text field.
- 3 Select Domain 1 only.
- 4 Locate the **Change Thickness** section. In the  $d$  text field, type  $2*Wc$ .

##### *Proof Mass Thickness*

- 1 In the **Physics** toolbar, click  **Domains** and choose **Change Thickness**.
- 2 In the **Settings** window for **Change Thickness**, type Proof Mass Thickness in the **Label** text field.
- 3 Select Domain 2 only.
- 4 Locate the **Change Thickness** section. In the  $d$  text field, type  $Wpm$ .

##### *Body Load 1*

- 1 In the **Physics** toolbar, click  **Domains** and choose **Body Load**.
- 2 Click in the **Graphics** window and then press Ctrl+A to select both domains.
- 3 In the **Settings** window for **Body Load**, locate the **Force** section.
- 4 Specify the  $\mathbf{f}_V$  vector as

0	x
$-a*\text{solid2.rho}$	y

##### *Fixed Constraint 1*

- 1 In the **Physics** toolbar, click  **Boundaries** and choose **Fixed Constraint**.
- 2 Select Boundary 1 only.

## THIN-FILM FLOW 2 (TFF2)

- 1 In the **Model Builder** window, under **Component 2 (comp2)** click **Thin-Film Flow 2 (tff2)**.
- 2 Select Boundaries 5 and 8 only.
- 3 In the **Settings** window for **Thin-Film Flow**, locate the **Reference Pressure** section.
- 4 In the  $p_{\text{ref}}$  text field, type  $p_{\text{ref}}$ .

The default point setting, Border, which sets the film pressure to zero, applies to this model.

Next, define fluid-film properties on these boundaries.

### *Fluid-Film Properties 1*

- 1 In the **Model Builder** window, under **Component 2 (comp2)** > **Thin-Film Flow 2 (tff2)** click **Fluid-Film Properties 1**.
- 2 In the **Settings** window for **Fluid-Film Properties**, locate the **Model Input** section.
- 3 Click **Make All Model Inputs Editable** in the upper-right corner of the section.
- 4 In the  $p_A$  text field, type  $p_A$ .
- 5 Locate the **Wall Properties** section. In the  $h_{w1}$  text field, type  $h_0$ .
- 6 Locate the **Fluid Properties** section. From the  $\mu$  list, choose **User defined**. In the associated text field, type  $\mu$ .
- 7 Locate the **Film Flow Model** section. From the **Film flow model** list, choose **Rarefied-total accommodation**.
- 8 From the **Mean free path** list, choose **User defined with reference pressure**.
- 9 In the  $\lambda_0$  text field, type  $\lambda_0$ .

## DEFINITIONS (COMP2)

### *Bottom Surface Integration Operator*

- 1 In the **Definitions** toolbar, click  **Nonlocal Couplings** and choose **Integration**.
- 2 In the **Settings** window for **Integration**, type Bottom Surface Integration Operator in the **Label** text field.
- 3 In the **Operator name** text field, type bf2d.
- 4 Locate the **Source Selection** section. From the **Geometric entity level** list, choose **Boundary**.
- 5 Select Boundary 5 only.

### *Top Surface Integration Operator*

- 1 In the **Definitions** toolbar, click  **Nonlocal Couplings** and choose **Integration**.

- 2 In the **Settings** window for **Integration**, type Top Surface Integration Operator in the **Label** text field.
- 3 In the **Operator name** text field, type tf2d.
- 4 Locate the **Source Selection** section. From the **Geometric entity level** list, choose **Boundary**.
- 5 Select Boundary 8 only.

*Variables: Total Forces*

- 1 In the **Definitions** toolbar, click  **Local Variables**.
- 2 In the **Settings** window for **Variables**, type Variables: Total Forces in the **Label** text field.
- 3 Locate the **Variables** section. In the table, enter the following settings:

Name	Expression	Unit	Description
F_bottom2d	-bf2d(ny*pfilm2*solid2.d)	N	Total damping force, bottom face
F_top2d	-tf2d(ny*pfilm2*solid2.d)	N	Total damping force, top face

## MESH 2

*Free Quad 1*

In the **Mesh** toolbar, click  **Free Quad**.

## MULTIPHYSICS

*Structure–Thin-Film Flow Interaction 2 (stfi2)*

- 1 In the **Model Builder** window, under **Component 2 (comp2) > Multiphysics** click **Structure–Thin-Film Flow Interaction 2 (stfi2)**.
- 2 Select Boundaries 5 and 8 only.

## MESH 2

*Size*

- 1 In the **Model Builder** window, under **Component 2 (comp2) > Mesh 2** click **Size**.
- 2 In the **Settings** window for **Size**, locate the **Element Size** section.
- 3 Click the **Custom** button.
- 4 Locate the **Element Size Parameters** section. In the **Maximum element size** text field, type 85.1.

- 5 In the **Minimum element size** text field, type 0.288.
- 6 In the **Maximum element growth rate** text field, type 1.25.
- 7 In the **Curvature factor** text field, type 0.25.
- 8 In the **Resolution of narrow regions** text field, type 2.

#### STUDY I

Add a parametric sweep over the ambient pressure.

##### *Parametric Sweep*

- 1 In the **Study** toolbar, click  **Parametric Sweep**.
- 2 In the **Settings** window for **Parametric Sweep**, locate the **Study Settings** section.
- 3 Click **+ Add**.
- 4 In the table, enter the following settings:

Parameter name	Parameter value list	Parameter unit
pA (Ambient gas pressure)	1000 300 50	Pa

##### *Step 1: Time Dependent*

- 1 In the **Model Builder** window, click **Step 1: Time Dependent**.
- 2 In the **Settings** window for **Time Dependent**, locate the **Study Settings** section.
- 3 From the **Time unit** list, choose **ms**.
- 4 In the **Output times** text field, type range (0, 4e-2, 4).

If you want smoother plots you can use a time step of  $2e-5$  (20  $\mu$ s) or  $1e-5$  (10  $\mu$ s) instead. The time step 40  $\mu$ s gives reasonably smooth plots while keeping the MPH file size down.

##### *Solution 1 (sol1)*

- 1 In the **Study** toolbar, click  **Show Default Solver**.
- 2 In the **Model Builder** window, expand the **Solution 1 (sol1)** node.
- 3 In the **Model Builder** window, expand the **Study 1 > Solver Configurations > Solution 1 (sol1) > Time-Dependent Solver 1** node.
- 4 Right-click **Study 1** and choose **Compute**.

## RESULTS

### *Fluid Pressure (tff)*



- 1 In the **Fluid Pressure (tff)** toolbar, click  **Plot**.

The plot reproduces the plot in [Figure 3](#).

### *Deformation I*

- 1 In the **Model Builder** window, expand the **Fluid Pressure (tff2)** node.
- 2 Right-click **Line 1** and choose **Deformation**.
- 3 In the **Fluid Pressure (tff2)** toolbar, click  **Plot**.

## RESULT TEMPLATES

- 1 In the **Results** toolbar, click  **Result Templates** to open the **Result Templates** window.
- 2 Go to the **Result Templates** window.
- 3 In the tree, select **Study 1/Parametric Solutions 1 (4) (sol2) > Solid Mechanics 2 > Displacement (solid2)**.
- 4 Click the **Add Result Template** button in the window toolbar.
- 5 In the **Results** toolbar, click  **Result Templates** to close the **Result Templates** window.

## RESULTS

### *Displacement and Fluid Load (2D)*

In the **Settings** window for **2D Plot Group**, type **Displacement and Fluid Load (2D)** in the **Label** text field.

### *Arrow Line 1*

- 1 Right-click **Displacement and Fluid Load (2D)** and choose **Arrow Line**.
- 2 In the **Settings** window for **Arrow Line**, locate the **Expression** section.
- 3 In the **X-component** text field, type `tff2.fwallx`.
- 4 In the **Y-component** text field, type `tff2.fwall1y`.
- 5 Click to expand the **Inherit Style** section. From the **Plot** list, choose **Surface 1**.

### *Deformation I*

- 1 Right-click **Arrow Line 1** and choose **Deformation**.
- 2 In the **Displacement and Fluid Load (2D)** toolbar, click  **Plot**.

### *Displacement and Fluid Load (2D)*

Next, plot the total force on the bottom face as a function of time for the three different values of the ambient pressure.

*Total Force on Bottom Surface (3D)*

- 1 In the **Results** toolbar, click  **ID Plot Group**.
- 2 In the **Settings** window for **ID Plot Group**, type **Total Force on Bottom Surface (3D)** in the **Label** text field.
- 3 Locate the **Data** section. From the **Dataset** list, choose **Study 1/ Parametric Solutions 1 (3) (sol2)**.
- 4 Locate the **Plot Settings** section.
- 5 Select the **x-axis label** checkbox. In the associated text field, type **Time (ms)**.

*Global 1*

- 1 Right-click **Total Force on Bottom Surface (3D)** and choose **Global**.
- 2 In the **Settings** window for **Global**, locate the **y-Axis Data** section.
- 3 In the table, enter the following settings:

<b>Expression</b>	<b>Unit</b>	<b>Description</b>
F_bottom	uN	Total force, bottom face

- 4 Click to expand the **Coloring and Style** section. Click to expand the **Legends** section. Find the **Include** subsection. Clear the **Description** checkbox.

5 In the **Total Force on Bottom Surface (3D)** toolbar, click  **Plot**.

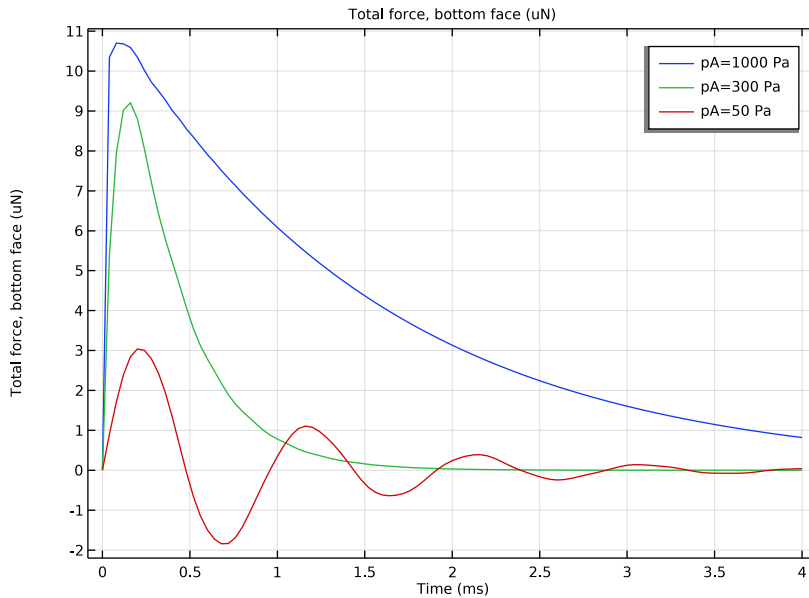

Total load on the bottom face versus time for different ambient pressure values.

NOTE: The above comment is a figure caption, show in *italic*.

Finally, plot the  $z$  displacement at the proof mass's outer and lower end. Compare the resulting plot with that in [Figure 4](#).

#### *Vertical Displacement (3D)*

- 1 In the **Results** toolbar, click  **ID Plot Group**.
- 2 In the **Settings** window for **ID Plot Group**, type **Vertical Displacement (3D)** in the **Label** text field.
- 3 Locate the **Data** section. From the **Dataset** list, choose **Study 1/ Parametric Solutions 1 (3) (sol2)**.
- 4 Locate the **Plot Settings** section.
- 5 Select the **x-axis label** checkbox. In the associated text field, type **Time (ms)**.
- 6 Select the **y-axis label** checkbox. In the associated text field, type **Displacement, z-component (microns)**.

#### *Point Graph 1*

- 1 Right-click **Vertical Displacement (3D)** and choose **Point Graph**.

2 Select Point 21 only.

This is the proof mass's bottom-right corner.

3 In the **Settings** window for **Point Graph**, click **Replace Expression** in the upper-right corner of the **y-Axis Data** section. From the menu, choose **Component 1 (comp1) > Solid Mechanics > Displacement > Displacement field - m > w - Displacement field, Z-component**.

4 Click to expand the **Legends** section. Find the **Include** subsection. Clear the **Point** checkbox.

5 Select the **Show legends** checkbox.

6 In the **Vertical Displacement (3D)** toolbar, click  **Plot**.

*Displacement and Fluid Load (2D)*

1 Click the  **Zoom Extents** button in the **Graphics** toolbar.

2 In the **Model Builder** window, under **Results** click **Displacement and Fluid Load (2D)**.

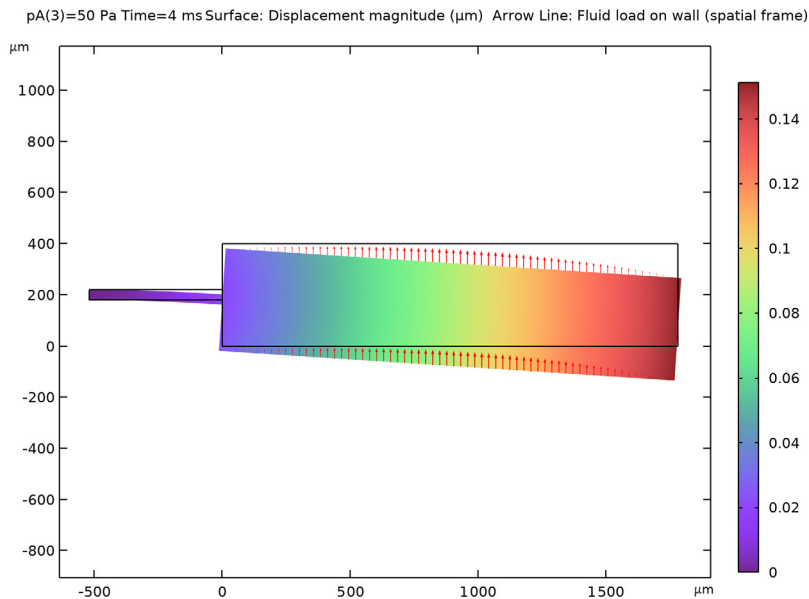

Next, plot the total force on the bottom face as a function of time for the three different values of the ambient pressure.

*Total Force on Bottom Surface (2D)*

1 In the **Results** toolbar, click  **ID Plot Group**.

- 2 In the **Settings** window for **ID Plot Group**, type Total Force on Bottom Surface (2D) in the **Label** text field.
- 3 Locate the **Data** section. From the **Dataset** list, choose **Study 1/ Parametric Solutions 1 (4) (sol2)**.
- 4 Locate the **Plot Settings** section.
- 5 Select the **x-axis label** checkbox. In the associated text field, type Time (ms).
- 6 Select the **y-axis label** checkbox. In the associated text field, type Total force, bottom face (uN).

*Global 1*

- 1 Right-click **Total Force on Bottom Surface (2D)** and choose **Global**.
- 2 In the **Settings** window for **Global**, locate the **y-Axis Data** section.
- 3 In the table, enter the following settings:

Expression	Unit	Description
F_bottom2d	uN	Total damping force, bottom face

- 4 Locate the **Legends** section. Find the **Include** subsection. Clear the **Description** checkbox.

5 In the **Total Force on Bottom Surface (2D)** toolbar, click  **Plot**.

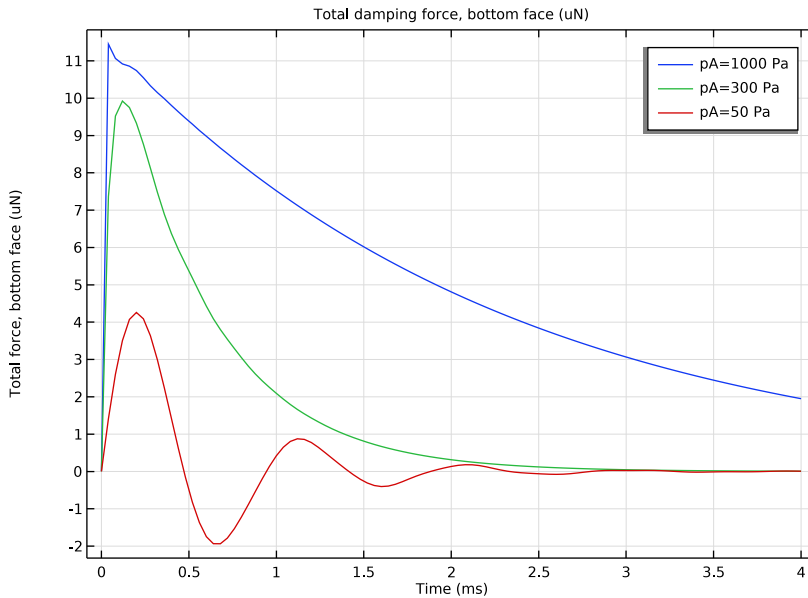

Finally, follow the steps below to plot the y displacement and the damping force at the proof mass tip versus time.

#### *Vertical Displacement (2D)*

- 1 In the **Results** toolbar, click  **ID Plot Group**.
- 2 In the **Settings** window for **ID Plot Group**, type **Vertical Displacement (2D)** in the **Label** text field.
- 3 Locate the **Data** section. From the **Dataset** list, choose **Study 1/ Parametric Solutions 1 (4) (sol2)**.
- 4 Locate the **Plot Settings** section.
- 5 Select the **x-axis label** checkbox. In the associated text field, type **Time (ms)**.
- 6 Select the **y-axis label** checkbox. In the associated text field, type **Displacement, z-component (microns)**.

#### *Point Graph 1*

- 1 Right-click **Vertical Displacement (2D)** and choose **Point Graph**.  
In the Selection list, click on **Manual** (the default option) to show the geometry in **Select Points** mode.

2 Select Point 7 only.

This is the proof mass's outer bottom corner.

3 In the **Settings** window for **Point Graph**, click **Replace Expression** in the upper-right corner of the **y-Axis Data** section. From the menu, choose **Component 2 (comp2) > Solid Mechanics 2 > Displacement > Displacement field - m > v2 - Displacement field, Y-component**.

4 In the **Vertical Displacement (2D)** toolbar, click  **Plot**.

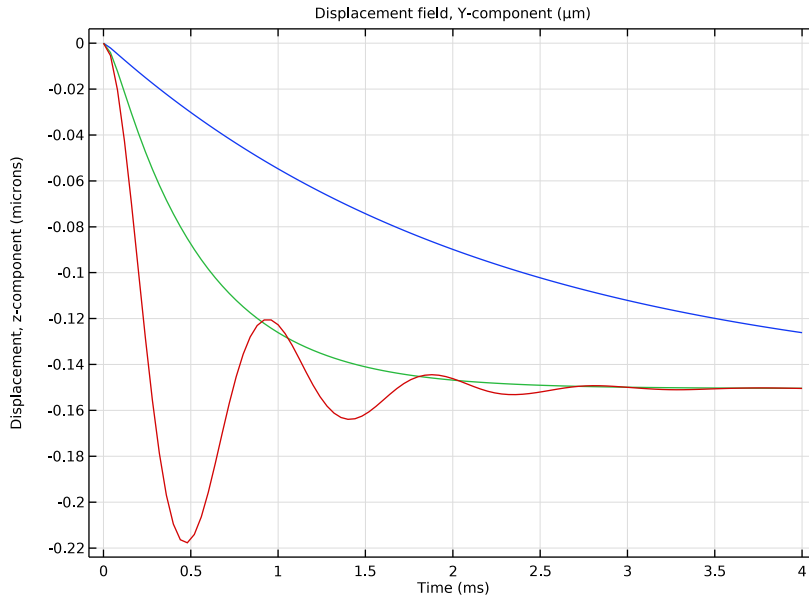

Vertical displacement of the proof mass tip versus time for different ambient pressure values.

5 Locate the **Legends** section. Find the **Include** subsection. Clear the **Point** checkbox.

6 Select the **Show legends** checkbox.