



Model created in COMSOL Multiphysics 6.4

# Piezoelectric Rate Gyroscope

## Introduction

This model shows how to analyze a tuning fork based piezoelectric rate gyroscope. The reverse piezoelectric effect is used to drive an in-plane tuning fork mode. This mode is coupled to an out of plane mode by the Coriolis force and the resulting out of plane motion is sensed by the direct piezoelectric effect. The geometry of the tuning forks is designed so that the eigenfrequencies of the nearby modes are separated in frequency space. The frequency response of the system is computed and the rotation rate sensitivity is evaluated. Note that the model focuses on the performance of the sensor in a uniformly rotating reference frame. The model is based on the detailed analysis of a similar device presented in [Ref. 1](#).

## Model Definition

[Figure 1](#) shows the geometry of the device indicating the key features.

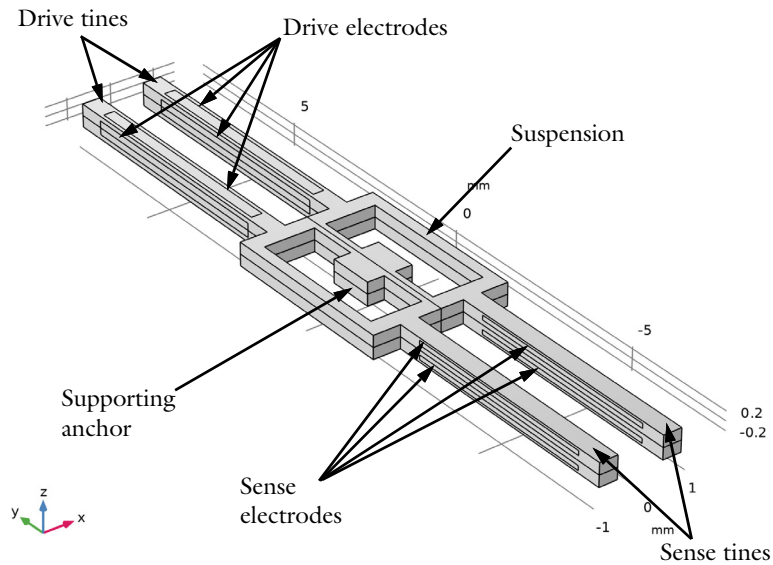

*Figure 1: Device geometry showing the plane of symmetry through the center of the device and the key components of the gyroscope.*

The packaging and fabrication of the device is discussed in [Ref. 1](#). Here we provide a simple explanation of its principle of operation when operated in a rotating frame with no angular acceleration ([Ref. 1](#) discusses the effects of an angular acceleration on the frequency response of the device in more detail). The gyroscope can be thought of as two

tuning forks, coupled together by a suspension structure. The suspension is anchored to the package of the device which is in turn attached to the rotating object. The drive tines are driven close to their resonance in an in-plane mode, as shown in [Figure 2](#). The sense tines are designed to have a resonance at a nearby, but distinct, frequency with a significant out of plane component to their motion, as shown in [Figure 3](#). As the drive mode vibrates in the in-plane direction within the rotating frame a Coriolis body force acts on the structure which excites the out of plane sense mode. The Coriolis force ( $\mathbf{F}_{\text{cor}}$ ) is given by:

$$\mathbf{F}_{\text{cor}} = -2\rho\Omega \times \frac{\partial \mathbf{u}}{\partial t}$$

where  $\rho$  is the density of the material,  $\Omega$  is the angular velocity of the rotating frame and  $\mathbf{u}$  is the local displacement of the structure. From the above equation it is clear that the Coriolis force is maximal when the angular velocity of the frame is parallel to the long in-plane axis of the gyroscope structure. In this case the resulting force is in the out of plane direction and produces a corresponding out of plane motion of the drive tines. This motion causes reaction moments in the supporting suspension which in turn transfers these moments to the sense tines — driving the sense mode. Note that in this model the angular velocity vector is assumed to be parallel to the long axis of the device.

The tines are fabricated from single crystal quartz wafers with the crystallographic  $Z$ -axis aligned parallel to the normal of the wafer plane. The details of the design are discussed in [Ref. 1](#), but the critical point is that the electrodes are patterned in such a way that both in-plane and in-phase out-of-plane motion of the sense tines is not detected by the sense electrodes. This leads to the rejection of unwanted signals in the output of the sensor.

In general, for resonant structures like this model, a very fine mesh is required to achieve accurate frequency response results. In the interest of saving time, we choose to use a relatively coarse mesh for this tutorial. As a result the resonant peak will shift if a more refined mesh is used instead.

## *Results and Discussion*

---

[Figure 2](#) shows the eigenmode corresponding to the drive mode and [Figure 3](#) shows that corresponding to the sense mode. Both the in-plane and out-of-plane motions of these modes are shown separately in the figures.

Eigenfrequency= $8397.1+0.2085i$  Hz Surface: Displacement field, X-component (mm) Surface: Displacement field, Z-component (mm)

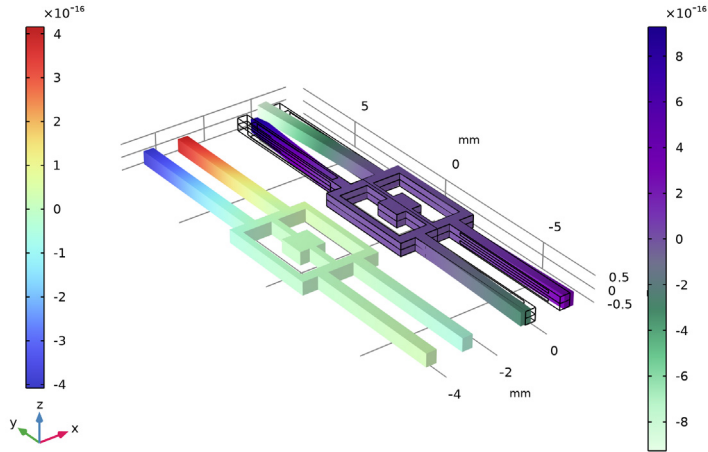

Figure 2: Drive mode, showing both in-plane motion (right) and out-of-plane motion (left). Note that the amplitude scale is arbitrary — only the relative value of the in-plane and out-of-plane displacements has physical significance.

Eigenfrequency= $10631+0.25849i$  Hz Surface: Displacement field, X-component (mm) Surface: Displacement field, Z-component (mm)

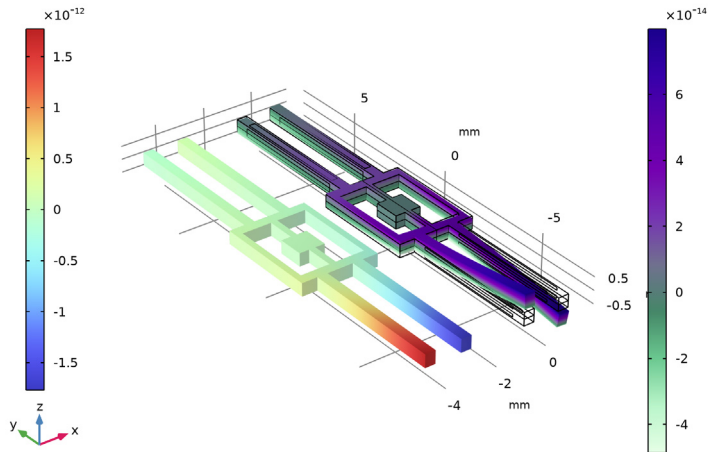

Figure 3: Sense mode, showing out-of-plane motion (left) and in-plane motion (right). Note that the amplitude scale is arbitrary — only the relative value of the in-plane and out-of-plane displacements has physical significance.

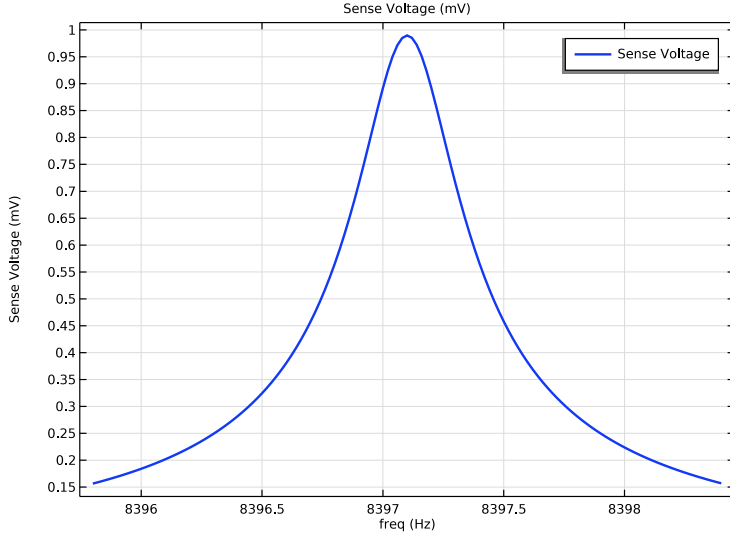

Figure 4: Sense voltage vs. drive frequency with an applied sinusoidal drive voltage of amplitude 2 V and an angular acceleration of 64 deg/s.

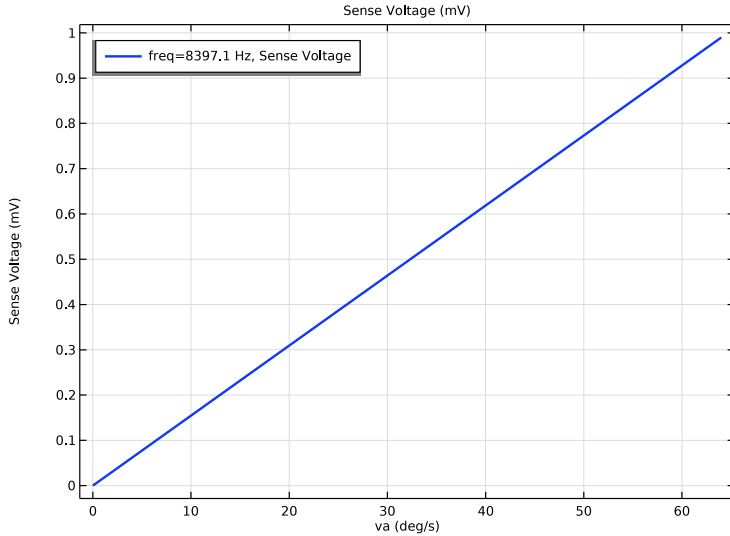

Figure 5: Sense voltage vs. angular acceleration at a drive voltage amplitude of 2 V and a frequency of 8396 Hz.

Figure 4 shows the response of the device as the frequency of the drive voltage waveform is varied. A clear peak in the response close to the drive frequency, at approximately 8396 Hz is apparent. This is the optimum drive frequency for the device. Figure 5 shows the sense voltage against the angular acceleration with a 2 V drive voltage at a frequency close to this optimum. As expected the response of the sensor is linear in this operation range, with a sensitivity of approximately 0.015 mV / (deg/s).

### Reference

---

I. S.D. Senturia, “A Piezoelectric Rate Gyroscope,” *Microsystem Design*, chapter 21, Springer, 2000.

---

**Application Library path:** MEMS\_Module/Piezoelectric\_Devices/  
piezoelectric\_rate\_gyroscope

---

### Modeling Instructions



---

From the **File** menu, choose **New**.

#### NEW

In the **New** window, click  **Model Wizard**.

#### MODEL WIZARD

- 1 In the **Model Wizard** window, click  **3D**.
- 2 In the **Select Physics** tree, select **Structural Mechanics > Electromagnetics–Structure Interaction > Piezoelectricity > Piezoelectricity, Solid**.
- 3 Click **Add**.
- 4 Click  **Study**.
- 5 In the **Select Study** tree, select **Preset Studies for Selected Multiphysics > Eigenfrequency**.
- 6 Click  **Done**.

#### GEOMETRY I

Add some global parameters.

## GLOBAL DEFINITIONS

### Parameters 1

- 1 In the **Model Builder** window, under **Global Definitions** click **Parameters 1**.
- 2 In the **Settings** window for **Parameters**, locate the **Parameters** section.
- 3 In the table, enter the following settings:

Name	Expression	Value	Description
va	64[deg/s]	1.117 rad/s	Rotation angular velocity



Build a symmetric mesh for this model so that the numerical result for no rotation will be very close to the expected null result. To prevent the symmetry of the mesh from being broken, clear the **Avoid inverted elements by curving interior domain elements** checkbox.

## COMPONENT 1 (COMP1)

- 1 In the **Model Builder** window, click **Component 1 (comp1)**.
- 2 In the **Settings** window for **Component**, locate the **Curved Mesh Elements** section.
- 3 Clear the **Avoid inverted elements by curving interior domain elements** checkbox.

Import the geometry from file.

## GEOMETRY 1

- 1 In the **Model Builder** window, under **Component 1 (comp1)** click **Geometry 1**.
- 2 In the **Settings** window for **Geometry**, locate the **Units** section.
- 3 From the **Length unit** list, choose **mm**.
- 4 In the **Geometry** toolbar, click **Insert Sequence** and choose **Insert Sequence**.
- 5 Browse to the model's Application Libraries folder and double-click the file `piezoelectric_rate_gyroscope_geom_sequence.mph`.
- 6 In the **Geometry** toolbar, click  **Build All**.
- 7 Click the  **Zoom Extents** button in the **Graphics** toolbar.

The **Adaptive Frequency Sweep** study step will generate a high resolution frequency sweep. To avoid large file size, create an "explicit selection" to store solution data only on the external surfaces of the modeling domain.

## DEFINITIONS



### External surfaces

- 1 In the **Definitions** toolbar, click  **Explicit**.

- 2 In the **Settings** window for **Explicit**, locate the **Input Entities** section.
- 3 Select the **All domains** checkbox.
- 4 Locate the **Output Entities** section. From the **Output entities** list, choose **Adjacent boundaries**.
- 5 In the **Label** text field, type External surfaces.

Add the built-in quartz material.

#### ADD MATERIAL

- 1 In the **Home** toolbar, click  **Add Material** to open the **Add Material** window.
- 2 Go to the **Add Material** window.
- 3 In the tree, select **Piezoelectric > Quartz LH (1978 IEEE)**.
- 4 Click the **Add to Component** button in the window toolbar.
- 5 In the **Home** toolbar, click  **Add Material** to close the **Add Material** window.

Set up the physics.

#### SOLID MECHANICS (SOLID)

##### *Mechanical Damping I*

- 1 In the **Physics** toolbar, click  **Attributes** and choose **Mechanical Damping**.
- 2 In the **Settings** window for **Mechanical Damping**, locate the **Damping Settings** section.
- 3 From the **Damping type** list, choose **Isotropic loss factor**.
- 4 From the  $\eta_s$  list, choose **User defined**. In the associated text field, type 5e-5.

Anchor the circular region underneath the structure.

##### *Fixed Constraint I*

- 1 In the **Physics** toolbar, click  **Boundaries** and choose **Fixed Constraint**.
- 2 Select Boundaries 48 and 60 only.

Add rotating frame physics.

##### *Rotating Frame I*

- 1 In the **Physics** toolbar, click  **Domains** and choose **Rotating Frame**.
- 2 In the **Settings** window for **Rotating Frame**, locate the **Rotating Frame** section.
- 3 From the **Axis of rotation** list, choose **y-axis**.
- 4 In the  $\omega_r$  text field, type va.
- 5 Locate the **Frame Acceleration Effect** section. Select the **Coriolis force** checkbox.

## ELECTROSTATIC (ES)

Add boundary conditions for the drive and sense electrodes.

### *Drive Terminal 1*

- 1 In the **Physics** toolbar, click  **Boundaries** and choose **Boundary Terminal**.
- 2 In the **Settings** window for **Boundary Terminal**, type Drive Terminal 1 in the **Label** text field.
- 3 Select Boundaries 28, 29, 85, 86, 101, and 102 only.
- 4 Locate the **Terminal** section. From the **Terminal type** list, choose **Voltage**.

### *Drive Terminal 2*

- 1 In the **Physics** toolbar, click  **Boundaries** and choose **Boundary Terminal**.
- 2 In the **Settings** window for **Boundary Terminal**, type Drive Terminal 2 in the **Label** text field.
- 3 Select Boundaries 24, 25, 46, 47, 89, and 90 only.
- 4 Locate the **Terminal** section. From the **Terminal type** list, choose **Voltage**.
- 5 In the  $V_0$  text field, type -1.

### *Sense Terminal 1*

- 1 In the **Physics** toolbar, click  **Boundaries** and choose **Boundary Terminal**.
- 2 In the **Settings** window for **Boundary Terminal**, type Sense Terminal 1 in the **Label** text field.
- 3 Select Boundaries 21, 32, 79, and 94 only.

### *Sense Terminal 2*

- 1 In the **Physics** toolbar, click  **Boundaries** and choose **Boundary Terminal**.
- 2 In the **Settings** window for **Boundary Terminal**, type Sense Terminal 2 in the **Label** text field.
- 3 Select Boundaries 20, 33, 80, and 93 only.

Build a symmetric mesh for this model so that the numerical result for no rotation will be very close to the expected null result. To save computation time and to reduce file size, a relatively coarse mesh is used.

## MESH 1

- 1 In the **Model Builder** window, under **Component 1 (comp1)** click **Mesh 1**.
- 2 In the **Settings** window for **Mesh**, locate the **Physics-Controlled Mesh** section.
- 3 From the **Element size** list, choose **Finer**.

- 4 Locate the **Sequence Type** section. From the list, choose **User-controlled mesh**.

#### *Size*

- 1 In the **Model Builder** window, under **Component 1 (comp1) > Mesh 1** click **Size**.
- 2 In the **Settings** window for **Size**, locate the **Element Size Parameters** section.
- 3 In the **Maximum element size** text field, type  $tQz/4$ .
- 4 In the **Minimum element size** text field, type  $tQz/12$ .

#### *Free Tetrahedral 1*

- 1 In the **Model Builder** window, click **Free Tetrahedral 1**.
- 2 In the **Settings** window for **Free Tetrahedral**, locate the **Domain Selection** section.
- 3 From the **Geometric entity level** list, choose **Domain**.
- 4 Select Domain 1 only.

#### *Copy Domain 1*

- 1 In the **Model Builder** window, right-click **Mesh 1** and choose **Copying Operations > Copy Domain**.
- 2 Select Domain 1 only.
- 3 In the **Settings** window for **Copy Domain**, locate the **Destination Domains** section.
- 4 Click to select the  **Activate Selection** toggle button.
- 5 Select Domains 2–4 only.

6 In the **Mesh** toolbar, click  **Build Mesh**.

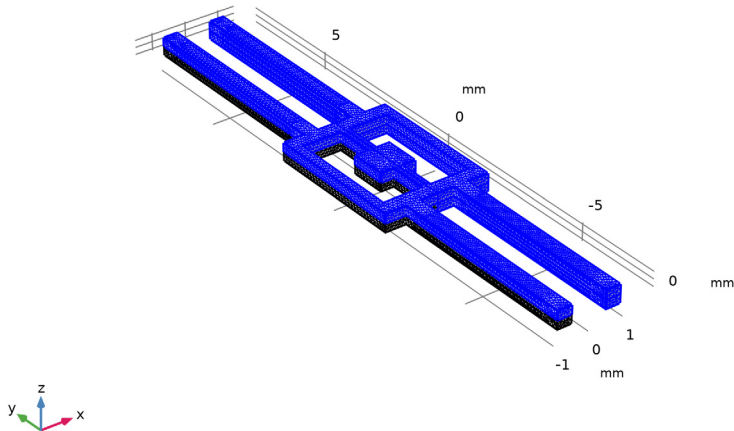

Set up the eigenfrequency study to solve for the eigenmodes.

### EIGENMODES

- 1 In the **Model Builder** window, click **Study 1**.
- 2 In the **Settings** window for **Study**, type Eigenmodes in the **Label** text field.

#### *Step 1: Eigenfrequency*

- 1 In the **Model Builder** window, under **Eigenmodes** click **Step 1: Eigenfrequency**.
- 2 In the **Settings** window for **Eigenfrequency**, locate the **Study Settings** section.
- 3 Select the **Desired number of eigenfrequencies** checkbox. In the associated text field, type 9.
- 4 In the **Search for eigenfrequencies around shift** text field, type  $3e3$ .
- 5 From the **Search method around shift** list, choose **Larger real part**.
- 6 In the **Study** toolbar, click  **Compute**.

## RESULTS

### *Mode Shape (solid)*

The default mode shape plot shows a surface plot of the displacement magnitude. To provide a deeper insight into the mode shapes, plot the  $x$  and  $z$  displacements in two separate surface plots instead.

Change the default surface plot to plot the  $x$  displacement.

### *Surface 1*

- 1 In the **Model Builder** window, expand the **Mode Shape (solid)** node, then click **Surface 1**.
- 2 In the **Settings** window for **Surface**, locate the **Expression** section.
- 3 In the **Expression** text field, type  $u$ .  
Duplicate the surface plot to plot the  $z$  displacement.

### *Surface 2*

- 1 Right-click **Results > Mode Shape (solid) > Surface 1** and choose **Duplicate**.
- 2 In the **Settings** window for **Surface**, locate the **Expression** section.
- 3 In the **Expression** text field, type  $w$ .
- 4 Locate the **Coloring and Style** section. From the **Color table** list, choose **RainbowLight**.

### *Deformation*

- 1 In the **Model Builder** window, expand the **Surface 2** node, then click **Deformation**.
- 2 In the **Settings** window for **Deformation**, locate the **Expression** section.
- 3 In the **x-component** text field, type  $-w_f * 1.3$ .
- 4 In the **y-component** text field, type  $0$ .
- 5 In the **z-component** text field, type  $0$ .
- 6 Locate the **Scale** section.
- 7 Select the **Scale factor** checkbox. In the associated text field, type  $1$ .

### *Mode Shape (solid)*

Turn on color legend to see the relative amplitude of the  $x$  and  $z$  displacements.

- 1 In the **Model Builder** window, under **Results** click **Mode Shape (solid)**.
- 2 In the **Settings** window for **3D Plot Group**, locate the **Color Legend** section.
- 3 Select the **Show legends** checkbox.
- 4 From the **Position** list, choose **Alternating**.  
Plot the mode shape of the drive mode.

5 Locate the **Data** section. From the **Eigenfrequency (Hz)** list, choose **8397.1+0.2085i**.

6 In the **Mode Shape (solid)** toolbar, click  **Plot**.

7 Click the  **Zoom Extents** button in the **Graphics** toolbar.

Plot the sense mode, which is at a higher frequency.

8 From the **Eigenfrequency (Hz)** list, choose **10631+0.25849i**.

9 In the **Mode Shape (solid)** toolbar, click  **Plot**.

10 Click the  **Zoom Extents** button in the **Graphics** toolbar.

Set up and solve an **Adaptive Frequency Sweep** study, which is optimized for resolving narrow resonant peaks without excessive computation.

#### ADD STUDY

1 In the **Home** toolbar, click  **Add Study** to open the **Add Study** window.

2 Go to the **Add Study** window.

3 Find the **Studies** subsection. In the **Select Study** tree, select **Empty Study**.

4 Click the **Add Study** button in the window toolbar.

5 In the **Home** toolbar, click  **Add Study** to close the **Add Study** window.

#### FREQUENCY RESPONSE

1 In the **Settings** window for **Study**, type Frequency Response in the **Label** text field.

2 Locate the **Study Settings** section. Clear the **Generate default plots** checkbox.

*Step 1: Adaptive Frequency Sweep*

1 In the **Study** toolbar, click  **More Study Steps** and choose **Frequency Domain > Adaptive Frequency Sweep**.

2 In the **Settings** window for **Adaptive Frequency Sweep**, locate the **Study Settings** section.

3 In the **Frequencies** text field, type range (-1.3, 0.02, 1.3)+8397.1.

4 From the **AWE expression type** list, choose **User controlled**.

5 In the table, enter the following settings:

---

#### Asymptotic waveform evaluation (AWE) expressions

---

`abs(comp1.es.V0_4-comp1.es.V0_3)/1[mV]`

---

To reduce file size, only store solution data on the external surfaces.

6 Click to expand the **Store in Output** section. In the table, enter the following settings:

Interface	Output
Solid Mechanics (solid)	Selection

7 Click to select row number 1 in the table.

8 Under **Selections**, click  **Add**.

9 In the **Add** dialog, select **External surfaces** in the **Selections** list.

10 Click **OK**.

11 In the **Settings** window for **Adaptive Frequency Sweep**, locate the **Store in Output** section.

12 In the table, enter the following settings:

Interface	Output
Electrostatics (es)	Selection

13 Click to select row number 2 in the table.

14 Under **Selections**, click  **Add**.

15 In the **Add** dialog, select **External surfaces** in the **Selections** list.

16 Click **OK**.

17 In the **Study** toolbar, click  **Compute**.

Create plots to visualize the frequency response of the displacement and the sense voltage.

## RESULTS

### *Frequency Response: Displacement*

1 Right-click **Mode Shape (solid)** and choose **Duplicate**.

2 In the **Settings** window for **3D Plot Group**, type Frequency Response: Displacement in the **Label** text field.

3 Locate the **Data** section. From the **Dataset** list, choose **Frequency Response/Solution 2 (sol2)**.

4 In the **Frequency Response: Displacement** toolbar, click  **Plot**.

### *Frequency Response: Sense Voltage*

1 In the **Results** toolbar, click  **ID Plot Group**.

2 In the **Settings** window for **ID Plot Group**, type Frequency Response: Sense Voltage in the **Label** text field.

- 3 Locate the **Data** section. From the **Dataset** list, choose **Frequency Response/ Solution 2 (sol2)**.

*Sense Voltage*



- 1 Right-click **Frequency Response: Sense Voltage** and choose **Global**.
- 2 In the **Settings** window for **Global**, type **Sense Voltage** in the **Label** text field.
- 3 Locate the **y-Axis Data** section. In the table, enter the following settings:

Expression	Unit	Description
$\text{abs}(es.V0\_4 - es.V0\_3)$	mV	Sense Voltage

- 4 Click to expand the **Coloring and Style** section. From the **Width** list, choose **2**.
- 5 In the **Frequency Response: Sense Voltage** toolbar, click  **Plot**.

Add a study and make a plot to evaluate the sensitivity of the device.

**ADD STUDY**

- 1 In the **Home** toolbar, click  **Add Study** to open the **Add Study** window.
- 2 Go to the **Add Study** window.
- 3 Find the **Studies** subsection. In the **Select Study** tree, select **General Studies > Frequency Domain**.
- 4 Click the **Add Study** button in the window toolbar.
- 5 In the **Home** toolbar, click  **Add Study** to close the **Add Study** window.

**STUDY 3**

*Step 1: Frequency Domain*

- 1 In the **Settings** window for **Frequency Domain**, locate the **Study Settings** section.
- 2 In the **Frequencies** text field, type **8397.1**.
- 3 Click to expand the **Study Extensions** section. Select the **Auxiliary sweep** checkbox.
- 4 Click  **Add**.
- 5 In the table, enter the following settings:

Parameter name	Parameter value list	Parameter unit
va (Rotation angular velocity)	0 32 64	deg/s

- 6 In the **Model Builder** window, click **Study 3**.
- 7 In the **Settings** window for **Study**, locate the **Study Settings** section.

- 8 Clear the **Generate default plots** checkbox.
- 9 In the **Label** text field, type **Sensitivity**.
- 10 In the **Study** toolbar, click  **Compute**.

## RESULTS

*Sensitivity: Sense Voltage vs. Angular Velocity*

- 1 In the **Model Builder** window, right-click **Frequency Response: Sense Voltage** and choose **Duplicate**.
- 2 In the **Settings** window for **ID Plot Group**, locate the **Data** section.
- 3 From the **Dataset** list, choose **Sensitivity/Solution 3 (sol3)**.
- 4 Locate the **Legend** section. From the **Position** list, choose **Upper left**.
- 5 In the **Label** text field, type **Sensitivity: Sense Voltage vs. Angular Velocity**.

*Sense Voltage*

- 1 In the **Model Builder** window, expand the **Sensitivity: Sense Voltage vs. Angular Velocity** node, then click **Sense Voltage**.
- 2 In the **Settings** window for **Global**, locate the **x-Axis Data** section.
- 3 From the **Unit** list, choose **deg/s**.
- 4 In the **Sensitivity: Sense Voltage vs. Angular Velocity** toolbar, click  **Plot**.