



Model created in COMSOL Multiphysics 6.4

Hysteresis in Piezoelectric Ceramics

Introduction

Many piezoelectric materials are ferroelectric. Ferroelectric materials exhibit nonlinear polarization behavior such as hysteresis and saturation at large applied electric fields. In addition, the polarization and mechanical deformations in such materials can be strongly coupled due to the electrostriction effect. This model uses the Ferroelectroelasticity interface to analyze a simple actuator made of PZT piezoelectric ceramic material, which is subjected to applied electric field and mechanical load.

Model Definition

The direct electrostrictive effect for a material of arbitrary symmetry can be represented as the following additive contribution to the strain:

$$\varepsilon_{em} = \mathbf{Q} : (\mathbf{P} \otimes \mathbf{P})$$

which is quadratic in polarization \mathbf{P} . Due to the symmetry, the fourth order tensor \mathbf{Q} can be effectively represented by a 6-by-6 coupling matrix. For piezoelectric ceramics, the matrix can be characterized by three independent components: Q_{11} , Q_{12} , and Q_{44} .

For ferroelectroelastic materials, the polarization vector is nonlinear function of the electric field and possible mechanical stress in the material. The Jiles–Atherton model is available in COMSOL Multiphysics for modeling ferroelectric hysteresis. It assumes that the total polarization can be represented as a sum of reversible and irreversible parts. The polarization change is computed from the following incremental equation:

$$d\mathbf{P} = c_r d\mathbf{P}_{an} + (1 - c_r) d\mathbf{P}_{irr}$$

where the reversibility is characterized by the parameter c_r , and the anhysteretic polarization is found from a relation:

$$\mathbf{P}_{an} = P_s L(|\mathbf{E}_{eff}|) \frac{\mathbf{E}_{eff}}{|\mathbf{E}_{eff}|}$$

where P_s is the saturation polarization. The polarization shape is characterized by the Langevin function

$$L = \coth\left(\frac{|\mathbf{E}_{eff}|}{a}\right) - \frac{a}{|\mathbf{E}_{eff}|}$$

where a is a material parameter called the domain wall density.

The effective electric field is given by

$$\mathbf{E}_{\text{eff}} = \mathbf{E} + \alpha \mathbf{P} + 2(\sigma_{\text{m}} : \mathbf{Q}) \mathbf{P} \quad (1)$$

where \mathbf{E} is the applied electric field, α is a material parameter called the inter-domain coupling, and the mechanics stress is computed assuming mechanically linear material as

$$\sigma_{\text{m}} = \mathbf{C} : (\boldsymbol{\varepsilon} - \boldsymbol{\varepsilon}_{\text{em}})$$

where \mathbf{C} is the fourth order elasticity tensor. The last term in [Equation 1](#) represents the inverse electrostrictive effect.

Finally, the change of the irreversible polarization is computed from the following incremental relation:

$$d\mathbf{P}_{\text{irr}} = \max(\zeta \cdot d\mathbf{E}_{\text{eff}}, 0) \frac{\zeta}{|\zeta|}$$

$$\zeta = \mathbf{k}_p^{-1} (\mathbf{P}_{\text{an}} - \mathbf{P}_{\text{irr}})$$

where the pinning loss is characterized by the parameter \mathbf{k}_p .

The ferroelectroelastic actuator in this model example is a rectangular plate with dimensions of 1.5 in-by-0.25 in-by-0.015 in, which is composed of PZT-5H piezoelectric ceramic material. The following polarization parameter values have been estimated in [Ref. 1](#) based on experimental data:

TABLE 1: MATERIAL PROPERTIES OF PZT-5H.

MATERIAL PROPERTY	VALUE	DESCRIPTION
P_s	0.425 C/m ²	Saturation polarization
a	6.410 ⁵ V/m	Domain wall density
α	4.2·10 ⁶ m/F	Inter-domain coupling
c_r	0.2	Polarization reversibility
\mathbf{k}_p	1·10 ⁶ V/m	Pinning loss

The mechanical properties for PZT-5H are available in the Material Library of COMSOL.

The coupling coefficients for PZT ceramics can vary with the material composition and temperature. The reference values used in this example are given in the table below (Ref. 2).

TABLE 2: ELECTROSTRICTIVE COUPLING COEFFICIENTS.

MATERIAL PROPERTY	VALUE
Q_{11}	$3.579 \cdot 10^{-2} \text{ m}^4/\text{C}^2$
Q_{12}	$-5.335 \cdot 10^{-3} \text{ m}^4/\text{C}^2$
Q_{44}	$1.923 \cdot 10^{-2} \text{ m}^4/\text{C}^2$

The upper surface of the actuator is grounded, while the lower one is subjected to an electric potential that can cyclically vary in small increments between $-V_{\text{max}}$ and $+V_{\text{max}}$.

The actuator can be subjected to a compressive stress by applying boundary loads of various magnitude.

Because of the symmetry, it is sufficient to model one quarter of the actual geometry.

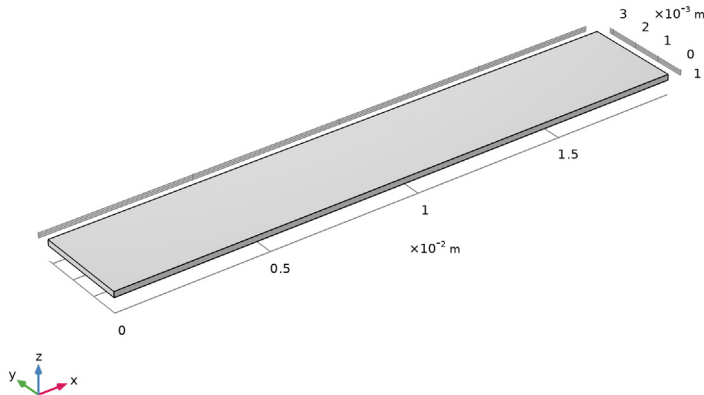

Figure 1: Model geometry.

Because of the large aspect ratio of the actuator and the unidirectional nature of the electrical and mechanical loading, a coarse mesh can be used for the discretization.

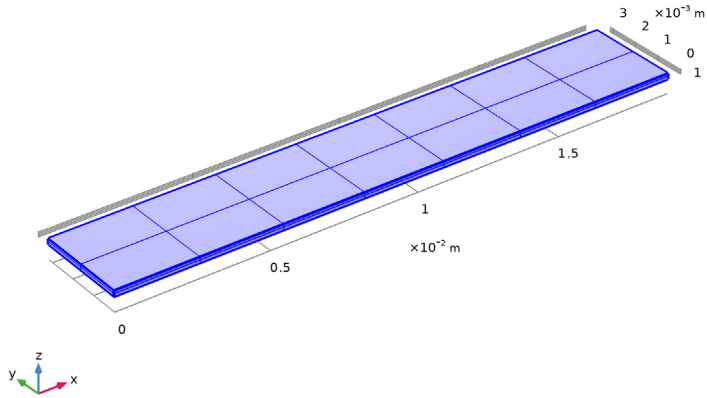

Figure 2: Model mesh.

Results and Discussion

Three full cycles have been computed for each value of V_{\max} . The variation of polarization and electrostrictive strain is studied at the point in the middle of the actuator. The first cycle includes the initial transient; see [Figure 3](#) and [Figure 4](#). The hysteresis loops become fully established after two full cycles; see [Figure 5](#) and [Figure 6](#).

Finally, [Figure 7](#) and [Figure 8](#) show the effect of the applied compressive stress.

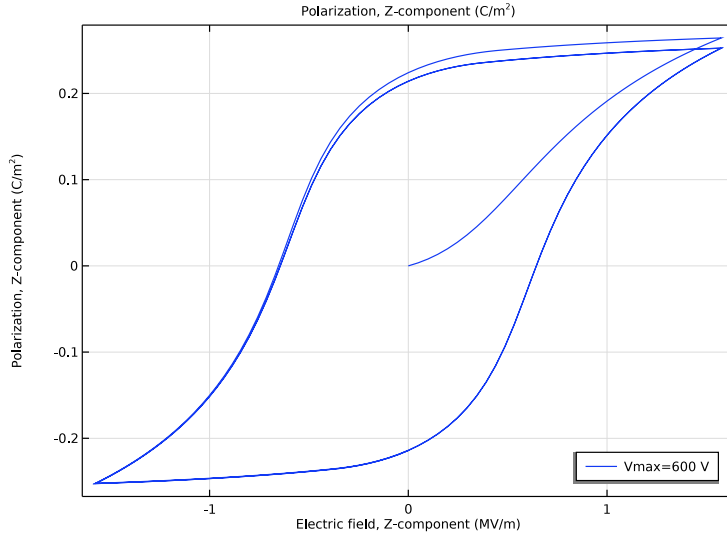

Figure 3: Polarization hysteresis loop including the initial transient for the maximum applied voltage of 600 V.

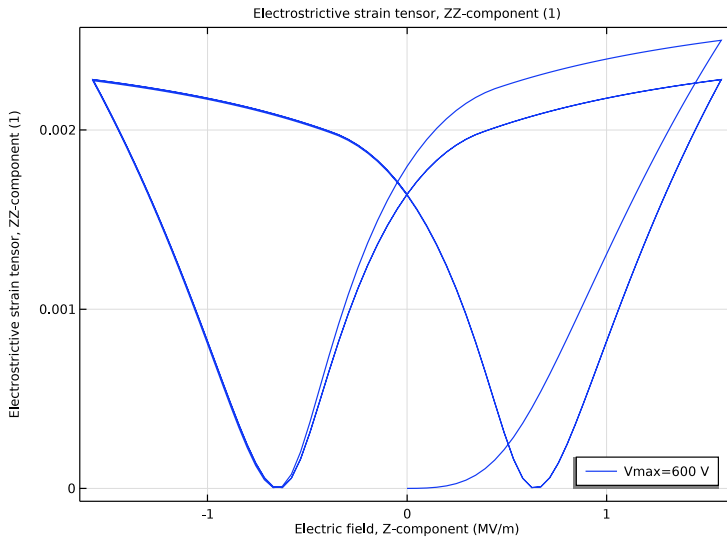

Figure 4: Electrostrictive strain hysteresis loop including the initial transient for the maximum applied voltage of 600 V.

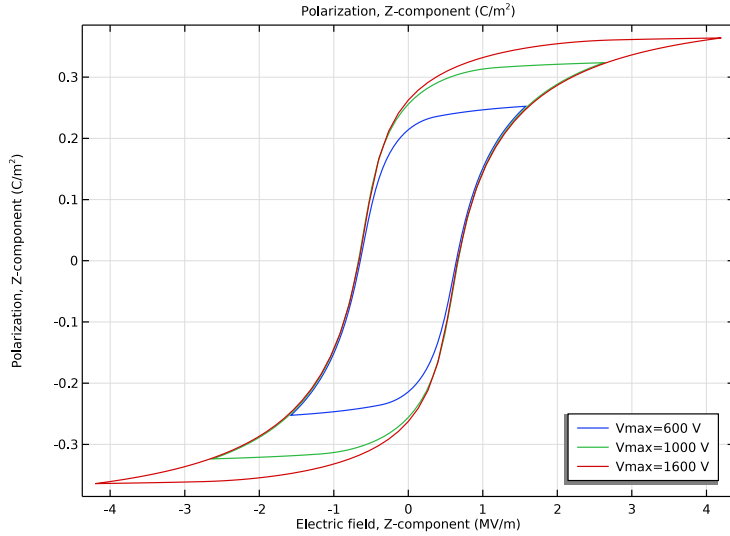

Figure 5: Polarization hysteresis loops fully established after two initial cycles for different values of the maximum applied voltage.

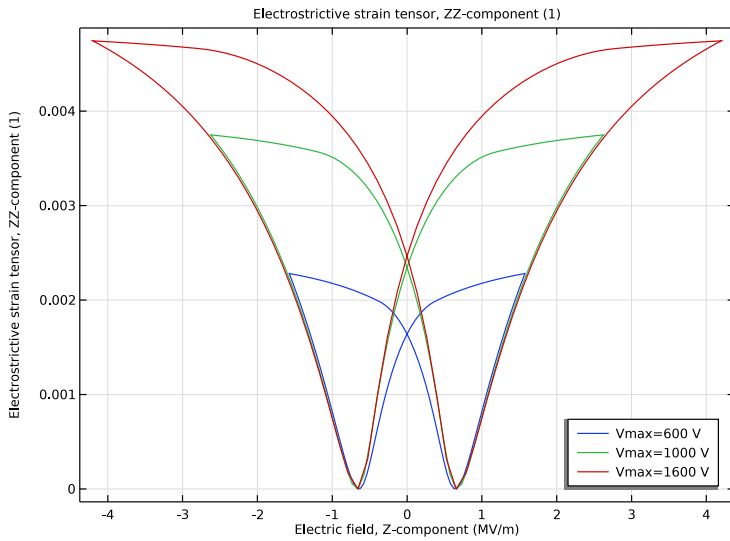

Figure 6: Electrostrictive strain hysteresis loops fully established after two initial cycles for different values of the maximum applied voltage.

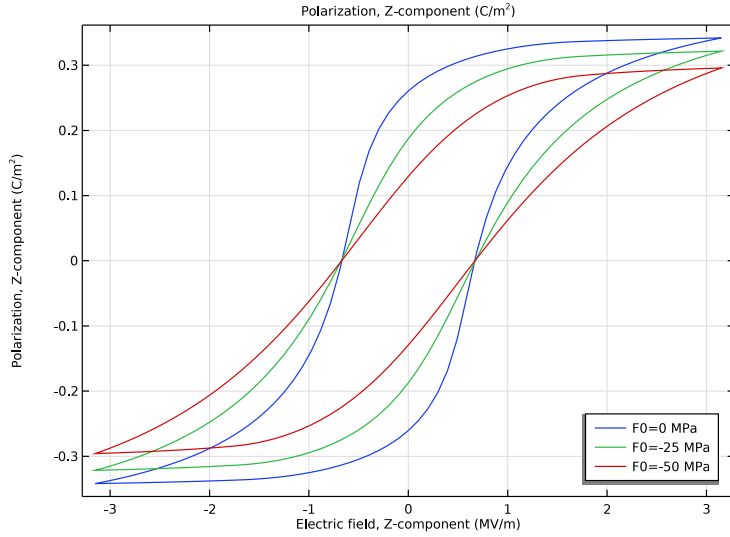

Figure 7: Fully established polarization hysteresis loops for different values of the mechanical load and maximum applied voltage of 1200 V.

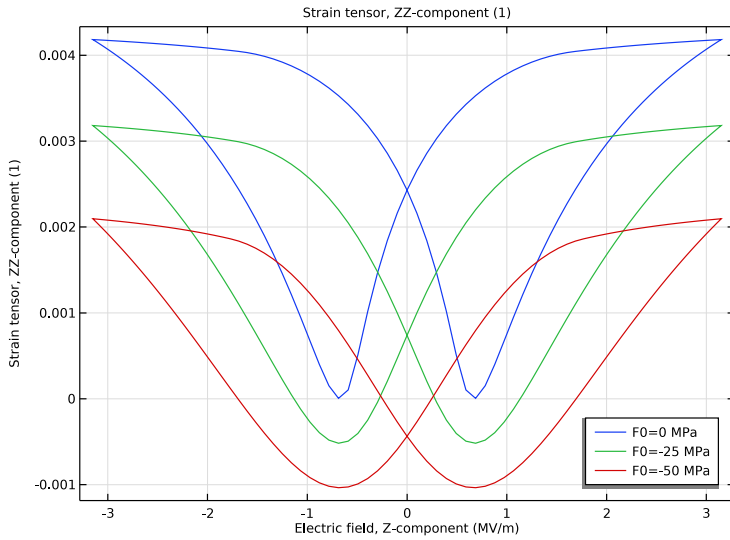

Figure 8: Fully established strain hysteresis loops for different values of the mechanical load and maximum applied voltage of 1200 V.

Notes About the COMSOL Implementation

In this example, you study the hysteresis with respect to the incremental variation of the applied electric potential using a stationary parametric study. The same hysteresis model can be also used for time dependent studies.

References

1. R.C. Smith and Z. Ounaies. “A Domain Wall Model for Hysteresis in Piezoelectric Materials,” *J. Int. Mat. Sys. Struct.*, vol. 11, no. 1, pp. 62–79, 2000.
2. B. Völker, P. Marton, C. Elsässer, and M. Kamlah, “Multiscale modeling for ferroelectric materials: a transition from the atomic level to phase-field modeling,” *Continuum Mech. Thermodyn.*, vol. 23, pp. 435–451, 2011.

Application Library path: MEMS_Module/Piezoelectric_Devices/
piezoelectric_hysteresis



Modeling Instructions

From the **File** menu, choose **New**.

NEW

In the **New** window, click  **Model Wizard**.

MODEL WIZARD

- 1 In the **Model Wizard** window, click  **3D**.
- 2 In the **Select Physics** tree, select **Structural Mechanics > Electromagnetics–Structure Interaction > Ferroelectroelasticity**.
- 3 Click **Add**.
- 4 Click  **Study**.
- 5 In the **Select Study** tree, select **General Studies > Stationary**.
- 6 Click  **Done**.

GLOBAL DEFINITIONS

Parameters 1

Define parameters for the geometry, material properties, applied voltage, and mechanical load.

- 1 In the **Model Builder** window, under **Global Definitions** click **Parameters 1**.
- 2 In the **Settings** window for **Parameters**, locate the **Parameters** section.
- 3 In the table, enter the following settings:

Name	Expression	Value	Description
t	0[s]	0 s	Time parameter
W	1.5[in]	0.0381 m	Actuator width
D	0.25[in]	0.00635 m	Actuator depth
H	0.015[in]	3.81E-4 m	Actuator height
alpha	4.2e6[m/F]	4.2E6 m/F	Interdomain coupling
a	6.4e5[V/m]	6.4E5 V/m	Domain wall density
c	0.2	0.2	Polarization reversibility
k	1e6[V/m]	1E6 V/m	Pinning loss
Ps	0.425[C/ m ²]	0.425 C/ m ²	Saturation polarization
Q11	3.579e- 2[m ⁴ /C ²]	0.03579 m ⁴ /C ²	Electrostriction coupling parameter
Q12	-5.335e- 3[m ⁴ /C ²]	-0.005335 m ⁴ /C ²	Electrostriction coupling parameter
Q44	1.923e- 2[m ⁴ /C ²]	0.01923 m ⁴ /C ²	Electrostriction coupling parameter
Vmax	1200[V]	1200 V	Maximum applied voltage
F0	0[MPa]	0 Pa	Applied mechanical load

DEFINITIONS

Variables 1

- 1 In the **Model Builder** window, under **Component 1 (comp1)** right-click **Definitions** and choose **Variables**.
- 2 In the **Settings** window for **Variables**, locate the **Variables** section.

3 In the table, enter the following settings:

Name	Expression	Unit	Description
V0	$V_{max} \cdot \sin(2 \cdot \pi \cdot t [1/s])$	V	Applied voltage

This variation of the potential with respect to the parameter at one of the actuator boundaries will cause the electric field within the material to gradually change between $-V_{max}$ and V_{max} .

GEOMETRY I

Block 1 (blk1)

1 In the **Geometry** toolbar, click  **Block**.

Because of the symmetry, it is sufficient to model one quarter of the actuator.

2 In the **Settings** window for **Block**, locate the **Size and Shape** section.

3 In the **Width** text field, type $W/2$.

4 In the **Depth** text field, type $D/2$.

5 In the **Height** text field, type $H/2$.

6 Click  **Build All Objects**.

SOLID MECHANICS (SOLID)

Linear Elastic Material 1

Prescribe the material stiffness using data available in the material library for PZT-5H, which is represented by the full elasticity matrix.

1 In the **Model Builder** window, under **Component 1 (comp1) > Solid Mechanics (solid)** click **Linear Elastic Material 1**.

2 In the **Settings** window for **Linear Elastic Material**, locate the **Linear Elastic Material** section.

3 From the **Material symmetry** list, choose **Anisotropic**.

4 From the **Material data ordering** list, choose **Voigt (11, 22, 33, 23, 13, 12)**.



ELECTROSTATICS (ES)

Charge Conservation, Ferroelectric 1

1 In the **Model Builder** window, under **Component 1 (comp1) > Electrostatics (es)** click **Charge Conservation, Ferroelectric 1**.

- 2 In the **Settings** window for **Charge Conservation, Ferroelectric**, locate the **Ferroelectric Material Properties** section.
- 3 Select the **Hysteresis Jiles–Atherton model** checkbox.

ADD MATERIAL

- 1 In the **Materials** toolbar, click  **Add Material** to open the **Add Material** window.
- 2 Go to the **Add Material** window.
- 3 In the tree, select **Built-in > Lead Zirconate Titanate (PZT-5H)**.
- 4 Right-click and choose **Add to Component 1 (comp1)**.
- 5 In the **Materials** toolbar, click  **Add Material** to close the **Add Material** window.

MATERIALS

Lead Zirconate Titanate (PZT-5H) (mat1)

Define the remaining ferroelectric properties for the material using the parameters.

- 1 In the **Settings** window for **Material**, locate the **Material Contents** section.
- 2 In the table, enter the following settings:

Property	Variable	Value	Unit	Property group
Saturation polarization	Psat	Ps	C/m ²	Ferroelectric
Interdomain coupling	alphaJ _{Ae_iso} ; alphaJ _{Aeii} = alphaJ _{Ae_iso} , alphaJ _{Aeij} = 0	alpha	m/F	Ferroelectric
Domain wall density	aJ _{Ae_iso} ; aJ _{Aeii} = aJ _{Ae_iso} , aJ _{Aeij} = 0	a	V/m	Ferroelectric
Pinning loss	kJ _{Ae_iso} ; kJ _{Aeii} = kJ _{Ae_iso} , kJ _{Aeij} = 0	k	V/m	Ferroelectric
Polarization reversibility	cJ _{Ae_iso} ; cJ _{Aeii} = cJ _{Ae_iso} , cJ _{Aeij} = 0	c	I	Ferroelectric

SOLID MECHANICS (SOLID)

Symmetry 1

- 1 In the **Physics** toolbar, click  **Boundaries** and choose **Symmetry**.
- 2 Select Boundaries 1–3 only.

Boundary Load 1

- 1 In the **Physics** toolbar, click  **Boundaries** and choose **Boundary Load**.
- 2 Select Boundary 4 only.
- 3 In the **Settings** window for **Boundary Load**, locate the **Force** section.
- 4 Specify the \mathbf{f}_A vector as

0	x
0	y
F0	z

ELECTROSTATICS (ES)

Ground 1

- 1 In the **Physics** toolbar, click  **Boundaries** and choose **Ground**.
- 2 Select Boundary 4 only.

Electric Potential 1

- 1 In the **Physics** toolbar, click  **Boundaries** and choose **Electric Potential**.
- 2 Select Boundary 3 only.

Because of the symmetry, the voltage at the horizontal symmetry plane is half of that applied at the bottom surface.

- 3 In the **Settings** window for **Electric Potential**, locate the **Electric Potential** section.
- 4 In the V_0 text field, type $V_0/2$.

MULTIPHYSICS

Electrostriction 1 (efel)

Study the electrostriction in the material using a fully coupled model.

- 1 In the **Model Builder** window, under **Component 1 (comp1)** > **Multiphysics** click **Electrostriction 1 (efel)**.
- 2 In the **Settings** window for **Electrostriction**, locate the **Coupling Type** section.

3 From the list, choose **Fully coupled**.

Because of a certain symmetry in the material microstructure, you need three parameters to characterize the electrostrictive coupling.

4 Locate the **Electrostriction** section. From the **Material symmetry** list, choose **Cubic crystal**.

5 In the Q_{11} text field, type Q11.

6 In the Q_{12} text field, type Q12.

7 In the Q_{44} text field, type Q44.

MESH I

Mapped I

1 In the **Mesh** toolbar, click  **More Generators** and choose **Mapped**.

2 Select Boundary 4 only.

Size

1 In the **Model Builder** window, click **Size**.

2 In the **Settings** window for **Size**, locate the **Element Size** section.

3 From the **Predefined** list, choose **Coarse**.

Swept I

In the **Mesh** toolbar, click  **Swept**.

Distribution I

1 Right-click **Swept I** and choose **Distribution**.

2 In the **Settings** window for **Distribution**, locate the **Distribution** section.

3 In the **Number of elements** text field, type 2.

4 Click  **Build All**.

STUDY I

Step 1: Stationary

In the first study, no mechanical load is assumed, so the entire excitation is caused by the applied electric field.

1 In the **Model Builder** window, under **Study I** click **Step 1: Stationary**.

2 In the **Settings** window for **Stationary**, click to expand the **Study Extensions** section.

3 Select the **Auxiliary sweep** checkbox.

4 Click  **Add**.

Compute three full cycles for the applied electric potential for each given maximum value.

5 In the table, enter the following settings:

Parameter name	Parameter value list	Parameter unit
t (Time parameter)	range (0, 0.005, 3)	s

6 Click the  **Show More Options** button in the **Model Builder** toolbar.

7 In the **Show More Options** dialog, select **Study** > **Batch and Cluster** in the tree.

8 In the tree, select the checkbox for the node **Study** > **Batch and Cluster**.

9 Click **OK**.

Batch Sweep

1 In the **Study** toolbar, click  **Batch** and choose **Batch Sweep**.

2 In the **Settings** window for **Batch Sweep**, locate the **Study Settings** section.

3 Click  **Add**.

4 In the table, enter the following settings:

Parameter name	Parameter value list	Parameter unit
Vmax (Maximum applied voltage)	600 1000 1600	V

5 Locate the **Batch Settings** section. Find the **Before sweep** subsection. Clear the **Clear meshes** checkbox.

6 Clear the **Clear solutions** checkbox.

7 Locate the **Advanced Settings** section. In the **Number of simultaneous jobs** text field, type 3.

Batch Data

In the **Study** toolbar, click  **Compute**.

RESULTS

Polarization

1 In the **Results** toolbar, click  **ID Plot Group**.

2 In the **Settings** window for **ID Plot Group**, type Polarization in the **Label** text field.

- 3 Locate the **Data** section. From the **Dataset** list, choose **Study 1/ Parametric Solutions 1 (sol2)**.
- 4 Locate the **Grid** section. Select the **Manual spacing** checkbox.
- 5 In the **y spacing** text field, type 0.1.
- 6 Locate the **Legend** section. From the **Position** list, choose **Lower right**.

Point Graph 1

- 1 Right-click **Polarization** and choose **Point Graph**.
- 2 Select Point 1 only.
- 3 In the **Settings** window for **Point Graph**, locate the **y-Axis Data** section.
- 4 In the **Expression** text field, type es.PZ.
- 5 Locate the **x-Axis Data** section. From the **Parameter** list, choose **Expression**.
- 6 In the **Expression** text field, type es.EZ.
- 7 From the **Unit** list, choose **MV/m**.
- 8 Click to expand the **Legends** section. Find the **Include** subsection. Clear the **Point** checkbox.
- 9 Select the **Show legends** checkbox.
- 10 In the **Polarization** toolbar, click  **Plot**.

Electrostriction

- 1 In the **Model Builder** window, right-click **Polarization** and choose **Duplicate**.
- 2 In the **Settings** window for **ID Plot Group**, type Electrostriction in the **Label** text field.
- 3 Locate the **Grid** section. In the **y spacing** text field, type 0.001.

Point Graph 1

- 1 In the **Model Builder** window, expand the **Electrostriction** node, then click **Point Graph 1**.
- 2 In the **Settings** window for **Point Graph**, locate the **y-Axis Data** section.
- 3 In the **Expression** text field, type ef e1.emZZ.
- 4 In the **Electrostriction** toolbar, click  **Plot**.

ADD STUDY

- 1 In the **Home** toolbar, click  **Add Study** to open the **Add Study** window.
- 2 Go to the **Add Study** window.

- 3 Find the **Studies** subsection. In the **Select Study** tree, select **General Studies**.
Add one more stationary study to analyze the mechanical load effect.
- 4 In the **Select Study** tree, select **General Studies > Stationary**.
- 5 Right-click and choose **Add Study**.
- 6 In the **Home** toolbar, click  **Add Study** to close the **Add Study** window.

STUDY 2

Step 1: Stationary

- 1 In the **Settings** window for **Stationary**, locate the **Study Extensions** section.
- 2 Select the **Auxiliary sweep** checkbox.
- 3 Click **+ Add**.
- 4 In the table, enter the following settings:

Parameter name	Parameter value list	Parameter unit
t (Time parameter)	range (0, 0.005, 3)	s

Batch Sweep

- 1 In the **Study** toolbar, click  **Batch** and choose **Batch Sweep**.
- 2 In the **Settings** window for **Batch Sweep**, locate the **Study Settings** section.
- 3 Click **+ Add**.
- 4 In the table, enter the following settings:

Parameter name	Parameter value list	Parameter unit
F0 (Applied mechanical load)	0 -25 -50	MPa

- 5 Locate the **Batch Settings** section. Find the **Before sweep** subsection. Clear the **Clear meshes** checkbox.
- 6 Clear the **Clear solutions** checkbox.
- 7 Locate the **Advanced Settings** section. In the **Number of simultaneous jobs** text field, type 3.

Batch Data

In the **Study** toolbar, click  **Compute**.

RESULTS

Polarization 1

- 1 In the **Model Builder** window, right-click **Polarization** and choose **Duplicate**.
- 2 In the **Settings** window for **ID Plot Group**, locate the **Data** section.
- 3 From the **Dataset** list, choose **Study 2/Parametric Solutions 2 (sol7)**.
- 4 In the **Polarization 1** toolbar, click  **Plot**.

Strain

- 1 In the **Model Builder** window, right-click **Electrostriction** and choose **Duplicate**.
- 2 In the **Settings** window for **ID Plot Group**, type Strain in the **Label** text field.
- 3 Locate the **Data** section. From the **Dataset** list, choose **Study 2/Parametric Solutions 2 (sol7)**.

Point Graph 1

- 1 In the **Model Builder** window, expand the **Strain** node, then click **Point Graph 1**.
- 2 In the **Settings** window for **Point Graph**, locate the **y-Axis Data** section.
- 3 In the **Expression** text field, type `solid.eZZ`.
- 4 In the **Strain** toolbar, click  **Plot**.