



Model created in COMSOL Multiphysics 6.4

Prestressed Micromirror Vibrations: Thermoviscous–Thermoelasticity Coupling

Introduction

This model extends the analysis of the [Prestressed Micromirror](#) by including the losses from the thermoelastic effect and the interaction with the surrounding air. This model also demonstrates the use of the **Thermoviscous Acoustics–Thermoelasticity Boundary** multiphysics coupling.

Model Definition

Physics Interfaces and Couplings

This model uses the following interfaces and multiphysics couplings:

- **Thermoelasticity** — to compute the mechanical losses from irreversible heat transfer driven by thermoelastic effect, which can be particularly important for small structures.
- **Thermoviscous Acoustics, Frequency Domain** — to compute the acoustic variations of pressure, velocity, and temperature in geometries of small dimensions (microacoustics). This interface is used when modeling the response of transducers like microphones, miniature loudspeakers, and MEMS structures.
- **Pressure Acoustics, Frequency Domain** — to compute the pressure variations of the acoustic waves in fluids at quiescent background conditions.
- **Thermal Expansion** multiphysics coupling — to add an internal thermal strain caused by changes in the temperature and account for the corresponding mechanical losses in the heat balance.
- **Thermoviscous Acoustics–Thermoelasticity Boundary** multiphysics coupling — to model thermoviscous losses in acoustic-structure interaction problems in great detail. It captures the effect of a nonideal thermal condition at the fluid-structure interface, which is important in MEMS.
- **Acoustic–Thermoviscous Acoustic Boundary** multiphysics coupling — to couple the **Thermoviscous Acoustics** interface to the **Pressure Acoustics** interface.

Geometry

In addition to the solid domain (for the micromirror), the geometry model includes:

- A box enclosing the original micromirror, assigned to the **Thermoviscous Acoustics, Frequency Domain** interface.
- A half sphere surrounding the box, assigned to the **Pressure Acoustics, Frequency Domain** interface.

Studies

The full model includes both thermoelastic and thermoviscous losses. By disabling the **Thermoviscous Acoustics** interface, the model includes only the thermoelastic effect, that is, only solid losses.

The model analyzes the operation of the micromirror through three studies. The first study computes stationary solutions for the initial normal stress, `sigma_pre`, of 3 GPa as well as the eigenfrequencies of the micromirror.

The second study computes the frequency response using the full model, including thermoviscous and solid losses. The study is done for 50–600 Hz (operating frequency) and for 13,150–13,500 Hz (near resonance).

The third study computes the frequency response using the model with only solid losses. The study is done for 50–600 Hz (frequency of operation) and for 13,150–13,500 Hz (near resonance).

Results and Discussion

Figure 1 shows the fundamental eigenmode of the micromirror, $f_0 = 13,339$ Hz.

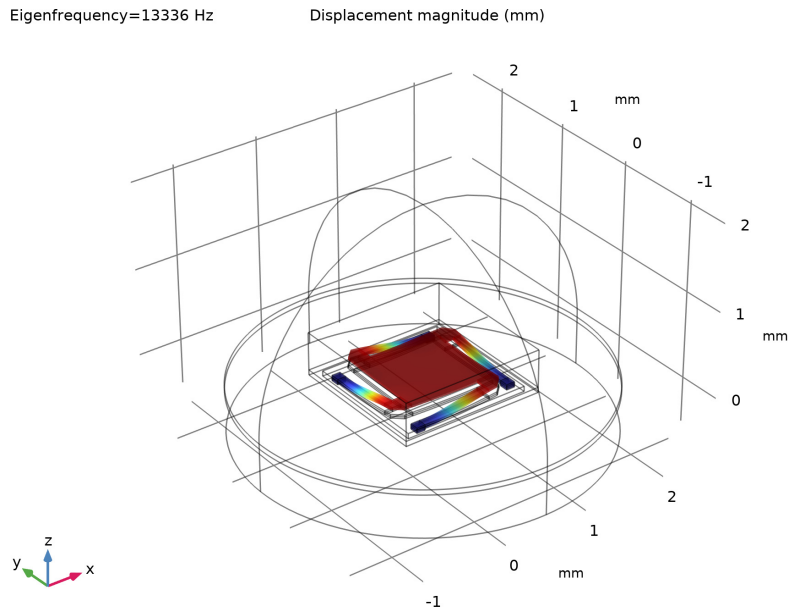

Figure 1: Fundamental eigenmode of the micromirror, initial normal stress = 3 GPa.

Figure 2 contains a surface plot of the displacement for $f = 50$ Hz.

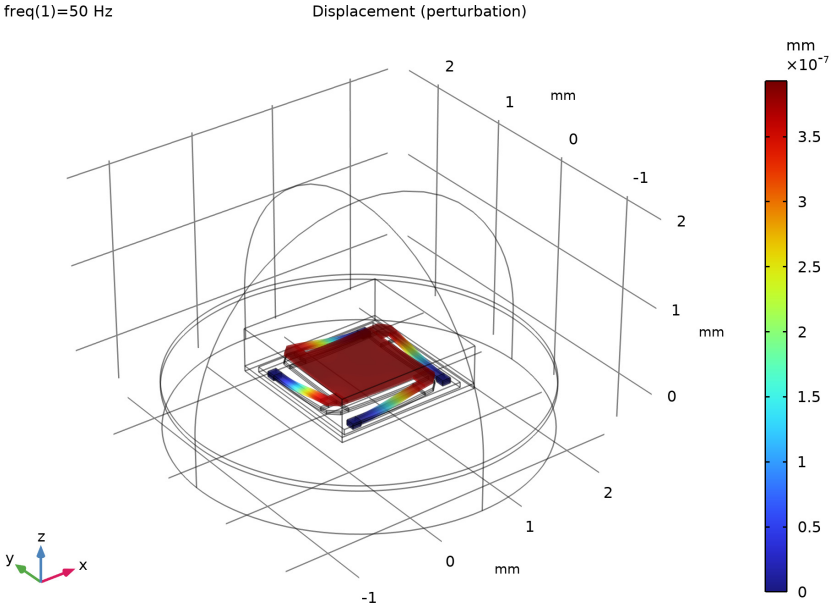

Figure 2: Surface plot of displacement for $f = 50$ Hz.

Figure 3 visualizes the temperature distribution for $f = 50$ Hz using a combination of surface and slice plots.

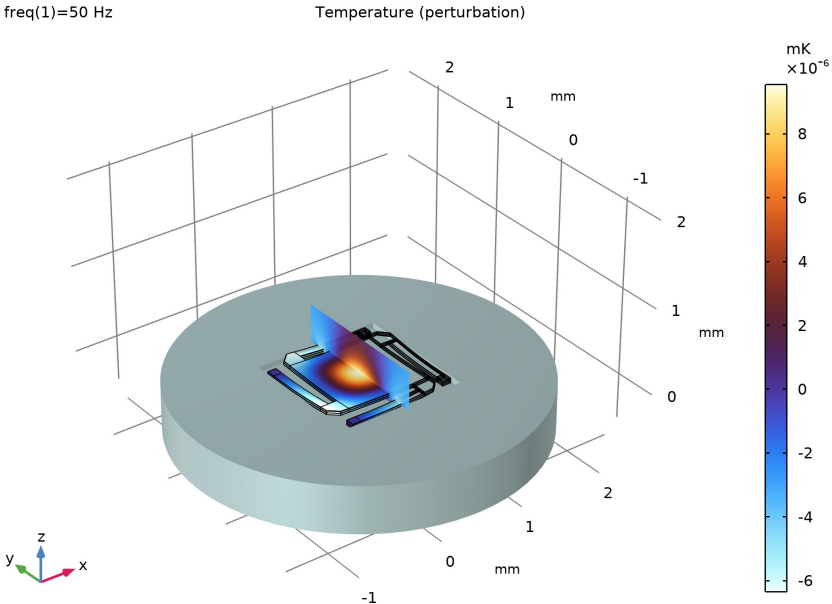

Figure 3: Surface and slice plots of the temperature for $f = 50$ Hz.

Figure 4 shows the acoustic velocity field surrounding the micromirror for $f = 50$ Hz.

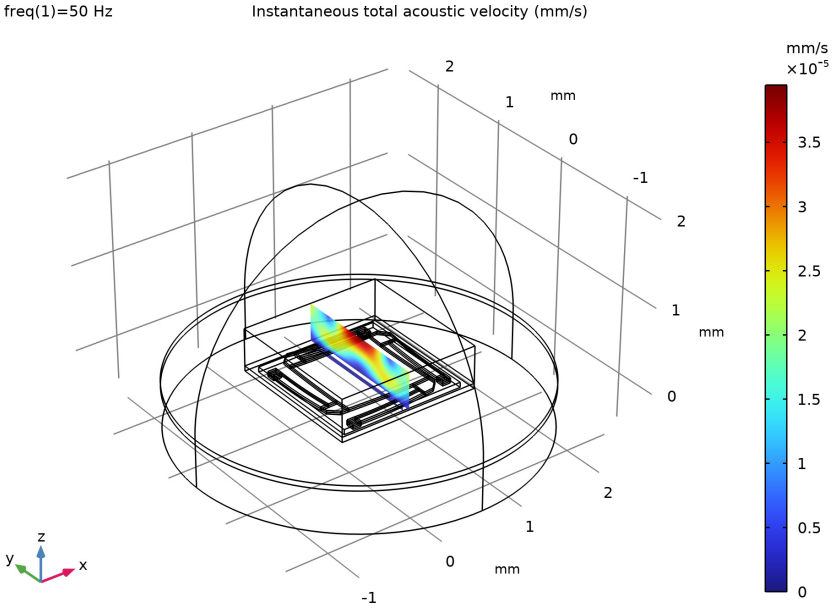

Figure 4: The acoustic velocity field around the micromirror for $f = 50$ Hz.

Figure 5 shows the acoustic pressure field surrounding the micromirror for $f = 50$ Hz

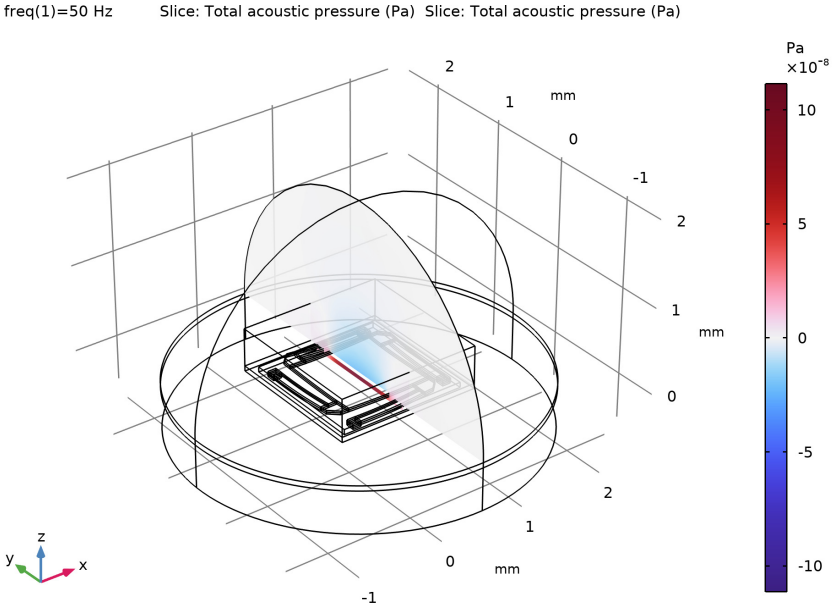

Figure 5: The acoustic pressure field around the micromirror for $f = 50$ Hz.

Figure 6 shows a comparison of the frequency response near the resonance for the full model and for the model with only solid losses.

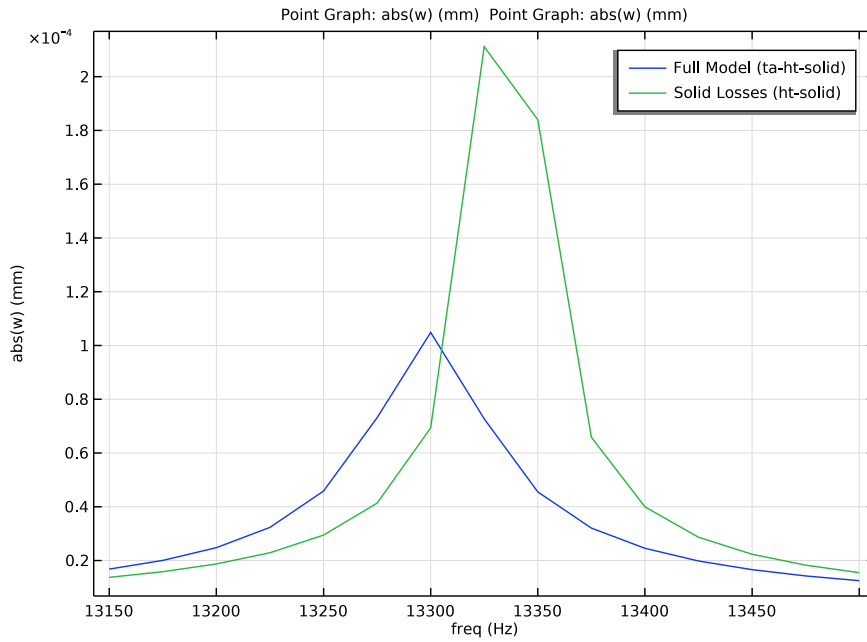

Figure 6: Frequency response around the resonance frequency for the full model and the model with only solid losses.

Figure 7 shows a comparison of the frequency responses in the range 50–600 Hz for the two different models.

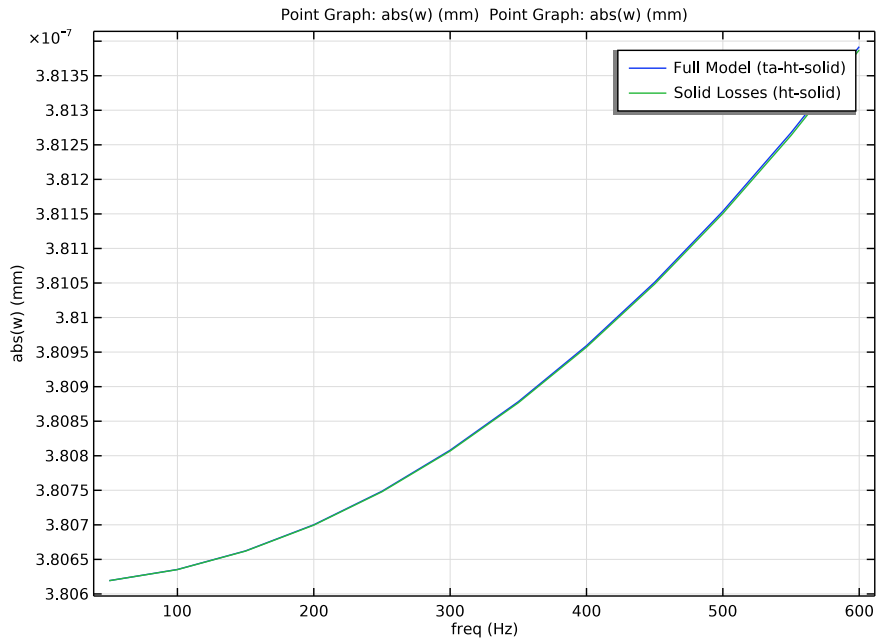

Figure 7: Frequency response around the operating frequencies (50–600 Hz) for the full model and the model with only solid losses.

As expected, near the resonance, the vibration frequency and amplitude are less for the full model than for the model with only solid losses. Around operating frequencies in the range 50–600 Hz, however, the difference in losses is negligible.

Reference

1. G. Kovacs, *Micromachined Transducers Sourcebook*, WCM McGraw Hill, 1998.

Application Library path: MEMS_Module/Actuators/
micromirror_prestressed_vibration

Modeling Instructions



Start by creating a new 3D model.

From the **File** menu, choose **New**.

NEW

In the **New** window, click  **Model Wizard**.

MODEL WIZARD

- 1 In the **Model Wizard** window, click  **3D**.
- 2 In the **Select Physics** tree, select **Structural Mechanics > Thermal–Structure Interaction > Thermoelasticity**.
- 3 Click **Add**.
- 4 In the **Select Physics** tree, select **Acoustics > Thermoviscous Acoustics > Thermoviscous Acoustics, Frequency Domain (ta)**.
- 5 Click **Add**.
- 6 In the **Select Physics** tree, select **Acoustics > Pressure Acoustics > Pressure Acoustics, Frequency Domain (acpr)**.
- 7 Click **Add**.
- 8 Click  **Study**.
- 9 In the **Select Study** tree, select **Preset Studies for Selected Physics Interfaces > Solid Mechanics > Eigenfrequency, Prestressed**.
- 10 Click  **Done**.

MULTIPHYSICS

Acoustic–Thermoviscous Acoustic Boundary 1 (atb1)

In the **Physics** toolbar, click  **Multiphysics Couplings** and choose **Boundary > Acoustic–Thermoviscous Acoustic Boundary**.

Thermoviscous Acoustic–Thermoelasticity Boundary 1 (tatb1)

In the **Physics** toolbar, click  **Multiphysics Couplings** and choose **Boundary > Thermoviscous Acoustic–Thermoelasticity Boundary**.

Define and enter the values of the global parameters.

GLOBAL DEFINITIONS

Parameters 1

- 1 In the **Model Builder** window, under **Global Definitions** click **Parameters 1**.
- 2 In the **Settings** window for **Parameters**, locate the **Parameters** section.
- 3 In the table, enter the following settings:

Name	Expression	Value	Description
sigma_pre	3[GPa]	3E9 Pa	Initial normal stress
fc	13400[Hz]	13400 Hz	Typical frequency
dvisc	$0.22[\text{mm}] * \sqrt{100[\text{Hz}] / \text{fc}}$	1.9005E-5 m	Viscous boundary layer thickness at fc

Build the geometry of the micromirror.

GEOMETRY 1

Set the geometry unit to mm for convenience.

- 1 In the **Model Builder** window, under **Component 1 (comp1)** click **Geometry 1**.
- 2 In the **Settings** window for **Geometry**, locate the **Units** section.
- 3 From the **Length unit** list, choose **mm**.

Work Plane 1 (wp1)

In the **Geometry** toolbar, click  **Work Plane**.

Work Plane 1 (wp1) > Plane Geometry

In the **Model Builder** window, click **Plane Geometry**.

Work Plane 1 (wp1) > Square 1 (sq1)

In the **Work Plane** toolbar, click  **Square**.

Work Plane 1 (wp1) > Square 2 (sq2)

- 1 In the **Work Plane** toolbar, click  **Square**.
- 2 In the **Settings** window for **Square**, locate the **Size** section.
- 3 In the **Side length** text field, type 0.2.
- 4 Locate the **Position** section. In the **yw** text field, type 1.

Work Plane 1 (wp1) > Chamfer 1 (cha1)

1 In the **Work Plane** toolbar, click  **Chamfer**.

- 2 Click the  **Zoom Extents** button in the **Graphics** toolbar.
- 3 On the object **sq2**, select Point 4 only.
- 4 In the **Settings** window for **Chamfer**, locate the **Distance** section.
- 5 In the **Distance from vertex** text field, type 0.1.

Work Plane 1 (wp1) > Rectangle 1 (r1)

- 1 In the **Work Plane** toolbar, click  **Rectangle**.
- 2 In the **Settings** window for **Rectangle**, locate the **Size and Shape** section.
- 3 In the **Width** text field, type 0.9.
- 4 In the **Height** text field, type 0.1.
- 5 Locate the **Position** section. In the **xw** text field, type 0.2.
- 6 In the **yw** text field, type 1.1.

Work Plane 1 (wp1) > Square 3 (sq3)

- 1 In the **Work Plane** toolbar, click  **Square**.
- 2 In the **Settings** window for **Square**, locate the **Size** section.
- 3 In the **Side length** text field, type 0.1.
- 4 Locate the **Position** section. In the **xw** text field, type 1.
- 5 In the **yw** text field, type 1.1.

Work Plane 1 (wp1) > Rotate 1 (rot1)

- 1 In the **Work Plane** toolbar, click  **Transforms** and choose **Rotate**.
- 2 Select the objects **cha1**, **r1**, and **sq3** only.
- 3 In the **Settings** window for **Rotate**, locate the **Rotation** section.
- 4 In the **Angle** text field, type range (90,90,360).
- 5 Locate the **Center of Rotation** section. In the **xw** text field, type 0.5.
- 6 In the **yw** text field, type 0.5.

Extrude 1 (ext1)

- 1 In the **Model Builder** window, right-click **Geometry 1** and choose **Extrude**.
- 2 In the **Settings** window for **Extrude**, locate the **Distances** section.
- 3 In the table, enter the following settings:

Distances (mm)
0.02
0.04

Extrude 2 (ext2)

- 1 In the **Geometry** toolbar, click  **Extrude**.
- 2 In the **Settings** window for **Extrude**, locate the **General** section.
- 3 From the **Extrude from** list, choose **Faces**.
- 4 On the object **ext1**, select Boundaries 17, 26, 111, and 120 only.
- 5 Locate the **Distances** section. In the table, enter the following settings:

Distances (mm)
0.02

Block 1 (blk1)

- 1 In the **Geometry** toolbar, click  **Block**.
- 2 In the **Settings** window for **Block**, locate the **Size and Shape** section.
- 3 In the **Width** text field, type 1.45.
- 4 In the **Depth** text field, type 1.45.
- 5 In the **Height** text field, type 0.06.
- 6 Locate the **Position** section. In the **x** text field, type -0.225.
- 7 In the **y** text field, type -0.225.
- 8 In the **z** text field, type -0.02.

Add a cylindrical base for the micromirror.

Cylinder 1 (cyl1)



- 1 In the **Geometry** toolbar, click  **Cylinder**.
- 2 In the **Settings** window for **Cylinder**, locate the **Size and Shape** section.
- 3 In the **Radius** text field, type 2.
- 4 In the **Height** text field, type 0.5.
- 5 Locate the **Position** section. In the **x** text field, type 0.5.
- 6 In the **y** text field, type 0.5.
- 7 In the **z** text field, type -0.52.

Cylinder 2 (cyl2)

- 1 In the **Geometry** toolbar, click  **Cylinder**.
- 2 In the **Settings** window for **Cylinder**, locate the **Size and Shape** section.
- 3 In the **Radius** text field, type 2.
- 4 In the **Height** text field, type 0.06.

- 5 Locate the **Position** section. In the **x** text field, type 0.5.
- 6 In the **y** text field, type 0.5.
- 7 In the **z** text field, type -0.02.

Difference 1 (dif1)

- 1 In the **Geometry** toolbar, click  **Booleans and Partitions** and choose **Difference**.
- 2 Click the  **Zoom Extents** button in the **Graphics** toolbar.
- 3 Select the object **cyl2** only.
- 4 In the **Settings** window for **Difference**, locate the **Difference** section.
- 5 Click to select the  **Activate Selection** toggle button for **Objects to subtract**.
- 6 Select the object **blk1** only.

Add a box for the thermoviscous acoustics domain.

Block 2 (blk2)

- 1 In the **Geometry** toolbar, click  **Block**.
- 2 In the **Settings** window for **Block**, locate the **Size and Shape** section.
- 3 In the **Width** text field, type 1.65.
- 4 In the **Depth** text field, type 1.65.
- 5 In the **Height** text field, type .5.
- 6 Locate the **Position** section. In the **x** text field, type -0.325.
- 7 In the **y** text field, type -0.325.
- 8 In the **z** text field, type -0.02.

Add a sphere for the pressure acoustics domain.

Sphere 1 (sph1)

- 1 In the **Geometry** toolbar, click  **Sphere**.
- 2 In the **Settings** window for **Sphere**, locate the **Size** section.
- 3 In the **Radius** text field, type 2.
- 4 Locate the **Position** section. In the **x** text field, type 0.5.
- 5 In the **y** text field, type 0.5.
- 6 In the **z** text field, type 0.04.

Work Plane 2 (wp2)

- 1 In the **Geometry** toolbar, click  **Work Plane**.
- 2 In the **Settings** window for **Work Plane**, locate the **Plane Definition** section.

3 In the **z-coordinate** text field, type 0.04.

Partition Objects 1 (par1)

- 1 In the **Geometry** toolbar, click  **Booleans and Partitions** and choose **Partition Objects**.
- 2 Select the object **sph1** only.
- 3 In the **Settings** window for **Partition Objects**, locate the **Partition Objects** section.
- 4 From the **Partition with** list, choose **Work plane**.



Delete Entities 1 (del1)

- 1 Right-click **Geometry 1** and choose **Delete Entities**.
- 2 In the **Settings** window for **Delete Entities**, locate the **Entities or Objects to Delete** section.
- 3 From the **Geometric entity level** list, choose **Domain**.
- 4 On the object **par1**, select Domain 1 only.



Define selections to use when assigning material properties and boundary conditions.

DEFINITIONS



Air TA

- 1 In the **Definitions** toolbar, click  **Explicit**.
- 2 In the **Settings** window for **Explicit**, type Air TA in the **Label** text field.
- 3 Locate the **Input Entities** section. Click  **Paste Selection**.
- 4 In the **Paste Selection** dialog, type 5 6 in the **Selection** text field.
- 5 Click **OK**.

Air ACPR

- 1 In the **Definitions** toolbar, click  **Explicit**.
- 2 In the **Settings** window for **Explicit**, type Air ACPR in the **Label** text field.
- 3 Locate the **Input Entities** section. Click  **Paste Selection**.
- 4 In the **Paste Selection** dialog, type 3 in the **Selection** text field.
- 5 Click **OK**.

Substrate

- 1 In the **Definitions** toolbar, click  **Explicit**.
- 2 In the **Settings** window for **Explicit**, type Substrate in the **Label** text field.
- 3 Locate the **Input Entities** section. Click  **Paste Selection**.

4 In the **Paste Selection** dialog, type 1 2 4 in the **Selection** text field.

5 Click **OK**.

Solid

1 In the **Definitions** toolbar, click  **Explicit**.

2 In the **Settings** window for **Explicit**, type Solid in the **Label** text field.

3 Locate the **Input Entities** section. Click  **Paste Selection**.

4 In the **Paste Selection** dialog, type 7-36 in the **Selection** text field.

5 Click **OK**.

Solid Aluminum

1 In the **Definitions** toolbar, click  **Explicit**.

2 In the **Settings** window for **Explicit**, type Solid Aluminum in the **Label** text field.

3 Locate the **Input Entities** section. Click  **Paste Selection**.

4 In the **Paste Selection** dialog, type 9-18, 23, 24, 29-36 in the **Selection** text field.

5 Click **OK**.

Solid Steel

1 In the **Definitions** toolbar, click  **Explicit**.

2 In the **Settings** window for **Explicit**, type Solid Steel in the **Label** text field.

3 Locate the **Input Entities** section. Click  **Paste Selection**.

4 In the **Paste Selection** dialog, type 7, 8, 19-22, 25-28 in the **Selection** text field.

5 Click **OK**.

Solid-TA

1 In the **Definitions** toolbar, click  **Explicit**.

2 In the **Settings** window for **Explicit**, type Solid-TA in the **Label** text field.



3 Locate the **Input Entities** section. From the **Geometric entity level** list, choose **Boundary**.

4 Click  **Paste Selection**.

5 In the **Paste Selection** dialog, type 24-28, 30, 31, 33, 34, 37-39, 41, 44, 47-52, 54, 55, 57, 58, 60-73, 75, 76, 78, 80-82, 84, 85, 87, 89-92, 94, 95, 98-106, 108, 109, 111, 113-115, 123, 124, 126, 128-130, 133-138, 140, 141, 143, 145-149, 152, 155, 157-162, 164, 165, 167, 168, 170-172, 174, 175, 178, 181-192 in the **Selection** text field.

6 Click **OK**.

Air



- 1 In the **Definitions** toolbar, click  **Union**.
- 2 In the **Settings** window for **Union**, type **Air** in the **Label** text field.
- 3 Locate the **Input Entities** section. Under **Selections to add**, click  **Add**.
- 4 In the **Add** dialog, in the **Selections to add** list, choose **Air TA** and **Air ACPR**.
- 5 Click **OK**.

Participation Factors 1 (mpf1)

In the **Definitions** toolbar, click  **Physics Utilities** and choose **Participation Factors**.

Add materials from the material library and assign to the respective domains.

ADD MATERIAL

- 1 In the **Materials** toolbar, click  **Add Material** to open the **Add Material** window.
- 2 Go to the **Add Material** window.
- 3 In the tree, select **Built-in > Aluminum**.
- 4 Click the **Add to Component** button in the window toolbar.
- 5 In the tree, select **Built-in > Structural steel**.
- 6 Click the **Add to Component** button in the window toolbar.
- 7 In the tree, select **Built-in > Air**.
- 8 Click the **Add to Component** button in the window toolbar.
- 9 In the **Materials** toolbar, click  **Add Material** to close the **Add Material** window.

MATERIALS

Aluminum (mat1)

- 1 In the **Settings** window for **Material**, locate the **Geometric Entity Selection** section.
- 2 From the **Selection** list, choose **Solid Aluminum**.

Structural steel (mat2)

- 1 In the **Model Builder** window, click **Structural steel (mat2)**.
- 2 In the **Settings** window for **Material**, locate the **Geometric Entity Selection** section.
- 3 From the **Selection** list, choose **Solid Steel**.

Air (mat3)



- 1 In the **Model Builder** window, click **Air (mat3)**.
- 2 In the **Settings** window for **Material**, locate the **Geometric Entity Selection** section.

3 From the **Selection** list, choose **Air**.

Define the Deforming Domain.

COMPONENT 1 (COMP1)

Deforming Domain 1



- 1 In the **Physics** toolbar, click  **Moving Mesh** and choose **Free Deformation**.
- 2 In the **Settings** window for **Deforming Domain**, locate the **Domain Selection** section.
- 3 Click  **Clear Selection**.
- 4 Click  **Paste Selection**.
- 5 In the **Paste Selection** dialog, type 5 6 in the **Selection** text field.
- 6 Click **OK**.
- 7 In the **Settings** window for **Deforming Domain**, locate the **Smoothing** section.
- 8 From the **Mesh smoothing type** list, choose **Hyperelastic**.

SOLID MECHANICS (SOLID)

Linear Elastic Material 1

In the **Model Builder** window, under **Component 1 (comp1) > Solid Mechanics (solid)** click **Linear Elastic Material 1**.

Initial Stress and Strain 1



- 1 In the **Physics** toolbar, click  **Attributes** and choose **Initial Stress and Strain**.
- 2 In the **Settings** window for **Initial Stress and Strain**, locate the **Domain Selection** section.
- 3 From the **Selection** list, choose **Manual**.
- 4 Click  **Clear Selection**.
- 5 Click  **Paste Selection**.
- 6 In the **Paste Selection** dialog, type 10 18 24 36 in the **Selection** text field.
- 7 Click **OK**.
- 8 In the **Settings** window for **Initial Stress and Strain**, locate the **Initial Stress and Strain** section.
- 9 Specify the S_0 matrix as

sigma_pre	0	0
0	sigma_pre	0
0	0	0

Linear Elastic Material 1



In the **Model Builder** window, click **Linear Elastic Material 1**.

Initial Stress and Strain 2



- 1 In the **Physics** toolbar, click  **Attributes** and choose **Initial Stress and Strain**.
- 2 In the **Settings** window for **Initial Stress and Strain**, locate the **Domain Selection** section.
- 3 Click  **Clear Selection**.
- 4 Click  **Paste Selection**.
- 5 In the **Paste Selection** dialog, type 9 17 23 35 in the **Selection** text field.
- 6 Click **OK**.
- 7 In the **Settings** window for **Initial Stress and Strain**, locate the **Initial Stress and Strain** section.
- 8 Specify the S_0 matrix as

-sigma_pre	0	0
0	-sigma_pre	0
0	0	0

Fixed Constraint 1

- 1 In the **Physics** toolbar, click  **Boundaries** and choose **Fixed Constraint**.
- 2 In the **Settings** window for **Fixed Constraint**, locate the **Boundary Selection** section.
- 3 Click  **Paste Selection**.
- 4 In the **Paste Selection** dialog, type 40 53 150 163 in the **Selection** text field.
- 5 Click **OK**.

Boundary Load 1

- 1 In the **Physics** toolbar, click  **Boundaries** and choose **Boundary Load**.
- 2 In the **Settings** window for **Boundary Load**, locate the **Boundary Selection** section.
- 3 Click  **Paste Selection**.
- 4 In the **Paste Selection** dialog, type 85 in the **Selection** text field.
- 5 Click **OK**.
- 6 In the **Settings** window for **Boundary Load**, locate the **Force** section.
- 7 Specify the \mathbf{f}_A vector as

0	x
---	---



0	y
linper(1)	z

- 8 In the **Model Builder** window, click **Solid Mechanics (solid)**.
- 9 In the **Settings** window for **Solid Mechanics**, locate the **Domain Selection** section.
- 10 From the **Selection** list, choose **Solid**.



HEAT TRANSFER IN SOLIDS (HT)

- 1 In the **Model Builder** window, under **Component 1 (comp1)** click **Heat Transfer in Solids (ht)**.
- 2 In the **Settings** window for **Heat Transfer in Solids**, locate the **Domain Selection** section.
- 3 From the **Selection** list, choose **Solid**.



Temperature 1

- 1 In the **Physics** toolbar, click  **Boundaries** and choose **Temperature**.
- 2 In the **Settings** window for **Temperature**, locate the **Boundary Selection** section.
- 3 Click  **Paste Selection**.
- 4 In the **Paste Selection** dialog, type 40 53 150 163 in the **Selection** text field.
- 5 Click **OK**.

THERMOVISCOUS ACOUSTICS, FREQUENCY DOMAIN (TA)

- 1 In the **Model Builder** window, under **Component 1 (comp1)** click **Thermoviscous Acoustics, Frequency Domain (ta)**.
- 2 In the **Settings** window for **Thermoviscous Acoustics, Frequency Domain**, locate the **Domain Selection** section.
- 3 From the **Selection** list, choose **Manual**.
- 4 Click  **Clear Selection**.
- 5 Click  **Paste Selection**.
- 6 In the **Paste Selection** dialog, type 5 6 in the **Selection** text field.
- 7 Click **OK**.

Wall 2



- 1 In the **Physics** toolbar, click  **Boundaries** and choose **Wall**.
- 2 In the **Settings** window for **Wall**, locate the **Boundary Selection** section.
- 3 Click  **Paste Selection**.
- 4 In the **Paste Selection** dialog, type 15 in the **Selection** text field.

- 5 Click **OK**.
- 6 In the **Settings** window for **Wall**, locate the **Mechanical** section.
- 7 From the **Mechanical condition** list, choose **Slip (perfect)**.
- 8 Locate the **Thermal** section. From the **Thermal condition** list, choose **Adiabatic**.

PRESSURE ACOUSTICS, FREQUENCY DOMAIN (ACPR)

- 1 In the **Model Builder** window, under **Component 1 (comp1)** click **Pressure Acoustics, Frequency Domain (acpr)**.
- 2 In the **Settings** window for **Pressure Acoustics, Frequency Domain**, locate the **Domain Selection** section.
- 3 From the **Selection** list, choose **Air ACPR**.
- 4 Click the  **Show More Options** button in the **Model Builder** toolbar.
- 5 In the **Show More Options** dialog, click **Cancel**.

Perfectly Matched Boundary 1

- 1 In the **Physics** toolbar, click  **Boundaries** and choose **Perfectly Matched Boundary**.
- 2 In the **Settings** window for **Perfectly Matched Boundary**, locate the **Boundary Selection** section.
- 3 Click  **Paste Selection**.
- 4 In the **Paste Selection** dialog, type 7 9 118 119 in the **Selection** text field.
- 5 Click **OK**.
- 6 In the **Settings** window for **Perfectly Matched Boundary**, locate the **Geometry** section.
- 7 From the **Attenuation direction** list, choose **Normal**.

MULTIPHYSICS

Thermal Expansion 1 (te1)

- 1 In the **Model Builder** window, under **Component 1 (comp1) > Multiphysics** click **Thermal Expansion 1 (te1)**.
- 2 In the **Settings** window for **Thermal Expansion**, locate the **Heat Sources** section.
- 3 Select the **Mechanical losses** checkbox.
- 4 Click the  **Transparency** button in the **Graphics** toolbar.

Acoustic–Thermoviscous Acoustic Boundary 1 (atb1)

- 1 In the **Model Builder** window, click **Acoustic–Thermoviscous Acoustic Boundary 1 (atb1)**.

- 2 In the **Settings** window for **Acoustic–Thermoviscous Acoustic Boundary**, locate the **Boundary Selection** section.
- 3 From the **Selection** list, choose **All boundaries**.



Thermoviscous Acoustic–Thermoelasticity Boundary 1 (tatb1)

- 1 In the **Model Builder** window, click **Thermoviscous Acoustic–Thermoelasticity Boundary 1 (tatb1)**.
- 2 In the **Settings** window for **Thermoviscous Acoustic–Thermoelasticity Boundary**, locate the **Boundary Selection** section.
- 3 From the **Selection** list, choose **Solid-TA**.



Define the mesh for the model.

MESH 1

Mapped 1

- 1 In the **Mesh** toolbar, click  **More Generators** and choose **Mapped**.
- 2 In the **Settings** window for **Mapped**, locate the **Boundary Selection** section.
- 3 Click  **Paste Selection**.
- 4 In the **Paste Selection** dialog, type 30, 37, 47, 60, 80, 89, 98, 113, 128, 145, 157, 170, 178 in the **Selection** text field.
- 5 Click **OK**.

Distribution 1

- 1 Right-click **Mapped 1** and choose **Distribution**.
- 2 In the **Settings** window for **Distribution**, locate the **Edge Selection** section.
- 3 Click  **Copy Selection**.
- 4 Click  **Paste Selection**.
- 5 In the **Paste Selection** dialog, type 45, 115, 129, 134, 160, 173, 219, 304 in the **Selection** text field.
- 6 Click **OK**.
- 7 In the **Settings** window for **Distribution**, locate the **Distribution** section.
- 8 In the **Number of elements** text field, type 12.

Distribution 2

- 1 In the **Model Builder** window, right-click **Mapped 1** and choose **Distribution**.
- 2 In the **Settings** window for **Distribution**, locate the **Edge Selection** section.

- 3 Click  **Paste Selection**.
- 4 In the **Paste Selection** dialog, type 56, 64, 74, 75, 95, 159, 199, 227, 243, 261, 288, 298 in the **Selection** text field.
- 5 Click **OK**.
- 6 In the **Settings** window for **Distribution**, locate the **Distribution** section.
- 7 In the **Number of elements** text field, type 3.

Distribution 3

- 1 Right-click **Mapped I** and choose **Distribution**.
- 2 In the **Settings** window for **Distribution**, locate the **Edge Selection** section.
- 3 Click  **Paste Selection**.
- 4 In the **Paste Selection** dialog, type 37 152 194 309 in the **Selection** text field.
- 5 Click **OK**.
- 6 In the **Settings** window for **Distribution**, locate the **Distribution** section.
- 7 In the **Number of elements** text field, type 6.



Swept I

- 1 In the **Mesh** toolbar, click  **Swept**.
- 2 In the **Settings** window for **Swept**, locate the **Domain Selection** section.
- 3 From the **Geometric entity level** list, choose **Domain**.
- 4 From the **Selection** list, choose **Solid**.

Distribution I

- 1 Right-click **Swept I** and choose **Distribution**.
- 2 In the **Settings** window for **Distribution**, locate the **Domain Selection** section.
- 3 Click  **Clear Selection**.
- 4 Locate the **Distribution** section. In the **Number of elements** text field, type 2.

Free Tetrahedral I

- 1 In the **Mesh** toolbar, click  **Free Tetrahedral**.
- 2 In the **Settings** window for **Free Tetrahedral**, locate the **Domain Selection** section.
- 3 From the **Geometric entity level** list, choose **Domain**.
- 4 Click  **Paste Selection**.
- 5 In the **Paste Selection** dialog, type 6 in the **Selection** text field.
- 6 Click **OK**.

Size 1

- 1 Right-click **Free Tetrahedral 1** and choose **Size**.
- 2 In the **Settings** window for **Size**, locate the **Element Size** section.
- 3 Click the **Custom** button.
- 4 Locate the **Geometric Entity Selection** section. From the **Geometric entity level** list, choose **Boundary**.
- 5 Click  **Paste Selection**.
- 6 In the **Paste Selection** dialog, type 19 20 23 193 in the **Selection** text field.
- 7 Click **OK**.
- 8 In the **Settings** window for **Size**, locate the **Element Size Parameters** section.
- 9 Select the **Maximum element size** checkbox. In the associated text field, type 0.04.



Free Tetrahedral 2

In the **Mesh** toolbar, click  **Free Tetrahedral**.

Size 1

- 1 Right-click **Free Tetrahedral 2** and choose **Size**.
- 2 In the **Settings** window for **Size**, locate the **Element Size** section.
- 3 Click the **Custom** button.
- 4 Locate the **Element Size Parameters** section.
- 5 Select the **Maximum element size** checkbox. In the associated text field, type 0.8.

Boundary Layers 1

- 1 In the **Mesh** toolbar, click  **Boundary Layers**.
- 2 In the **Settings** window for **Boundary Layers**, locate the **Geometric Entity Selection** section.
- 3 From the **Geometric entity level** list, choose **Domain**.
- 4 Click  **Paste Selection**.
- 5 In the **Paste Selection** dialog, type 5 6 in the **Selection** text field.
- 6 Click **OK**.
- 7 In the **Settings** window for **Boundary Layers**, click to expand the **Corner Settings** section.
- 8 From the **Handling of sharp edges** list, choose **No special handling**.

Boundary Layer Properties

- 1 In the **Model Builder** window, click **Boundary Layer Properties**.

- 2 In the **Settings** window for **Boundary Layer Properties**, locate the **Boundary Selection** section.
- 3 From the **Selection** list, choose **Solid-TA**.
- 4 Locate the **Layers** section. In the **Number of layers** text field, type 3.
- 5 From the **Thickness specification** list, choose **All layers**.
- 6 In the **Total thickness** text field, type d_{visc} .

Size

- 1 In the **Model Builder** window, under **Component 1 (comp1) > Mesh 1** click **Size**.
- 2 In the **Settings** window for **Size**, locate the **Element Size** section.
- 3 Click the **Custom** button.
- 4 Locate the **Element Size Parameters** section. In the **Maximum element size** text field, type 1.
- 5 In the **Minimum element size** text field, type 0.01.
- 6 In the **Model Builder** window, right-click **Mesh 1** and choose **Build All**.

Add a study to compute the eigenfrequencies of the solid structure.

STUDY 1 - STRUCTURAL MODES (LOSSLESS)

- 1 In the **Model Builder** window, click **Study 1**.
- 2 In the **Settings** window for **Study**, type Study 1 - Structural Modes (lossless) in the **Label** text field.
- 3 Locate the **Study Settings** section. Clear the **Generate default plots** checkbox.

Step 1: Stationary

- 1 In the **Model Builder** window, under **Study 1 - Structural Modes (lossless)** click **Step 1: Stationary**.
- 2 In the **Settings** window for **Stationary**, locate the **Physics and Variables Selection** section.
- 3 In the **Solve for** column of the table, under **Component 1 (comp1)**, clear the checkboxes for **Heat Transfer in Solids (ht)** and **Moving Mesh**.
- 4 In the **Solve for** column of the table, under **Component 1 (comp1) > Multiphysics**, clear the checkbox for **Thermal Expansion 1 (te1)**.
- 5 Right-click **Study 1 - Structural Modes (lossless) > Step 1: Stationary** and choose **Compute Selected Step**.



Step 2: Eigenfrequency

- 1 In the **Model Builder** window, click **Step 2: Eigenfrequency**.

- 2 In the **Settings** window for **Eigenfrequency**, locate the **Study Settings** section.
- 3 Select the **Desired number of eigenfrequencies** checkbox. In the associated text field, type 4.
- 4 In the **Search for eigenfrequencies around shift** text field, type 8000[Hz].
- 5 From the **Search method around shift** list, choose **Larger real part**.
- 6 Locate the **Physics and Variables Selection** section. In the **Solve for** column of the table, under **Component 1 (comp1)**, clear the checkboxes for **Heat Transfer in Solids (ht)**, **Thermoviscous Acoustics, Frequency Domain (ta)**, **Pressure Acoustics, Frequency Domain (acpr)**, and **Moving Mesh**.
- 7 In the **Solve for** column of the table, under **Component 1 (comp1) > Multiphysics**, clear the checkboxes for **Thermal Expansion 1 (te1)**, **Acoustic–Thermoviscous Acoustic Boundary 1 (atb1)**, and **Thermoviscous Acoustic–Thermoelasticity Boundary 1 (tatb1)**.
- 8 Right-click **Step 2: Eigenfrequency** and choose **Compute Selected Step**.

Add a study to compute the frequency response of the full model.

ADD STUDY

- 1 In the **Home** toolbar, click  **Add Study** to open the **Add Study** window.
- 2 Go to the **Add Study** window.
- 3 Find the **Studies** subsection. In the **Select Study** tree, select **Preset Studies for Selected Physics Interfaces > Solid Mechanics > Frequency Domain, Prestressed**.
- 4 Click the **Add Study** button in the window toolbar.
- 5 In the **Home** toolbar, click  **Add Study** to close the **Add Study** window.

STUDY 2 - FREQUENCY RESPONSE: FULL MODEL (TA-HT-SOLID)

- 1 In the **Settings** window for **Study**, type Study 2 - Frequency Response: Full Model (ta-ht-solid) in the **Label** text field.
- 2 Locate the **Study Settings** section. Clear the **Generate default plots** checkbox.

Step 1: Stationary

- 1 In the **Model Builder** window, under **Study 2 - Frequency Response: Full Model (ta-ht-solid)** click **Step 1: Stationary**.
- 2 In the **Settings** window for **Stationary**, click to expand the **Study Extensions** section.
- 3 Select the **Auxiliary sweep** checkbox.

4 Click  **Add**.

5 In the table, enter the following settings:

Parameter name	Parameter value list	Parameter unit
sigma_pre (Initial normal stress)	range(1, 1, 3)	GPa

6 Right-click **Study 2 - Frequency Response: Full Model (ta-ht-solid)** > **Step 1: Stationary** and choose **Compute Selected Step**.

Step 2: Frequency-Domain Perturbation

1 In the **Model Builder** window, click **Step 2: Frequency-Domain Perturbation**.

2 In the **Settings** window for **Frequency-Domain Perturbation**, locate the **Study Settings** section.

3 In the **Frequencies** text field, type range(50, 50, 600) range(13150, 25, 13500).

4 From the **Reuse solution from previous step** list, choose **No**.

5 Locate the **Values of Linearization Point** section. From the **Settings** list, choose **User controlled**.

6 From the **Parameter value (sigma_pre (GPa))** list, choose **3 GPa**.

7 Locate the **Physics and Variables Selection** section. In the **Solve for** column of the table, under **Component 1 (comp1)**, clear the checkbox for **Moving Mesh**.

8 Click to expand the **Values of Dependent Variables** section. Find the **Values of variables not solved for** subsection. From the **Settings** list, choose **User controlled**.

9 From the **Use** list, choose **Solution Store 2 (sol4)**.

10 From the **Parameter value (sigma_pre (GPa))** list, choose **3 GPa**.

11 Right-click **Step 2: Frequency-Domain Perturbation** and choose **Compute Selected Step**.

Add a study to compute the frequency response of the model with only solid losses.

ADD STUDY

1 In the **Study** toolbar, click  **Add Study** to open the **Add Study** window.

2 Go to the **Add Study** window.

3 Find the **Studies** subsection. In the **Select Study** tree, select **Preset Studies for Selected Physics Interfaces > Solid Mechanics > Frequency Domain, Prestressed**.

4 Click the **Add Study** button in the window toolbar.

5 In the **Study** toolbar, click  **Add Study** to close the **Add Study** window.

STUDY 3 - FREQUENCY RESPONSE: SOLID LOSSES (HT-SOLID)

1 In the **Settings** window for **Study**, type Study 3 - Frequency Response: Solid Losses (ht-solid) in the **Label** text field.

2 Locate the **Study Settings** section. Clear the **Generate default plots** checkbox.

Step 1: Stationary

1 In the **Model Builder** window, under **Study 3 - Frequency Response: Solid Losses (ht-solid)** click **Step 1: Stationary**.

2 In the **Settings** window for **Stationary**, locate the **Physics and Variables Selection** section.

3 In the **Solve for** column of the table, under **Component 1 (comp1)**, clear the checkbox for **Moving Mesh**.

4 Locate the **Study Extensions** section. Select the **Auxiliary sweep** checkbox.

5 Click **+ Add**.

6 In the table, enter the following settings:

Parameter name	Parameter value list	Parameter unit
sigma_pre (Initial normal stress)	range (1, 1, 3)	GPa

7 Right-click **Study 3 - Frequency Response: Solid Losses (ht-solid) > Step 1: Stationary** and choose **Compute Selected Step**.

Step 2: Frequency-Domain Perturbation

1 In the **Model Builder** window, click **Step 2: Frequency-Domain Perturbation**.

2 In the **Settings** window for **Frequency-Domain Perturbation**, locate the **Study Settings** section.

3 In the **Frequencies** text field, type range (50, 50, 600) range (13150, 25, 13500).

4 Locate the **Values of Linearization Point** section. From the **Settings** list, choose **User controlled**.

5 From the **Parameter value (sigma_pre (GPa))** list, choose **3 GPa**.

6 Locate the **Physics and Variables Selection** section. In the **Solve for** column of the table, under **Component 1 (comp1)**, clear the checkboxes for **Thermoviscous Acoustics**, **Frequency Domain (ta)**, **Pressure Acoustics**, **Frequency Domain (acpr)**, and **Moving Mesh**.

7 In the **Solve for** column of the table, under **Component 1 (comp1) > Multiphysics**, clear the checkboxes for **Acoustic–Thermoviscous Acoustic Boundary 1 (atb1)** and **Thermoviscous Acoustic–Thermoelasticity Boundary 1 (tatb1)**.

8 Right-click **Step 2: Frequency-Domain Perturbation** and choose **Compute Selected Step**.

RESULTS

Mesh 1

- 1 In the **Model Builder** window, expand the **Results** node.
- 2 Right-click **Results > Datasets** and choose **Mesh**.
Create a mesh plot.
- 3 In the **Settings** window for **Mesh**, click  **Plot**.

Mesh Plot

- 1 In the **Results** toolbar, click  **3D Plot Group**.
- 2 In the **Settings** window for **3D Plot Group**, type Mesh Plot in the **Label** text field.
- 3 Locate the **Data** section. From the **Dataset** list, choose **Mesh 1**.
- 4 Click to expand the **Selection** section. Click to expand the **Title** section. Locate the **Plot Settings** section. Select the **Propagate hiding to lower dimensions** checkbox.
- 5 Locate the **Color Legend** section. Select the **Show maximum and minimum values** checkbox.

Mesh 1

- 1 Right-click **Mesh Plot** and choose **Mesh**.
- 2 In the **Settings** window for **Mesh**, locate the **Level** section.
- 3 From the **Level** list, choose **Volume**.
- 4 Click to expand the **Element Filter** section. Select the **Enable filter** checkbox.
- 5 In the **Expression** text field, type $x < 0.5$ [mm].

6 In the **Mesh Plot** toolbar, click  **Plot**.

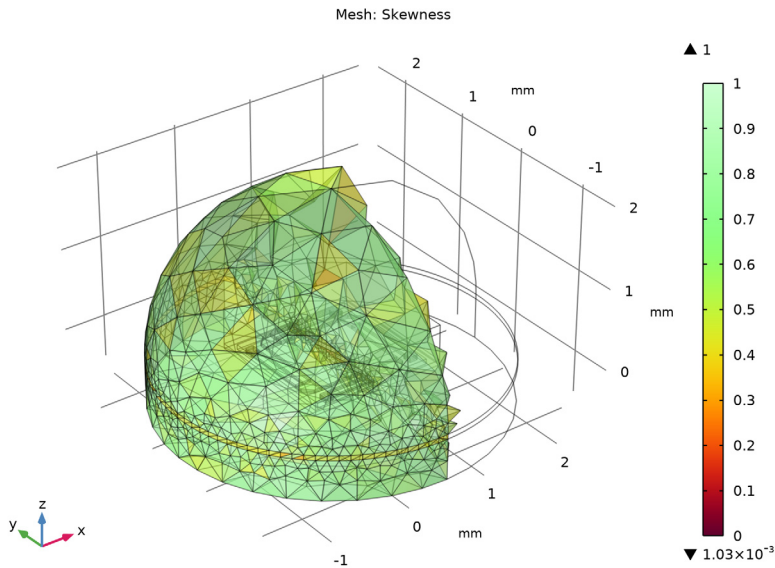

Plot the mode shapes from the eigenfrequency study.

Mode Shape (solid)

- 1 In the **Results** toolbar, click  **3D Plot Group**.
- 2 In the **Settings** window for **3D Plot Group**, type **Mode Shape (solid)** in the **Label** text field.
- 3 Locate the **Plot Settings** section. From the **Frame** list, choose **Spatial (x, y, z)**.
- 4 Locate the **Color Legend** section. Clear the **Show legends** checkbox.

Surface 1

Right-click **Mode Shape (solid)** and choose **Surface**.

Deformation 1

- 1 In the **Model Builder** window, right-click **Surface 1** and choose **Deformation**.
- 2 In the **Mode Shape (solid)** toolbar, click  **Plot**.

3 In the **Model Builder** window, click **Deformation 1**.

Eigenfrequency=13336 Hz

Displacement magnitude (mm)

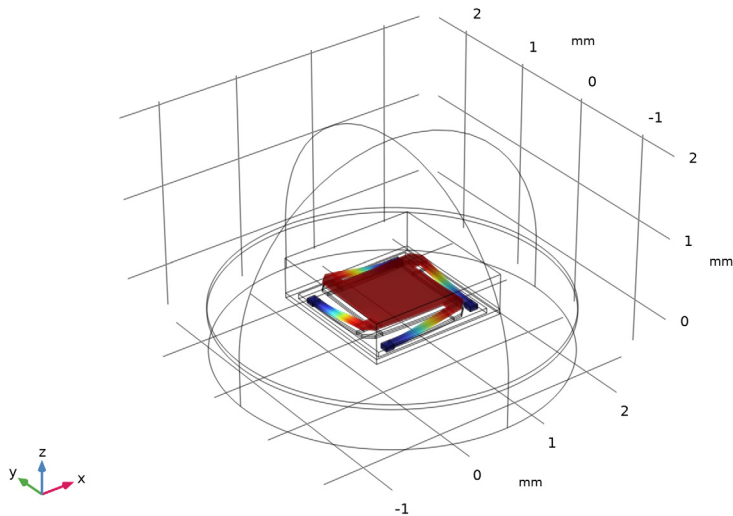

Plot the stress from the stationary study for the full model.

Stress (stationary)

- 1 In the **Results** toolbar, click  **3D Plot Group**.
- 2 In the **Settings** window for **3D Plot Group**, type **Stress (stationary)** in the **Label** text field.
- 3 Locate the **Data** section. From the **Dataset** list, choose **Study 2 - Frequency Response: Full Model (ta-ht-solid)/Solution Store 2 (sol4)**.
- 4 Locate the **Plot Settings** section. From the **Frame** list, choose **Spatial (x, y, z)**.
- 5 Locate the **Data** section. From the **Parameter value (sigma_pre (GPa))** list, choose **3**.

Volume 1

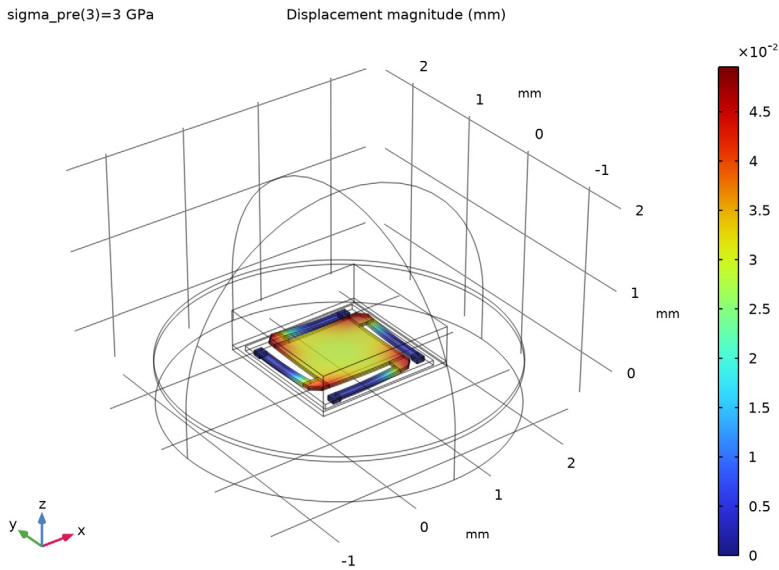

- 1 Right-click **Stress (stationary)** and choose **Volume**.
- 2 In the **Stress (stationary)** toolbar, click  **Plot**.

3 In the **Model Builder** window, click **Volume 1**.



Plot the displacement from the stationary study for the full model.

Displacement (stationary)

- 1 In the **Results** toolbar, click  **3D Plot Group**.
- 2 In the **Settings** window for **3D Plot Group**, type **Displacement (stationary)** in the **Label** text field.
- 3 Locate the **Data** section. From the **Dataset** list, choose **Study 2 - Frequency Response: Full Model (ta-ht-solid)/Solution Store 2 (sol4)**.
- 4 From the **Parameter value (sigma_pre (GPa))** list, choose **3**.
- 5 Locate the **Plot Settings** section. From the **Frame** list, choose **Spatial (x, y, z)**.
- 6 Locate the **Color Legend** section. Select the **Show maximum and minimum values** checkbox.
- 7 Select the **Show units** checkbox.
- 8 In the **Displacement (stationary)** toolbar, click  **Plot**.

Surface 1

- 1 Right-click **Displacement (stationary)** and choose **Surface**.
- 2 In the **Displacement (stationary)** toolbar, click  **Plot**.

3 In the **Model Builder** window, click **Surface 1**.

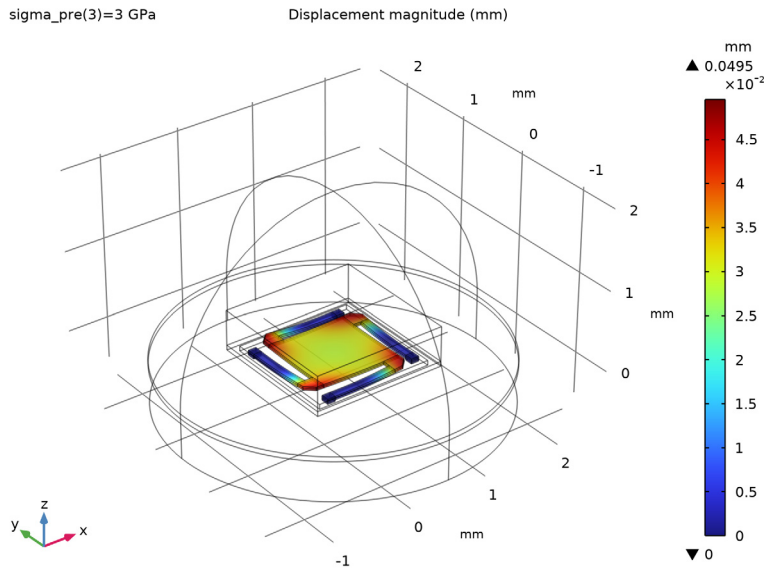

Plot the temperature from the stationary study for the full model.

Temperature (stationary)

- 1 In the **Results** toolbar, click  **3D Plot Group**.
- 2 In the **Settings** window for **3D Plot Group**, type **Temperature (stationary)** in the **Label** text field.
- 3 Locate the **Data** section. From the **Dataset** list, choose **Study 2 - Frequency Response: Full Model (ta-ht-solid)/Solution Store 2 (sol4)**.
- 4 From the **Parameter value (sigma_pre (GPa))** list, choose **3**.
- 5 Locate the **Plot Settings** section. From the **Frame** list, choose **Spatial (x, y, z)**.

Surface 1

- 1 Right-click **Temperature (stationary)** and choose **Surface**.
- 2 In the **Settings** window for **Surface**, locate the **Expression** section.
- 3 In the **Expression** text field, type **T**.

4 In the **Temperature (stationary)** toolbar, click  **Plot**.

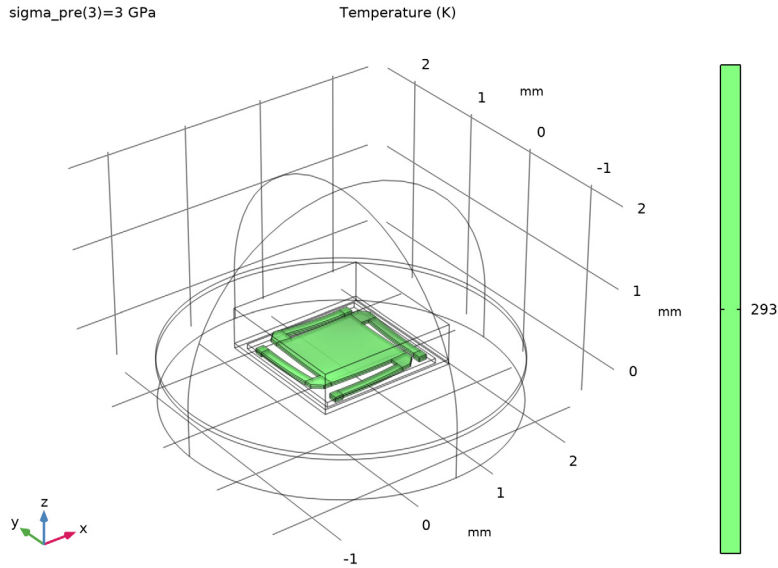

Plot the displacement from the frequency domain perturbation study for the full model.

Displacement (perturbation)

- 1 In the **Results** toolbar, click  **3D Plot Group**.
- 2 In the **Settings** window for **3D Plot Group**, type **Displacement (perturbation)** in the **Label** text field.
- 3 Locate the **Data** section. From the **Dataset** list, choose **Study 2 - Frequency Response: Full Model (ta-ht-solid)/Solution 3 (sol3)**.
- 4 Locate the **Title** section. From the **Title type** list, choose **Label**.
- 5 Locate the **Plot Settings** section. From the **Frame** list, choose **Spatial (x, y, z)**.
- 6 Locate the **Color Legend** section. Select the **Show units** checkbox.

Surface I

Right-click **Displacement (perturbation)** and choose **Surface**.

Deformation I

- 1 In the **Model Builder** window, right-click **Surface I** and choose **Deformation**.
- 2 In the **Displacement (perturbation)** toolbar, click  **Plot**.

3 In the **Model Builder** window, click **Deformation 1**.

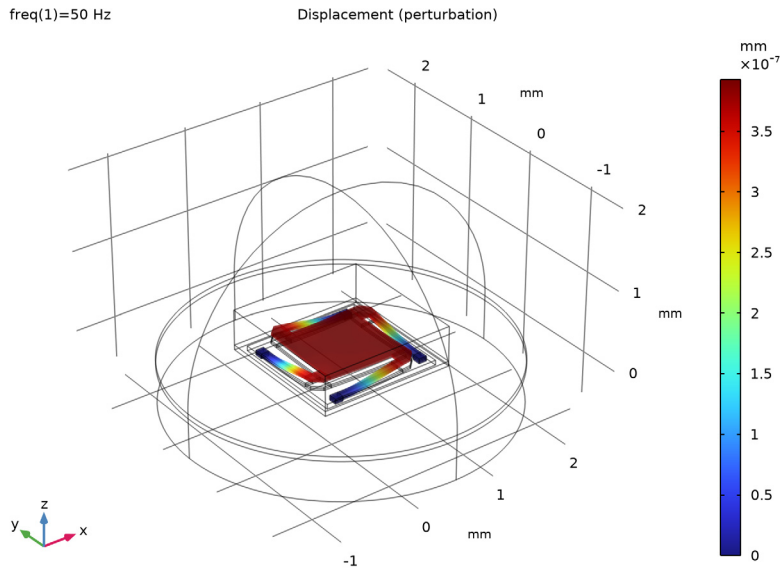

Plot the temperature from the frequency domain perturbation study for the full model.

Temperature (perturbation)

- 1 In the **Results** toolbar, click  **3D Plot Group**.
- 2 In the **Settings** window for **3D Plot Group**, type **Temperature (perturbation)** in the **Label** text field.
- 3 Locate the **Data** section. From the **Dataset** list, choose **Study 2 - Frequency Response: Full Model (ta-ht-solid)/Solution 3 (sol3)**.
- 4 Locate the **Title** section. From the **Title type** list, choose **Label**.
- 5 Locate the **Plot Settings** section. Clear the **Plot dataset edges** checkbox.
- 6 Locate the **Color Legend** section. Select the **Show units** checkbox.

Surface 1

- 1 Right-click **Temperature (perturbation)** and choose **Surface**.
- 2 In the **Settings** window for **Surface**, locate the **Expression** section.
- 3 In the **Expression** text field, type **T**.
- 4 From the **Unit** list, choose **mK**.
- 5 Locate the **Coloring and Style** section. From the **Color table** list, choose **ThermalWave**.

6 In the **Temperature (perturbation)** toolbar, click  **Plot**.

Deformation 1

- 1** Right-click **Surface 1** and choose **Deformation**.
- 2** In the **Settings** window for **Deformation**, locate the **Scale** section.
- 3** Select the **Scale factor** checkbox. In the associated text field, type 1.

Filter 1

- 1** In the **Model Builder** window, right-click **Surface 1** and choose **Filter**.
- 2** In the **Settings** window for **Filter**, locate the **Element Selection** section.
- 3** In the **Logical expression for inclusion** text field, type $x < 0.5$ [mm].

Selection 1

- 1** Right-click **Surface 1** and choose **Selection**.
- 2** In the **Settings** window for **Selection**, locate the **Selection** section.
- 3** From the **Selection** list, choose **Solid-TA**.

Slice 1

- 1** In the **Model Builder** window, right-click **Temperature (perturbation)** and choose **Slice**.
- 2** In the **Settings** window for **Slice**, locate the **Expression** section.
- 3** In the **Expression** text field, type $t_a \cdot T_t$.
- 4** From the **Unit** list, choose **mK**.
- 5** Locate the **Plane Data** section. In the **Planes** text field, type 1.
- 6** Locate the **Coloring and Style** section. Clear the **Color legend** checkbox.
- 7** Click to expand the **Inherit Style** section. From the **Plot** list, choose **Surface 1**.
- 8** In the **Temperature (perturbation)** toolbar, click  **Plot**.

Transparency 1

- 1** Right-click **Slice 1** and choose **Transparency**.
- 2** In the **Settings** window for **Transparency**, locate the **Transparency** section.
- 3** Find the **Transparency** subsection. In the **Transparency** text field, type 0.05.
- 4** Find the **Fresnel transmittance** subsection. In the **Fresnel transmittance** text field, type 0.1.
- 5** In the **Temperature (perturbation)** toolbar, click  **Plot**.

Slice 2

- 1** In the **Model Builder** window, right-click **Temperature (perturbation)** and choose **Slice**.

- 2 In the **Settings** window for **Slice**, locate the **Expression** section.
- 3 In the **Expression** text field, type T.
- 4 From the **Unit** list, choose **mK**.
- 5 Locate the **Coloring and Style** section. Clear the **Color legend** checkbox.
- 6 Locate the **Inherit Style** section. From the **Plot** list, choose **Surface I**.
- 7 In the **Temperature (perturbation)** toolbar, click  **Plot**.

Volume I

- 1 Right-click **Temperature (perturbation)** and choose **Volume**.
- 2 In the **Settings** window for **Volume**, locate the **Expression** section.
- 3 In the **Expression** text field, type 1.
- 4 Locate the **Coloring and Style** section. From the **Coloring** list, choose **Uniform**.
- 5 From the **Color** list, choose **Custom**.
- 6 On Windows, click the colored bar underneath, or — if you are running the cross-platform desktop — the **Color** button.
- 7 Click **Define custom colors**.
- 8 Set the RGB values to 224, 255, and 255, respectively.
- 9 Click **Add to custom colors**.
- 10 Click **Show color palette only** or **OK** on the cross-platform desktop.

Selection I

- 1 Right-click **Volume I** and choose **Selection**.
- 2 In the **Settings** window for **Selection**, locate the **Selection** section.
- 3 Click  **Paste Selection**.
- 4 In the **Paste Selection** dialog, type 1 2 4 in the **Selection** text field.
- 5 Click **OK**.

Material Appearance I

- 1 In the **Model Builder** window, right-click **Volume I** and choose **Material Appearance**.
- 2 In the **Settings** window for **Material Appearance**, locate the **Appearance** section.
- 3 From the **Appearance** list, choose **Custom**.
- 4 From the **Material type** list, choose **Aluminum (anodized)**.
- 5 Locate the **Color** section. Select the **Use the plot's color** checkbox.
- 6 In the **Temperature (perturbation)** toolbar, click  **Plot**.

Line 1

- 1 In the **Model Builder** window, right-click **Temperature (perturbation)** and choose **Line**.
- 2 In the **Settings** window for **Line**, locate the **Coloring and Style** section.
- 3 From the **Coloring** list, choose **Uniform**.
- 4 From the **Color** list, choose **Black**.
- 5 In the **Temperature (perturbation)** toolbar, click  **Plot**.

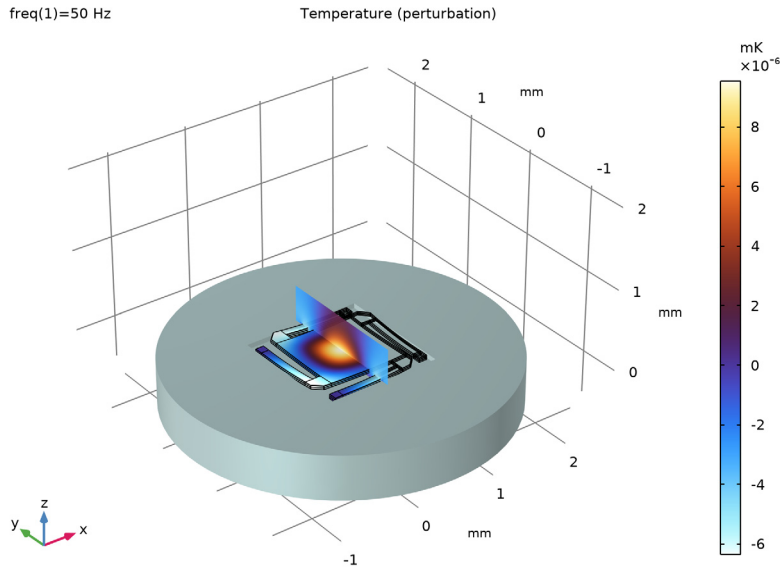

Create a slice plot of the acoustic velocity from the frequency domain perturbation study for the full model.

Acoustic Velocity (perturbation)

- 1 In the **Results** toolbar, click  **3D Plot Group**.
- 2 In the **Settings** window for **3D Plot Group**, type **Acoustic Velocity (perturbation)** in the **Label** text field.
- 3 Locate the **Data** section. From the **Dataset** list, choose **Study 2 - Frequency Response: Full Model (ta-ht-solid)/Solution 3 (sol3)**.
- 4 Locate the **Plot Settings** section. From the **Frame** list, choose **Spatial (x, y, z)**.
- 5 Locate the **Color Legend** section. Select the **Show units** checkbox.

Slice 1

- 1 Right-click **Acoustic Velocity (perturbation)** and choose **Slice**.
- 2 In the **Settings** window for **Slice**, locate the **Expression** section.
- 3 In the **Expression** text field, type `ta.v_inst`.
- 4 From the **Unit** list, choose **mm/s**.
- 5 Locate the **Plane Data** section. In the **Planes** text field, type `1`.
- 6 In the **Acoustic Velocity (perturbation)** toolbar, click  **Plot**.

Transparency 1

- 1 Right-click **Slice 1** and choose **Transparency**.
- 2 In the **Settings** window for **Transparency**, locate the **Transparency** section.
- 3 Find the **Transparency** subsection. In the **Transparency** text field, type `0.1`.
- 4 Find the **Fresnel transmittance** subsection. In the **Fresnel transmittance** text field, type `0.1`.
- 5 In the **Acoustic Velocity (perturbation)** toolbar, click  **Plot**.

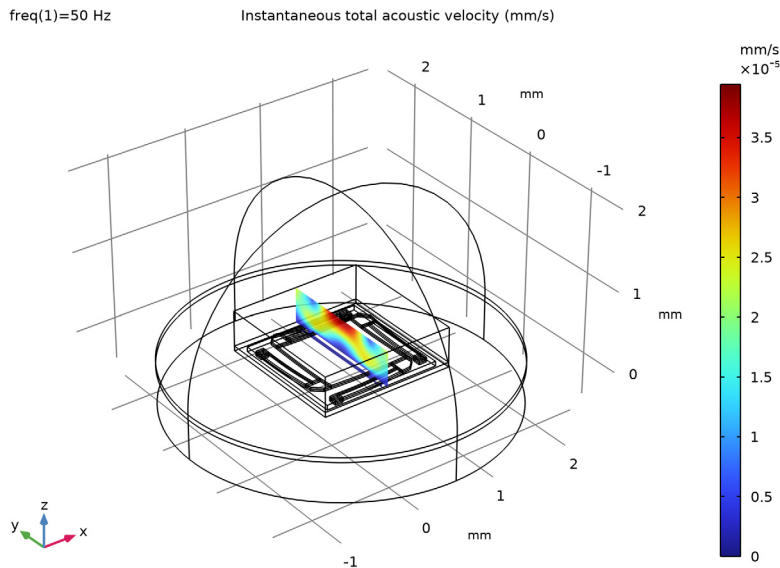

Create a slice plot of the acoustic pressure from the frequency domain perturbation study for the full model.

Acoustic Pressure (perturbation)

- 1 In the **Results** toolbar, click  **3D Plot Group**.
- 2 In the **Settings** window for **3D Plot Group**, type **Acoustic Pressure (perturbation)** in the **Label** text field.
- 3 Locate the **Data** section. From the **Dataset** list, choose **Study 2 - Frequency Response: Full Model (ta-ht-solid)/Solution 3 (sol3)**.
- 4 Locate the **Plot Settings** section. From the **Frame** list, choose **Spatial (x, y, z)**.
- 5 Locate the **Color Legend** section. Select the **Show units** checkbox.

Slice 1

- 1 Right-click **Acoustic Pressure (perturbation)** and choose **Slice**.
- 2 In the **Settings** window for **Slice**, locate the **Expression** section.
- 3 In the **Expression** text field, type `ta.p_t`.
- 4 Locate the **Plane Data** section. In the **Planes** text field, type `1`.
- 5 Locate the **Coloring and Style** section. From the **Color table** list, choose **Wave**.
- 6 From the **Scale** list, choose **Linear symmetric**.
- 7 In the **Acoustic Pressure (perturbation)** toolbar, click  **Plot**.

Transparency 1

- 1 Right-click **Slice 1** and choose **Transparency**.
- 2 In the **Settings** window for **Transparency**, locate the **Transparency** section.
- 3 Find the **Transparency** subsection. In the **Transparency** text field, type `0.1`.
- 4 Find the **Fresnel transmittance** subsection. In the **Fresnel transmittance** text field, type `0.1`.
- 5 In the **Acoustic Pressure (perturbation)** toolbar, click  **Plot**.

Slice 2

- 1 In the **Model Builder** window, right-click **Acoustic Pressure (perturbation)** and choose **Slice**.
- 2 In the **Settings** window for **Slice**, locate the **Expression** section.
- 3 In the **Expression** text field, type `acpr.p_t`.
- 4 Locate the **Plane Data** section. In the **Planes** text field, type `1`.
- 5 Locate the **Inherit Style** section. From the **Plot** list, choose **Slice 1**.
- 6 In the **Acoustic Pressure (perturbation)** toolbar, click  **Plot**.

Transparency 1

- 1 Right-click **Slice 2** and choose **Transparency**.
- 2 In the **Acoustic Pressure (perturbation)** toolbar, click  **Plot**.
- 3 In the **Model Builder** window, click **Transparency 1**.

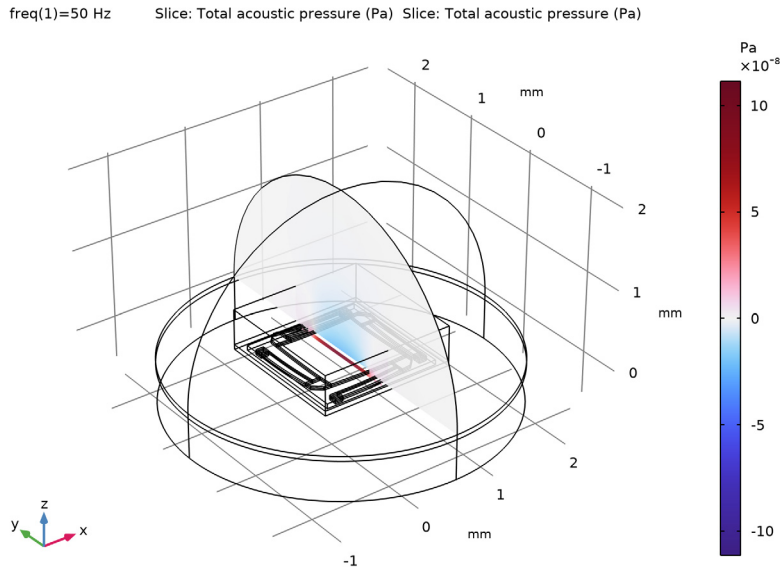

Plot the displacement versus the frequency to compare the response of full model with the response of the model with only solid losses near the resonance.

Response Comparison (at resonance)

- 1 In the **Results** toolbar, click  **ID Plot Group**.
- 2 In the **Settings** window for **ID Plot Group**, type Response Comparison (at resonance) in the **Label** text field.
- 3 Locate the **Data** section. From the **Dataset** list, choose **Study 2 - Frequency Response: Full Model (ta-ht-solid)/Solution 3 (sol3)**.
- 4 From the **Parameter selection (freq)** list, choose **Manual**.
- 5 In the **Parameter indices (1-27)** text field, type range (13, 1, 27).

Point Graph 1

- 1 Right-click **Response Comparison (at resonance)** and choose **Point Graph**.
- 2 In the **Settings** window for **Point Graph**, locate the **Selection** section.

- 3 Click  **Paste Selection**.
- 4 In the **Paste Selection** dialog, type 97 in the **Selection** text field.
- 5 Click **OK**.
- 6 In the **Settings** window for **Point Graph**, locate the **y-Axis Data** section.
- 7 In the **Expression** text field, type `abs(w)`.
- 8 Click to expand the **Coloring and Style** section. From the **Width** list, choose **I**.
- 9 Click to expand the **Legends** section. Select the **Show legends** checkbox.
- 10 From the **Legends** list, choose **Manual**.
- 11 In the table, enter the following settings:

Legends
Full Model (ta-ht-solid)

- 12 In the **Response Comparison (at resonance)** toolbar, click  **Plot**.

Point Graph 2

- 1 Right-click **Point Graph 1** and choose **Duplicate**.
- 2 In the **Settings** window for **Point Graph**, locate the **Data** section.
- 3 From the **Dataset** list, choose **Study 3 - Frequency Response: Solid Losses (ht-solid)/ Solution 5 (sol5)**.
- 4 From the **Parameter selection (freq)** list, choose **Manual**.
- 5 In the **Parameter indices (1-27)** text field, type `range(13, 1, 27)`.
- 6 Locate the **Legends** section. In the table, enter the following settings:

Legends
Solid Losses (ht-solid)

7 In the **Response Comparison (at resonance)** toolbar, click  **Plot**.

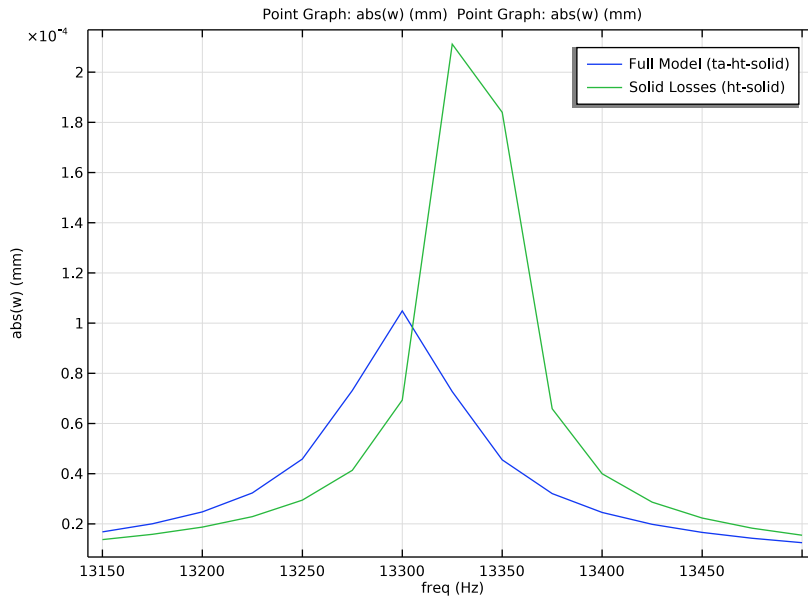

Plot the displacement versus the frequency to compare the response of the full model with the response of the model with only solid losses between 50 and 600 Hz.

Response Comparison (typical operation)

- 1 In the **Results** toolbar, click  **ID Plot Group**.
- 2 In the **Settings** window for **ID Plot Group**, type Response Comparison (typical operation) in the **Label** text field.
- 3 Locate the **Data** section. From the **Dataset** list, choose **Study 2 - Frequency Response: Full Model (ta-ht-solid)/Solution 3 (sol3)**.
- 4 From the **Parameter selection (freq)** list, choose **Manual**.
- 5 In the **Parameter indices (1-27)** text field, type range (1, 1, 12).

Point Graph 1

- 1 Right-click **Response Comparison (typical operation)** and choose **Point Graph**.
- 2 In the **Settings** window for **Point Graph**, locate the **Selection** section.
- 3 Click  **Paste Selection**.
- 4 In the **Paste Selection** dialog, type 97 in the **Selection** text field.
- 5 Click **OK**.

- 6 In the **Settings** window for **Point Graph**, locate the **y-Axis Data** section.
- 7 In the **Expression** text field, type `abs(w)`.
- 8 Locate the **Coloring and Style** section. From the **Width** list, choose **1**.
- 9 Locate the **Legends** section. Select the **Show legends** checkbox.
- 10 From the **Legends** list, choose **Manual**.
- 11 In the table, enter the following settings:

Legends
Full Model (ta-ht-solid)

- 12 In the **Response Comparison (typical operation)** toolbar, click  **Plot**.

Point Graph 2

- 1 Right-click **Point Graph 1** and choose **Duplicate**.
- 2 In the **Settings** window for **Point Graph**, locate the **Data** section.
- 3 From the **Dataset** list, choose **Study 3 - Frequency Response: Solid Losses (ht-solid)/ Solution 5 (sol5)**.
- 4 From the **Parameter selection (freq)** list, choose **Manual**.
- 5 In the **Parameter indices (1-27)** text field, type `range(1,1,12)`.
- 6 Locate the **Legends** section. In the table, enter the following settings:

Legends
Solid Losses (ht-solid)

7 In the **Response Comparison (typical operation)** toolbar, click  **Plot**.

