



Model created in COMSOL Multiphysics 6.4

Prestressed Micromirror

Introduction

One method of creating spring-like structures or inducing curvature in plated structures is to plate materials onto a substrate such that the layer has a residual stress after the plating process. The plating process can control this stress, which can be either compressive or tensile, even for similar materials. The automotive industry has studied this phenomenon at length because highly stressed chrome is appreciably shinier than nonstressed chrome. MEMS device manufacturers sometimes use this effect to create curved cantilevers or spring-loaded micromechanical structures that lift off the substrate when deliberately undercut by an etchant.

One such device is the electrostatically controlled micromirror. It is typically quite small, and arrays of such devices can implement a projection system. They serve as optical redirectors and similar reflection devices. This section shows the fundamentals of how to set up and solve lift-off of a prestressed plated device.

Model Definition

This single-physics model uses 3D structural analysis. The micromirror has a stiff, flat, reflective center portion, which is supported by four prestressed plated cantilever springs. To keep the mesh size small and the solution time reasonable, this exercise studies the plated structure with two layers. It also assumes that the plating process creates equal and opposite (compressive and tensile) initial stresses in the top and bottom layers. This convenience makes the model straightforward to set up. You can make the initial-stress distribution as complex as desired and set it up as shown in this example. Depending on the magnitude of the deformations, you are likely best advised to solve such simulations with a large-deformation analysis using a nonlinear or parametric nonlinear solver, noting that the latter is more likely to converge. Thus this illustrative model uses the large-deformation analysis type with both the linear and parametric linear solvers.

Note in particular that a 3D structure with thin layers such as the one in this model leads to a very large unstructured tetrahedral mesh. To avoid this case, this example first generates a 2D quadrilateral mesh by mesh mapping and then extrudes it into 3D to produce a mesh with hexahedral (brick) elements. This way you can have the mesher create structured elements with a high aspect ratio.

One of the key process parameters you wish to determine in this class of problem is generally what prestress level is necessary to result in a desired lift-off. Another common concern is how much effect variations in the prestress might have on displacement. A parametric study answers this question.

Results and Discussion

The following two images compare lift-off for aluminum and steel plates. The steel, being stiffer than aluminum, deforms less.

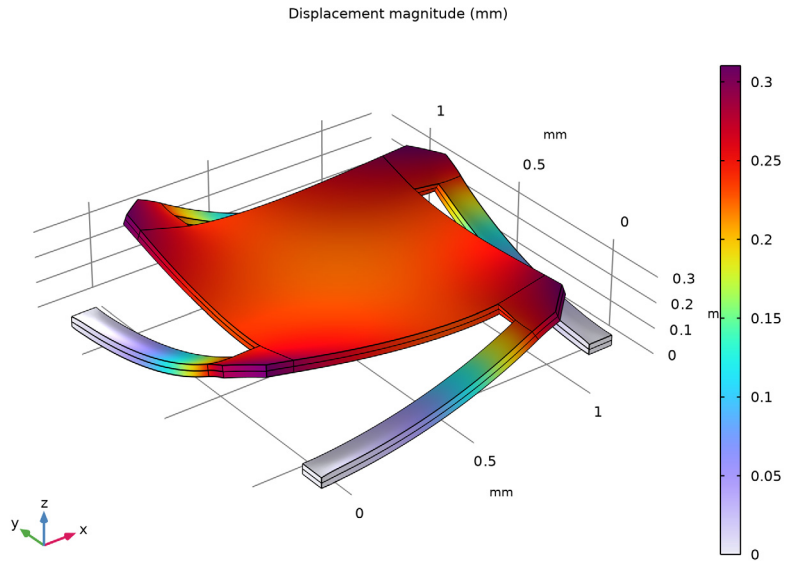

Figure 1: Lift-off for aluminum.

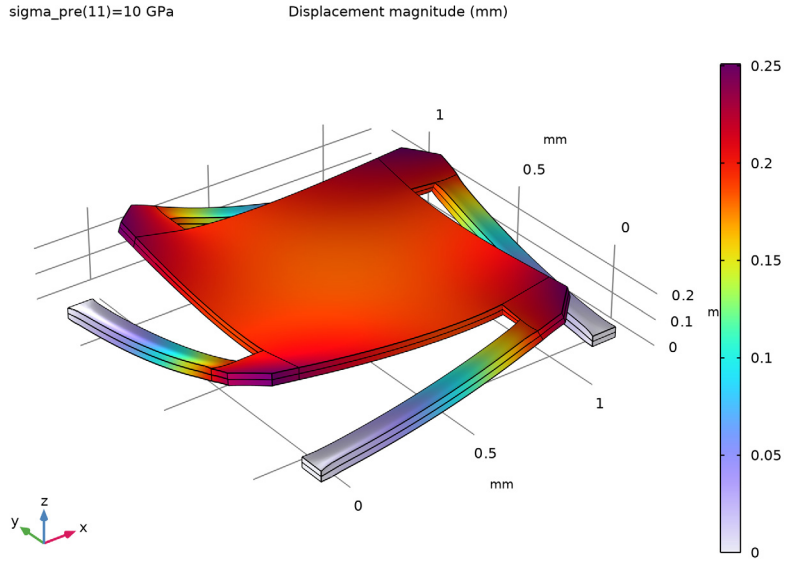

Figure 2: Lift-off for steel.

The following two figures show the mirror response to the different levels of applied prestress. According to [Figure 3](#), the centerpoint deflection is almost linearly dependent

on the prestress. Figure 4 shows the mirror's curvature along its centerline for different values of prestress. In line with expectations, increasing the stress bends the mirror more.

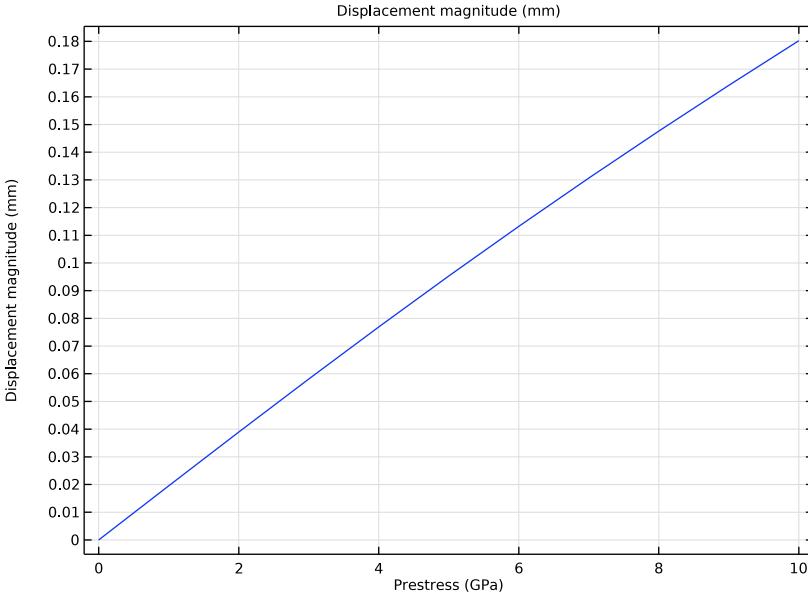

Figure 3: Total deflection of the center of the mirror for different prestress levels.

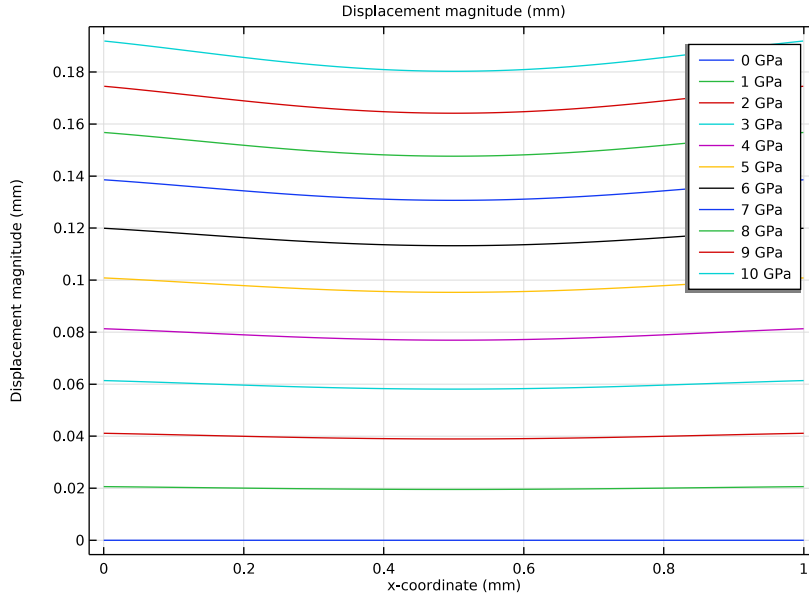

Figure 4: Mirror curvature along the centerline for different prestress levels.

Reference

1. G. Kovacs, *Micromachined Transducers Sourcebook*, WCM McGraw Hill, 1998.

Application Library path: MEMS_Module/Actuators/micromirror

Modeling Instructions



From the **File** menu, choose **New**.

NEW

In the **New** window, click  **Model Wizard**.

MODEL WIZARD

1 In the **Model Wizard** window, click  **3D**.

- 2 In the **Select Physics** tree, select **Structural Mechanics > Solid Mechanics (solid)**.
- 3 Click **Add**.
- 4 Click  **Study**.
- 5 In the **Select Study** tree, select **General Studies > Stationary**.
- 6 Click  **Done**.

The Model Wizard starts the COMSOL Desktop with the **Geometry** node selected. We can take the chance to set the length unit to a more convenient one.

GEOMETRY I

- 1 In the **Model Builder** window, under **Component I (comp1)** click **Geometry I**.
- 2 In the **Settings** window for **Geometry**, locate the **Units** section.
- 3 From the **Length unit** list, choose **mm**.

Now set up some global parameters.

GLOBAL DEFINITIONS

Parameters I

- 1 In the **Model Builder** window, under **Global Definitions** click **Parameters I**.
- 2 In the **Settings** window for **Parameters**, locate the **Parameters** section.
- 3 In the table, enter the following settings:

Name	Expression	Value	Description
sigma_pre	5[GPa]	5E9 Pa	Initial normal stress

GEOMETRY I



Work Plane I (wp1)

- 1 In the **Geometry** toolbar, click  **Work Plane**.
- 2 In the **Settings** window for **Work Plane**, click  **Go to Plane Geometry**.



Work Plane I (wp1) > Plane Geometry

In the **Model Builder** window, click **Plane Geometry**.



Work Plane I (wp1) > Square I (sq1)

- 1 In the **Work Plane** toolbar, click  **Square**.
- 2 In the **Settings** window for **Square**, click  **Build Selected**.



Work Plane 1 (wp1) > Square 2 (sq2)

- 1 In the **Work Plane** toolbar, click  **Square**.
- 2 In the **Settings** window for **Square**, locate the **Size** section.
- 3 In the **Side length** text field, type 0.2.
- 4 Locate the **Position** section. In the **yw** text field, type 1.
- 5 Click  **Build Selected**.
- 6 Click the  **Zoom Extents** button in the **Graphics** toolbar.



Work Plane 1 (wp1) > Chamfer 1 (cha1)

- 1 In the **Work Plane** toolbar, click  **Chamfer**.
- 2 On the object **sq2**, select Point 4 only.
- 3 In the **Settings** window for **Chamfer**, locate the **Distance** section.
- 4 In the **Distance from vertex** text field, type 0.1.
- 5 Click  **Build Selected**.

Work Plane 1 (wp1) > Rectangle 1 (r1)

- 1 In the **Work Plane** toolbar, click  **Rectangle**.
- 2 In the **Settings** window for **Rectangle**, locate the **Size and Shape** section.
- 3 In the **Width** text field, type 0.9.
- 4 In the **Height** text field, type 0.1.
- 5 Locate the **Position** section. In the **xw** text field, type 0.2.
- 6 In the **yw** text field, type 1.1.
- 7 Click  **Build Selected**.

Work Plane 1 (wp1) > Rotate 1 (rot1)

- 1 In the **Work Plane** toolbar, click  **Transforms** and choose **Rotate**.
- 2 Select the objects **cha1** and **r1** only.
- 3 In the **Settings** window for **Rotate**, locate the **Rotation** section.
- 4 In the **Angle** text field, type range (90,90,360).
- 5 Locate the **Center of Rotation** section. In the **xw** text field, type 0.5.
- 6 In the **yw** text field, type 0.5.
- 7 Click  **Build Selected**.

Extrude 1 (ext1)



- 1 In the **Model Builder** window, under **Component 1 (comp1)** > **Geometry 1** right-click **Work Plane 1 (wp1)** and choose **Extrude**.
- 2 In the **Settings** window for **Extrude**, locate the **Distances** section.
- 3 In the table, enter the following settings:

Distances (mm)
0.02
0.04



- 4 Click  **Build Selected**.

This creates two layers with thickness of 0.02 mm each (not one of 0.04 mm on top of one of 0.02 mm).

Form Union (fin)

- 1 In the **Model Builder** window, click **Form Union (fin)**.
- 2 In the **Settings** window for **Form Union/Assembly**, click  **Build Selected**.
- 3 Click the  **Zoom Extents** button in the **Graphics** toolbar.

ADD MATERIAL

- 1 In the **Materials** toolbar, click  **Add Material** to open the **Add Material** window.
- 2 Go to the **Add Material** window.
- 3 In the tree, select **Built-in** > **Aluminum**.
- 4 Click the **Add to Component** button in the window toolbar.
- 5 In the **Materials** toolbar, click  **Add Material** to close the **Add Material** window.

MATERIALS

Aluminum (mat1)

By default the first material you add applies to all domains, so you do not need to change the settings in the **Geometric Entity Selection**.



You can inspect which material properties are used and what values they take in the **Material Contents** table.

SOLID MECHANICS (SOLID)

Linear Elastic Material 1

In the **Model Builder** window, under **Component 1 (comp1) > Solid Mechanics (solid)** click **Linear Elastic Material 1**.

Initial Stress and Strain 1

- 1 In the **Physics** toolbar, click  **Attributes** and choose **Initial Stress and Strain**.
- 2 In the **Settings** window for **Initial Stress and Strain**, locate the **Domain Selection** section.
- 3 Click  **Clear Selection**.
- 4 Select Domains 4, 6, 12, and 18 only.

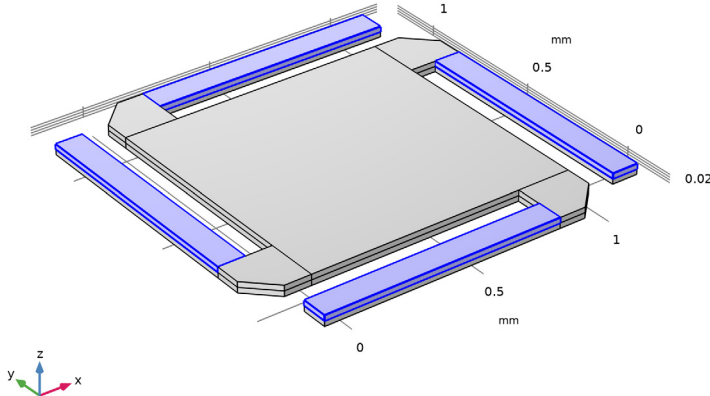

- 5 Locate the **Initial Stress and Strain** section. Specify the S_0 matrix as

sigma_pre	0	0
0	sigma_pre	0
0	0	0

Linear Elastic Material 1

In the **Model Builder** window, click **Linear Elastic Material 1**.

Initial Stress and Strain 2

- 1 In the **Physics** toolbar, click  **Attributes** and choose **Initial Stress and Strain**.
- 2 In the **Settings** window for **Initial Stress and Strain**, locate the **Domain Selection** section.

3 Click  **Clear Selection**.

4 Select Domains 3, 5, 11, and 17 only.

5 Locate the **Initial Stress and Strain** section. Specify the S_0 matrix as

-sigma_pre	0	0
0	-sigma_pre	0
0	0	0

Fixed Constraint 1

1 In the **Physics** toolbar, click  **Boundaries** and choose **Fixed Constraint**.

2 Select Boundaries 15–17, 20, 92, 95, 102, and 103 only.

It might be easier to select the correct boundaries by using the **Selection List** window.

To open this window, in the **Home** toolbar click **Windows** and choose **Selection List**. (If you are running the cross-platform desktop, you find **Windows** in the main menu.)

3 Click the  **Zoom Extents** button in the **Graphics** toolbar.

MESH 1

Mapped 1

1 In the **Mesh** toolbar, click  **More Generators** and choose **Mapped**.

2 Select Boundaries 7, 14, 23, 38, 47, 62, 71, 88, and 97 only.

Distribution 1

1 Right-click **Mapped 1** and choose **Distribution**.

- 2 Select Edges 15, 29, 57, 62, 88, 101, 134, and 177 only.

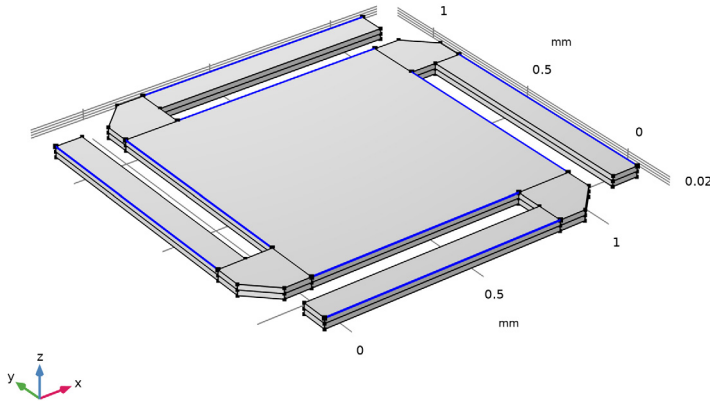

- 3 In the **Settings** window for **Distribution**, locate the **Distribution** section.
- 4 In the **Number of elements** text field, type 12.

Distribution 2

- 1 In the **Model Builder** window, right-click **Mapped 1** and choose **Distribution**.
- 2 Select Edges 21, 28, 47, 87, 114, 142, 155, and 170 only.
- 3 In the **Settings** window for **Distribution**, locate the **Distribution** section.
- 4 In the **Number of elements** text field, type 3.

Distribution 3

- 1 Right-click **Mapped 1** and choose **Distribution**.
- 2 Select Edges 7, 80, 109, and 182 only.
- 3 In the **Settings** window for **Distribution**, locate the **Distribution** section.
- 4 In the **Number of elements** text field, type 6.

Mapped 1

- 1 Right-click **Mapped 1** and choose **Build Selected**.
- 2 Click the  **Zoom Extents** button in the **Graphics** toolbar.

Swept 1

- 1 In the **Mesh** toolbar, click  **Swept**.

- 2 In the **Settings** window for **Swept**, click  **Build Selected**.

STUDY 1

Step 1: Stationary

- 1 In the **Model Builder** window, under **Study 1** click **Step 1: Stationary**.
- 2 In the **Settings** window for **Stationary**, locate the **Study Settings** section.
- 3 Select the **Include geometric nonlinearity** checkbox.

Solution 1 (sol1)

- 1 In the **Study** toolbar, click  **Show Default Solver**.
- 2 In the **Model Builder** window, expand the **Solution 1 (sol1)** node.
- 3 In the **Model Builder** window, expand the **Study 1 > Solver Configurations > Solution 1 (sol1) > Dependent Variables 1** node, then click **Displacement Field (comp1.u)**.
- 4 In the **Settings** window for **Field**, locate the **Residual Scaling** section.
- 5 From the **Method** list, choose **Manual**.

The initial stress value used in the auxiliary sweep is 0 GPa so here it is best to use manual residual scaling.

- 6 In the **Model Builder** window, expand the **Study 1 > Solver Configurations > Solution 1 (sol1) > Stationary Solver 1** node, then click **Fully Coupled 1**.
- 7 In the **Settings** window for **Fully Coupled**, click to expand the **Method and Termination** section.
- 8 From the **Nonlinear method** list, choose **Constant (Newton)**.
Sometimes the automatic Newton nonlinear solver is too conservative, so here we choose the solver with constant damping.
- 9 In the **Study** toolbar, click  **Compute**.

RESULTS

The following steps reproduce the displacement plot shown in [Figure 1](#).

Volume 1



- 1 In the **Model Builder** window, expand the **Results > Stress (solid)** node, then click **Volume 1**.
- 2 In the **Settings** window for **Volume**, click **Replace Expression** in the upper-right corner of the **Expression** section. From the menu, choose **Component 1 (comp1) > Solid Mechanics > Displacement > solid.disp - Displacement magnitude - m**.
- 3 In the **Stress (solid)** toolbar, click  **Plot**.

4 Click the  **Zoom Extents** button in the **Graphics** toolbar.

MATERIALS

Change the plate material to steel.

ADD MATERIAL

- 1 In the **Materials** toolbar, click  **Add Material** to open the **Add Material** window.
- 2 Go to the **Add Material** window.
- 3 In the tree, select **Built-in** > **Structural steel**.
- 4 Click the **Add to Component** button in the window toolbar.
- 5 In the **Materials** toolbar, click  **Add Material** to close the **Add Material** window.

MATERIALS

Structural steel (mat2)

- 1 Select Domains 1, 2, 7–10, and 13–16 only.

The remaining domains keep their previous material, that is aluminum.

STUDY 1

Step 1: Stationary

- 1 In the **Model Builder** window, under **Study 1** click **Step 1: Stationary**.
- 2 In the **Settings** window for **Stationary**, click to expand the **Study Extensions** section.
- 3 Select the **Auxiliary sweep** checkbox.
- 4 Click  **Add**.
- 5 In the table, enter the following settings:

Parameter name	Parameter value list	Parameter unit
sigma_pre (Initial normal stress)	range(0, 1, 10)	GPa

To keep the sequence **Stationary Solver 1** intact, disable it and generate a new solver sequence.

Solution 1 (sol1)

In the **Model Builder** window, under **Study 1** > **Solver Configurations** right-click **Solution 1 (sol1)** and choose **Exclude When Computing Study**.

Solution 2 (sol2)



- 1 In the **Study** toolbar, click  **Show Default Solver**.

- 2 In the **Model Builder** window, expand the **Solution 2 (sol2)** node.
- 3 In the **Model Builder** window, expand the **Study 1 > Solver Configurations > Solution 2 (sol2) > Dependent Variables 1** node, then click **Displacement Field (comp1.u)**.
- 4 In the **Settings** window for **Field**, locate the **Residual Scaling** section.
- 5 From the **Method** list, choose **Manual**.
The initial stress value used in the auxiliary sweep is 0 GPa so here it is best to use manual residual scaling.
Repeat the settings you previously made for **Stationary Solver 1**.
- 6 In the **Model Builder** window, expand the **Study 1 > Solver Configurations > Solution 2 (sol2) > Stationary Solver 1** node, then click **Fully Coupled 1**.
- 7 In the **Settings** window for **Fully Coupled**, locate the **Method and Termination** section.
- 8 From the **Nonlinear method** list, choose **Constant (Newton)**.
- 9 In the **Model Builder** window, right-click **Solution 2 (sol2)** and choose **Run**.

RESULTS

Follow the steps below to reproduce the plot in [Figure 2](#).

Volume 1

- 1 In the **Model Builder** window, expand the **Results > Stress (solid) 1** node, then click **Volume 1**.
- 2 In the **Settings** window for **Volume**, click **Replace Expression** in the upper-right corner of the **Expression** section. From the menu, choose **solid.disp - Displacement magnitude - m**.
- 3 In the **Stress (solid) 1** toolbar, click  **Plot**.
- 4 Click the  **Zoom Extents** button in the **Graphics** toolbar.

Next, reproduce the plot in [Figure 3](#), showing the total deflection at the center of the mirror as a function of the prestress level.

Cut Point 3D 1

- 1 In the **Results** toolbar, click  **Cut Point 3D**.
- 2 In the **Settings** window for **Cut Point 3D**, locate the **Data** section.
- 3 From the **Dataset** list, choose **Study 1/Solution 2 (sol2)**.
- 4 Locate the **Point Data** section. In the **X** text field, type 0.5.
- 5 In the **Y** text field, type 0.5.
- 6 In the **Z** text field, type 0.04.

ID Plot Group 3

- 1 In the **Results** toolbar, click  **ID Plot Group**.
- 2 In the **Settings** window for **ID Plot Group**, locate the **Data** section.
- 3 From the **Dataset** list, choose **Cut Point 3D I**.
- 4 Locate the **Plot Settings** section.
- 5 Select the **x-axis label** checkbox. In the associated text field, type **Prestress (GPa)**.

Point Graph 1

- 1 Right-click **ID Plot Group 3** and choose **Point Graph**.
- 2 In the **Settings** window for **Point Graph**, click **Replace Expression** in the upper-right corner of the **y-Axis Data** section. From the menu, choose **Component 1 (comp1) > Solid Mechanics > Displacement > solid.disp - Displacement magnitude - m**.
- 3 In the **ID Plot Group 3** toolbar, click  **Plot**.
Finally, reproduce the plot in [Figure 4](#) of the total deflection along the centerline for the prestress levels included in the parametric sweep.

Cut Line 3D 1

- 1 In the **Results** toolbar, click  **Cut Line 3D**.
- 2 In the **Settings** window for **Cut Line 3D**, locate the **Data** section.
- 3 From the **Dataset** list, choose **Study 1/Solution 2 (sol2)**.
- 4 Locate the **Line Data** section. In row **Point 1**, set **Y** to 0.5 and **Z** to 0.04.

ID Plot Group 4

- 1 In the **Results** toolbar, click  **ID Plot Group**.
- 2 In the **Settings** window for **ID Plot Group**, locate the **Data** section.
- 3 From the **Dataset** list, choose **Cut Line 3D I**.

Line Graph 1

- 1 Right-click **ID Plot Group 4** and choose **Line Graph**.
Keep the default plot expression.
- 2 In the **Settings** window for **Line Graph**, click **Replace Expression** in the upper-right corner of the **x-Axis Data** section. From the menu, choose **Component 1 (comp1) > Geometry > Coordinate (spatial frame) > x - x-coordinate**.
- 3 Click to expand the **Legends** section. Select the **Show legends** checkbox.
- 4 In the **ID Plot Group 4** toolbar, click  **Plot**.