



Model created in COMSOL Multiphysics 6.4

Gecko Foot

Introduction

In nature, various species apply advanced techniques for specialized tasks. For instance, gecko lizards use dry adhesion forces such as van der Waals forces to climb walls. Dry adhesion is a phenomenon of interest for sticking because it requires no energy to hold on, and no residue is left on the surface. Gecko lizards have inspired researchers to develop synthetic gecko foot hairs for use in, for example, robots.

A strand of hair on a gecko foot is a very complex biological structure with hierarchical nanosections and microsections. On its feet, a gecko has billions of nanoscale hairs that are in contact with surfaces while it climbs. These nanohairs are attached to microscale hairs, which are on the tip of the gecko's toes.

Critical design parameters for nanohairs to achieve optimal sticking are hair length, detach angle, distance between nanohairs, and the cross-sectional area of a single strand of hair. By varying these parameters, it is possible to design hairs that can stick to very rough surfaces. At the same time, they must be stiff enough to avoid sticking to each other. Proper material choices help achieving the design goals while providing the required adhesion force. Typically the Young's modulus for materials used in synthetic nanohair vary between 1 GPa and 15 GPa.

Model Definition

This model contains the hierarchy of synthetic gecko foot hair where nanoscale and microscale cantilever beams describe the seta and spatula parts of a spatular stalk attached to a gecko foot. The basis of the analyzed structure is a microscale stalk with the following dimensions: width, 4.53 μm ; height, 4.33 μm ; and length, 75 μm . At the end of the microhair, 169 nanohairs are attached and they have dimensions of 0.18 μm , 0.17 μm , and 3 μm , respectively. The microhair is fixed at the far end, while the contact and friction forces appear as surface loads at the end of each nanohair. The free-body diagram of a micro/nanohair in [Figure 1](#) illustrates the applied forces, which are set to 0.4 μN for the contact force and 0.2 μN for the friction force with 60° contact angle to target surface. The structure is made of β -keratin with a Young's modulus of 2 GPa and a Poisson's ratio of 0.4. The model was inspired by [Ref. 1](#).

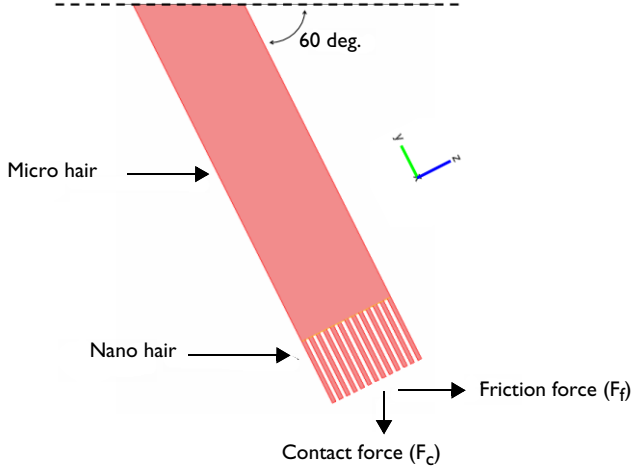

Figure 1: Model of the tip of a gecko foot hair.

Results and Discussion

The plot in Figure 2 shows the von Mises equivalent stress in the model. Table 1 lists the maximum values of the von Mises stress, total displacement, and principal strain:

TABLE 1: STRESS, DISPLACEMENT, AND PRINCIPAL STRAIN RESULTS IGNORING GEOMETRIC NONLINEARITY.

MAXIMUM VON MISES STRESS (N/m ²)	MAXIMUM TOTAL DISPLACEMENT (μm)	MAXIMUM FIRST PRINCIPAL STRAIN
9.52·10 ⁷	12.6	0.0505

The maximum von Mises stress in the analyzed model is almost twice the value of the material's yield stress, which clearly indicates that further investigation is required.

The deformed plot in Figure 2 shows that displacement is large, while the results in the table above indicate that the maximum strain is moderate. Hence, the next step is to enable the geometric nonlinearity within the linear elastic material model. (An alternative would be to search for a suitable hyperelastic material model, which would require the corresponding material data.)

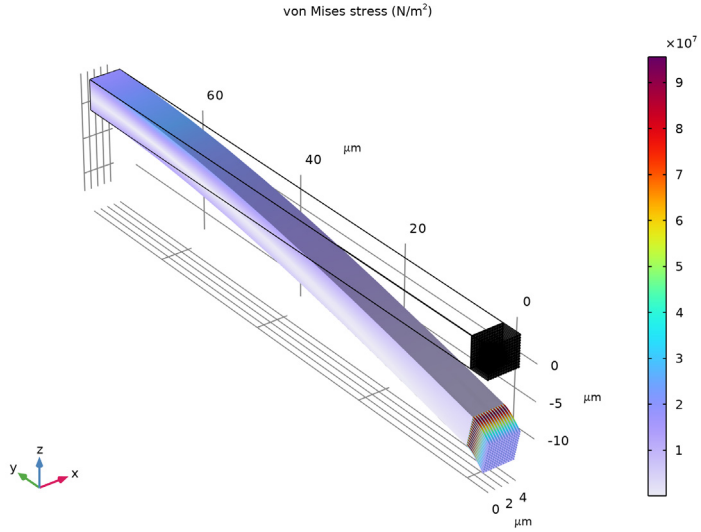

Figure 2: Deformed shape plot of the von Mises stress in a synthetic gecko foot ignoring geometric nonlinearity. The plot shows the displacements without any scaling.

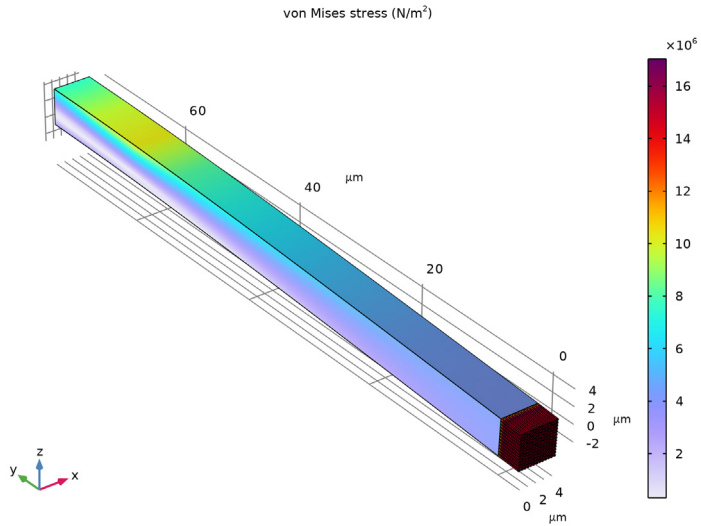

Figure 3: The result recomputed with the geometric nonlinearity taken into account.

You include the geometric nonlinearity by selecting the corresponding checkbox in the Linear Elastic Material Model feature node. The resulting changes in the model equations are shown under the Equation section therein.

The plot in [Figure 3](#) shows the resulting von Mises stress distribution and the deformation, and [Table 2](#) below gives the recomputed maximum values.

TABLE 2: STRESS, DISPLACEMENT, AND PRINCIPAL STRAIN RESULTS INCLUDING GEOMETRIC NONLINEARITY EFFECTS.

MAXIMUM VON MISES STRESS (N/m ²)	MAXIMUM TOTAL DISPLACEMENT (μm)	MAXIMUM FIRST PRINCIPAL STRAIN
$1.73 \cdot 10^7$	2.93	$8.85 \cdot 10^{-3}$

The results show that without the geometric nonlinearity taken into account, the model overpredicts the maximum von Mises stress by more than a factor of five, and the maximum displacement by more than a factor of four. Furthermore, the maximum strain computed with the geometric nonlinearity included becomes less than 1%, which eliminates the need of further analysis involving more complicated hyperelastic material models.

References

1. G. Shah and I. Lee, *Finite Element Analysis of Gecko Foot Hairs for Dry Adhesive Design and Fabrication*, Dept. of Mechanical Engineering — NanoRobotics Lab, Carnegie Mellon Univ., Pittsburgh.
2. M. Sitti and R.S. Fearing, “Synthetic Gecko Foot-Hair Micro/Nano-Structures for Future Wall-Climbing Robots,” *Proc. IEEE Robotics and Automation Conf.*, pp. 1164–1170, 2003.
3. J. Vincent, *Structural Biomaterials*, rev. ed., Princeton University Press, 1990.

Application Library path: MEMS_Module/Actuators/gecko_foot



Modeling Instructions

From the **File** menu, choose **New**.

NEW

In the **New** window, click  **Model Wizard**.

MODEL WIZARD

- 1 In the **Model Wizard** window, click  **3D**.
- 2 In the **Select Physics** tree, select **Structural Mechanics > Solid Mechanics (solid)**.
- 3 Click **Add**.
- 4 Click  **Study**.
- 5 In the **Select Study** tree, select **General Studies > Stationary**.
- 6 Click  **Done**.

GLOBAL DEFINITIONS

Parameters I

- 1 In the **Model Builder** window, under **Global Definitions** click **Parameters I**.
- 2 In the **Settings** window for **Parameters**, locate the **Parameters** section.
- 3 In the table, enter the following settings:

Name	Expression	Value	Description
Fc	0.4[uN]	4E-7 N	Contact force
Ff	0.2[uN]	2E-7 N	Friction force
theta	pi/3	1.0472	Contact angle
Dm	75[um]	7.5E-5 m	Microhair length
Hm	4.33[um]	4.33E-6 m	Microhair width
Wm	4.53[um]	4.53E-6 m	Microhair height
Dn	3[um]	3E-6 m	Nanohair length
Hn	0.17[um]	1.7E-7 m	Nanohair width
Wn	0.18[um]	1.8E-7 m	Nanohair height
Area	Wn*Hn	3.06E-14 m ²	Cross-sectional area of the spatulas

GEOMETRY I

- 1 In the **Model Builder** window, under **Component I (comp1)** click **Geometry I**.
- 2 In the **Settings** window for **Geometry**, locate the **Units** section.
- 3 From the **Length unit** list, choose **µm**.

Nanohair

- 1 In the **Geometry** toolbar, click  **Block**.
- 2 In the **Settings** window for **Block**, locate the **Size and Shape** section.

- 3 In the **Width** text field, type Wn.
- 4 In the **Depth** text field, type Dn.
- 5 In the **Height** text field, type Hn.
- 6 Locate the **Position** section. In the **y** text field, type -Dn.
- 7 In the **Label** text field, type Nanohair.

Next, add object selections for the nanohair's root and end. An object selection is defined by a set of geometric entities at a specified level selected from the geometric objects that precede the object selection feature in the geometry sequence. Their main advantage compared to regular selection features is that object selections propagate through the geometry sequence, which make them robust and convenient to apply in cases like the present one.

Nanohair ends

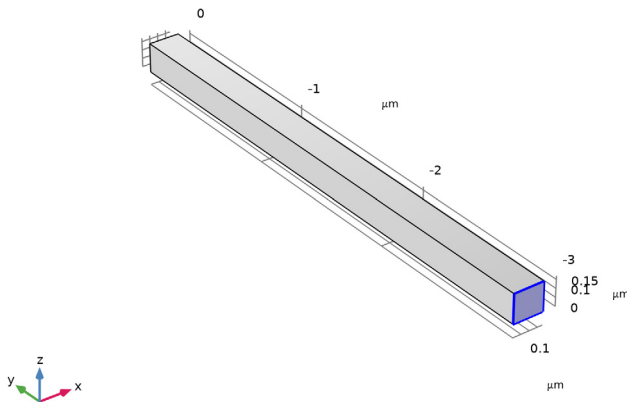

- 1 In the **Geometry** toolbar, click  **Selections** and choose **Explicit Selection**.
- 2 In the **Settings** window for **Explicit Selection**, locate the **Entities to Select** section.
- 3 From the **Geometric entity level** list, choose **Boundary**.
- 4 On the object **blk1**, select Boundary 3 only.





- 5 In the **Label** text field, type Nanohair ends.

Nanohair roots



- 1 In the **Geometry** toolbar, click  **Selections** and choose **Explicit Selection**.

- 2 Click the  **Wireframe Rendering** button in the **Graphics** toolbar.
- 3 In the **Settings** window for **Explicit Selection**, locate the **Entities to Select** section.
- 4 From the **Geometric entity level** list, choose **Boundary**.
- 5 On the object **blk1**, select Boundary 6 only.
- 6 Click the  **Wireframe Rendering** button in the **Graphics** toolbar.
- 7 Click  **Build Selected**.
- 8 In the **Label** text field, type Nanohair roots.

Array 1 (arr1)

- 1 In the **Geometry** toolbar, click  **Transforms** and choose **Array**.
- 2 Select the object **blk1** only.
- 3 In the **Settings** window for **Array**, locate the **Size** section.
- 4 In the **x size** text field, type 13.
- 5 In the **z size** text field, type 13.
- 6 Locate the **Displacement** section. In the **x** text field, type $(Wm - Wn) / 12$.
- 7 In the **z** text field, type $(Hm - Hn) / 12$.
- 8 Click  **Build Selected**.
- 9 Click the  **Zoom Extents** button in the **Graphics** toolbar.

Microhair

- 1 In the **Geometry** toolbar, click  **Block**.
- 2 In the **Settings** window for **Block**, locate the **Size and Shape** section.
- 3 In the **Width** text field, type Wm .
- 4 In the **Depth** text field, type Dm .
- 5 In the **Height** text field, type Hm .
- 6 Click  **Build Selected**.
- 7 In the **Label** text field, type Microhair.

Microhair end

- 1 In the **Geometry** toolbar, click  **Selections** and choose **Explicit Selection**.
- 2 In the **Settings** window for **Explicit Selection**, locate the **Entities to Select** section.
- 3 From the **Geometric entity level** list, choose **Boundary**.

4 On the object **blk2**, select Boundary 3 only.

It might be easier to select the correct boundary by using the **Selection List** window. To open this window, in the **Home** toolbar click **Windows** and choose **Selection List**. (If you are running the cross-platform desktop, you find **Windows** in the main menu.)

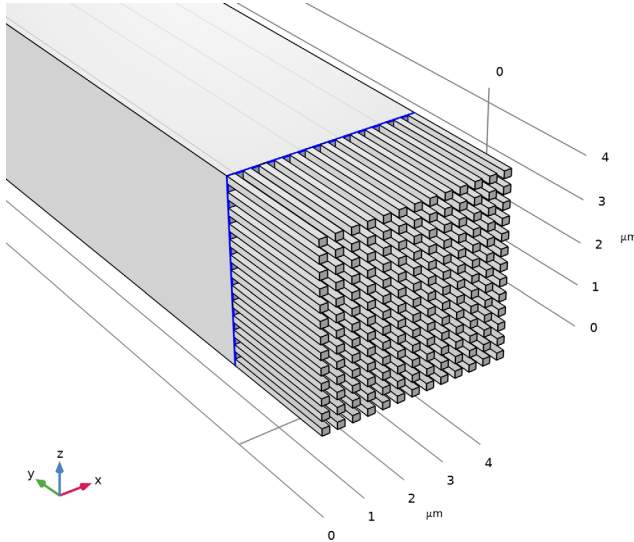

5 Click  **Build Selected**.

6 In the **Label** text field, type **Microhair end**.

7 Click the  **Go to Default View** button in the **Graphics** toolbar.

Form Union (fin)

Use an assembly to connect parts of the geometry of significantly different dimensions.

1 In the **Model Builder** window, under **Component 1 (comp1) > Geometry 1** click **Form Union (fin)**.

2 In the **Settings** window for **Form Union/Assembly**, locate the **Form Union/Assembly** section.

3 From the **Action** list, choose **Form an assembly**.

4 Clear the **Create pairs** checkbox.



5 Click  **Build Selected**.

The model geometry is now complete.

DEFINITIONS

Because of the use of assembly, you need to add an identity pair to set up the displacement field continuity at the interfaces, where the nanohairs are attached to the microhair. Configure the identity to operate on the material frame, because this is the frame used within the **Solid Mechanics** interface.

Identity Boundary Pair 1 (p1)

- 1 In the **Definitions** toolbar, click  **Pairs** and choose **Identity Boundary Pair**.
- 2 In the **Settings** window for **Pair**, locate the **Source Boundaries** section.
- 3 From the **Selection** list, choose **Microhair end**.
- 4 Locate the **Destination Boundaries** section. Click to select the  **Activate Selection** toggle button.
- 5 From the **Selection** list, choose **Nanohair roots**.
- 6 Locate the **Frame** section. From the **Source frame** list, choose **Material (X, Y, Z)**.
- 7 From the **Destination frame** list, choose **Material (X, Y, Z)**.

Define a rotated coordinate system to account for the contact angle.

Rotated System 2 (sys2)

- 1 In the **Definitions** toolbar, click  **Coordinate Systems** and choose **Rotated System**.
- 2 In the **Settings** window for **Rotated System**, locate the **Rotation** section.
- 3 Find the **Euler angles** subsection. In the β text field, type $\pi/2$ -theta.

MATERIALS

Material 1 (mat1)

- 1 In the **Model Builder** window, under **Component 1 (comp1)** right-click **Materials** and choose **Blank Material**.
- 2 In the **Settings** window for **Material**, locate the **Material Contents** section.
- 3 In the table, enter the following settings:

Property	Variable	Value	Unit	Property group
Young's modulus	E	2e9	Pa	Young's modulus and Poisson's ratio
Poisson's ratio	nu	0.4	1	Young's modulus and Poisson's ratio
Density	rho	1200	kg/m ³	Basic

DEFINITIONS

Set up a maximum operator to compute maximum values of the von Mises stress, displacement magnitude, and principal strain over the entire geometry.

Maximum 1 (maxop1)

- 1 In the **Definitions** toolbar, click  **Nonlocal Couplings** and choose **Maximum**.
- 2 In the **Settings** window for **Maximum**, locate the **Source Selection** section.
- 3 From the **Selection** list, choose **All domains**.

Variables 1

- 1 In the **Definitions** toolbar, click  **Local Variables**.
- 2 In the **Settings** window for **Variables**, locate the **Variables** section.
- 3 In the table, enter the following settings:

Name	Expression	Unit	Description
max_v_Mises	maxop1(solid.mises)	N/m ²	Maximum von Mises stress
max_disp	maxop1(solid.disp)	m	Maximum displacement magnitude
max_ep1	maxop1(solid.ep1)		Maximum first principal strain

SOLID MECHANICS (SOLID)

Fixed Constraint 1

- 1 In the **Physics** toolbar, click  **Boundaries** and choose **Fixed Constraint**.
- 2 Select Boundary 83 only.

Boundary Load 1

- 1 In the **Physics** toolbar, click  **Boundaries** and choose **Boundary Load**.
- 2 In the **Settings** window for **Boundary Load**, locate the **Boundary Selection** section.
- 3 From the **Selection** list, choose **Nanohair ends**.
- 4 Locate the **Coordinate System Selection** section. From the **Coordinate system** list, choose **Rotated System 2 (sys2)**.
- 5 Locate the **Force** section. Specify the \mathbf{f}_A vector as

0	x1
-Fc/Area	x2
Ff/Area	x3

Continuity 1a

- 1 In the **Physics** toolbar, click  **Pairs** and choose **Continuity**.
- 2 In the **Settings** window for **Continuity**, locate the **Pair Selection** section.
- 3 Click **+ Add**.
- 4 In the **Add** dialog, select **Identity Boundary Pair 1 (p1)** in the **Pairs** list.
- 5 Click **OK**.

MESH 1

Mapped 1

- 1 In the **Mesh** toolbar, click  **More Generators** and choose **Mapped**.
- 2 In the **Settings** window for **Mapped**, locate the **Boundary Selection** section.
- 3 From the **Selection** list, choose **Nanohair ends**.

Size 1

- 1 Right-click **Mapped 1** and choose **Size**.
- 2 In the **Settings** window for **Size**, locate the **Element Size** section.
- 3 Click the **Custom** button.
- 4 Locate the **Element Size Parameters** section.
- 5 Select the **Maximum element size** checkbox. In the associated text field, type 0.1.

Mapped 1

In the **Model Builder** window, right-click **Mapped 1** and choose **Build Selected**.

Swept 1

- 1 In the **Mesh** toolbar, click  **Swept**.
- 2 In the **Settings** window for **Swept**, locate the **Domain Selection** section.
- 3 From the **Geometric entity level** list, choose **Domain**.
- 4 From the **Selection** list, choose **All domains**.
- 5 Remove Domain 14 from the selection.

Distribution 1

Right-click **Swept 1** and choose **Distribution**.

Swept 1

In the **Model Builder** window, right-click **Swept 1** and choose **Build Selected**.

Mapped 2

- 1 In the **Mesh** toolbar, click  **More Generators** and choose **Mapped**.
- 2 Select Boundary 83 only.

Distribution 1

- 1 Right-click **Mapped 2** and choose **Distribution**.
- 2 Select Edges 162–164 and 168 only.

Mapped 2

In the **Model Builder** window, right-click **Mapped 2** and choose **Build Selected**.

Swept 2

In the **Mesh** toolbar, click  **Swept**.

Distribution 1

- 1 Right-click **Swept 2** and choose **Distribution**.
- 2 Right-click **Distribution 1** and choose **Build Selected**.

The mesh is now complete.

STUDY 1

In the **Study** toolbar, click  **Compute**.



RESULTS

Stress (solid)

Reproduce the plot in [Figure 2](#) by following these steps:

- 1 In the **Model Builder** window, expand the **Stress (solid)** node.



Deformation

- 1 In the **Model Builder** window, expand the **Results > Stress (solid) > Volume 1** node, then click **Deformation**.
- 2 In the **Settings** window for **Deformation**, locate the **Scale** section.
- 3 Select the **Scale factor** checkbox. In the associated text field, type 1.
- 4 In the **Stress (solid)** toolbar, click  **Plot**.
- 5 Click the  **Zoom Extents** button in the **Graphics** toolbar.



Compare the resulting plot to that in [Figure 2](#).

Next, calculate the maximum values for von Mises stress, displacement magnitude, and first principal strain; compare the results to those shown in [Table 1](#).



Global Evaluation 1

- 1 In the **Results** toolbar, click  **Global Evaluation**.
- 2 In the **Settings** window for **Global Evaluation**, click **Replace Expression** in the upper-right corner of the **Expressions** section. From the menu, choose **Component 1 (comp1) > Definitions > Variables > max_v_Mises - Maximum von Mises stress - N/m²**.
- 3 Click  **Evaluate**.

Global Evaluation 2

- 1 In the **Results** toolbar, click  **Global Evaluation**.
- 2 In the **Settings** window for **Global Evaluation**, click **Replace Expression** in the upper-right corner of the **Expressions** section. From the menu, choose **Component 1 (comp1) > Definitions > Variables > max_disp - Maximum displacement magnitude - m**.
- 3 Click  next to  **Evaluate**, then choose **Table 1 - Global Evaluation 1**.

Global Evaluation 3

- 1 In the **Results** toolbar, click  **Global Evaluation**.
- 2 In the **Settings** window for **Global Evaluation**, click **Replace Expression** in the upper-right corner of the **Expressions** section. From the menu, choose **Component 1 (comp1) > Definitions > Variables > max_ep1 - Maximum first principal strain - 1**.
- 3 Click  next to  **Evaluate**, then choose **Table 1 - Global Evaluation 1**.

SOLID MECHANICS (SOLID)

Linear Elastic Material 1

Now, switch on geometric nonlinearity.

STUDY 1

Step 1: Stationary

- 1 In the **Model Builder** window, under **Study 1** click **Step 1: Stationary**.
- 2 In the **Settings** window for **Stationary**, locate the **Study Settings** section.
- 3 Select the **Include geometric nonlinearity** checkbox.
- 4 In the **Study** toolbar, click  **Compute**.

RESULTS

Stress (solid)

Compare the plot in the **Graphics** window with that in [Figure 3](#).

Global Evaluation 1

Finally, compute the new maximum values and display them in a new table. Compare the results to those in [Table 2](#).

- I In the **Model Builder** window, under **Results > Derived Values** right-click **Global Evaluation 1** and choose **Evaluate > New Table**.

Global Evaluation 2

In the **Model Builder** window, right-click **Global Evaluation 2** and choose **Evaluate > Table 2 - Global Evaluation 1**.

Global Evaluation 3

In the **Model Builder** window, right-click **Global Evaluation 3** and choose **Evaluate > Table 2 - Global Evaluation 1**.