



Model created in COMSOL Multiphysics 6.4

# Electrostatically Actuated Cantilever

## *Introduction*

---

The elastic cantilever beam is an elementary structure in MEMS design. This example shows the bending of a beam due to electrostatic forces. The model uses the **Electromechanics** multiphysics interface to solve the coupled equations for the structural deformation and the electric field. Such structures are frequently tested by means of a low frequency capacitance voltage sweep. The model predicts the results of such a test.

## *Model Definition*

---

[Figure 1](#) shows the model geometry. The beam has the following dimensions:

- Length: 300  $\mu\text{m}$
- Width: 20  $\mu\text{m}$
- Thickness 2  $\mu\text{m}$

Because the geometry is symmetric, only half of the beam needs to modeled. The beam is made of polysilicon with a Young's modulus,  $E$ , of 153 GPa, and a Poisson's ratio,  $\nu$ , of 0.23. It is fixed at one end but is otherwise free to move. The polysilicon is assumed to be heavily doped, so that electric field penetration into the structure can be neglected. In this case, the **Domain Terminal** feature can be used to set up the Si domain. The beam resides in an air-filled chamber that is electrically insulated. The lower side of the chamber has a grounded electrode.

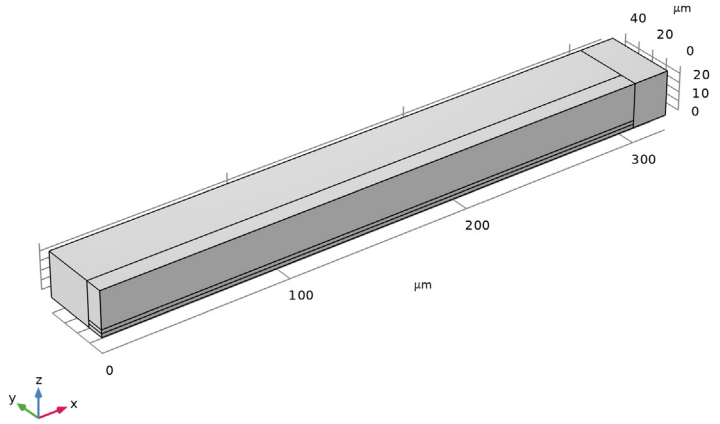

*Figure 1: Model Geometry. The beam is 300  $\mu\text{m}$  long and 2  $\mu\text{m}$  thick, and it is fixed at  $x = 0$ . The model uses symmetry on the  $zx$ -plane at  $y = 0$ . The lower boundary of the surrounding air domain represents the grounded substrate. The model has 20  $\mu\text{m}$  of free air above and to the sides of the beam, while the gap below the beam is 2  $\mu\text{m}$ .*

An electrostatic force caused by an applied potential difference between the two electrodes bends the beam toward the grounded plane beneath it. To compute the electrostatic force, this example calculates the electric field in the surrounding air. The model considers a layer of air 20  $\mu\text{m}$  thick both above and to the sides of the beam, and the air gap between the bottom of the beam and the grounded layer is initially 2  $\mu\text{m}$ . As the beam bends, the geometry of the air gap changes continuously, resulting in a change in the electric field between the electrodes. The coupled physics is handled automatically by the **Electromechanics** multiphysics interface.

The electrostatic field in the air and in the beam is governed by Poisson's equation:

$$-\nabla \cdot (\epsilon \nabla V) = 0$$

where derivatives are taken with respect to the spatial coordinates. The numerical model represents the electric potential and its derivatives on a mesh which is moving with respect to the spatial frame. The necessary transformations are taken care of by the **Electromechanics** multiphysics interface, which also contains smoothing equations governing the movement of the mesh in the air domain.

The cantilever connects to a voltage terminal with a specified bias potential,  $V_{\text{in}}$ . The bottom of the chamber is grounded, while all other boundaries are electrically insulated. The terminal boundary condition automatically computes the capacitance of the system.

The force density that acts on the electrode of the beam results from Maxwell's stress tensor:

$$\mathbf{F}_{\text{es}} = -\frac{1}{2}(\mathbf{E} \cdot \mathbf{D})\mathbf{n} + (\mathbf{n} \cdot \mathbf{E})\mathbf{D}$$

where  $\mathbf{E}$  and  $\mathbf{D}$  are the electric field and electric displacement vectors, respectively, and  $\mathbf{n}$  is the outward normal vector of the boundary. This force is always oriented along the normal of the boundary.

Navier's equations, which govern the deformation of a solid, are more conveniently written in a coordinate system that follows and deforms with the material. In this case, these reference or material coordinates are identical to the actual mesh coordinates.

## *Results and Discussion*

---

There is positive feedback between the electrostatic forces and the deformation of the cantilever beam. The forces bend the beam and thereby reduce the gap to the grounded substrate. This action, in turn, increases the forces. At a certain voltage the electrostatic forces overcome the stress forces, the system becomes unstable, and the gap collapses. This critical voltage is called the *pull-in voltage*.

At applied voltages lower than the pull-in voltage, the beam stays in an equilibrium position where the stress forces balance the electrostatic forces. [Figure 2](#) shows the beam displacement and the corresponding displacement of the mesh surrounding it. [Figure 3](#) shows the electric potential and electric field that generates these displacements. In [Figure 4](#) the shape of the cantilever's deflection is illustrated for each applied voltage, by plotting the z-displacement of the underside of the beam at the symmetry boundary. The tip deflection as a function of applied voltage is shown in [Figure 5](#). Note that for applied voltages higher than the pull-in voltage, the solution does not converge because no stable stationary solution exists. This situation occurs if an applied voltage of 6.2 V is tried. The pull-in voltage is therefore between 6.1 V and 6.2 V. For comparison, computations in [Ref. 1](#) predict a pull-in voltage of

$$V_{\text{PI}} = \sqrt{\frac{4c_1 B}{\epsilon_0 L^4 c_2^2 \left(1 + c_3 \frac{g_0}{W}\right)}}$$

where  $c_1 = 0.07$ ,  $c_2 = 1.00$ , and  $c_3 = 0.42$ ;  $g_0$  is the initial gap between the beam and the ground plane; and

$$B = \hat{E}H^3g_0^3$$

If the beam has a narrow width ( $W$ ) relative to its thickness ( $H$ ) and length ( $L$ ),  $\hat{E}$  is Young's modulus,  $E$ . Otherwise,  $E$  and  $\hat{E}$ , the plate modulus, are related by

$$\frac{E}{\hat{E}} \approx 1 - \nu^2 \left( \frac{(W/L)^{1,37}}{0,5 + (W/L)^{1,37}} \right)^{0,98(L/H)^{-0,056}}$$

where  $\nu$  is Poisson's ratio. Because the calculation in [Ref. 1](#) uses a parallel-plate approximation for calculating the electrostatic force and because it corrects for fringing fields, these results are not directly comparable with those from the simulation. However the agreement is still reasonable: setting  $W = 20 \mu\text{m}$  results in  $V_{PI} = 6.07 \text{ V}$ .

V0(8)=6.1 V Volume: Displacement field, Z-component ( $\mu\text{m}$ ) Slice: Spatial mesh displacement z ( $\mu\text{m}$ )

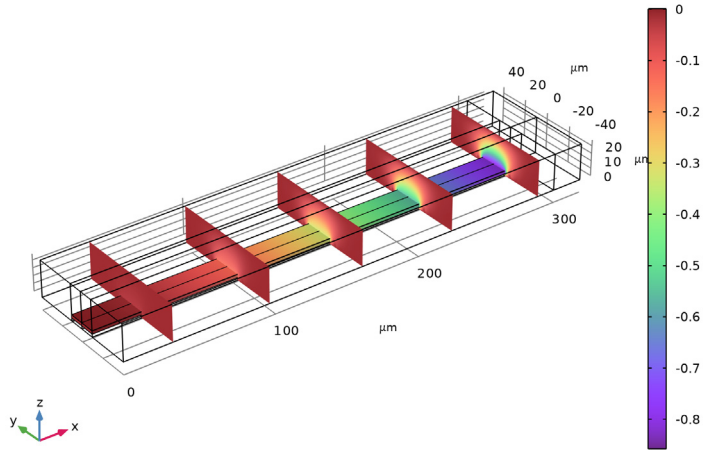

Figure 2: z-displacement for the beam and the moving mesh as a function of position. Each mesh element is depicted as a separate block in the back half of the geometry.

V0(8)=6.1 V

Electric potential (V)

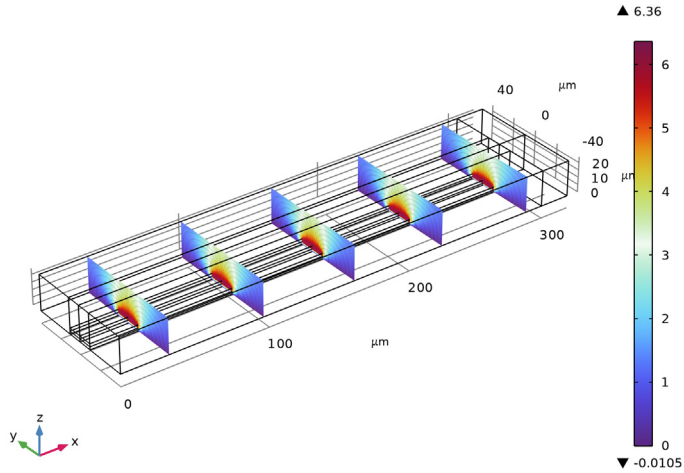

Figure 3: Electric Potential (color) and Electric Field (arrows) at various cross sections through the beam.

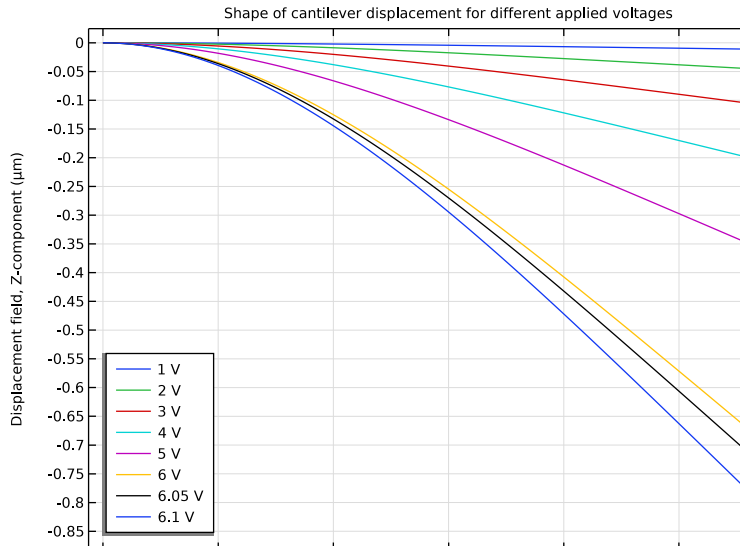

Figure 4: Displacement of the lower surface of the cantilever, plotted along the symmetry boundary, for different values of the applied voltage.

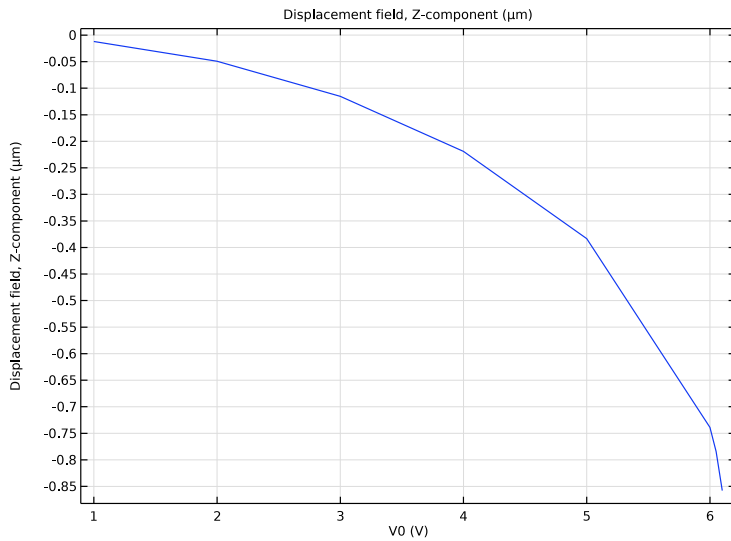

Figure 5: Cantilever tip displacements as a function of applied Voltage  $V_0$ .

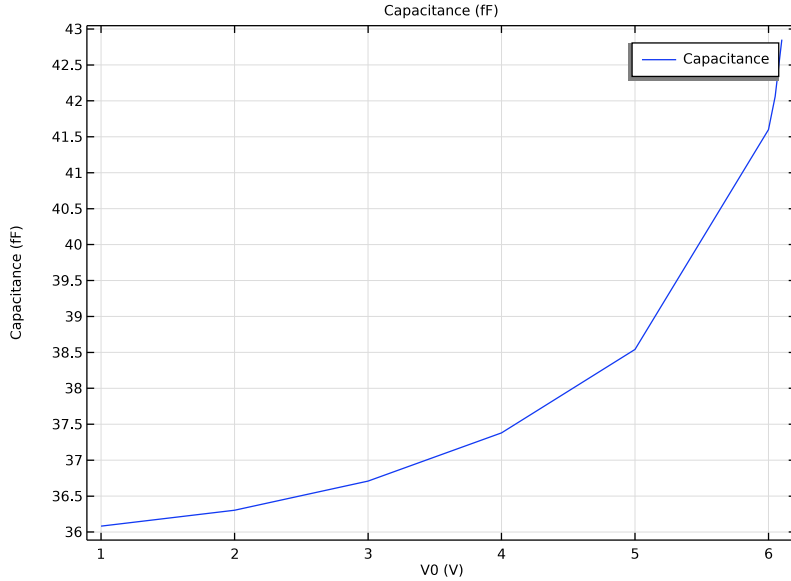

Figure 6: Device capacitance vs applied voltage  $V_0$ .

Figure 6 shows the DC C-V curve predicted for the cantilever beam. To some extent, this is consistent with the behavior of an ideal parallel plate capacitor, whose capacitance increases with decreasing distance between the plates. But this effect does not account for all the change in capacitance observed. In fact, most of it is due to the gradual softening of the coupled electromechanical system. This effect leads to a larger structural response for a given voltage increment at higher bias, which in turn means that more charge must be added to retain the voltage difference between the electrodes.

### Reference

---

1. R.K. Gupta, *Electrostatic Pull-In Structure Design for In-Situ Mechanical Property Measurements of Microelectromechanical Systems (MEMS)*, PhD thesis, MIT, 1997.

---

**Application Library path:** MEMS\_Module/Actuators/  
electrostatically\_actuated\_cantilever

---

## Modeling Instructions



---

From the **File** menu, choose **New**.

### NEW

In the **New** window, click  **Model Wizard**.

### MODEL WIZARD



- 1 In the **Model Wizard** window, click  **3D**.
- 2 In the **Select Physics** tree, select **Structural Mechanics > Electromagnetics–Structure Interaction > Electromechanics > Electromechanics, Solid**.
- 3 Click **Add**.
- 4 Click  **Study**.
- 5 In the **Select Study** tree, select **General Studies > Stationary**.
- 6 Click  **Done**.

### GEOMETRY I

Use microns to define the geometry units.

- 1 In the **Model Builder** window, under **Component 1 (comp1)** click **Geometry 1**.
- 2 In the **Settings** window for **Geometry**, locate the **Units** section.
- 3 From the **Length unit** list, choose **μm**.  
Create two blocks to represent the cantilever and air domains, respectively.

#### Block 1 (blk1)

- 1 In the **Geometry** toolbar, click  **Block**.
- 2 In the **Settings** window for **Block**, locate the **Size and Shape** section.
- 3 In the **Width** text field, type 300.
- 4 In the **Depth** text field, type 10.
- 5 In the **Height** text field, type 2.
- 6 Locate the **Position** section. In the **z** text field, type 2.
- 7 Click  **Build Selected**.

#### Block 2 (blk2)

- 1 In the **Geometry** toolbar, click  **Block**.
- 2 In the **Settings** window for **Block**, locate the **Size and Shape** section.
- 3 In the **Width** text field, type 320.

4 In the **Depth** text field, type 40.

5 In the **Height** text field, type 24.

Add two more blocks to simplify meshing of the geometry.

#### *Block 3 (blk3)*

1 In the **Geometry** toolbar, click  **Block**.

2 In the **Settings** window for **Block**, locate the **Size and Shape** section.

3 In the **Width** text field, type 20.

4 In the **Depth** text field, type 40.

5 In the **Height** text field, type 24.

6 Locate the **Position** section. In the **x** text field, type 300.

#### *Block 4 (blk4)*

1 In the **Geometry** toolbar, click  **Block**.

2 In the **Settings** window for **Block**, locate the **Size and Shape** section.

3 In the **Width** text field, type 300.

4 In the **Depth** text field, type 10.

5 In the **Height** text field, type 24.

6 Click  **Build All Objects**.

Add a parameter for the DC voltage applied to the cantilever.

## **GLOBAL DEFINITIONS**

### *Parameters 1*

1 In the **Model Builder** window, under **Global Definitions** click **Parameters 1**.

2 In the **Settings** window for **Parameters**, locate the **Parameters** section.

3 In the table, enter the following settings:

<b>Name</b>	<b>Expression</b>	<b>Value</b>	<b>Description</b>
V0	5[V]	5 V	Bias on cantilever

The cantilever is assumed to be heavily doped so that it acts as a conductor, held at constant potential. The **Linear Elastic Material** feature is therefore used.



## **SOLID MECHANICS (SOLID)**

1 In the **Model Builder** window, under **Component 1 (comp1)** click **Solid Mechanics (solid)**.

2 Select Domain 2 only.

## DEFINITIONS

*Air*

- 1 In the **Definitions** toolbar, click  **Explicit**.
- 2 In the **Settings** window for **Explicit**, locate the **Input Entities** section.
- 3 Click  **Paste Selection**.
- 4 In the **Paste Selection** dialog, type 1,3,4,5 in the **Selection** text field.
- 5 Click **OK**.
- 6 In the **Settings** window for **Explicit**, type Air in the **Label** text field.

## MOVING MESH

*Deforming Domain 1*

- 1 In the **Model Builder** window, under **Component 1 (comp1) > Moving Mesh** click **Deforming Domain 1**.
- 2 In the **Settings** window for **Deforming Domain**, locate the **Domain Selection** section.
- 3 From the **Selection** list, choose **Air**.  
Fix one end of the cantilever.

## SOLID MECHANICS (SOLID)

*Fixed Constraint 1*

- 1 In the **Physics** toolbar, click  **Boundaries** and choose **Fixed Constraint**.
- 2 Select Boundary 4 only.

Since only half of the cantilever is included in the model, the symmetry condition should be applied on the midplane of the solid. The electric field default condition (**Zero Charge**) is equivalent to a symmetry condition, so only the structural symmetry boundary condition needs to be applied.

*Symmetry 1*

- 1 In the **Physics** toolbar, click  **Boundaries** and choose **Symmetry**.
- 2 Select Boundary 5 only.

## MOVING MESH

*Symmetry/Roller 1*

- 1 In the **Model Builder** window, under **Component 1 (comp1) > Moving Mesh** click **Symmetry/Roller 1**.

2 Select Boundaries 2, 8, and 19 only.

Use the **Domain Terminal** feature to set the voltage of the cantilever. Note: The **Domain Terminal** feature will be very handy for a conducting domain with a complex shape and many exterior boundaries - instead of selecting all the boundaries to set up the ground, terminal, or electric potential boundary condition, we only need to select the domain to specify the **Domain Terminal** with the same effect. In addition, the computation load is reduced, because the electrostatic degrees of freedom within the **Domain Terminal** do not need to be solved for.

## ELECTROSTATICS (ES)

### *Charge Conservation in Solids I*

In the **Model Builder** window, under **Component 1 (comp1) > Electrostatics (es)** right-click **Charge Conservation in Solids I** and choose **Delete**.

### *Domain Terminal I*

1 In the **Physics** toolbar, click  **Domains** and choose **Domain Terminal**.

2 Select Domain 2 only.

3 In the **Settings** window for **Domain Terminal**, locate the **Terminal** section.

4 From the **Terminal type** list, choose **Voltage**.

5 In the  $V_0$  text field, type  $V_0$ .

Set up the ground plane underneath the cantilever.

### *Ground I*

1 In the **Physics** toolbar, click  **Boundaries** and choose **Ground**.

2 Select Boundaries 3 and 13 only.

Add Materials to the model.

## MATERIALS

### *Material 1 (mat1)*

1 In the **Model Builder** window, under **Component 1 (comp1)** right-click **Materials** and choose **Blank Material**.

2 Select Domain 2 only.

3 In the **Settings** window for **Material**, locate the **Material Contents** section.

4 In the table, enter the following settings:

Property	Variable	Value	Unit	Property group
Young's modulus	E	153 [ GPa ]	Pa	Young's modulus and Poisson's ratio
Poisson's ratio	nu	0.23	l	Young's modulus and Poisson's ratio
Density	rho	2330	kg/m <sup>3</sup>	Basic

## MESH 1

### *Mapped 1*

1 In the **Mesh** toolbar, click  **More Generators** and choose **Mapped**.

2 Select Boundaries 1, 4, and 7 only.

### *Distribution 1*

1 Right-click **Mapped 1** and choose **Distribution**.

2 Select Edges 1, 2, 4, 5, 8, 12, and 15 only.

3 In the **Settings** window for **Distribution**, locate the **Distribution** section.

4 In the **Number of elements** text field, type 2.

### *Distribution 2*

1 In the **Model Builder** window, right-click **Mapped 1** and choose **Distribution**.

2 Select Edges 7 and 17 only.

3 In the **Settings** window for **Distribution**, click  **Build Selected**.

### *Copy Edge 1*

1 In the **Model Builder** window, right-click **Mesh 1** and choose **Copying Operations > Copy Edge**.

2 Select Edges 12, 15, and 17 only.

3 In the **Settings** window for **Copy Edge**, locate the **Destination Edges** section.

4 Click to select the  **Activate Selection** toggle button.

5 Select Edge 21 only.

6 Click  **Build Selected**.

### *Mapped 2*

1 In the **Mesh** toolbar, click  **More Generators** and choose **Mapped**.

2 Select Boundary 11 only.

### *Distribution 1*

- 1 Right-click **Mapped 2** and choose **Distribution**.
- 2 Select Edges 13 and 19 only.
- 3 In the **Settings** window for **Distribution**, click  **Build Selected**.

### *Swept 1*

In the **Mesh** toolbar, click  **Swept**.

### *Distribution 1*

- 1 Right-click **Swept 1** and choose **Distribution**.
- 2 Select Domains 1–4 only.
- 3 In the **Settings** window for **Distribution**, locate the **Distribution** section.
- 4 In the **Number of elements** text field, type 15.



### *Distribution 2*

- 1 In the **Model Builder** window, right-click **Swept 1** and choose **Distribution**.
- 2 Select Domain 5 only.
- 3 In the **Settings** window for **Distribution**, locate the **Distribution** section.
- 4 In the **Number of elements** text field, type 1.
- 5 Click  **Build All**.

Set up a **Parametric Sweep** over the applied voltage.

## **STUDY 1**

### *Step 1: Stationary*

- 1 In the **Model Builder** window, under **Study 1** click **Step 1: Stationary**.
- 2 In the **Settings** window for **Stationary**, click to expand the **Study Extensions** section.
- 3 Select the **Auxiliary sweep** checkbox.
- 4 Click  **Add**.
- 5 Click  **Range**.
- 6 In the **Range** dialog, type 1 in the **Start** text field.
- 7 In the **Step** text field, type 1.
- 8 In the **Stop** text field, type 6.
- 9 Click **Add**.

Add points at 6.05 and 6.1 V to the sweep by adding these points after the range statement. The table field should now contain: range(1,1,6) 6.05 6.1.

10 In the **Study** toolbar, click  **Compute**.

## RESULTS

### *Displacement (solid)*

Create a mirrored dataset for postprocessing.

#### *Mirror 3D 1*

1 In the **Results** toolbar, click  **More Datasets** and choose **Mirror 3D**.

2 In the **Settings** window for **Mirror 3D**, locate the **Plane Data** section.

3 From the **Plane** list, choose **zx-planes**.

Edit the first default plot to show the  $z$ -displacement and the corresponding mesh deformation.

### *Vertical displacement (solid)*

1 In the **Model Builder** window, under **Results** click **Displacement (solid)**.

2 In the **Settings** window for **3D Plot Group**, type Vertical displacement (solid) in the **Label** text field.

3 Locate the **Data** section. From the **Dataset** list, choose **Mirror 3D 1**.

### *Volume 1*

1 In the **Model Builder** window, expand the **Vertical displacement (solid)** node, then click **Volume 1**.

2 In the **Settings** window for **Volume**, locate the **Expression** section.

3 In the **Expression** text field, type  $w$ .

### *Slice 1*

1 In the **Model Builder** window, right-click **Vertical displacement (solid)** and choose **Slice**.

2 In the **Settings** window for **Slice**, locate the **Expression** section.

3 In the **Expression** text field, type  $\text{spatial.w}$ .

4 Click to expand the **Inherit Style** section. From the **Plot** list, choose **Volume 1**.

5 In the **Vertical displacement (solid)** toolbar, click  **Plot**.

Edit the second default potential plot.

### *Electric Potential (es)*

1 In the **Model Builder** window, under **Results** click **Electric Potential (es)**.

2 In the **Settings** window for **3D Plot Group**, locate the **Data** section.

3 From the **Dataset** list, choose **Mirror 3D 1**.

### *Multislice 1*

- 1 In the **Model Builder** window, expand the **Electric Potential (es)** node, then click **Multislice 1**.
- 2 In the **Settings** window for **Multislice**, locate the **Multipane Data** section.
- 3 Find the **x-planes** subsection. From the **Entry method** list, choose **Number of planes**.
- 4 In the **Planes** text field, type 5.
- 5 Find the **y-planes** subsection. From the **Entry method** list, choose **Number of planes**.
- 6 In the **Planes** text field, type 0.
- 7 Find the **z-planes** subsection. From the **Entry method** list, choose **Number of planes**.
- 8 In the **Planes** text field, type 0.

### *Streamline Multislice 1*

- 1 In the **Model Builder** window, click **Streamline Multislice 1**.
- 2 In the **Settings** window for **Streamline Multislice**, locate the **Multipane Data** section.
- 3 Find the **x-planes** subsection. From the **Entry method** list, choose **Number of planes**.
- 4 In the **Planes** text field, type 5.
- 5 Find the **y-planes** subsection. From the **Entry method** list, choose **Number of planes**.
- 6 In the **Planes** text field, type 0.
- 7 Find the **z-planes** subsection. From the **Entry method** list, choose **Number of planes**.
- 8 In the **Planes** text field, type 0.
- 9 Locate the **Streamline Positioning** section. In the **Density level** text field, type 5.8.
- 10 In the **Electric Potential (es)** toolbar, click  **Plot**.  
Add a plot to show the deformed shape of the underside of the cantilever.

### *ID Plot Group 5*

In the **Results** toolbar, click  **ID Plot Group**.

### *Line Graph 1*

- 1 Right-click **ID Plot Group 5** and choose **Line Graph**.
- 2 Select Edge 6 only.
- 3 In the **Settings** window for **Line Graph**, click **Replace Expression** in the upper-right corner of the **y-Axis Data** section. From the menu, choose **Component 1 (comp1) > Solid Mechanics > Displacement > Displacement field - m > w - Displacement field, Z-component**.
- 4 Click to expand the **Legends** section. Select the **Show legends** checkbox.

### *Displacement vs. Applied Voltage*

- 1 In the **Model Builder** window, click **ID Plot Group 5**.
- 2 In the **Settings** window for **ID Plot Group**, locate the **Legend** section.
- 3 From the **Position** list, choose **Lower left**.
- 4 Click to expand the **Title** section. From the **Title type** list, choose **Manual**.
- 5 In the **Title** text area, type Shape of cantilever displacement for different applied voltages.
- 6 In the **Label** text field, type Displacement vs. Applied Voltage.
- 7 In the **Displacement vs. Applied Voltage** toolbar, click  **Plot**.  
Add a plot of tip displacement versus applied DC voltage.

### *ID Plot Group 6*

In the **Results** toolbar, click  **ID Plot Group**.

### *Point Graph 1*

- 1 Right-click **ID Plot Group 6** and choose **Point Graph**.
- 2 Select Point 12 only.
- 3 In the **Settings** window for **Point Graph**, click **Replace Expression** in the upper-right corner of the **y-Axis Data** section. From the menu, choose **Component 1 (comp1) > Solid Mechanics > Displacement > Displacement field - m > w - Displacement field, Z-component**.

### *Tip Displacement vs. Applied Voltage*

- 1 In the **Model Builder** window, under **Results** click **ID Plot Group 6**.
- 2 In the **Settings** window for **ID Plot Group**, type Tip Displacement vs. Applied Voltage in the **Label** text field.
- 3 In the **Tip Displacement vs. Applied Voltage** toolbar, click  **Plot**.  
Finally, plot the DC capacitance of the device versus voltage.

### *ID Plot Group 7*

In the **Results** toolbar, click  **ID Plot Group**.

### *Global 1*

- 1 Right-click **ID Plot Group 7** and choose **Global**.

- 2 In the **Settings** window for **Global**, click **Replace Expression** in the upper-right corner of the **y-Axis Data** section. From the menu, choose **Component 1 (comp1) > Electrostatics > Terminals > es.C11 - Maxwell capacitance - F**.

Modify the automatically generated expression to account for the symmetry boundary condition.

- 3 Locate the **y-Axis Data** section. In the table, enter the following settings:

Expression	Unit	Description
2*es.C11	fF	Capacitance

#### *DC C-V Curve*

- 1 In the **Model Builder** window, under **Results** click **ID Plot Group 7**.
- 2 In the **Settings** window for **ID Plot Group**, type DC C-V Curve in the **Label** text field.
- 3 In the **DC C-V Curve** toolbar, click  **Plot**.