



Model created in COMSOL Multiphysics 6.4

# Capacitive Micromachined Ultrasonic Transducer

## *Introduction*

---

A capacitive micromachined ultrasonic transducer (CMUT) is a microscale transmitter-receiver that converts an electrical signal to ultrasound or vice versa for high-resolution imaging applications. This model analyzes a CMUT receiver with a novel piston-shaped electrode and suspended mass design that optimizes force-displacement characteristics for increased efficiency. The improvement is reflected in the increase of the *displacement uniformity factor*, which can be calculated using a **Frequency Domain, Prestressed** study. CMUT technology in general improves upon a well-established medical imaging technology dominated by piezoelectric transducers and promises miniaturization and higher resolution.

## *Model Definition*

---

The device is based on the work reported in [Ref. 1](#). It can be fabricated using well-established  $0.35\ \mu\text{m}$  CMOS-MEMS process technology. On a silicon substrate, alternating layers of dielectric (silicon dioxide) and metal (aluminum) are deposited and lithographically patterned in sequence. All dielectric and metal thicknesses are  $1.0\ \mu\text{m}$  and  $0.64\ \mu\text{m}$ , respectively, except for the topmost metal layer which is  $1.28\ \mu\text{m}$ . There are three dielectric layers, four metal layers, and one final passivation layer (silicon nitride) which is  $1.0\ \mu\text{m}$ . The passivation layer serves as a membrane that can respond to external pressure and protects the device from the external environment. After the deposition steps are completed, a selective and isotropic etching process removes the sacrificial material to release the membrane and the suspended mass.

The model is a 3D model of one quadrant of the device. Because of its four-fold symmetry and the analyses needed, it is not necessary to explicitly model the entire device. [Figure 1](#) shows the piston-shaped electrode within the suspended mass and connected to the membrane. The model comprises dielectric, metal, and passivation layers. The dimensions of the geometric model are:

- Length:  $31.75\ \mu\text{m}$  (half the length of the device)
- Height:  $6.56\ \mu\text{m}$

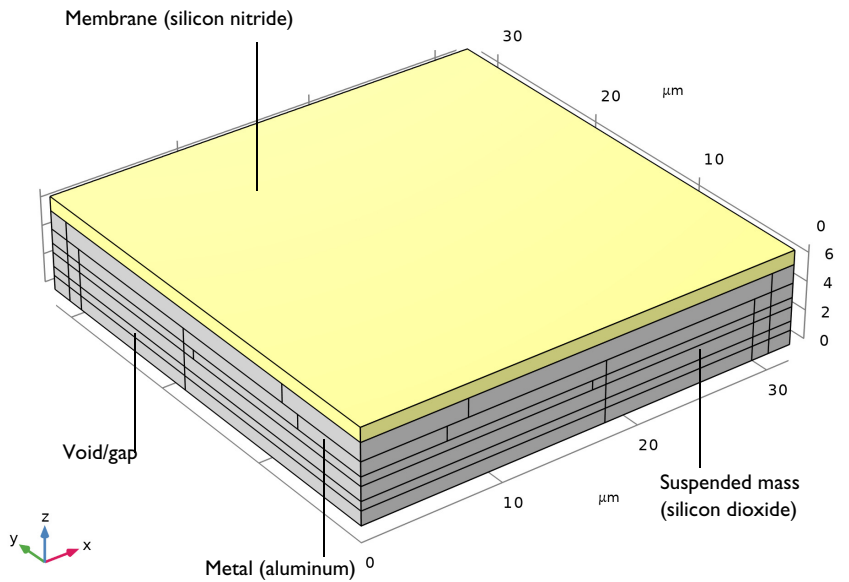

*Figure 1: The model of one quadrant of the device. This 3D plot shows the materials used in the model. The membrane is silicon nitride (yellow), the top electrode and supports are metal (red), and the suspended mass is silicon dioxide (blue). The void or gap is shown in gray.*

Figure 2 shows the boundary conditions. The ground plane is represented by a **Ground** boundary condition. The first layer of silicon dioxide is deposited over the ground plane. The gap is defined by the thickness of the sacrificial metal layer. Embedded within the suspended mass is the electrode plate connected to the silicon nitride membrane/passivation layer. As the membrane is deflected by an external pressure differential, the gap between the electrodes changes. The external stimulation is represented by a **Boundary Load** feature with **Harmonic Perturbation** enabled. This condition is applied to the top surface of the membrane. With a bias of 5 V between the electrodes, the change in capacitance will be reflected in the output current.

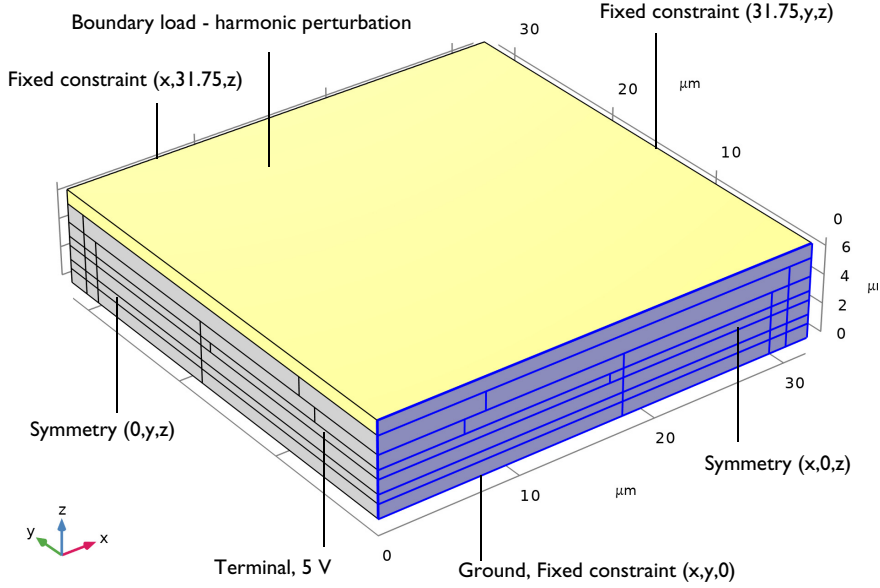

Figure 2: This 3D plot shows boundary conditions used in the model. At the bottom surface of the model is Ground plate and top electrode is set to 5 V. Applied to the top surface is the Boundary Load using a Harmonic Perturbation.

In general the amplified output voltage,  $V_{\text{out}}$ , of the CMUT is given by

$$V_{\text{out}} = \left[ \frac{C_{\text{CMUT}}}{h_{1\text{MD}}/\epsilon_r + d_0} V_{\text{P}} \right] \cdot \frac{A_{\text{BF}}}{C_{\text{F}}} \cdot \Delta d_{\text{avg}}$$

where  $C_{\text{CMUT}}$  is the static capacitance of the device,  $h_{1\text{MD}}$  is the total thickness of the dielectric between the electrodes,  $\epsilon_r$  is the permittivity of the dielectric,  $d_0$  is the capacitor gap,  $V_{\text{P}}$  is the DC bias,  $A_{\text{BF}}$  is the gain of the buffer circuit,  $C_{\text{F}}$  is the capacitance of the charge integrator circuit, and  $\Delta d_{\text{avg}}$  is the average displacement of the electrode. In Ref. 1  $V_{\text{out}}$  is maximized independently of the fabrication process and the buffer circuit. This means the layer thicknesses, material property ( $d_0$ ,  $h_{1\text{MD}}$ ,  $\epsilon_r$ ) and the circuit parameters ( $C_{\text{F}}$ ,  $A_{\text{BF}}$ ) are unchanged.  $\Delta d_{\text{avg}}$  characterizes a specific electrode-mass structure and is the only parameter in the expression that is changed through mask design. In comparison to the standard design, the piston-shaped electrode (see Figure 7, Top-Right) results in reduced electrode curvature and, consequently, increased  $\Delta d_{\text{avg}}$ . The improvement is reflected in the CMUT displacement uniformity factor,  $F$ , given by

$$F = \Delta d_{\text{avg}} / \Delta d_{\text{max}}$$

which can be calculated using the Average and Minimum coupling operators.

The model geometry is fully parameterized to allow for easy changes in the device structure to target a specific resonant frequency. The model solves a multiphysics problem involving electromechanical force and calculates the frequency response of the device using a **Frequency Domain, Prestressed** study. The device is connected to an external circuit using the **Electrical Circuit** interface for calculating the output current. The model uses built-in operators to compute average and minimum displacements over the electrode surface to calculate the displacement uniformity factor.

### *Results and Discussion*

Figure 3 shows the frequency response over the range 1.5–2.5 MHz to measure electrode displacement and output current.

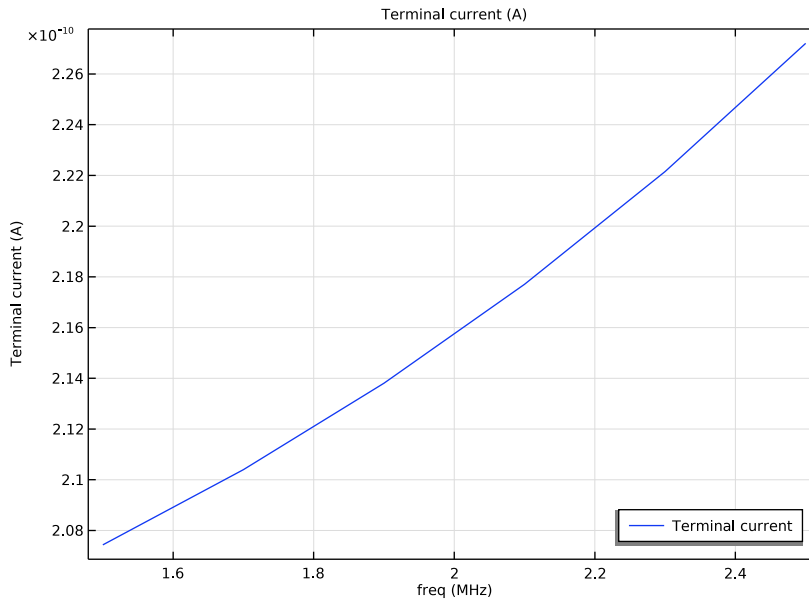

Figure 3: Current versus frequency.

Figure 4 shows profile of the top-electrode cross section as a function of the frequency.

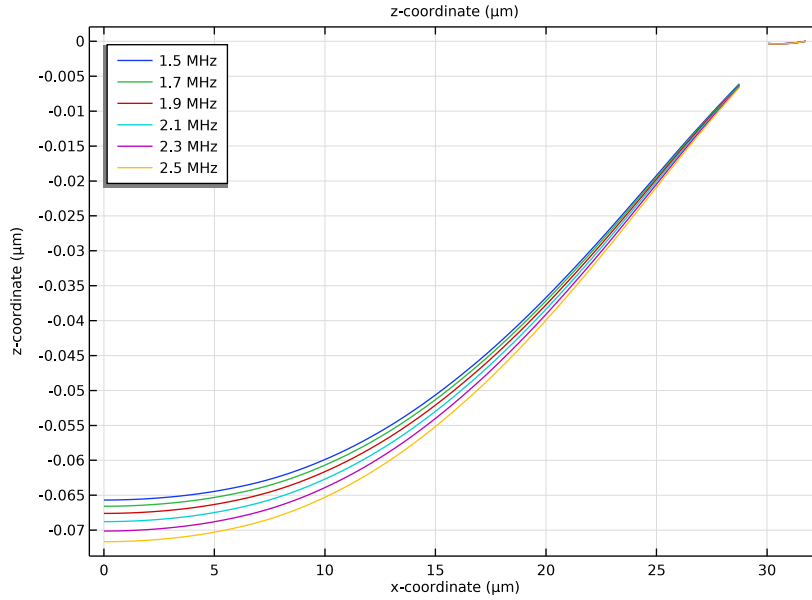
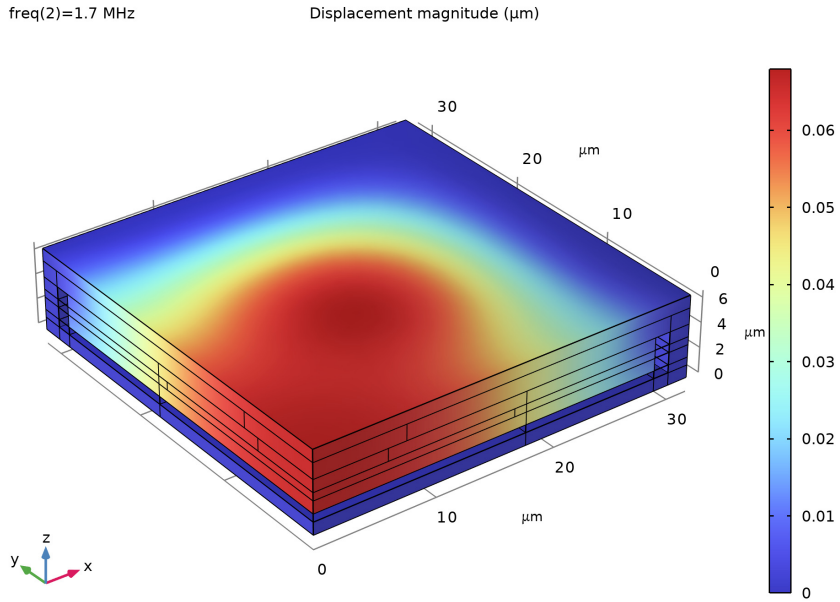

Figure 4: Profile of the top electrode as a function of frequency. Maximum displacement is at the center of the device and is about 65 nm at 1.7 MHz.

Figure 5 shows the solid displacement of the structure with a harmonic perturbation at 1.7 MHz. The maximum displacement is at the center of the device and is about 65 nm.



*Figure 5: The solid displacement of the structure with a harmonic perturbation at 1.7 MHz. Maximum displacement is at the center of the device and is about 65 nm.*

The subsequent **Eigenfrequency** study shows an eigenmode at 7.5 MHz which closely matches the reported value of 7.52 MHz (Ref. 1). Figure 6 shows solid displacement for the eigenmode.

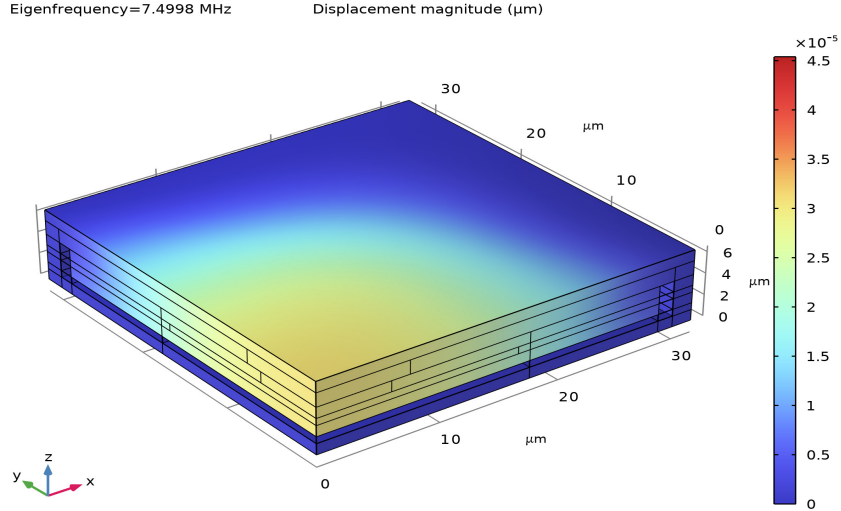

*Figure 6: Solid displacement for eigenmode at 7.5 MHz.*

Figure 7 shows the comparison between the standard and piston-shaped CMUT. As expected, the displacement is maximal at the center of the device and for the conventional device the pattern is more circular and therefore the displacement is highly nonuniform. In the piston-shaped device the corners of the suspended mass are not connected to the membrane to allow more uniform displacement along the diagonals of the device. According Ref. 1, the  $F$  value for a conventional CMUT is 0.6 so the piston-shaped design improves the output of the device by about 40%.

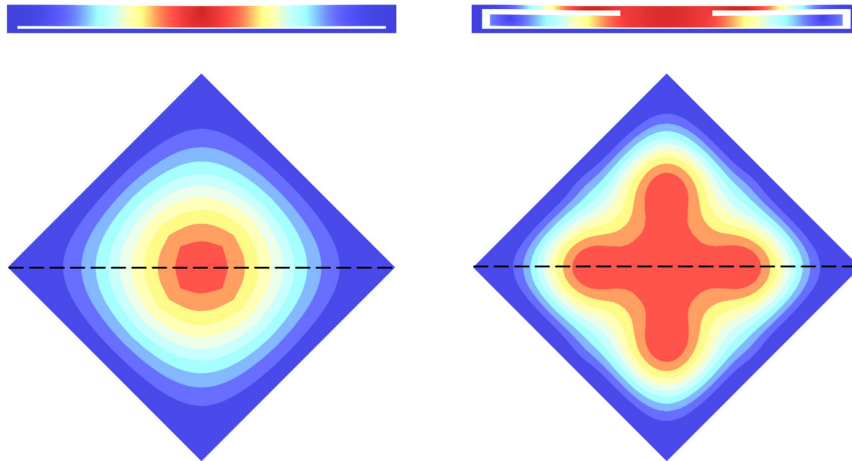

*Figure 7: CMUT cross sections along the diagonals (dashed line) for the standard design (Top-Left) and the piston-shaped design (Top-Right). Displacement across CMUT for the standard design (Bottom-Left) and the piston-shaped design (Bottom-Right). The piston-shaped suspended mass increases displacement uniformity.*

### *Reference*

---

I. C. Chou, P. Chen, H. Wu, T. Hsu, and M. Li, “Piston-Shaped CMOS-MEMS CMUT Front-End Featuring Force-Displacement Transduction Enhancement,” *Proceedings of the 21st International Conference on Solid-State Sensors, Actuators and Microsystems (Transducers)*, pp. 26–29, 2021.

---

**Application Library path:** MEMS\_Module/Sensors/  
capacitive\_micromachined\_ultrasonic\_transducer

---

### *Modeling Instructions*



Start by creating a new 3D model with **Electromechanics** and **Electrical Circuit** interfaces.

From the **File** menu, choose **New**.

## NEW

In the **New** window, click  **Model Wizard**.

## MODEL WIZARD

- 1 In the **Model Wizard** window, click .
- 2 In the **Select Physics** tree, select **AC/DC** > **Electromagnetics and Mechanics** > **Electromechanics** > **Electromechanics, Solid**.
- 3 Click **Add**.
- 4 In the **Select Physics** tree, select **AC/DC** > **Electrical Circuit (cir)**.
- 5 Click **Add**.
- 6 Click  **Study**.
- 7 In the **Select Study** tree, select **Preset Studies for Selected Physics Interfaces** > **Solid Mechanics** > **Frequency Domain, Prestressed**.
- 8 Click  **Done**.

Define and enter the values for the following parameters.

## GLOBAL DEFINITIONS

### Parameters 1

- 1 In the **Model Builder** window, under **Global Definitions** click **Parameters 1**.
- 2 In the **Settings** window for **Parameters**, locate the **Parameters** section.
- 3 In the table, enter the following settings:

Name	Expression	Value	Description
l	63.5[um]	6.35E-5 m	Length of device
l_et	33[um]	3.3E-5 m	Length of top electrode
l_eb	35[um]	3.5E-5 m	Length of bottom electrode
t_ox	1[um]	1E-6 m	Thickness of oxide
t_m2	0.64[um]	6.4E-7 m	Thickness of sacrificial metal, M2
t_m3	0.64[um]	6.4E-7 m	Thickness of top electrode, M3
t_m4	1.28[um]	1.28E-6 m	Thickness of support metal, M4

Name	Expression	Value	Description
t_w	3.4[um]	3.4E-6 m	Thickness of wall
w_ox	11.25[um]	1.125E-5 m	Width of oxide around top electrode
l_v43	12[um]	1.2E-5 m	Length of via 4-3
l_m4	15[um]	1.5E-5 m	Length of support metal
w_b	3.6[um]	3.6E-6 m	Width of support beam
t_np	1[um]	1E-6 m	Thickness of nitride passivation layer
p_max	1[MPa]	1E6 Pa	Maximum pressure
R_load	1[Gohm]	1E9 Ω	Load resistance
V_a	5[V]	5 V	Applied voltage

Use microns as the geometry unit.

## GEOMETRY I

- 1 In the **Model Builder** window, under **Component 1 (comp1)** click **Geometry 1**.
- 2 In the **Settings** window for **Geometry**, locate the **Units** section.
- 3 From the **Length unit** list, choose **μm**.

### Work Plane 1 (wp1)

In the **Geometry** toolbar, click  **Work Plane**.

### Work Plane 1 (wp1) > Plane Geometry

In the **Model Builder** window, click **Plane Geometry**.

### Device

- 1 In the **Work Plane** toolbar, click  **Square**.
- 2 In the **Settings** window for **Square**, type Device in the **Label** text field.
- 3 Locate the **Size** section. In the **Side length** text field, type 1/2.

### Piston

- 1 In the **Work Plane** toolbar, click  **Square**.
- 2 In the **Settings** window for **Square**, type Piston in the **Label** text field.
- 3 Locate the **Size** section. In the **Side length** text field, type  $l_{eb}/2 + w_{ox}$ .

### Inside Wall

- 1 In the **Work Plane** toolbar, click  **Square**.
- 2 In the **Settings** window for **Square**, type Inside Wall in the **Label** text field.

3 Locate the **Size** section. In the **Side length** text field, type  $1/2-t_w/2$ .

#### *Bottom Electrode*

- 1 In the **Work Plane** toolbar, click  **Square**.
- 2 In the **Settings** window for **Square**, type Bottom Electrode in the **Label** text field.
- 3 Locate the **Size** section. In the **Side length** text field, type  $1_{eb}/2$ .

#### *Oxide 1*

- 1 In the **Model Builder** window, right-click **Geometry 1** and choose **Extrude**.
- 2 In the **Settings** window for **Extrude**, type Oxide 1 in the **Label** text field.
- 3 Locate the **Distances** section. In the table, enter the following settings:

Distances ( $\mu\text{m}$ )
$t_{ox}$

#### *Metal 2*

- 1 In the **Geometry** toolbar, click  **Extrude**.
- 2 In the **Settings** window for **Extrude**, type Metal 2 in the **Label** text field.
- 3 Locate the **General** section. From the **Extrude from** list, choose **Faces**.
- 4 On the object **ext1**, select Boundaries 4, 8, 12, and 16 only.
- 5 From the **Input object handling** list, choose **Keep**.
- 6 Locate the **Distances** section. In the table, enter the following settings:

Distances ( $\mu\text{m}$ )
$t_{m2}$

#### *Oxide 2*

- 1 In the **Geometry** toolbar, click  **Extrude**.
- 2 In the **Settings** window for **Extrude**, type Oxide 2 in the **Label** text field.
- 3 Locate the **General** section. From the **Extrude from** list, choose **Faces**.
- 4 On the object **ext2**, select Boundaries 4, 8, 12, and 16 only.
- 5 From the **Input object handling** list, choose **Keep**.
- 6 Locate the **Distances** section. In the table, enter the following settings:

Distances ( $\mu\text{m}$ )
$t_{ox}$

### *Metal 3*

- 1 In the **Geometry** toolbar, click  **Extrude**.
- 2 In the **Settings** window for **Extrude**, type *Metal 3* in the **Label** text field.
- 3 Locate the **General** section. From the **Extrude from** list, choose **Faces**.
- 4 On the object **ext3**, select Boundaries 4, 8, 12, and 16 only.
- 5 From the **Input object handling** list, choose **Keep**.
- 6 Locate the **Distances** section. In the table, enter the following settings:

---

<b>Distances (μm)</b>
t_m3

---

### *Oxide 3*

- 1 In the **Geometry** toolbar, click  **Extrude**.
- 2 In the **Settings** window for **Extrude**, type *Oxide 3* in the **Label** text field.
- 3 Locate the **General** section. From the **Extrude from** list, choose **Faces**.
- 4 On the object **ext4**, select Boundaries 4, 8, 12, and 16 only.
- 5 From the **Input object handling** list, choose **Keep**.
- 6 Locate the **Distances** section. In the table, enter the following settings:

---

<b>Distances (μm)</b>
t_ox

---

### *Work Plane 2 (wp2)*

- 1 In the **Geometry** toolbar, click  **Work Plane**.
- 2 In the **Settings** window for **Work Plane**, locate the **Plane Definition** section.
- 3 In the **z-coordinate** text field, type  $t_{ox}+t_{m2}+t_{ox}+t_{m3}+t_{ox}$ .

### *Work Plane 2 (wp2) > Plane Geometry*

In the **Model Builder** window, click **Plane Geometry**.

### *Support, Center*

- 1 In the **Work Plane** toolbar, click  **Square**.
- 2 In the **Settings** window for **Square**, type *Support, Center* in the **Label** text field.
- 3 Locate the **Size** section. In the **Side length** text field, type  $1_{m4}/2$ .

### *Support, x*

- 1 In the **Work Plane** toolbar, click  **Rectangle**.

- 2 In the **Settings** window for **Rectangle**, type Support, x in the **Label** text field.
- 3 Locate the **Size and Shape** section. In the **Width** text field, type  $1/2 \cdot l_{m4}/2$ .
- 4 In the **Height** text field, type  $w_b/2$ .
- 5 Locate the **Position** section. In the **xw** text field, type  $l_{m4}/2$ .

*Support, y*

- 1 In the **Work Plane** toolbar, click  **Rectangle**.
- 2 In the **Settings** window for **Rectangle**, type Support, y in the **Label** text field.
- 3 Locate the **Size and Shape** section. In the **Width** text field, type  $w_b/2$ .
- 4 In the **Height** text field, type  $1/2 \cdot l_{m4}/2$ .
- 5 Locate the **Position** section. In the **yw** text field, type  $l_{m4}/2$ .

*Device, Upper*

- 1 In the **Work Plane** toolbar, click  **Square**.
- 2 In the **Settings** window for **Square**, type Device, Upper in the **Label** text field.
- 3 Locate the **Size** section. In the **Side length** text field, type  $l/2$ .

*Inside Wall, Upper*

- 1 In the **Work Plane** toolbar, click  **Square**.
- 2 In the **Settings** window for **Square**, type Inside Wall, Upper in the **Label** text field.
- 3 Locate the **Size** section. In the **Side length** text field, type  $1/2 \cdot t_w/2$ .

*Metal 4*

- 1 In the **Model Builder** window, under **Component 1 (comp1) > Geometry 1** right-click **Work Plane 2 (wp2)** and choose **Extrude**.
- 2 In the **Settings** window for **Extrude**, type Metal 4 in the **Label** text field.
- 3 Locate the **General** section. From the **Input object handling** list, choose **Keep**.
- 4 Locate the **Distances** section. In the table, enter the following settings:

<b>Distances (<math>\mu\text{m}</math>)</b>
$t_{m4}$

*Nitride*

- 1 In the **Geometry** toolbar, click  **Block**.
- 2 In the **Settings** window for **Block**, type Nitride in the **Label** text field.
- 3 Locate the **Size and Shape** section. In the **Width** text field, type  $l/2$ .
- 4 In the **Depth** text field, type  $l/2$ .

- 5 In the **Height** text field, type  $t_{np}$ .
- 6 Locate the **Position** section. In the **z** text field, type  $t_{ox}+t_{m2}+t_{ox}+t_{m3}+t_{ox}+ t_{m4}$ .
- 7 Locate the **Selections of Resulting Entities** section. Select the **Resulting objects selection** checkbox.
- 8 Find the **Cumulative selection** subsection. Click **New**.
- 9 In the **New Cumulative Selection** dialog, type Passivation in the **Name** text field.
- 10 Click **OK**.
- 11 In the **Settings** window for **Block**, locate the **Selections of Resulting Entities** section.
- 12 From the **Color** list, choose **None** or — if you are running the cross-platform desktop — **Custom**. On the cross-platform desktop, click the **Color** button.
- 13 Click **Define custom colors**.
- 14 Set the RGB values to 255, 255, and 155, respectively.
- 15 Click **Add to custom colors**.
- 16 Click **Show color palette only** or **OK** on the cross-platform desktop.

*Via*

- 1 In the **Geometry** toolbar, click  **Block**.
- 2 In the **Settings** window for **Block**, type *Via* in the **Label** text field.
- 3 Locate the **Size and Shape** section. In the **Width** text field, type  $1_{v43}/2$ .
- 4 In the **Depth** text field, type  $1_{v43}/2$ .
- 5 In the **Height** text field, type  $t_{ox}$ .
- 6 Locate the **Position** section. In the **z** text field, type  $t_{ox}+t_{m2}+t_{ox}+t_{m3}$ .

*Top Electrode*

- 1 In the **Geometry** toolbar, click  **Block**.
- 2 In the **Settings** window for **Block**, type *Top Electrode* in the **Label** text field.
- 3 Locate the **Size and Shape** section. In the **Width** text field, type  $1_{et}/2$ .
- 4 In the **Depth** text field, type  $1_{et}/2$ .
- 5 In the **Height** text field, type  $t_{m3}$ .
- 6 Locate the **Position** section. In the **z** text field, type  $t_{ox}+t_{m2}+t_{ox}$ .



*Form Union (fin)*

- 1 In the **Model Builder** window, click **Form Union (fin)**.
- 2 In the **Settings** window for **Form Union/Assembly**, click  **Build Selected**.



Define the following selections for the Gap, Oxide, and Electrode regions.

## DEFINITIONS



### *Gap*

- 1 In the **Definitions** toolbar, click  **Explicit**.
- 2 In the **Settings** window for **Explicit**, type Gap in the **Label** text field.
- 3 Locate the **Input Entities** section. Click  **Paste Selection**.
- 4 In the **Paste Selection** dialog, type 2 12 17 18 19 20 27 in the **Selection** text field.
- 5 Click **OK**.

### *Oxide*

- 1 In the **Definitions** toolbar, click  **Explicit**.
- 2 In the **Settings** window for **Explicit**, type Oxide in the **Label** text field.
- 3 Locate the **Input Entities** section. Click  **Paste Selection**.
- 4 In the **Paste Selection** dialog, type 1 3 8 10 11 13 14 15 16 21 22 23 24 25 28 in the **Selection** text field.
- 5 Click **OK**.

### *Electrode*



- 1 In the **Definitions** toolbar, click  **Explicit**.
- 2 In the **Settings** window for **Explicit**, type Electrode in the **Label** text field.
- 3 Locate the **Input Entities** section. Click  **Paste Selection**.
- 4 In the **Paste Selection** dialog, type 4 5 6 9 26 29 30 in the **Selection** text field.
- 5 Click **OK**.

### *Edge, Center*



- 1 In the **Definitions** toolbar, click  **Box**.
- 2 In the **Settings** window for **Box**, type Edge, Center in the **Label** text field.
- 3 Locate the **Geometric Entity Level** section. From the **Level** list, choose **Edge**.
- 4 Locate the **Box Limits** section. In the **x maximum** text field, type 0.
- 5 In the **y maximum** text field, type 0.
- 6 Locate the **Output Entities** section. From the **Include entity if** list, choose **Entity inside box**.

Define the Average and Minimum operators needed for evaluation.

### *Average 1 (aveop1)*

- 1 In the **Definitions** toolbar, click  **Nonlocal Couplings** and choose **Average**.
- 2 In the **Settings** window for **Average**, locate the **Source Selection** section.
- 3 From the **Geometric entity level** list, choose **Boundary**.
- 4 Click  **Paste Selection**.
- 5 In the **Paste Selection** dialog, type 12 in the **Selection** text field.
- 6 Click **OK**.

### *Minimum 1 (minop1)*

- 1 In the **Definitions** toolbar, click  **Nonlocal Couplings** and choose **Minimum**.
- 2 In the **Settings** window for **Minimum**, locate the **Source Selection** section.
- 3 From the **Geometric entity level** list, choose **Boundary**.
- 4 Click  **Paste Selection**.
- 5 In the **Paste Selection** dialog, type 12 in the **Selection** text field.
- 6 Click **OK**.

Add materials to the model.

## **ADD MATERIAL**

- 1 In the **Materials** toolbar, click  **Add Material** to open the **Add Material** window.
- 2 Go to the **Add Material** window.
- 3 In the tree, select **MEMS > Metals > Al - Aluminum**.
- 4 Click the **Add to Component** button in the window toolbar.

## **MATERIALS**

### *Al - Aluminum (mat1)*

- 1 In the **Settings** window for **Material**, locate the **Geometric Entity Selection** section.
- 2 From the **Selection** list, choose **Electrode**.
- 3 Locate the **Material Contents** section. In the table, enter the following settings:

<b>Property</b>	<b>Variable</b>	<b>Value</b>	<b>Unit</b>	<b>Property group</b>
Relative permittivity	epsilon <sub>r_1iso</sub> ; epsilon <sub>r_1ii</sub> = epsilon <sub>r_1iso</sub> , epsilon <sub>r_1ij</sub> = 0	1		Basic

### **ADD MATERIAL**

- 1 Go to the **Add Material** window.
- 2 In the tree, select **MEMS > Insulators > SiO2 - Silicon oxide**.
- 3 Click the **Add to Component** button in the window toolbar.

### **MATERIALS**

*SiO2 - Silicon oxide (mat2)*

- 1 In the **Settings** window for **Material**, locate the **Geometric Entity Selection** section.
- 2 From the **Selection** list, choose **Oxide**.

### **ADD MATERIAL**

- 1 Go to the **Add Material** window.
- 2 In the tree, select **MEMS > Insulators > Si3N4 - Silicon nitride**.
- 3 Click the **Add to Component** button in the window toolbar.

### **MATERIALS**

*Si3N4 - Silicon nitride (mat3)*

- 1 In the **Settings** window for **Material**, locate the **Geometric Entity Selection** section.
- 2 From the **Selection** list, choose **Passivation**.

3 In the **Model Builder** window, under **Component 1 (comp1)** click **Materials**.

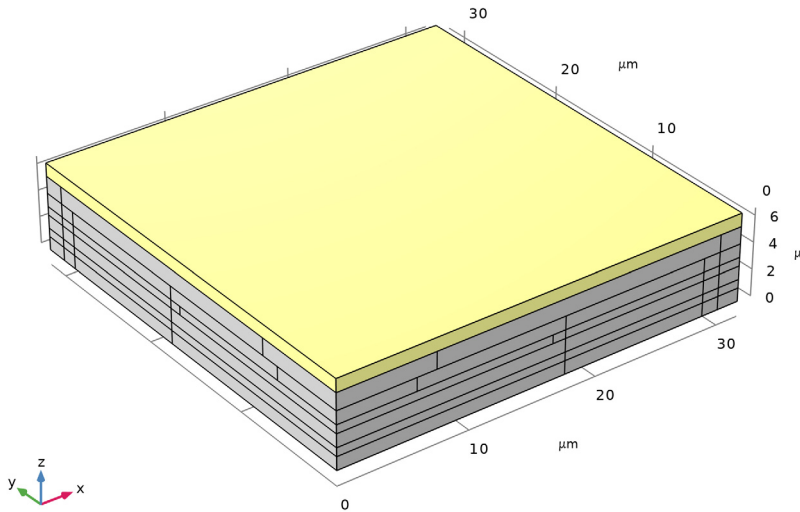

## MOVING MESH

### *Deforming Domain 1*

- 1 In the **Model Builder** window, under **Component 1 (comp1)** > **Moving Mesh** click **Deforming Domain 1**.
- 2 In the **Settings** window for **Deforming Domain**, locate the **Domain Selection** section.
- 3 From the **Selection** list, choose **Gap**.

### *Symmetry/Roller 1*

- 1 In the **Model Builder** window, click **Symmetry/Roller 1**.
- 2 Select Boundaries 4, 5, 38, 54, 57, 60, 63, 117, 128, 130, 132, and 134 only.

Because this model uses the **Electrical Circuit** interface, for Discretization select the Finite element (quadratic shape function) formulation.

## ELECTROSTATICS (ES)

- 1 In the **Model Builder** window, under **Component 1 (comp1)** click **Electrostatics (es)**.
- 2 In the **Settings** window for **Electrostatics**, click to expand the **Discretization** section.
- 3 From the **Formulation** list, choose **Finite element (quadratic shape function)**.

Set up **Electrostatics** boundary conditions.



#### *Charge Conservation in Solids I*

- 1 In the **Model Builder** window, under **Component 1 (comp1) > Electrostatics (es)** click **Charge Conservation in Solids I**.
- 2 In the **Settings** window for **Charge Conservation in Solids**, locate the **Domain Selection** section.
- 3 Click  **Clear Selection**.
- 4 Select Domains 1, 3, 7, 8, 10, 11, 13–16, 21–25, and 28 only.



#### *Domain Terminal I*

- 1 In the **Physics** toolbar, click  **Domains** and choose **Domain Terminal**.
- 2 In the **Settings** window for **Domain Terminal**, locate the **Domain Selection** section.
- 3 From the **Selection** list, choose **Electrode**.
- 4 Locate the **Terminal** section. From the **Terminal type** list, choose **Circuit**.

#### *Ground I*

- 1 In the **Physics** toolbar, click  **Boundaries** and choose **Ground**.
- 2 In the **Settings** window for **Ground**, locate the **Boundary Selection** section.
- 3 Click  **Paste Selection**.
- 4 In the **Paste Selection** dialog, type 3 in the **Selection** text field.
- 5 Click **OK**.



#### *Symmetry Plane I*

- 1 In the **Physics** toolbar, click  **Boundaries** and choose **Symmetry Plane**.
- 2 In the **Settings** window for **Symmetry Plane**, locate the **Boundary Selection** section.
- 3 Click  **Paste Selection**.
- 4 In the **Paste Selection** dialog, type 2 5 8 11 14 17 20 105 107 113 115 117 119 121 123 126 128 130 132 134 137 139 141 143 145 147 in the **Selection** text field.

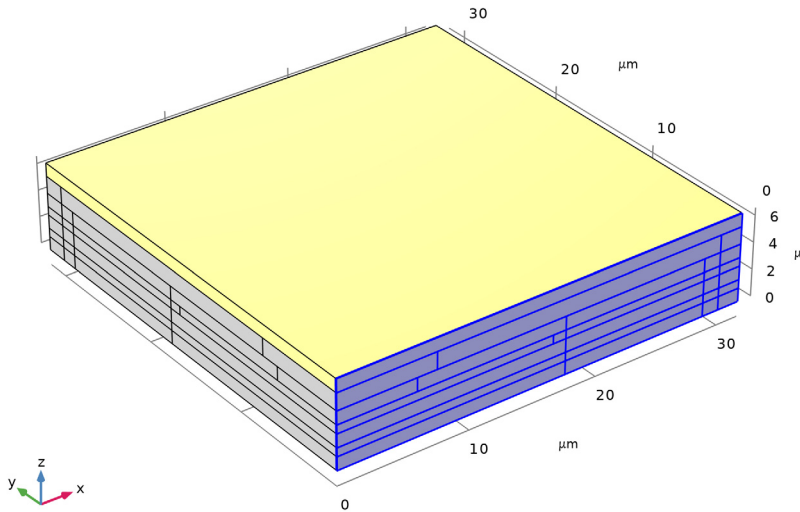
5 Click **OK**.



#### *Symmetry Plane 2*

- 1 In the **Physics** toolbar, click  **Boundaries** and choose **Symmetry Plane**.
- 2 In the **Settings** window for **Symmetry Plane**, locate the **Boundary Selection** section.
- 3 Click  **Paste Selection**.
- 4 In the **Paste Selection** dialog, type 1 4 7 10 13 16 19 23 27 31 35 38 41 44 47 51 54 57 60 63 67 70 73 76 79 82 in the **Selection** text field.
- 5 Click **OK**.

Set up **Solid Mechanics** boundary conditions.

#### **SOLID MECHANICS (SOLID)**

In the **Model Builder** window, under **Component 1 (comp1)** click **Solid Mechanics (solid)**.

#### *Symmetry 1*

In the **Physics** toolbar, click  **Boundaries** and choose **Symmetry**.

## ELECTROSTATICS (ES)

### *Symmetry Plane 1*

- 1 In the **Model Builder** window, under **Component 1 (comp1) > Electrostatics (es)** click **Symmetry Plane 1**.
- 2 In the **Settings** window for **Symmetry Plane**, locate the **Boundary Selection** section.
- 3 In the list, choose **2, 5, 8, 11, 14, 17, 20, 105, 107, 113, 115, 117, 119, 121, 123, 126, 128, 130, 132, 134, 137, 139, 141, 143, 145, and 147**.
- 4 Click  **Copy Selection**.

## SOLID MECHANICS (SOLID)

### *Symmetry 1*

- 1 In the **Model Builder** window, under **Component 1 (comp1) > Solid Mechanics (solid)** click **Symmetry 1**.
- 2 In the **Settings** window for **Symmetry**, locate the **Boundary Selection** section.
- 3 Click  **Paste Selection**.
- 4 In the **Paste Selection** dialog, type **2 5 8 11 14 17 20 105 107 113 115 117 119 121 123 126 128 130 132 134 137 139 141 143 145 147** in the **Selection** text field.
- 5 Click **OK**.

### *Symmetry 2*

In the **Physics** toolbar, click  **Boundaries** and choose **Symmetry**.

## ELECTROSTATICS (ES)

### *Symmetry Plane 2*

- 1 In the **Model Builder** window, under **Component 1 (comp1) > Electrostatics (es)** click **Symmetry Plane 2**.
- 2 In the **Settings** window for **Symmetry Plane**, locate the **Boundary Selection** section.
- 3 In the list, choose **1, 4, 7, 10, 13, 16, 19, 23, 27, 31, 35, 38, 41, 44, 47, 51, 54, 57, 60, 63, 67, 70, 73, 76, 79, and 82**.
- 4 Click  **Copy Selection**.



## SOLID MECHANICS (SOLID)

### *Symmetry 2*

- 1 In the **Model Builder** window, under **Component 1 (comp1) > Solid Mechanics (solid)** click **Symmetry 2**.



- 2 In the **Settings** window for **Symmetry**, locate the **Boundary Selection** section.
- 3 Click  **Paste Selection**.
- 4 In the **Paste Selection** dialog, type 1 4 7 10 13 16 19 23 27 31 35 38 41 44 47 51 54 57 60 63 67 70 73 76 79 82 in the **Selection** text field.
- 5 Click **OK**.

#### *Fixed Constraint I*

- 1 In the **Physics** toolbar, click  **Boundaries** and choose **Fixed Constraint**.
- 2 In the **Settings** window for **Fixed Constraint**, locate the **Boundary Selection** section.
- 3 Click  **Paste Selection**.
- 4 In the **Paste Selection** dialog, type 3 37 53 69 86 87 88 89 90 91 92 103 152 153 154 155 156 157 158 159 in the **Selection** text field.
- 5 Click **OK**.

Specify a **Boundary Load** feature with **Harmonic Perturbation** to model an excitation by a pressure wave.

#### *Boundary Load I*

- 1 In the **Physics** toolbar, click  **Boundaries** and choose **Boundary Load**.
- 2 In the **Settings** window for **Boundary Load**, locate the **Boundary Selection** section.
- 3 Click  **Paste Selection**.
- 4 In the **Paste Selection** dialog, type 22 in the **Selection** text field.
- 5 Click **OK**.
- 6 In the **Settings** window for **Boundary Load**, locate the **Force** section.
- 7 From the **Load type** list, choose **Pressure**.
- 8 In the  $p$  text field, type  $p_{\max}$ .
- 9 Right-click **Boundary Load I** and choose **Harmonic Perturbation**.

Set up **Electrical Circuit** parameters and specify how the device terminals are connected to the external circuit.

### **ELECTRICAL CIRCUIT (CIR)**

#### *External I vs. U I (IvsUI)*

- 1 In the **Electrical Circuit** toolbar, click  **External I vs. U**.
- 2 In the **Settings** window for **External I vs. U**, locate the **Node Connections** section.

3 In the table, enter the following settings:

Label	Node names
n	0

4 Locate the **External Device** section. From the  $V$  list, choose **Terminal voltage (es/term1)**.

#### *Resistor 1 (R1)*

1 In the **Electrical Circuit** toolbar, click  **Resistor**.

2 In the **Settings** window for **Resistor**, locate the **Node Connections** section.

3 In the table, enter the following settings:

Label	Node names
p	1
n	2

4 Locate the **Device Parameters** section. In the  $R$  text field, type  $R\_load$ .

#### *Voltage Source 1 (V1)*

1 In the **Electrical Circuit** toolbar, click  **Voltage Source**.

2 In the **Settings** window for **Voltage Source**, locate the **Node Connections** section.

3 In the table, enter the following settings:

Label	Node names
p	2
n	0

4 Locate the **Device Parameters** section. In the  $v_{src}$  text field, type  $V\_a$ .

#### **MESH 1**

1 In the **Model Builder** window, under **Component 1 (comp1)** click **Mesh 1**.

2 In the **Settings** window for **Mesh**, locate the **Physics-Controlled Mesh** section.

3 From the **Element size** list, choose **Extra coarse**.

Set up the steps for a **Frequency Domain, Prestressed** study.

#### **STUDY 1**

1 In the **Model Builder** window, click **Study 1**.

2 In the **Settings** window for **Study**, locate the **Study Settings** section.

3 Clear the **Generate default plots** checkbox.

*Step 2: Frequency-Domain Perturbation*

- 1 In the **Model Builder** window, under **Study 1** click **Step 2: Frequency-Domain Perturbation**.
- 2 In the **Settings** window for **Frequency-Domain Perturbation**, locate the **Study Settings** section.
- 3 From the **Frequency unit** list, choose **MHz**.
- 4 In the **Frequencies** text field, type range (1.5,0.2,2.5).
- 5 In the **Study** toolbar, click  **Compute**.

From the results of Study 1, plot the terminal current versus frequency.

## RESULTS

*Terminal Current vs. Frequency*

- 1 In the **Results** toolbar, click  **ID Plot Group**.
- 2 In the **Settings** window for **ID Plot Group**, type Terminal Current vs. Frequency in the **Label** text field.
- 3 Locate the **Legend** section. From the **Position** list, choose **Lower right**.

*Global I*

- 1 Right-click **Terminal Current vs. Frequency** and choose **Global**.
- 2 In the **Settings** window for **Global**, locate the **y-Axis Data** section.
- 3 In the table, enter the following settings:

Expression	Unit	Description
es.I0_1	A	Terminal current

4 In the **Terminal Current vs. Frequency** toolbar, click  **Plot**.

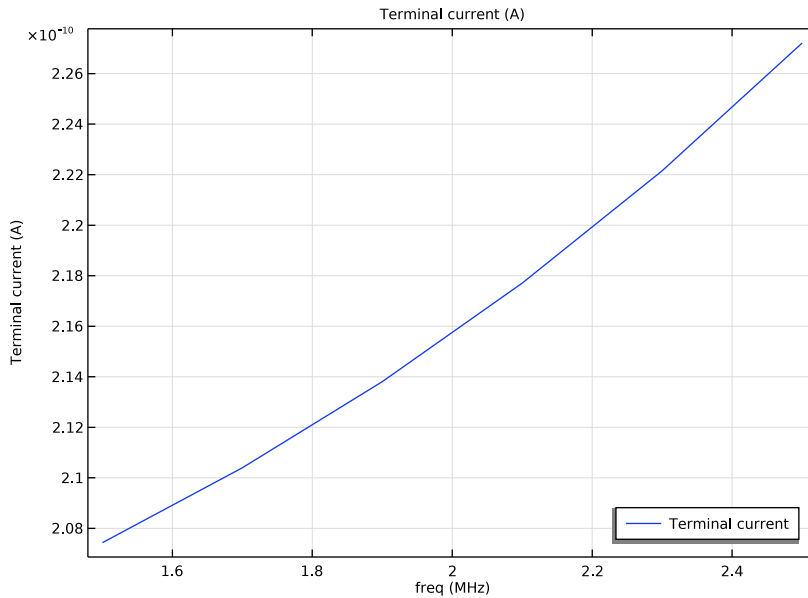

From the results of Study 1, plot the electrode profile.

#### *Electrode Profile*

- 1 In the **Results** toolbar, click  **ID Plot Group**.
- 2 In the **Settings** window for **ID Plot Group**, type **Electrode Profile** in the **Label** text field.
- 3 Locate the **Legend** section. From the **Position** list, choose **Upper left**.

#### *Line Graph 1*

- 1 Right-click **Electrode Profile** and choose **Line Graph**.
- 2 Select Edges 12, 144, 159, and 207 only.
- 3 In the **Settings** window for **Line Graph**, locate the **y-Axis Data** section.
- 4 In the **Expression** text field, type **z**.
- 5 Select the **Description** checkbox.
- 6 Locate the **x-Axis Data** section. From the **Parameter** list, choose **Expression**.
- 7 In the **Expression** text field, type **x**.
- 8 Select the **Description** checkbox.

- 9 Locate the **y-Axis Data** section. Select the **Compute differential** checkbox.
- 10 Click to expand the **Legends** section. Select the **Show legends** checkbox.
- 11 In the **Electrode Profile** toolbar, click  **Plot**.

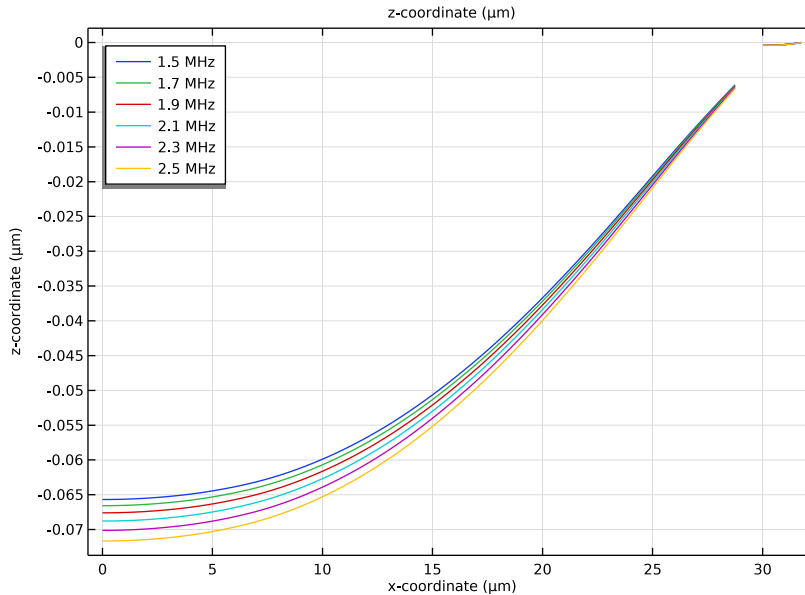

From the results of Study 1, plot the displacement magnitude.

#### *Displacement Magnitude*

- 1 In the **Results** toolbar, click  **3D Plot Group**.
- 2 In the **Settings** window for **3D Plot Group**, type **Displacement Magnitude** in the **Label** text field.
- 3 Locate the **Data** section. From the **Parameter value (freq (MHz))** list, choose **1.7**.

#### *Volume 1*

- 1 Right-click **Displacement Magnitude** and choose **Volume**.
- 2 In the **Settings** window for **Volume**, click **Replace Expression** in the upper-right corner of the **Expression** section. From the menu, choose **Component 1 (comp1) > Solid Mechanics > Displacement > solid.disp - Displacement magnitude - m**.
- 3 Locate the **Expression** section. Select the **Description** checkbox.
- 4 Locate the **Coloring and Style** section. From the **Color table** list, choose **RainbowLight**.

5 In the **Displacement Magnitude** toolbar, click  **Plot**.

freq(2)=1.7 MHz

Displacement magnitude ( $\mu\text{m}$ )

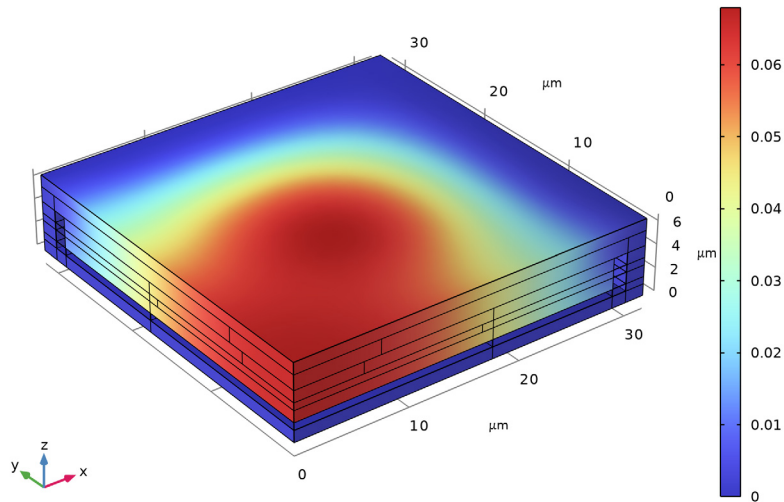

From the results of Study 1, evaluate the displacement uniformity factor.

*Displacement Uniformity Factor*

1 In the **Results** toolbar, click  **Evaluation Group**.

2 In the **Settings** window for **Evaluation Group**, type Displacement Uniformity Factor in the **Label** text field.

*Global Evaluation 1*

1 Right-click **Displacement Uniformity Factor** and choose **Global Evaluation**.

2 In the **Settings** window for **Global Evaluation**, locate the **Expressions** section.

3 In the table, enter the following settings:



Expression	Unit	Description
aveop1(w)/minop1(w)	1	

4 In the **Description** text field, type Displacement uniformity factor.

5 In the **Displacement Uniformity Factor** toolbar, click  **Evaluate**.

Set up an **Eigenfrequency** study to search for an eigenfrequency around 7.5 MHz.

## ADD STUDY

- 1 In the **Home** toolbar, click  **Add Study** to open the **Add Study** window.
- 2 Go to the **Add Study** window.
- 3 Find the **Studies** subsection. In the **Select Study** tree, select **Preset Studies for Selected Multiphysics > Eigenfrequency**.
- 4 Click the **Add Study** button in the window toolbar.
- 5 In the **Home** toolbar, click  **Add Study** to close the **Add Study** window.

## STUDY 2

### *Step 1: Eigenfrequency*

- 1 In the **Settings** window for **Eigenfrequency**, locate the **Study Settings** section.
- 2 Select the **Desired number of eigenfrequencies** checkbox. In the associated text field, type 1.
- 3 From the **Unit** list, choose **MHz**.
- 4 In the **Search for eigenfrequencies around shift** text field, type 7.5.
- 5 In the **Model Builder** window, click **Study 2**.
- 6 In the **Settings** window for **Study**, locate the **Study Settings** section.
- 7 Clear the **Generate default plots** checkbox.
- 8 In the **Study** toolbar, click  **Compute**.

From the results of Study 2, plot the eigenmode.

## RESULTS

### *Eigenmode*

- 1 In the **Results** toolbar, click  **3D Plot Group**.
- 2 In the **Settings** window for **3D Plot Group**, type **Eigenmode** in the **Label** text field.
- 3 Locate the **Data** section. From the **Dataset** list, choose **Study 2/Solution 3 (sol3)**.
- 4 From the **Eigenfrequency (MHz)** list, choose **7.4998**.

### *Volume 1*

- 1 Right-click **Eigenmode** and choose **Volume**.
- 2 In the **Settings** window for **Volume**, click **Replace Expression** in the upper-right corner of the **Expression** section. From the menu, choose **Component 1 (comp1) > Solid Mechanics > Displacement > solid.disp - Displacement magnitude - m**.
- 3 Locate the **Expression** section. Select the **Description** checkbox.

- 4 Locate the **Coloring and Style** section. From the **Color table** list, choose **RainbowLight**.
- 5 In the **Eigenmode** toolbar, click  **Plot**.

Eigenfrequency=7.4998 MHz

Displacement magnitude ( $\mu\text{m}$ )

