



Model created in COMSOL Multiphysics 6.4

Pull-In Voltage for a Biased Resonator – 3D

Introduction

Silicon micromechanical resonators have long been used for designing sensors and are now becoming increasingly important as oscillators in the consumer electronics market. In this sequence of models, a surface micromachined MEMS resonator, designed as part of a micromechanical filter, is analyzed in detail. The resonator is based on that developed in [Ref. 1](#).

This model performs a pull-in analysis of the structure, to predict the point at which the biased system becomes unstable. The analysis begins from the stationary analysis performed in the accompanying model [Stationary Analysis of a Biased Resonator — 3D](#); please review this model first.

Model Definition

The geometry, fabrication, and operation of the device are discussed for the [Stationary Analysis of a Biased Resonator — 3D](#) model.

This model computes the pull-in voltage for the resonator by solving an inverse problem. The z -coordinate of the resonator midpoint is computed using an integration operator (`intop1`). The inverse problem that COMSOL solves computes the DC voltage that must be applied to the beam in order to move the midpoint to a set z -coordinate, `zset`. This is achieved by adding a global equation for the DC voltage, `VdcSP`, applied to the resonator. The equation `intop1(z) - zset = 0` is solved to determine the value of `VdcSP`. This means that `VdcSP` is adjusted until the midpoint of the resonator has a z -coordinate given by the set value, `zset`. Essentially COMSOL is being asked to find the voltage that allows the beam to exist in equilibrium (stable or unstable) at a given displacement. Solving the problem in this way avoids complications with trying to solve a problem with no solution (which is what happens if the voltage is continuously ramped up eventually exceeding the pull-in voltage). The result of the analysis is a displacement versus voltage plot, with a maximum at the pull-in voltage. Note that for a linear spring, the pull-in displacement corresponds to $1/3$ of the gap distance. Although the inclusion of geometric nonlinearities in the solid mechanics solver means that the pull-in displacement changes slightly from this value, it is usually most efficient to search around this point for the pull-in voltage.

Results and Discussion

[Figure 1](#) shows the voltage-displacement curve for the resonator at equilibrium. The y -coordinate at which the pull in occurs corresponds to a displacements around $1/3$ of the gap size. The pull-in voltage is 59.2 V.

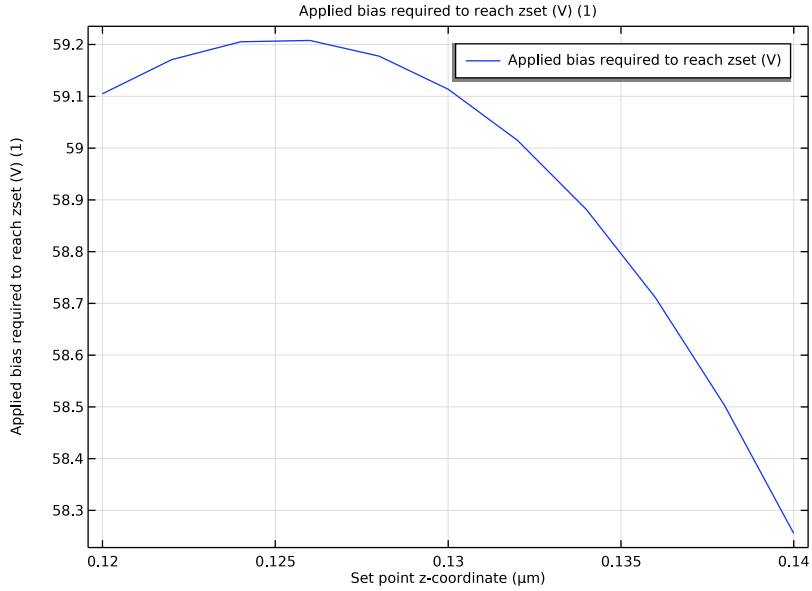

Figure 1: Voltage required to achieve a set displacement versus the target displacement. The pull-in voltage is the maximum of the plot: 59.2 V.

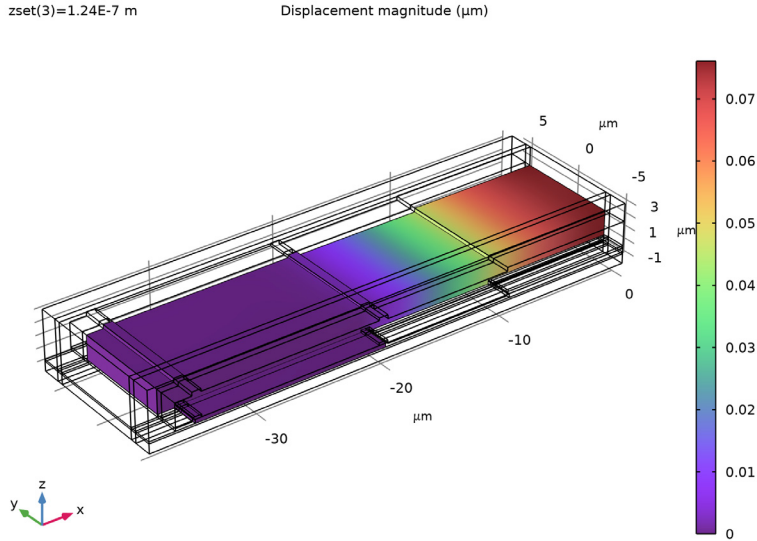

Figure 2: z-displacement of the resonator at pull-in. The displacement at pull-in is 75 nm. For a linear spring the displacement at pull in would be 66 nm.

Figure 2 shows the z -displacement of the resonator at the pull-in voltage. The maximum displacement at pull-in is 75 nm. This is comparable to the linear spring value of 66 nm.

Notes About the COMSOL Implementation

To compute the voltage required to generate the desired displacement of the beam, use a global equation. A common use of global equations is for computing the value of a dependent variable based on an ordinary differential equation in the dependent variable itself. However, it is also possible to couple a global equation with the other PDEs in the model as a powerful tool to solve certain kinds of inverse problems. This model uses a global equation to compute the potential applied to the drive electrode. The equation takes the form

$$z_0 = z_{\text{set}}$$

where z_0 is the z -coordinate of the midpoint of the beam's underside and z_{set} is the desired z -coordinate. COMSOL Multiphysics computes the voltage to satisfy the constraint implied by the above equation. Note that the large difference in scale between the set-

point displacement (10^{-7} m) and the applied voltages (10^2 V) means that care must be taken with the dependent variable scaling in the solver settings.

Reference

1. F.D. Bannon III, J.R. Clark and C.T.-C. Nguyen, “High-Q HF Microelectromechanical Filters,” *IEEE Journal of Solid State Circuits*, vol. 35, no. 4, pp. 512–526, 2000.

Application Library path: MEMS_Module/Actuators/
biased_resonator_3d_pull_in

Modeling Instructions

Open the existing stationary study (filename: biased_resonator_3d_basic.mph).

APPLICATION LIBRARIES

- 1 From the **File** menu, choose **Application Libraries**.
- 2 In the **Application Libraries** window, select **MEMS Module > Actuators > biased_resonator_3d_basic** in the tree.
- 3 Click  **Open**.
Add a parameter to set the z -coordinate of the midpoint of the resonator.

GLOBAL DEFINITIONS

Parameters 1

- 1 In the **Model Builder** window, under **Global Definitions** click **Parameters 1**.
- 2 In the **Settings** window for **Parameters**, locate the **Parameters** section.
- 3 In the table, enter the following settings:

Name	Expression	Value	Description
zset	100[nm]	1E-7 m	Set point z -coordinate

Add a nonlocal integration coupling to compute the actual displacement.

DEFINITIONS

Integration 1 (intop1)

- 1 In the **Model Builder** window, expand the **Component 1 (comp1)** node.
- 2 Right-click **Component 1 (comp1)** > **Definitions** and choose **Nonlocal Couplings** > **Integration**.
- 3 In the **Settings** window for **Integration**, locate the **Source Selection** section.
- 4 From the **Geometric entity level** list, choose **Point**.
- 5 Select Point 253 only.
To ensure convergence when using a global equation, change the geometry shape function to Linear Lagrange.

COMPONENT 1 (COMPI)

- 1 In the **Model Builder** window, click **Component 1 (comp1)**.
- 2 In the **Settings** window for **Component**, locate the **Curved Mesh Elements** section.
- 3 From the **Geometry shape function** list, choose **Linear Lagrange**.
Change the drive potential to the value V_{dcSP} - which will be solved for in a global equation.

ELECTROSTATICS (ES)

Terminal 2

- 1 In the **Model Builder** window, expand the **Electrostatics (es)** node, then click **Terminal 2**.
- 2 In the **Settings** window for **Domain Terminal**, locate the **Terminal** section.
- 3 In the V_0 text field, type V_{dcSP} .
Add a global equation to compute the voltage for a given displacement, V_{dcSP} .
- 4 Click the  **Show More Options** button in the **Model Builder** toolbar.
- 5 In the **Show More Options** dialog, in the tree, select the checkbox for the node **Physics** > **Equation Contributions**.
- 6 Click **OK**.



Global Equations 1 (ODE1)

- 1 In the **Physics** toolbar, click  **Global** and choose **Global Equations**.
- 2 In the **Settings** window for **Global Equations**, locate the **Global Equations** section.

3 In the table, enter the following settings:

Name	$f(u, ut, utt, t)$ (I)	Initial value (u_0) (I)	Initial value (ut_0) (I/s)	Description
VdcSP	intop1(z) - zset	0	0	Applied bias required to reach zset (V)



ADD STUDY

- 1 In the **Home** toolbar, click  **Add Study** to open the **Add Study** window.
- 2 Go to the **Add Study** window.
- 3 Find the **Studies** subsection. In the **Select Study** tree, select **General Studies > Stationary**.
- 4 Click the **Add Study** button in the window toolbar.
- 5 In the **Home** toolbar, click  **Add Study** to close the **Add Study** window.

STUDY 2



Step 1: Stationary

Make the following selections to use the previous study solution as the initial values of variables solved for.

- 1 In the **Settings** window for **Stationary**, click to expand the **Values of Dependent Variables** section.
- 2 Find the **Initial values of variables solved for** subsection. From the **Settings** list, choose **User controlled**.
- 3 From the **Method** list, choose **Solution**.
- 4 From the **Study** list, choose **Stationary, Stationary**.
Set up a parametric sweep over zset.
- 5 Click to expand the **Study Extensions** section. Select the **Auxiliary sweep** checkbox.
- 6 Click  **Add**.
- 7 From the list in the **Parameter name** column, choose **zset (Set point z-coordinate)**.
- 8 Click  **Range**.
- 9 In the **Range** dialog, type 120e-9 in the **Start** text field.
- 10 In the **Step** text field, type 2e-9.
- 11 In the **Stop** text field, type 140e-9.
- 12 Click **Replace**.

To ensure convergence when using a global equation, use the fully coupled solver.

Solution 2 (sol2)

- 1 In the **Study** toolbar, click  **Show Default Solver**.
- 2 In the **Model Builder** window, expand the **Solution 2 (sol2)** node.
- 3 In the **Model Builder** window, expand the **Study 2 > Solver Configurations > Solution 2 (sol2) > Stationary Solver 1** node.
- 4 Right-click **Study 2 > Solver Configurations > Solution 2 (sol2) > Stationary Solver 1** and choose **Fully Coupled**.
- 5 In the **Study** toolbar, click  **Compute**.
- 6 In the **Model Builder** window, right-click **Study 2** and choose **Rename**.
- 7 In the **Rename Study** dialog, type Pull In in the **New label** text field.
- 8 Click **OK**.
- 9 In the **Study** toolbar, click  **Compute**.

RESULTS

Displacement (solid) 1

Determine the pull-in voltage by plotting VdcSP versus zset.

ID Plot Group 9

- 1 In the **Results** toolbar, click  **ID Plot Group**.
- 2 In the **Settings** window for **ID Plot Group**, locate the **Data** section.
- 3 From the **Dataset** list, choose **Pull In/Solution 2 (sol2)**.

Global 1

- 1 Right-click **ID Plot Group 9** and choose **Global**.
- 2 In the **Settings** window for **Global**, click **Replace Expression** in the upper-right corner of the **y-Axis Data** section. From the menu, choose **Component 1 (comp1) > Electrostatics > VdcSP - Applied bias required to reach zset (V) - 1**.
- 3 Locate the **x-Axis Data** section. From the **Parameter** list, choose **Expression**.
- 4 In the **Expression** text field, type zset.

Pull-In Plot



- 1 In the **Model Builder** window, under **Results** click **ID Plot Group 9**.
- 2 In the **Settings** window for **ID Plot Group**, type Pull-In Plot in the **Label** text field.
- 3 In the **Pull-In Plot** toolbar, click  **Plot**.

- 4 Click the  **Zoom Extents** button in the **Graphics** toolbar.

Compare the resulting plot with [Figure 1](#). The pull in voltage is the maximum of the curve: 59.2 V at $z_{set} = 126$ nm.

Now look at the displacement at pull in. The default plot group can be used.

Displacement (solid) I

- 1 In the **Model Builder** window, click **Displacement (solid) I**.
- 2 In the **Settings** window for **3D Plot Group**, locate the **Data** section.
- 3 From the **Parameter value (zset (m))** list, choose **1.24E-7**.
- 4 In the **Displacement (solid) I** toolbar, click  **Plot**.
- 5 Click the  **Zoom Extents** button in the **Graphics** toolbar.

Compare the resulting plot with [Figure 2](#). The displacement at pull-in is 75 nm.