



Model created in COMSOL Multiphysics 6.4

Normal Modes of a Biased Resonator – 3D

Introduction

Silicon micromechanical resonators have long been used for designing sensors and are now becoming increasingly important as oscillators in the consumer electronics market. In this sequence of models, a surface micromachined MEMS resonator, designed as part of a micromechanical filter, is analyzed in detail. The resonator is based on that developed in [Ref. 1](#).

This model performs a modal analysis on the resonator, with and without an applied DC bias. The analysis begins from the stationary analysis performed in the accompanying model [Stationary Analysis of a Biased Resonator — 3D](#); please review this model first.

Model Definition

The geometry, fabrication, and operation of the device are discussed for the [Stationary Analysis of a Biased Resonator — 3D](#) model. In this example it is no longer possible to model half of the geometry using symmetry boundary conditions, because doing so excludes all the antisymmetric vibrational modes. The geometry is therefore mirrored prior to performing the analyses, as shown in [Figure 1](#). Note that the model could still be solved with the original geometry and symmetry boundary conditions, however the antisymmetric modes would be excluded from the solutions.

This model performs a modal analysis on the structure, with and without applied DC voltage biases of different magnitudes. The bias already exists as a parameter in the model so the prestressed eigenfrequency solver needs no adjustment to the physics settings. To compute the unbiased eigenfrequency, the solver settings are adjusted to solve only the structural mechanics problem.

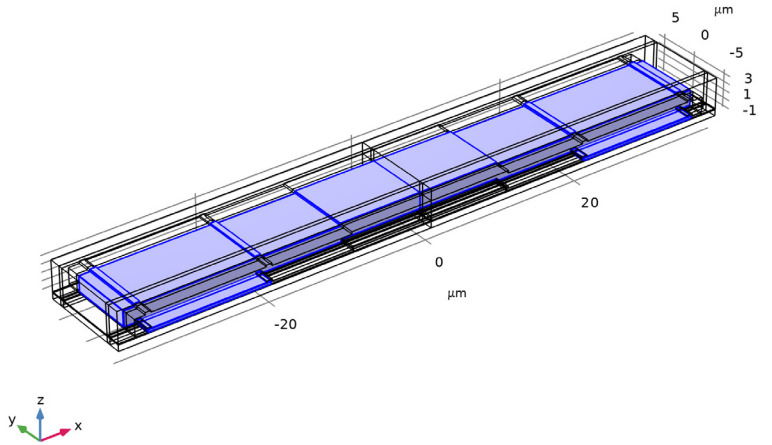

Figure 1: Model geometry. In order to capture the anti-symmetric vibrational modes, it is necessary to mirror the symmetric geometry prior to solving the model. The original symmetry plane is in the center of the geometry. The resonator itself is shown highlighted.

Results and Discussion

Figure 2 shows the normal modes of the device, together with the eigenfrequency, in the unbiased state. The lowest three normal modes are symmetric and anti-symmetric bending modes and a torsional mode.

The symmetric bending mode is employed during the operation of the device, and its shape does not change significantly with applied bias. However, the frequency of the mode is reduced significantly by the applied bias, an effect known as spring softening. The spring softening effect can be seen in detail in Figure 2. A clear decrease in the resonant frequency is evident with increasing bias voltage. This figure should be compared with Figure 16 of Ref. 1 which shows measured experimental data for the same device. Data extracted from Ref. 1 is shown in Figure 3 along with the simulation results. The agreement between the model and the data is excellent.

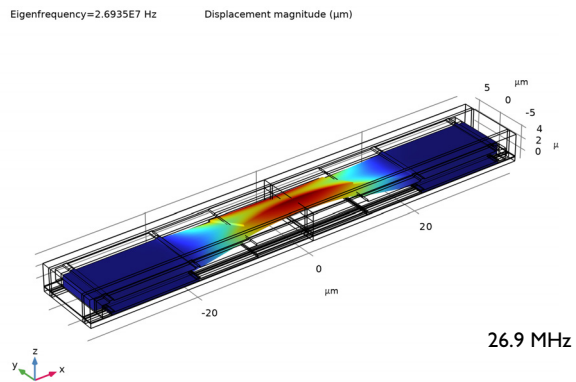
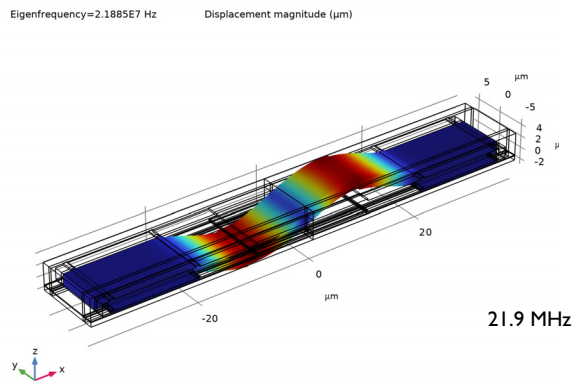
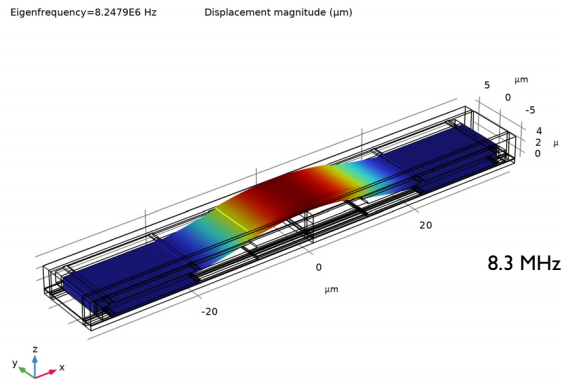

Figure 2: Normal modes of the unbiased device, together with the frequency of the mode.

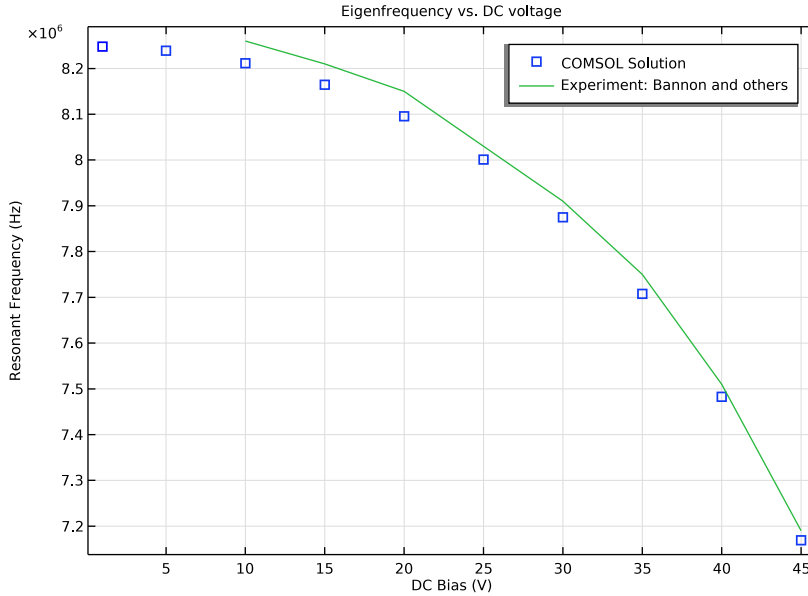

Figure 3: Resonant frequency of the first normal mode (a symmetric bending mode) as a function of applied DC bias. Both the COMSOL simulation data and the experimental data from Ref. 1 are shown in the plot.

Reference

1. F.D. Bannon III, J.R. Clark and C.T.-C. Nguyen, “High-Q HF Microelectromechanical Filters,” *IEEE Journal of Solid State Circuits*, vol. 35, no. 4, pp. 512–526, 2000.

Application Library path: MEMS_Module/Actuators/biased_resonator_3d_modes

Modeling Instructions

Open the existing stationary study (filename: biased_resonator_3d_basic.mph).

APPLICATION LIBRARIES

I From the **File** menu, choose **Application Libraries**.

2 In the **Application Libraries** window, select **MEMS Module > Actuators > biased_resonator_3d_basic** in the tree.

3 Click  **Open**.

Mirror the geometry so that asymmetric eigenmodes can be modeled.

GEOMETRY I

Mirror 1 (mir1)

1 In the **Model Builder** window, expand the **Component 1 (comp1)** node.

2 Right-click **Component 1 (comp1) > Geometry 1** and choose **Transforms > Mirror**.

3 In the **Settings** window for **Mirror**, locate the **Normal Vector to Plane of Reflection** section.

4 In the **z** text field, type 0.

5 In the **x** text field, type 1.

6 Click in the **Graphics** window and then press Ctrl+A to select both objects.

7 Locate the **Input** section. Select the **Keep input objects** checkbox.

8 Click  **Build All Objects**.

9 Click the  **Zoom Extents** button in the **Graphics** toolbar.

Import experimental data into the model for comparison with the simulation.

DEFINITIONS

Interpolation 1 (int1)

1 In the **Definitions** toolbar, click  **Interpolation**.

2 In the **Settings** window for **Interpolation**, locate the **Definition** section.

3 From the **Data source** list, choose **File**.

4 Click  **Browse**.

5 Browse to the model's Application Libraries folder and double-click the file `biased_resonator_3d_modes_experiment.txt`.

6 Click  **Import**.

7 Locate the **Units** section. In the **Argument** table, enter the following settings:

Argument	Unit
t	Hz

8 In the **Function** table, enter the following settings:

Function	Unit
int1	V

9 Locate the **Interpolation and Extrapolation** section. From the **Extrapolation** list, choose **Specific value**.

10 In the **Value outside range** text field, type NaN.

Disable the symmetry node to allow anti-symmetric nodes.

SOLID MECHANICS (SOLID)

Symmetry 1

1 In the **Model Builder** window, expand the **Component 1 (comp1) > Solid Mechanics (solid)** node.

2 Right-click **Component 1 (comp1) > Solid Mechanics (solid) > Symmetry 1** and choose **Disable**.

MESH 1

Size

1 In the **Model Builder** window, expand the **Component 1 (comp1) > Mesh 1** node, then click **Size**.

2 In the **Settings** window for **Size**, locate the **Element Size** section.

3 Click the **Custom** button.

4 Locate the **Element Size Parameters** section. In the **Minimum element size** text field, type 1.

5 Click  **Build All**.

ROOT

Add a study to compute the unbiased vibrational modes.

ADD STUDY

1 In the **Home** toolbar, click  **Add Study** to open the **Add Study** window.

2 Go to the **Add Study** window.

3 Find the **Studies** subsection. In the **Select Study** tree, select **Preset Studies for Selected Multiphysics > Eigenfrequency**.

4 Click the **Add Study** button in the window toolbar.

5 In the **Home** toolbar, click  **Add Study** to close the **Add Study** window.

STUDY 2

Solve for the first three modes.



Step 1: Eigenfrequency

- 1 In the **Model Builder** window, under **Study 2** click **Step 1: Eigenfrequency**.
- 2 In the **Settings** window for **Eigenfrequency**, locate the **Study Settings** section.
- 3 Select the **Desired number of eigenfrequencies** checkbox. In the associated text field, type 3.
- 4 Click to expand the **Store in Output** section. In the table, enter the following settings:

Interface	Output
Electrostatics (es)	None
Moving mesh (Component 1)	None

Disable the electric potential and mesh displacement degrees of freedom to solve only the structural problem. This will give the vibrational modes in the absence of an electric field.

Solution 2 (sol2)

- 1 In the **Study** toolbar, click  **Show Default Solver**.
- 2 In the **Model Builder** window, click **Study 2**.
- 3 In the **Settings** window for **Study**, type Unbiased Eigenfrequency in the **Label** text field.
- 4 Locate the **Study Settings** section. Clear the **Generate default plots** checkbox.
- 5 In the **Study** toolbar, click  **Compute**.

Change the dataset frame to show results in the material frame. This allows the use of the deformation plot attribute.

RESULTS

Unbiased Eigenfrequency/Solution 2 (sol2)

- 1 In the **Model Builder** window, expand the **Results > Datasets** node, then click **Unbiased Eigenfrequency/Solution 2 (sol2)**.
- 2 In the **Settings** window for **Solution**, locate the **Solution** section.
- 3 From the **Frame** list, choose **Material (X, Y, Z)**.

Create a plot that shows the unbiased modes.

3D Plot Group 5

- 1 In the **Results** toolbar, click  **3D Plot Group**.
- 2 In the **Settings** window for **3D Plot Group**, locate the **Data** section.
- 3 From the **Dataset** list, choose **Unbiased Eigenfrequency/Solution 2 (sol2)**.

Volume 1

- 1 Right-click **3D Plot Group 5** and choose **Volume**.
- 2 In the **Settings** window for **Volume**, click **Replace Expression** in the upper-right corner of the **Expression** section. From the menu, choose **Component 1 (comp1) > Solid Mechanics > Displacement > solid.disp - Displacement magnitude - m**.
- 3 Locate the **Coloring and Style** section. Clear the **Color legend** checkbox.



Deformation 1

Right-click **Volume 1** and choose **Deformation**.

Unbiased Modes

- 1 In the **Settings** window for **3D Plot Group**, type Unbiased Modes in the **Label** text field. Compare the mode shapes with those shown in [Figure 2](#) for all the modes computed. To switch between the modes click **Unbiased Modes** and choose a different value from the **Eigenfrequency** list. Add an **Eigenfrequency, Prestressed** study.

ADD STUDY



- 1 In the **Home** toolbar, click  **Add Study** to open the **Add Study** window.
- 2 Go to the **Add Study** window.
- 3 Find the **Studies** subsection. In the **Select Study** tree, select **Preset Studies for Selected Physics Interfaces > Solid Mechanics > Eigenfrequency, Prestressed**.
- 4 Click the **Add Study** button in the window toolbar.
- 5 In the **Home** toolbar, click  **Add Study** to close the **Add Study** window.

BIASED EIGENFREQUENCY

- 1 In the **Settings** window for **Study**, type Biased Eigenfrequency in the **Label** text field. Create a parametric sweep over DC bias voltage.

Parametric Sweep

- 1 In the **Study** toolbar, click  **Parametric Sweep**.
- 2 In the **Settings** window for **Parametric Sweep**, locate the **Study Settings** section.

- 3 Click  **Add**.
- 4 From the list in the **Parameter name** column, choose **Vcd (DC bias voltage)**.
- 5 Click  **Range**.
- 6 In the **Range** dialog, type 5 in the **Start** text field.
- 7 In the **Stop** text field, type 45.
- 8 In the **Step** text field, type 5.
- 9 Click **Add**.



Solve for only the first eigenfrequency.

Step 2: Eigenfrequency

- 1 In the **Model Builder** window, click **Step 2: Eigenfrequency**.
- 2 In the **Settings** window for **Eigenfrequency**, locate the **Study Settings** section.
- 3 Select the **Desired number of eigenfrequencies** checkbox. In the associated text field, type 1.

In this case automatic scaling for the dependent variables work best.

Solution 3 (sol3)

- 1 In the **Study** toolbar, click  **Show Default Solver**.
 - 2 In the **Model Builder** window, expand the **Solution 3 (sol3)** node.
 - 3 In the **Model Builder** window, expand the **Biased Eigenfrequency > Solver Configurations > Solution 3 (sol3) > Dependent Variables 2** node, then click **Spatial Mesh Displacement (comp1.spatial.disp)**.
 - 4 In the **Settings** window for **Field**, locate the **Scaling** section.
 - 5 From the **Method** list, choose **Automatic**.
 - 6 In the **Model Builder** window, under **Biased Eigenfrequency > Solver Configurations > Solution 3 (sol3) > Dependent Variables 2** click **Displacement Field (comp1.u)**.
 - 7 In the **Settings** window for **Field**, locate the **Scaling** section.
 - 8 From the **Method** list, choose **Automatic**.
- Disable the default plots.
- 9 In the **Model Builder** window, click **Biased Eigenfrequency**.
 - 10 In the **Settings** window for **Study**, locate the **Study Settings** section.
 - 11 Clear the **Generate default plots** checkbox.
 - 12 In the **Study** toolbar, click  **Compute**.

Create a plot of eigenfrequency versus applied DC voltage.

RESULTS

ID Plot Group 6

- 1 In the **Results** toolbar, click  **ID Plot Group**.
- 2 In the **Settings** window for **ID Plot Group**, locate the **Data** section.
- 3 From the **Dataset** list, choose **Biased Eigenfrequency/Parametric Solutions 1 (sol5)**.

Point Graph 1

- 1 Right-click **ID Plot Group 6** and choose **Point Graph**.
- 2 Select Point 1 only.
- 3 In the **Settings** window for **Point Graph**, locate the **y-Axis Data** section.
- 4 In the **Expression** text field, type `solid.freq`.
- 5 Locate the **x-Axis Data** section. From the **Axis source data** list, choose **Outer solutions**.
- 6 Click to expand the **Coloring and Style** section. Find the **Line style** subsection. From the **Line** list, choose **None**.
- 7 Find the **Line markers** subsection. From the **Marker** list, choose **Square**.
- 8 Click to expand the **Legends** section. Select the **Show legends** checkbox.
- 9 From the **Legends** list, choose **Manual**.
- 10 In the table, enter the following settings:

Legends

COMSOL Solution

Point Graph 2

- 1 Right-click **Point Graph 1** and choose **Duplicate**.
- 2 In the **Settings** window for **Point Graph**, locate the **Data** section.
- 3 From the **Dataset** list, choose **Unbiased Eigenfrequency/Solution 2 (sol2)**.
- 4 From the **Eigenfrequency selection** list, choose **First**.
- 5 Locate the **Coloring and Style** section. From the **Color** list, choose **Blue**.
- 6 Locate the **Legends** section. Clear the **Show legends** checkbox.

Global 1

- 1 In the **Model Builder** window, right-click **ID Plot Group 6** and choose **Global**.
- 2 In the **Settings** window for **Global**, locate the **Data** section.
- 3 From the **Dataset** list, choose **Biased Eigenfrequency/Parametric Solutions 1 (sol5)**.
- 4 From the **Parameter selection (Vdc)** list, choose **From list**.

- 5 In the **Parameter values (Vdc (V))** list, choose **10, 15, 20, 25, 30, 35, 40,** and **45.**
- 6 Locate the **y-Axis Data** section. In the table, enter the following settings:

Expression	Unit	Description
int1 (Vdc)		

- 7 Locate the **x-Axis Data** section. From the **Axis source data** list, choose **Outer solutions.**
- 8 From the **Parameter** list, choose **Expression.**
- 9 In the **Expression** text field, type **Vdc.**
- 10 Click to expand the **Legends** section. From the **Legends** list, choose **Manual.**
- 11 In the table, enter the following settings:

Legends
Experiment: Bannon and others

Eigenfrequency vs. DC Voltage

- 1 In the **Model Builder** window, click **ID Plot Group 6.**
- 2 In the **Settings** window for **ID Plot Group**, click to expand the **Title** section.
- 3 From the **Title type** list, choose **Manual.**
- 4 In the **Title** text area, type **Eigenfrequency vs. DC voltage.**
- 5 Locate the **Plot Settings** section.
- 6 Select the **x-axis label** checkbox. In the associated text field, type **DC Bias (V).**
- 7 Select the **y-axis label** checkbox. In the associated text field, type **Resonant Frequency (Hz).**
- 8 In the **Label** text field, type **Eigenfrequency vs. DC Voltage.**
Compare this plot with that in [Figure 3](#). Note the spring softening effect.