



Model created in COMSOL Multiphysics 6.4

Stationary Analysis of a Biased Resonator – 3D

Introduction

Silicon micromechanical resonators have long been used for designing sensors and are now becoming increasingly important as oscillators in the consumer electronics market. This sequence of models analyzes in detail a surface micromachined MEMS resonator, designed as part of a micromechanical filter. The resonator is based on that developed in [Ref. 1](#).

This model performs a stationary analysis of the resonator, with an applied DC bias. It serves as a basis for all the subsequent analyses.

Model Definition

The model consists of a poly-silicon resonator, which is manufactured through a surface micromachining process. Initially, a silicon wafer is coated with 0.75 μm of oxide and 0.15 μm of silicon nitride to isolate the micromachined parts from the wafer ground plane. Polysilicon electrodes with a thickness of 0.3 μm are deposited next. A sacrificial layer of oxide is then deposited to a thickness of 198.5 nm. Note that in [Ref. 1](#) the sacrificial oxide is actually 1.3 μm , but the gap thickness was adjusted to this value for the purposes of simulation to account for the depletion layer in the silicon. This model uses the same adjustment to enable the simulations to be directly compared with those presented in the paper. Holes are etched in the sacrificial layer (to provide anchor points for the resonator) and the structural polysilicon is deposited with a thickness of 1.9 μm .

The structure has a plane of symmetry, so it is possible to model only half of the geometry explicitly, although care must be taken to mirror the geometry before performing a modal analysis. [Figure 1](#) shows the geometry.

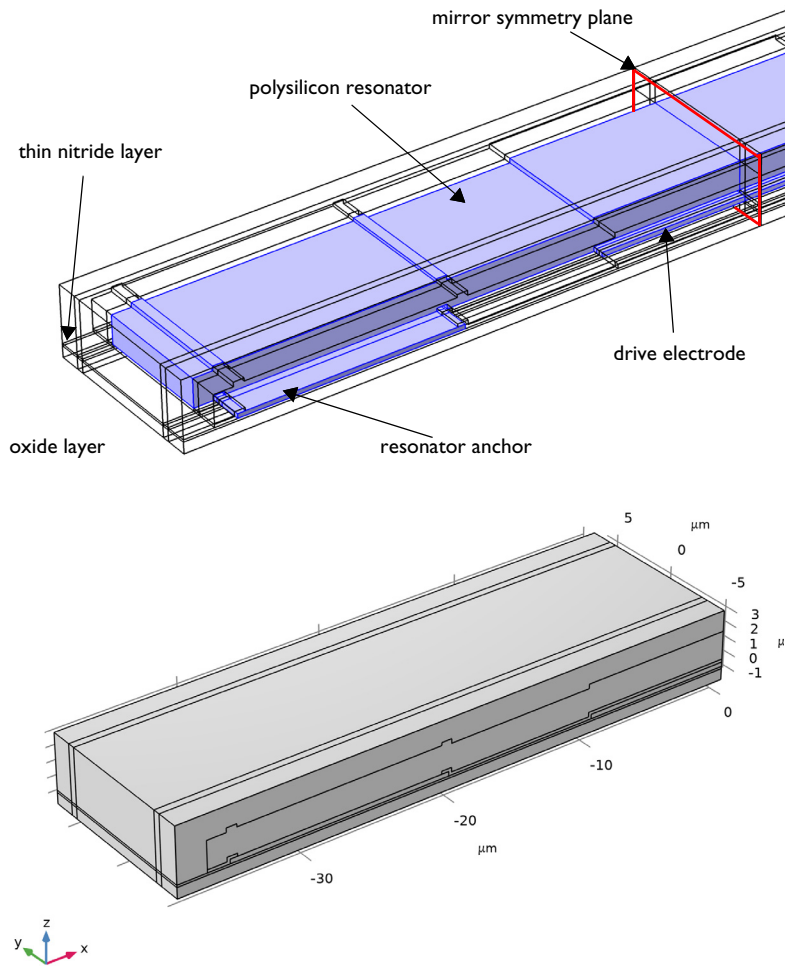

Figure 1: Top: Device geometry. The wafer itself is not shown explicitly, but is represented in the model by a ground plane on the underside of the geometry. Bottom: The model geometry as it appears in COMSOL.

The layers of deposited material from the ground plane up are: silicon oxide, silicon nitride (too thin to see clearly), polysilicon electrodes/air gap (etched sacrificial oxide), polysilicon resonator, and air.

In operation, both the silicon resonator and the underlying wafer are grounded and an electric voltage is applied to the driving electrode, which is bisected by the symmetry plane.

Typically a DC bias of 35 V is applied in normal operation of the device. The assumption is made that the polysilicon is a perfect conductor, so the bias voltage can be applied on the resonator using the **Domain Terminal** feature, which is much easier than selecting the many boundaries for setting the electric potential on them.

In this model, the deformation of the structure is computed with the applied DC bias. Note that the silicon oxide and nitride are assumed to be rigid for the solid mechanics simulations, so the structure is anchored at the base of its electrode, and these domains are not included in the solid mechanics equations.

ELECTROMECHANICS COUPLING

Within a vacuum or other medium, forces between charged bodies can be computed on the assumption that a fictitious state of stress exists within the field. The Electromagnetic or Maxwell stress tensor can be used to compute the induced stresses in a material as a result of an electric field as well as surface forces acting on bodies in air or vacuum. In this model, it is assumed that the polysilicon is doped sufficiently heavily that it can be treated as a perfect conductor. The electric field is assumed to be zero inside the resonator, which means that the Maxwell stress tensor is zero inside the material and there are no volumetric electrical forces. The Maxwell stress tensor in the medium surrounding the resonator, where the electric field is nonzero is (Ref. 2)

$$T_{EM, V} = -\frac{1}{2}(\mathbf{E} \cdot \mathbf{D})\mathbf{I} + \mathbf{E}\mathbf{D}^T$$

A net force on the surface typically results from the discontinuity of the stress tensor at the interface. However, because it is undesirable to apply a stress term throughout the vacuum, the force is only computed on the surface of the resonator, and is applied by the **Electromechanics** coupling. The surface force is given by

$$\mathbf{n}_1 T_{EM, V} = -\left(\frac{1}{2}\mathbf{E} \cdot \mathbf{D}\right)\mathbf{n}_1 + (\mathbf{n}_1 \cdot \mathbf{E})\mathbf{D}$$

where \mathbf{n}_1 is the surface normal, pointing out from the mechanical body.

Results and Discussion

Figure 2 shows the z displacement of the structure with an applied DC bias. As expected the structural displacement is maximal on the symmetry plane at the center of the device. The maximum displacement is 13 nm. Electric potential isosurfaces are also shown in Figure 2. As expected, the isobars are uniformly distributed and closest together between the resonator and the electrode. This corresponds to a region of uniform electric field.

Around the electrode the fringing fields can also be seen. Note that the surface of the resonator is assumed to be perfectly grounded. This is a result of the potential boundary condition used and is equivalent to the assumption that the polysilicon is a perfect conductor.

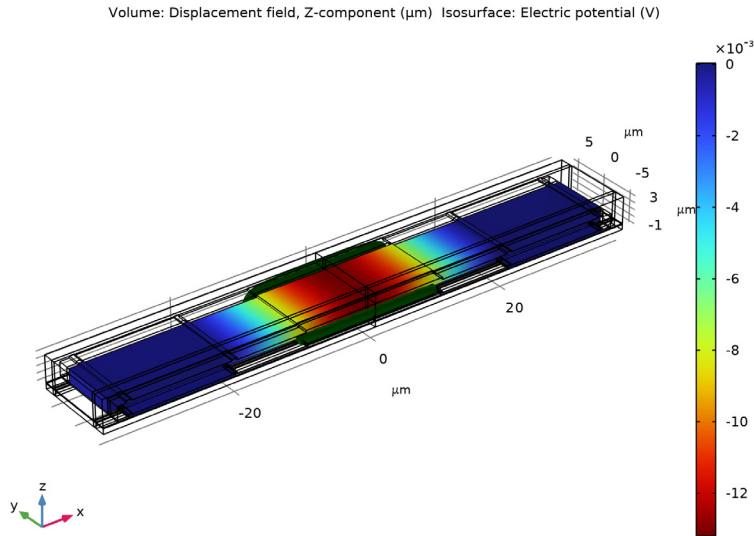

Figure 2: The z-displacement of the resonator as a function of position. The maximum displacement occurs in the center of the resonator, immediately over the biasing electrode. Electric potential isosurfaces with values of 10 V (green), 20 V (yellow), and 30 V (red) are also shown.

References

1. F.D. Bannon, J.R. Clark, and C.T.-C. Nguyen, “High-Q HF Microelectromechanical Filters,” *IEEE J. Solid State Circuits*, vol. 35, no. 4, pp. 512–526, 2000.
2. J.A. Stratton, *Electromagnetic Theory*, McGraw Hill, New York, 1941.

Application Library path: MEMS_Module/Actuators/biased_resonator_3d_basic



Modeling Instructions

From the **File** menu, choose **New**.

NEW



In the **New** window, click  **Model Wizard**.

MODEL WIZARD

- 1 In the **Model Wizard** window, click  **3D**.
- 2 In the **Select Physics** tree, select **Structural Mechanics > Electromagnetics-Structure Interaction > Electromechanics > Electromechanics, Solid**.
- 3 Click **Add**.
- 4 Click  **Study**.
- 5 In the **Select Study** tree, select **General Studies > Stationary**.
- 6 Click  **Done**.

GEOMETRY I

For convenience, the device geometry is inserted from an existing file. You can read the instructions for creating the geometry in the [Appendix — Geometry Modeling Instructions](#).

- 1 In the **Geometry** toolbar, click **Insert Sequence** and choose **Insert Sequence**.
- 2 Browse to the model's Application Libraries folder and double-click the file `biased_resonator_3d_geom_sequence.mph`.
- 3 In the **Geometry** toolbar, click  **Build All**.
- 4 Click the  **Zoom Extents** button in the **Graphics** toolbar.

Add a parameter for the applied DC bias.

GLOBAL DEFINITIONS

Parameters I

- 1 In the **Model Builder** window, under **Global Definitions** click **Parameters I**.
- 2 In the **Settings** window for **Parameters**, locate the **Parameters** section.

3 In the table, enter the following settings:

Name	Expression	Value	Description
Vdc	35[V]	35 V	DC bias voltage

Create selections to facilitate easy setup of the boundary conditions.

DEFINITIONS

All domains

- 1 In the **Definitions** toolbar, click  **Explicit**.
- 2 In the **Settings** window for **Explicit**, locate the **Input Entities** section.
- 3 Select the **All domains** checkbox.
- 4 In the **Label** text field, type All domains.

Ground Plane

- 1 In the **Definitions** toolbar, click  **Box**.
- 2 In the **Settings** window for **Box**, locate the **Box Limits** section.
- 3 In the **z minimum** text field, type -2.
- 4 In the **z maximum** text field, type -1.
- 5 Locate the **Output Entities** section. From the **Include entity if** list, choose **Entity inside box**.
- 6 Locate the **Geometric Entity Level** section. From the **Level** list, choose **Boundary**.
- 7 In the **Label** text field, type Ground Plane.

Oxide

- 1 In the **Definitions** toolbar, click  **Box**.
- 2 In the **Settings** window for **Box**, locate the **Box Limits** section.
- 3 In the **z minimum** text field, type -1.
- 4 In the **z maximum** text field, type -0.9.
- 5 In the **Label** text field, type Oxide.

Nitride

- 1 In the **Definitions** toolbar, click  **Box**.
- 2 In the **Settings** window for **Box**, locate the **Box Limits** section.
- 3 In the **z minimum** text field, type -0.4.
- 4 In the **z maximum** text field, type -0.35.

5 In the **Label** text field, type Nitride.

Electrode

- 1 In the **Definitions** toolbar, click  **Box**.
- 2 In the **Settings** window for **Box**, locate the **Box Limits** section.
- 3 In the **x minimum** text field, type -0.1.
- 4 In the **x maximum** text field, type 0.1.
- 5 In the **y minimum** text field, type -4.2.
- 6 In the **z minimum** text field, type -0.15.
- 7 In the **z maximum** text field, type -0.1.
- 8 In the **Label** text field, type Electrode.

Ball 1

- 1 In the **Definitions** toolbar, click  **Ball/Disk**.
- 2 In the **Settings** window for **Ball**, locate the **Ball Center** section.
- 3 In the **z** text field, type 1.
- 4 Locate the **Ball Radius** section. In the **Radius** text field, type 0.1.

Box 5



- 1 In the **Definitions** toolbar, click  **Box**.
- 2 In the **Settings** window for **Box**, locate the **Box Limits** section.
- 3 In the **y maximum** text field, type 4.8.
- 4 In the **z minimum** text field, type -0.35.
- 5 In the **z maximum** text field, type 0.05.
- 6 Locate the **Output Entities** section. From the **Include entity if** list, choose **Entity inside box**.

Box 6



- 1 Right-click **Box 5** and choose **Duplicate**.
- 2 In the **Settings** window for **Box**, locate the **Box Limits** section.
- 3 In the **x minimum** text field, type -15.
- 4 In the **x maximum** text field, type 15.

Resonator



- 1 In the **Definitions** toolbar, click  **Difference**.
- 2 In the **Settings** window for **Difference**, locate the **Input Entities** section.

- 3 Under **Selections to add**, click  **Add**.
- 4 In the **Add** dialog, in the **Selections to add** list, choose **Ball 1** and **Box 5**.
- 5 Click **OK**.
- 6 In the **Settings** window for **Difference**, locate the **Input Entities** section.
- 7 Under **Selections to subtract**, click  **Add**.
- 8 In the **Add** dialog, select **Box 6** in the **Selections to subtract** list.
- 9 Click **OK**.
- 10 In the **Settings** window for **Difference**, type Resonator in the **Label** text field.



PolySi

- 1 In the **Definitions** toolbar, click  **Union**.
- 2 In the **Settings** window for **Union**, locate the **Input Entities** section.
- 3 Under **Selections to add**, click  **Add**.
- 4 In the **Add** dialog, in the **Selections to add** list, choose **Electrode** and **Resonator**.
- 5 Click **OK**.
- 6 In the **Settings** window for **Union**, type PolySi in the **Label** text field.

Air

- 1 In the **Definitions** toolbar, click  **Difference**.
- 2 In the **Settings** window for **Difference**, locate the **Input Entities** section.
- 3 Under **Selections to add**, click  **Add**.
- 4 In the **Add** dialog, select **All domains** in the **Selections to add** list.
- 5 Click **OK**.
- 6 In the **Settings** window for **Difference**, locate the **Input Entities** section.
- 7 Under **Selections to subtract**, click  **Add**.
- 8 In the **Add** dialog, in the **Selections to subtract** list, choose **Oxide**, **Nitride**, and **PolySi**.
- 9 Click **OK**.
- 10 In the **Settings** window for **Difference**, type Air in the **Label** text field.

Resonator Boundaries

- 1 In the **Definitions** toolbar, click  **Adjacent**.
- 2 In the **Settings** window for **Adjacent**, locate the **Input Entities** section.
- 3 Under **Input selections**, click  **Add**.
- 4 In the **Add** dialog, select **Resonator** in the **Input selections** list.

5 Click **OK**.

6 In the **Settings** window for **Adjacent**, type Resonator Boundaries in the **Label** text field.

Electrode Boundaries

1 In the **Definitions** toolbar, click  **Adjacent**.

2 In the **Settings** window for **Adjacent**, locate the **Input Entities** section.

3 Under **Input selections**, click  **Add**.

4 In the **Add** dialog, select **Electrode** in the **Input selections** list.

5 Click **OK**.

6 In the **Settings** window for **Adjacent**, type Electrode Boundaries in the **Label** text field.

Nitride Boundaries

1 In the **Definitions** toolbar, click  **Adjacent**.

2 In the **Settings** window for **Adjacent**, locate the **Input Entities** section.

3 Under **Input selections**, click  **Add**.

4 In the **Add** dialog, select **Nitride** in the **Input selections** list.

5 Click **OK**.

6 In the **Settings** window for **Adjacent**, type Nitride Boundaries in the **Label** text field.

Geometry Exterior Boundaries

1 In the **Definitions** toolbar, click  **Adjacent**.

2 In the **Settings** window for **Adjacent**, locate the **Input Entities** section.

3 Under **Input selections**, click  **Add**.

4 In the **Add** dialog, select **All domains** in the **Input selections** list.

5 Click **OK**.

6 In the **Settings** window for **Adjacent**, type Geometry Exterior Boundaries in the **Label** text field.

Resonator Exterior Boundaries

1 In the **Definitions** toolbar, click  **Difference**.

2 In the **Settings** window for **Difference**, locate the **Geometric Entity Level** section.



3 From the **Level** list, choose **Boundary**.

4 Locate the **Input Entities** section. Under **Selections to add**, click  **Add**.



5 In the **Add** dialog, select **Resonator Boundaries** in the **Selections to add** list.

- 6 Click **OK**.
- 7 In the **Settings** window for **Difference**, locate the **Input Entities** section.
- 8 Under **Selections to subtract**, click  **Add**.
- 9 In the **Add** dialog, select **Geometry Exterior Boundaries** in the **Selections to subtract** list.
- 10 Click **OK**.
- 11 In the **Settings** window for **Difference**, type Resonator Exterior Boundaries in the **Label** text field.

Electrode Exterior Boundaries

- 1 In the **Definitions** toolbar, click  **Difference**.
- 2 In the **Settings** window for **Difference**, locate the **Geometric Entity Level** section.
- 3 From the **Level** list, choose **Boundary**.
- 4 Locate the **Input Entities** section. Under **Selections to add**, click  **Add**.
- 5 In the **Add** dialog, select **Electrode Boundaries** in the **Selections to add** list.
- 6 Click **OK**.
- 7 In the **Settings** window for **Difference**, locate the **Input Entities** section.
- 8 Under **Selections to subtract**, click  **Add**.
- 9 In the **Add** dialog, select **Geometry Exterior Boundaries** in the **Selections to subtract** list.
- 10 Click **OK**.
- 11 In the **Settings** window for **Difference**, type Electrode Exterior Boundaries in the **Label** text field.

Fixed Boundaries

- 1 In the **Definitions** toolbar, click  **Intersection**.
- 2 In the **Settings** window for **Intersection**, locate the **Geometric Entity Level** section.
- 3 From the **Level** list, choose **Boundary**.
- 4 Locate the **Input Entities** section. Under **Selections to intersect**, click  **Add**.
- 5 In the **Add** dialog, in the **Selections to intersect** list, choose **Resonator Boundaries** and **Nitride Boundaries**.
- 6 Click **OK**.
- 7 In the **Settings** window for **Intersection**, type Fixed Boundaries in the **Label** text field.

Symmetry Boundaries



- 1 In the **Definitions** toolbar, click  **Box**.
- 2 In the **Settings** window for **Box**, locate the **Geometric Entity Level** section.

- 3 From the **Level** list, choose **Boundary**.
- 4 Locate the **Box Limits** section. In the **x minimum** text field, type -0.1.
- 5 In the **x maximum** text field, type 0.1.
- 6 Locate the **Output Entities** section. From the **Include entity if** list, choose **Entity inside box**.
- 7 In the **Label** text field, type Symmetry Boundaries.

MATERIALS

Add materials to the model.

ADD MATERIAL

- 1 In the **Materials** toolbar, click  **Add Material** to open the **Add Material** window.
- 2 Go to the **Add Material** window.
- 3 In the tree, select **MEMS > Semiconductors > Si - Polycrystalline silicon**.
- 4 Click the **Add to Component** button in the window toolbar.
- 5 In the tree, select **MEMS > Insulators > Si3N4 - Silicon nitride**.
- 6 Click the **Add to Component** button in the window toolbar.
- 7 In the tree, select **MEMS > Insulators > SiO2 - Silicon oxide**.
- 8 Click the **Add to Component** button in the window toolbar.
- 9 In the **Materials** toolbar, click  **Add Material** to close the **Add Material** window.

MATERIALS

Si - Polycrystalline silicon (mat1)

- 1 In the **Settings** window for **Material**, locate the **Geometric Entity Selection** section.
- 2 From the **Selection** list, choose **PolySi**.

Si3N4 - Silicon nitride (mat2)

- 1 In the **Model Builder** window, click **Si3N4 - Silicon nitride (mat2)**.
- 2 In the **Settings** window for **Material**, locate the **Geometric Entity Selection** section.
- 3 From the **Selection** list, choose **Nitride**.

SiO2 - Silicon oxide (mat3)

- 1 In the **Model Builder** window, click **SiO2 - Silicon oxide (mat3)**.
- 2 In the **Settings** window for **Material**, locate the **Geometric Entity Selection** section.
- 3 From the **Selection** list, choose **Oxide**.

SOLID MECHANICS (SOLID)

- 1 In the **Model Builder** window, under **Component 1 (comp1)** click **Solid Mechanics (solid)**.
- 2 In the **Settings** window for **Solid Mechanics**, locate the **Domain Selection** section.
- 3 From the **Selection** list, choose **Resonator**.

Fixed Constraint 1

- 1 In the **Physics** toolbar, click  **Boundaries** and choose **Fixed Constraint**.
- 2 In the **Settings** window for **Fixed Constraint**, locate the **Boundary Selection** section.
- 3 From the **Selection** list, choose **Fixed Boundaries**.

Symmetry 1

- 1 In the **Physics** toolbar, click  **Boundaries** and choose **Symmetry**.
- 2 In the **Settings** window for **Symmetry**, locate the **Boundary Selection** section.
- 3 From the **Selection** list, choose **Symmetry Boundaries**.

MOVING MESH

Deforming Domain 1

- 1 In the **Model Builder** window, under **Component 1 (comp1)** > **Moving Mesh** click **Deforming Domain 1**.
- 2 In the **Settings** window for **Deforming Domain**, locate the **Domain Selection** section.
- 3 From the **Selection** list, choose **Air**.

Symmetry/Roller 1

- 1 In the **Model Builder** window, click **Symmetry/Roller 1**.
- 2 In the **Settings** window for **Symmetry/Roller**, locate the **Boundary Selection** section.
- 3 From the **Selection** list, choose **Symmetry Boundaries**.

ELECTROSTATICS (ES)

Charge Conservation in Solids 1

- 1 In the **Model Builder** window, under **Component 1 (comp1)** > **Electrostatics (es)** click **Charge Conservation in Solids 1**.
- 2 In the **Settings** window for **Charge Conservation in Solids**, locate the **Domain Selection** section.
- 3 Click  **Clear Selection**.
- 4 Select Domains 1, 2, 4, 5, 7, 8, 10, 11, 13, and 14 only.

With the assumption that the silicon material is a good conductor, use the **Domain Terminal** feature to ground the resonator. Note: The **Domain Terminal** feature is very handy in this case, where the conducting domain has a complex shape with many exterior surfaces - instead of selecting all the boundaries to set up the ground, terminal, or electric potential boundary condition, we only need to select the domain to specify the **Domain Terminal** feature with the same effect. In addition, the computation load is reduced, because the electrostatic degrees of freedom within the **Domain Terminal** do not need to be solved for.

Domain Terminal 1

- 1 In the **Physics** toolbar, click  **Domains** and choose **Domain Terminal**.
- 2 In the **Settings** window for **Domain Terminal**, locate the **Domain Selection** section.
- 3 From the **Selection** list, choose **Resonator**.
- 4 Locate the **Terminal** section. From the **Terminal type** list, choose **Voltage**.
- 5 In the V_0 text field, type 0.

Ground 1

- 1 In the **Physics** toolbar, click  **Boundaries** and choose **Ground**.
- 2 In the **Settings** window for **Ground**, locate the **Boundary Selection** section.
- 3 From the **Selection** list, choose **Ground Plane**.



Use the domain **Terminal** feature to specify a bias voltage for the electrode domain.

Domain Terminal 2

- 1 In the **Physics** toolbar, click  **Domains** and choose **Domain Terminal**.
- 2 In the **Settings** window for **Domain Terminal**, locate the **Domain Selection** section.
- 3 From the **Selection** list, choose **Electrode**.
- 4 Locate the **Terminal** section. From the **Terminal type** list, choose **Voltage**.
- 5 In the V_0 text field, type V_{dc} .

MESH 1

Free Triangular 1

- 1 In the **Mesh** toolbar, click  **More Generators** and choose **Free Triangular**.
- 2 In the **Settings** window for **Free Triangular**, locate the **Boundary Selection** section.
- 3 From the **Selection** list, choose **Free Triangular Mesh**.
- 4 Click  **Build Selected**.

Swept 1

- 1 In the **Mesh** toolbar, click  **Swept**.
- 2 In the **Settings** window for **Swept**, click  **Build Selected**.

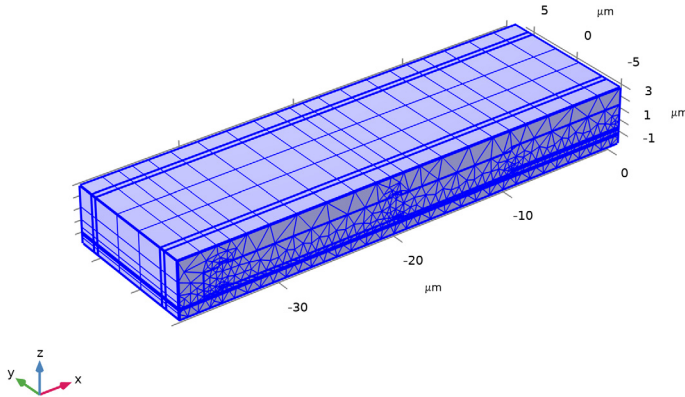

STATIONARY

- 1 In the **Model Builder** window, right-click **Study 1** and choose **Rename**.
- 2 In the **Rename Study** dialog, type **Stationary** in the **New label** text field.
- 3 Click **OK**.
- 4 In the **Study** toolbar, click  **Compute**.

RESULTS

Mirror 3D 1

In the **Results** toolbar, click  **More Datasets** and choose **Mirror 3D**.

Moving Mesh

In the **Model Builder** window, under **Results** right-click **Moving Mesh** and choose **Delete**.

3D Plot Group 4

- 1 In the **Results** toolbar, click  **3D Plot Group**.
- 2 In the **Settings** window for **3D Plot Group**, locate the **Data** section.
- 3 From the **Dataset** list, choose **Mirror 3D 1**.

Volume 1

- 1 Right-click **3D Plot Group 4** and choose **Volume**.
- 2 In the **Settings** window for **Volume**, click **Replace Expression** in the upper-right corner of the **Expression** section. From the menu, choose **Component 1 (comp1) > Solid Mechanics > Displacement > Displacement field - m > w - Displacement field, Z-component**.
- 3 Locate the **Coloring and Style** section. From the **Color table transformation** list, choose **Reverse**.

Isosurface 1

- 1 In the **Model Builder** window, right-click **3D Plot Group 4** and choose **Isosurface**.
- 2 In the **Settings** window for **Isosurface**, click **Replace Expression** in the upper-right corner of the **Expression** section. From the menu, choose **Component 1 (comp1) > Electrostatics > Electric > V - Electric potential - V**.
- 3 Locate the **Levels** section. From the **Entry method** list, choose **Levels**.
- 4 In the **Levels** text field, type 10 20 30.
- 5 Locate the **Coloring and Style** section. From the **Color table** list, choose **Traffic**.
- 6 Clear the **Color legend** checkbox.

Biased Displacement

- 1 In the **Model Builder** window, under **Results** click **3D Plot Group 4**.
- 2 In the **Settings** window for **3D Plot Group**, type Biased Displacement in the **Label** text field.
Compare the resulting plot with [Figure 2](#).

Appendix — Geometry Modeling Instructions

From the **File** menu, choose **New**.

NEW

In the **New** window, click  **Blank Model**.

ADD COMPONENT

In the **Home** toolbar, click  **Add Component** and choose **3D**.

GEOMETRY 1

- 1 In the **Settings** window for **Geometry**, locate the **Units** section.
- 2 From the **Length unit** list, choose **µm**.

Block 1 (blk1)

- 1 In the **Geometry** toolbar, click  **Block**.
- 2 In the **Settings** window for **Block**, locate the **Size and Shape** section.
- 3 In the **Width** text field, type 38.9.
- 4 In the **Depth** text field, type 12.
- 5 In the **Height** text field, type 4.7.
- 6 Locate the **Position** section. In the **x** text field, type -38.9.
- 7 In the **y** text field, type -6.
- 8 In the **z** text field, type -1.2.
- 9 Click to expand the **Layers** section. In the table, enter the following settings:

Layer name	Thickness (μm)
Layer 1	1.5
Layer 2	0.5

- 10 Find the **Layer position** subsection. Select the **Front** checkbox.
- 11 Select the **Back** checkbox.
- 12 Clear the **Bottom** checkbox.

Work Plane 1 (wpl)

- 1 In the **Geometry** toolbar, click  **Work Plane**.
- 2 In the **Settings** window for **Work Plane**, locate the **Plane Definition** section.
- 3 From the **Plane** list, choose **zx-plane**.
- 4 In the **y-coordinate** text field, type -6.

Work Plane 1 (wpl) > Plane Geometry

In the **Model Builder** window, click **Plane Geometry**.

Work Plane 1 (wpl) > Rectangle 1 (r1)

- 1 In the **Work Plane** toolbar, click  **Rectangle**.
- 2 In the **Settings** window for **Rectangle**, locate the **Size and Shape** section.
- 3 In the **Width** text field, type 0.15.
- 4 In the **Height** text field, type 38.9.
- 5 Locate the **Position** section. In the **xw** text field, type -0.45.
- 6 In the **yw** text field, type -38.9.

Work Plane 1 (wp1) > Rectangle 2 (r2)

- 1 In the **Work Plane** toolbar, click  **Rectangle**.
- 2 In the **Settings** window for **Rectangle**, locate the **Size and Shape** section.
- 3 In the **Width** text field, type 0.2.
- 4 In the **Height** text field, type 1.5.
- 5 Locate the **Position** section. In the **xw** text field, type -0.3.
- 6 In the **yw** text field, type -36.9.

Work Plane 1 (wp1) > Rectangle 3 (r3)

- 1 In the **Work Plane** toolbar, click  **Rectangle**.
- 2 In the **Settings** window for **Rectangle**, locate the **Size and Shape** section.
- 3 In the **Width** text field, type 1.9.
- 4 In the **Height** text field, type 1.3.
- 5 Locate the **Position** section. In the **xw** text field, type -0.1.
- 6 In the **yw** text field, type -36.9.

Work Plane 1 (wp1) > Rectangle 4 (r4)

- 1 In the **Work Plane** toolbar, click  **Rectangle**.
- 2 In the **Settings** window for **Rectangle**, locate the **Size and Shape** section.
- 3 In the **Width** text field, type 1.9.
- 4 In the **Height** text field, type 0.7.
- 5 Locate the **Position** section. In the **xw** text field, type 0.2.
- 6 In the **yw** text field, type -35.6.

Work Plane 1 (wp1) > Rectangle 5 (r5)

- 1 In the **Work Plane** toolbar, click  **Rectangle**.
- 2 In the **Settings** window for **Rectangle**, locate the **Size and Shape** section.
- 3 In the **Width** text field, type 1.9.
- 4 In the **Height** text field, type 14.
- 5 Locate the **Position** section. In the **yw** text field, type -34.9.

Work Plane 1 (wp1) > Rectangle 6 (r6)

- 1 In the **Work Plane** toolbar, click  **Rectangle**.
- 2 In the **Settings** window for **Rectangle**, locate the **Size and Shape** section.
- 3 In the **Width** text field, type 1.9.

- 4 In the **Height** text field, type 0.7.
- 5 Locate the **Position** section. In the **xw** text field, type 0.2.
- 6 In the **yw** text field, type -20.9.

Work Plane 1 (wp1) > Rectangle 7 (r7)

- 1 In the **Work Plane** toolbar, click  **Rectangle**.
- 2 In the **Settings** window for **Rectangle**, locate the **Size and Shape** section.
- 3 In the **Width** text field, type 0.2.
- 4 In the **Height** text field, type 0.7.
- 5 Locate the **Position** section. In the **yw** text field, type -20.9.

Work Plane 1 (wp1) > Rectangle 8 (r8)

- 1 In the **Work Plane** toolbar, click  **Rectangle**.
- 2 In the **Settings** window for **Rectangle**, locate the **Size and Shape** section.
- 3 In the **Width** text field, type 1.9.
- 4 In the **Height** text field, type 10.
- 5 Locate the **Position** section. In the **xw** text field, type -0.1.
- 6 In the **yw** text field, type -20.2.

Work Plane 1 (wp1) > Rectangle 9 (r9)

- 1 In the **Work Plane** toolbar, click  **Rectangle**.
- 2 In the **Settings** window for **Rectangle**, locate the **Size and Shape** section.
- 3 In the **Width** text field, type 0.2.
- 4 In the **Height** text field, type 10.4.
- 5 Locate the **Position** section. In the **xw** text field, type -0.3.
- 6 In the **yw** text field, type -20.4.

Work Plane 1 (wp1) > Rectangle 10 (r10)

- 1 In the **Work Plane** toolbar, click  **Rectangle**.
- 2 In the **Settings** window for **Rectangle**, locate the **Size and Shape** section.
- 3 In the **Width** text field, type 0.3.
- 4 In the **Height** text field, type 0.2.
- 5 Locate the **Position** section. In the **xw** text field, type -0.1.
- 6 In the **yw** text field, type -10.2.

Work Plane 1 (wp1) > Rectangle 11 (r11)

- 1 In the **Work Plane** toolbar, click  **Rectangle**.
- 2 In the **Settings** window for **Rectangle**, locate the **Size and Shape** section.
- 3 In the **Width** text field, type 0.2.
- 4 In the **Height** text field, type 10.
- 5 Locate the **Position** section. In the **yw** text field, type -10.

Work Plane 1 (wp1) > Rectangle 12 (r12)

- 1 In the **Work Plane** toolbar, click  **Rectangle**.
- 2 In the **Settings** window for **Rectangle**, locate the **Size and Shape** section.
- 3 In the **Width** text field, type 1.9.
- 4 In the **Height** text field, type 10.2.
- 5 Locate the **Position** section. In the **xw** text field, type 0.2.
- 6 In the **yw** text field, type -10.2.

Work Plane 1 (wp1) > Rectangle 13 (r13)

- 1 In the **Work Plane** toolbar, click  **Rectangle**.
- 2 In the **Settings** window for **Rectangle**, locate the **Size and Shape** section.
- 3 In the **Width** text field, type 0.1.
- 4 In the **Height** text field, type 0.2.
- 5 Locate the **Position** section. In the **xw** text field, type -0.1.
- 6 In the **yw** text field, type -20.4.

Work Plane 1 (wp1) > Rectangle 14 (r14)

- 1 In the **Work Plane** toolbar, click  **Rectangle**.
- 2 In the **Settings** window for **Rectangle**, locate the **Size and Shape** section.
- 3 In the **Width** text field, type 0.3.
- 4 In the **Height** text field, type 0.2.
- 5 Locate the **Position** section. In the **xw** text field, type -0.1.
- 6 In the **yw** text field, type -35.6.

Work Plane 1 (wp1) > Rectangle 15 (r15)

- 1 In the **Work Plane** toolbar, click  **Rectangle**.
- 2 In the **Settings** window for **Rectangle**, locate the **Size and Shape** section.
- 3 In the **Width** text field, type 0.2.

- 4 In the **Height** text field, type 0.5.
- 5 Locate the **Position** section. In the **yw** text field, type -35.4.

Work Plane 1 (wp1) > Union 1 (uni1)

- 1 In the **Work Plane** toolbar, click  **Booleans and Partitions** and choose **Union**.
- 2 Select the objects **r12, r3, r4, r5, r6, and r8** only.
- 3 In the **Settings** window for **Union**, locate the **Union** section.
- 4 Clear the **Keep interior boundaries** checkbox.

Work Plane 1 (wp1) > Union 2 (uni2)

- 1 In the **Work Plane** toolbar, click  **Booleans and Partitions** and choose **Union**.
- 2 Select the objects **r10, r11, r13, r14, r15, r2, r7, and r9** only.
- 3 In the **Settings** window for **Union**, locate the **Union** section.
- 4 Clear the **Keep interior boundaries** checkbox.

Extrude 1 (ext1)

- 1 In the **Model Builder** window, under **Component 1 (comp1) > Geometry 1** right-click **Work Plane 1 (wp1)** and choose **Extrude**.
- 2 In the **Settings** window for **Extrude**, locate the **Distances** section.
- 3 In the table, enter the following settings:

Distances (μm)
12

Form Union (fin)

- 1 In the **Model Builder** window, click **Form Union (fin)**.
- 2 In the **Settings** window for **Form Union/Assembly**, click  **Build Selected**.

Geometry

- 1 In the **Geometry** toolbar, click  **Selections** and choose **Explicit Selection**.
- 2 In the **Settings** window for **Explicit Selection**, type Geometry in the **Label** text field.
- 3 Locate the **Entities to Select** section. From the **Geometric entity level** list, choose **Object**.
- 4 Select the object **fin** only.

Ground Plane

- 1 In the **Geometry** toolbar, click  **Selections** and choose **Box Selection**.
- 2 In the **Settings** window for **Box Selection**, type Ground Plane in the **Label** text field.
- 3 Locate the **Geometric Entity Level** section. From the **Level** list, choose **Boundary**.

- 4 Locate the **Box Limits** section. In the **z minimum** text field, type -2.
- 5 In the **z maximum** text field, type -1.
- 6 Locate the **Output Entities** section. From the **Include entity if** list, choose **Entity inside box**.

Oxide

- 1 In the **Geometry** toolbar, click  **Selections** and choose **Box Selection**.
- 2 In the **Settings** window for **Box Selection**, type Oxide in the **Label** text field.
- 3 Locate the **Box Limits** section. In the **z minimum** text field, type -1.
- 4 In the **z maximum** text field, type -0.9.

Nitride

- 1 In the **Geometry** toolbar, click  **Selections** and choose **Box Selection**.
- 2 In the **Settings** window for **Box Selection**, type Nitride in the **Label** text field.
- 3 Locate the **Box Limits** section. In the **z minimum** text field, type -0.4.
- 4 In the **z maximum** text field, type -0.35.

Electrode

- 1 In the **Geometry** toolbar, click  **Selections** and choose **Box Selection**.
- 2 In the **Settings** window for **Box Selection**, type Electrode in the **Label** text field.
- 3 Locate the **Box Limits** section. In the **x minimum** text field, type -0.1.
- 4 In the **x maximum** text field, type 0.1.
- 5 In the **y minimum** text field, type -4.2.
- 6 In the **z minimum** text field, type -0.15.
- 7 In the **z maximum** text field, type -0.1.

Ball Selection 1 (ballsel1)

- 1 In the **Geometry** toolbar, click  **Selections** and choose **Ball Selection**.
- 2 In the **Settings** window for **Ball Selection**, locate the **Ball Center** section.
- 3 In the **z** text field, type 1.
- 4 Locate the **Ball Radius** section. In the **Radius** text field, type 0.1.

Box Selection 5 (boxsel5)

- 1 In the **Geometry** toolbar, click  **Selections** and choose **Box Selection**.
- 2 In the **Settings** window for **Box Selection**, locate the **Box Limits** section.
- 3 In the **y maximum** text field, type 4.8.

- 4 In the **z minimum** text field, type -0.35.
- 5 In the **z maximum** text field, type 0.05.
- 6 Locate the **Output Entities** section. From the **Include entity if** list, choose **Entity inside box**.

Box Selection 6 (boxsel6)

- 1 In the **Geometry** toolbar, click  **Selections** and choose **Box Selection**.
- 2 In the **Settings** window for **Box Selection**, locate the **Box Limits** section.
- 3 In the **x minimum** text field, type -15.
- 4 In the **x maximum** text field, type 15.
- 5 In the **y maximum** text field, type 4.8.
- 6 In the **z minimum** text field, type -0.35.
- 7 In the **z maximum** text field, type 0.05.
- 8 Locate the **Output Entities** section. From the **Include entity if** list, choose **Entity inside box**.

Resonator

- 1 In the **Geometry** toolbar, click  **Selections** and choose **Difference Selection**.
- 2 In the **Settings** window for **Difference Selection**, locate the **Input Entities** section.
- 3 Click the **+ Add** button for **Selections to add**.
- 4 In the **Add** dialog, in the **Selections to add** list, choose **Ball Selection 1** and **Box Selection 5**.
- 5 Click **OK**.
- 6 In the **Settings** window for **Difference Selection**, locate the **Input Entities** section.
- 7 Click the **+ Add** button for **Selections to subtract**.
- 8 In the **Add** dialog, select **Box Selection 6** in the **Selections to subtract** list.
- 9 Click **OK**.
- 10 In the **Settings** window for **Difference Selection**, type Resonator in the **Label** text field.

PolySi

- 1 In the **Geometry** toolbar, click  **Selections** and choose **Union Selection**.
- 2 In the **Settings** window for **Union Selection**, locate the **Input Entities** section.
- 3 Click **+ Add**.
- 4 In the **Add** dialog, in the **Selections to add** list, choose **Electrode** and **Resonator**.
- 5 Click **OK**.

6 In the **Settings** window for **Union Selection**, type PolySi in the **Label** text field.

Air

- 1 In the **Geometry** toolbar, click  **Selections** and choose **Difference Selection**.
- 2 In the **Settings** window for **Difference Selection**, type Air in the **Label** text field.
- 3 Locate the **Input Entities** section. Click the **+ Add** button for **Selections to add**.
- 4 In the **Add** dialog, select **Geometry** in the **Selections to add** list.
- 5 Click **OK**.
- 6 In the **Settings** window for **Difference Selection**, locate the **Input Entities** section.
- 7 Click the **+ Add** button for **Selections to subtract**.
- 8 In the **Add** dialog, in the **Selections to subtract** list, choose **Oxide**, **Nitride**, and **PolySi**.
- 9 Click **OK**.

Resonator Boundaries

- 1 In the **Geometry** toolbar, click  **Selections** and choose **Adjacent Selection**.
- 2 In the **Settings** window for **Adjacent Selection**, type Resonator Boundaries in the **Label** text field.
- 3 Locate the **Input Entities** section. Click **+ Add**.
- 4 In the **Add** dialog, select **Resonator** in the **Input selections** list.
- 5 Click **OK**.

Electrode Boundaries

- 1 In the **Geometry** toolbar, click  **Selections** and choose **Adjacent Selection**.
- 2 In the **Settings** window for **Adjacent Selection**, type Electrode Boundaries in the **Label** text field.
- 3 Locate the **Input Entities** section. Click **+ Add**.
- 4 In the **Add** dialog, select **Electrode** in the **Input selections** list.
- 5 Click **OK**.

Nitride Boundaries

- 1 In the **Geometry** toolbar, click  **Selections** and choose **Adjacent Selection**.
- 2 In the **Settings** window for **Adjacent Selection**, type Nitride Boundaries in the **Label** text field.
- 3 Locate the **Input Entities** section. Click **+ Add**.
- 4 In the **Add** dialog, select **Nitride** in the **Input selections** list.
- 5 Click **OK**.

Geometry Exterior Boundaries

- 1 In the **Geometry** toolbar, click  **Selections** and choose **Adjacent Selection**.
- 2 In the **Settings** window for **Adjacent Selection**, locate the **Input Entities** section.
- 3 Click **+ Add**.
- 4 In the **Add** dialog, select **Geometry** in the **Input selections** list.
- 5 Click **OK**.
- 6 In the **Settings** window for **Adjacent Selection**, type *Geometry Exterior Boundaries* in the **Label** text field.



Resonator Exterior Boundaries

- 1 In the **Geometry** toolbar, click  **Selections** and choose **Difference Selection**.
- 2 In the **Settings** window for **Difference Selection**, locate the **Geometric Entity Level** section.
- 3 From the **Level** list, choose **Boundary**.
- 4 In the **Label** text field, type *Resonator Exterior Boundaries*.
- 5 Locate the **Input Entities** section. Click the **+ Add** button for **Selections to add**.
- 6 In the **Add** dialog, select **Resonator Boundaries** in the **Selections to add** list.
- 7 Click **OK**.
- 8 In the **Settings** window for **Difference Selection**, locate the **Input Entities** section.
- 9 Click the **+ Add** button for **Selections to subtract**.
- 10 In the **Add** dialog, select **Geometry Exterior Boundaries** in the **Selections to subtract** list.
- 11 Click **OK**.

Electrode Exterior Boundaries

- 1 In the **Geometry** toolbar, click  **Selections** and choose **Difference Selection**.
- 2 In the **Settings** window for **Difference Selection**, type *Electrode Exterior Boundaries* in the **Label** text field.
- 3 Locate the **Geometric Entity Level** section. From the **Level** list, choose **Boundary**.
- 4 Locate the **Input Entities** section. Click the **+ Add** button for **Selections to add**.
- 5 In the **Add** dialog, select **Electrode Boundaries** in the **Selections to add** list.
- 6 Click **OK**.
- 7 In the **Settings** window for **Difference Selection**, locate the **Input Entities** section.
- 8 Click the **+ Add** button for **Selections to subtract**.
- 9 In the **Add** dialog, select **Geometry Exterior Boundaries** in the **Selections to subtract** list.
- 10 Click **OK**.

Fixed Boundaries

- 1 In the **Geometry** toolbar, click  **Selections** and choose **Intersection Selection**.
- 2 In the **Settings** window for **Intersection Selection**, type **Fixed Boundaries** in the **Label** text field.
- 3 Locate the **Geometric Entity Level** section. From the **Level** list, choose **Boundary**.
- 4 Locate the **Input Entities** section. Click  **Add**.
- 5 In the **Add** dialog, in the **Selections to intersect** list, choose **Nitride Boundaries** and **Resonator Exterior Boundaries**.
- 6 Click **OK**.

Symmetry Boundaries

- 1 In the **Geometry** toolbar, click  **Selections** and choose **Box Selection**.
- 2 In the **Settings** window for **Box Selection**, type **Symmetry Boundaries** in the **Label** text field.
- 3 Locate the **Geometric Entity Level** section. From the **Level** list, choose **Boundary**.
- 4 Locate the **Box Limits** section. In the **x minimum** text field, type **-0.1**.
- 5 In the **x maximum** text field, type **0.1**.
- 6 Locate the **Output Entities** section. From the **Include entity if** list, choose **Entity inside box**.

Free Triangular Mesh

- 1 In the **Geometry** toolbar, click  **Selections** and choose **Explicit Selection**.
- 2 In the **Settings** window for **Explicit Selection**, locate the **Entities to Select** section.
- 3 From the **Geometric entity level** list, choose **Boundary**.
- 4 Select the **Group by continuous tangent** checkbox.
- 5 In the **Label** text field, type **Free Triangular Mesh**.
- 6 On the object **fin**, select Boundaries 2, 5, 8, 55, 58, 112, 163, and 254 only.