



Model created in COMSOL Multiphysics 6.4

# Truck Mounted Crane

## *Introduction*

---

Many trucks are equipped with cranes for load handling. Such cranes have a number of hydraulic cylinders controlling the motion, and several mechanisms.

In this example, a rigid-body analysis of such a crane is performed in order to find cylinder forces and axle forces during an operating cycle.

## *Model Definition*

---

The crane geometry, which is imported from a CAD model, is shown in [Figure 1](#) and [Figure 2](#). In all, it consists of 14 parts that can move relative to each other.

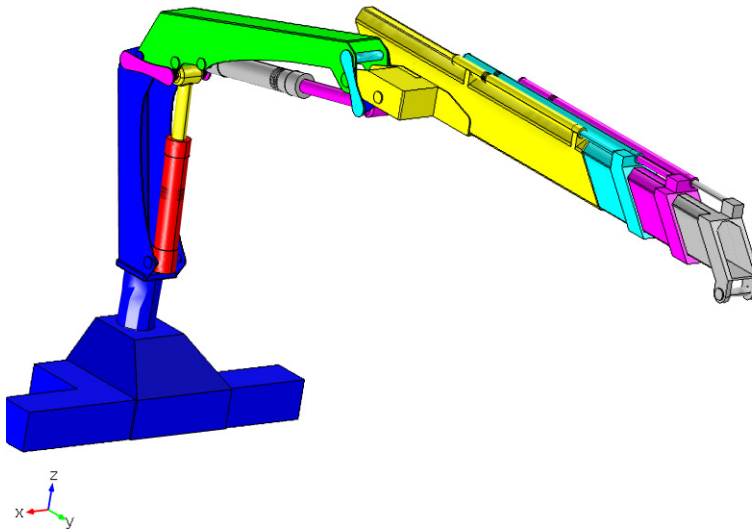

*Figure 1: Crane geometry.*

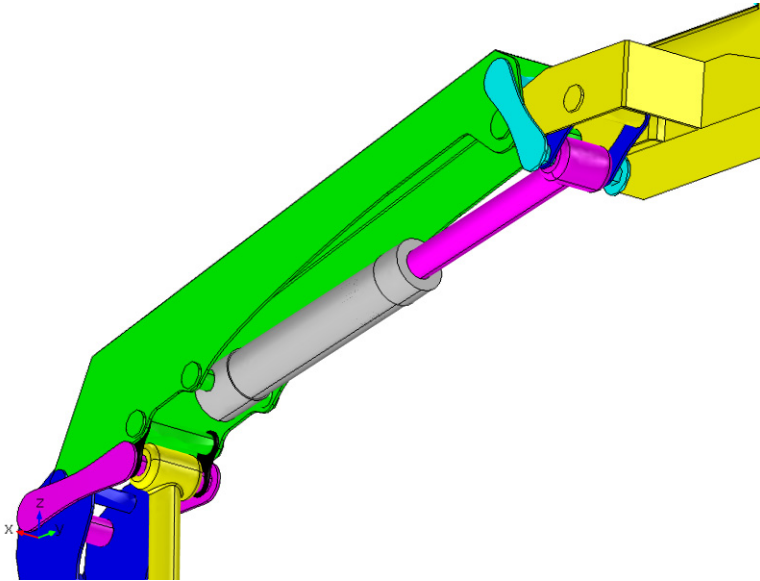

Figure 2: Close-up of link mechanisms.

TABLE 1: IDENTIFICATION OF THE CRANE PARTS

PART	NAME IN MODEL	COLOR IN FIGURE
Base	Base	Blue
Inner boom	Boom1	Green
Outer Boom	Boom2	Yellow
Telescopic extensions	Extension1, Extension2, Extension3	Cyan, Magenta, Gray
Boom lift cylinders	Cylinder1, Cylinder2	Red, Gray
Boom lift pistons	Piston1, Piston2	Yellow, Magenta
Inner link mechanism	Link1, Link2	Magenta, Black
Outer link mechanism	Link3, Link4	Cyan, Blue

### LOADS

- Self-weight in the negative  $Z$  direction
- A payload of 1000 kg at the tip of the crane

### OPERATING CYCLE

The simulated working cycle consists of lifting the payload from a position far away and below the crane. The crane first moves the load upward and then inward to a position close

to the crane. The trajectory of the crane tip during the operating cycle is shown in [Figure 3](#).

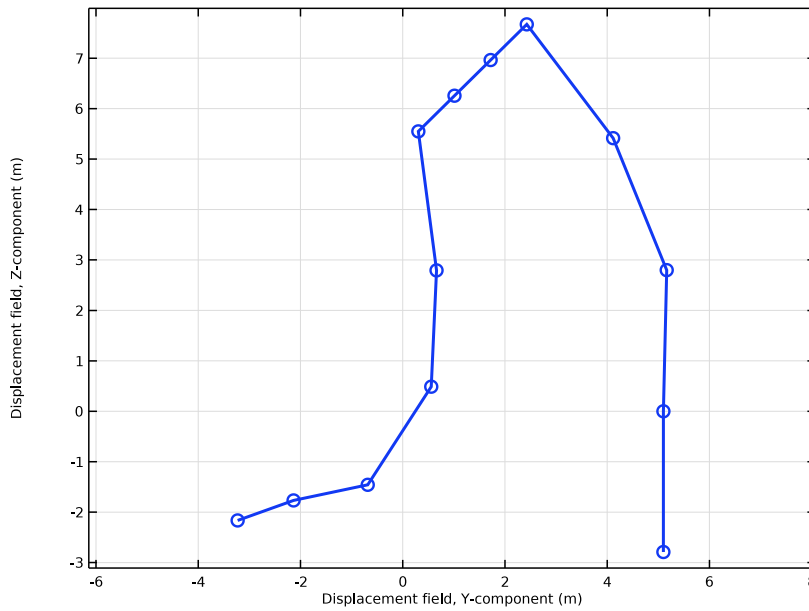

*Figure 3: The trajectory of the crane tip during the operating cycle.*

In real life, the crane is operated by controlling three cylinder lengths:

- The inner cylinder, which raises the inner boom.
- The outer cylinder, which controls the angle between the inner boom and the outer boom.
- The extension cylinders, which control how far out the extensions are. The three cylinders are synchronized so that all of them have the same extension.

To prescribe an operating cycle, it is more convenient to use the angles of the booms as parameters instead of cylinder lengths. The parameters chosen to define the operating cycle are given in [Table 2](#).

TABLE 2: OPERATING CYCLE.

Position	Inner boom angle to horizontal (degrees)	Angle between inner and outer boom (degrees)	Total extension (m)
1	-15	0	5.5
2	0	0	5.1

TABLE 2: OPERATING CYCLE.

Position	Inner boom angle to horizontal (degrees)	Angle between inner and outer boom (degrees)	Total extension (m)
3	15	0	5.5
4	30	0	5.5
5	45	0	5.5
6	45	0	4.5
7	45	0	3.5
8	45	0	2.5
9	45	-30	1.5
10	45	-60	1.5
11	45	-90	1.5
12	60	-120	1.5
13	60	-135	1.5

### Results and Discussion

The crane in the 9<sup>th</sup> position of the operating cycle is shown in [Figure 4](#).

Angle1=45 rad, RelAng=-30 rad, ExtLen=1.5 m Displacement magnitude (m)

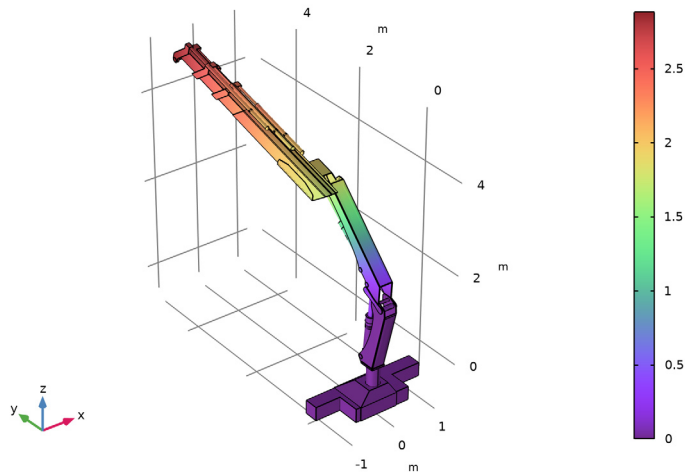
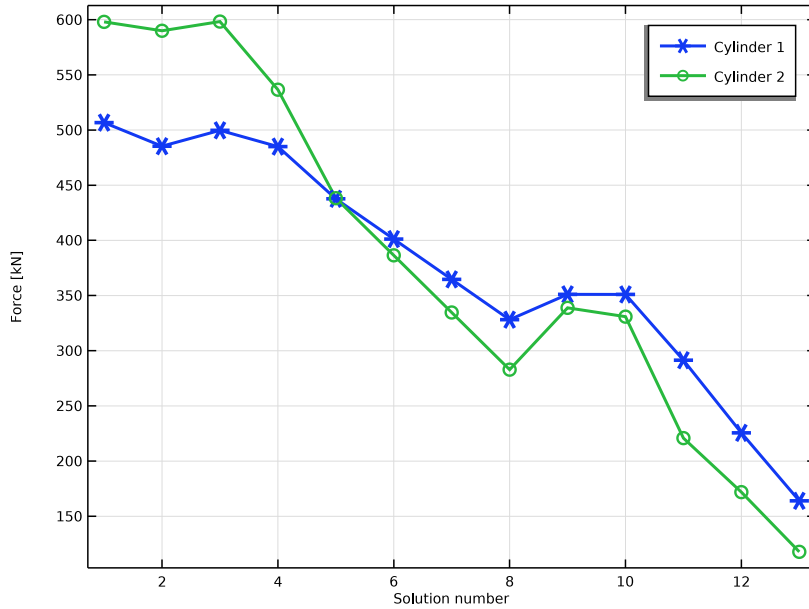

Figure 4: Crane position 9.

The forces in the cylinders controlling the boom are shown in [Figure 5](#). Compressive forces are positive. As can be anticipated, the cylinder forces are large when the payload is far from the crane base, causing large moments around the hinges.



*Figure 5: Variation of forces in boom lifting cylinders during the operating cycle.*

The forces in the extension cylinders are shown in [Figure 6](#), with a compressive force being defined as positive. When the outer boom is horizontal (position 2), no axial force is needed to maintain the position. The force is higher in the inner cylinders, since they also have to carry the weight of extension segments further out.

The forces acting on the hinge axle connecting the inner and outer booms are shown in [Figure 7](#). In a similar way you can plot the forces acting in the connections between any parts for the crane. These results supply essential information for the structural design of such details.

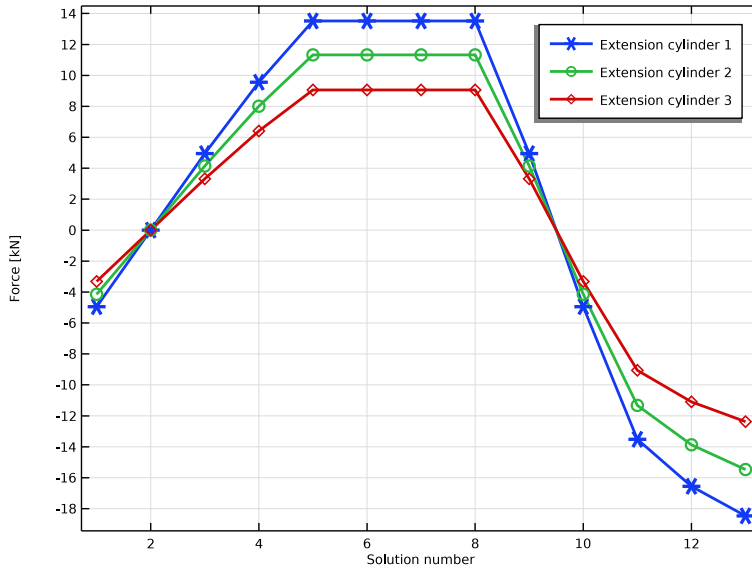

Figure 6: Variation of forces in extension cylinders over the operating cycle.

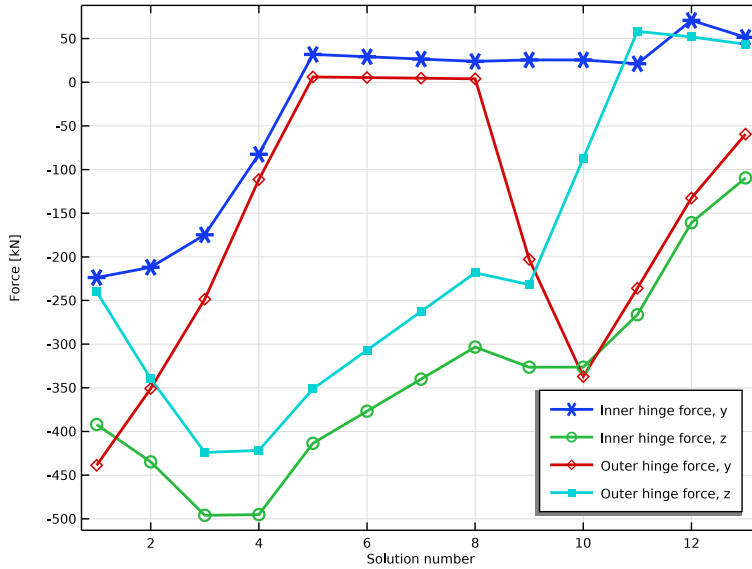

Figure 7: Forces on the hinges between the main crane parts.

## *Notes About the COMSOL Implementation*

---

The analysis consists of a series of stationary solutions, controlled by a sweep over the 13 parameter combinations. The parameters used are the boom angles and the total displacement of the extension cylinders.

For the boom cylinders, it is the extension of the cylinders which you can enter as input. The known parameters are the boom angles. In this model, you add extra Global Equations where the cylinder extensions are computed based on the required boom angles.

In a model like this, where there are many parts connected to each other, great care must be taken in the selection of joint types to avoid overconstraining the problem. As an example, if only Hinge joints are chosen for one of the link mechanisms, then the translation out of the plane of the crane is prescribed in closed loop. Checking the **Rigid Body DOF Summary** table gives useful information that helps to avoid such problems. Another possibility is to add some flexibility in the joints in overconstrained directions. This relieves the overconstraint problem.

---

**Application Library path:** Multibody\_Dynamics\_Module/  
Machinery\_and\_Robotics/truck\_mounted\_crane

---

## *Modeling Instructions*



---

From the **File** menu, choose **New**.

### **NEW**



In the **New** window, click  **Model Wizard**.

### **MODEL WIZARD**

- 1 In the **Model Wizard** window, click  **3D**.
- 2 In the **Select Physics** tree, select **Structural Mechanics > Multibody Dynamics (mbd)**.
- 3 Click **Add**.
- 4 Click  **Study**.
- 5 In the **Select Study** tree, select **General Studies > Stationary**.
- 6 Click  **Done**.

## GEOMETRY I



### *Import I (impI)*

- 1 In the **Geometry** toolbar, click  **Import**.
- 2 In the **Settings** window for **Import**, locate the **Source** section.
- 3 Click  **Browse**.
- 4 Browse to the model's Application Libraries folder and double-click the file `truck_mounted_crane.mphbin`.
- 5 Click  **Import**.

### *Form Union (fin)*

- 1 In the **Model Builder** window, under **Component 1 (comp1) > Geometry 1** click **Form Union (fin)**.
- 2 In the **Settings** window for **Form Union/Assembly**, locate the **Form Union/Assembly** section.
- 3 From the **Action** list, choose **Form an assembly**.
- 4 Clear the **Create pairs** checkbox.
- 5 In the **Geometry** toolbar, click  **Build All**.  
Disable the analysis of the geometry as the remaining small geometric details can be kept.
- 6 In the **Model Builder** window, click **Geometry 1**.
- 7 In the **Settings** window for **Geometry**, locate the **Cleanup** section.
- 8 Clear the **Automatic detection of small details** checkbox.

## ADD MATERIAL

- 1 In the **Materials** toolbar, click  **Add Material** to open the **Add Material** window.
- 2 Go to the **Add Material** window.
- 3 In the tree, select **Built-in > Structural steel**.
- 4 Click the **Add to Component** button in the window toolbar.
- 5 In the **Materials** toolbar, click  **Add Material** to close the **Add Material** window.

## MULTIBODY DYNAMICS (MBD)

### *Base*

- 1 In the **Physics** toolbar, click  **Domains** and choose **Rigid Material**.
- 2 In the **Settings** window for **Rigid Material**, type `Base` in the **Label** text field.
- 3 Select Domains 1, 10, 17, 22, and 23 only.

### Data for Rigid Materials

1 Repeat the same operations thirteen times, entering the following data:

Label	Domain selection
Boom1	19-21
Boom2	2, 4, 13
Extension1	5, 11, 14
Extension2	6, 8, 12
Extension3	3, 7, 9
Cylinder1	29
Piston1	27
Cylinder2	30
Piston2	28
Link1	15
Link2	18, 25, 32
Link3	16
Link4	24, 26, 31

The base is kept fixed.

2 In the **Model Builder** window, under **Component 1 (comp1) > Multibody Dynamics (mbd)** click **Base**.

#### Fixed Constraint 1

In the **Physics** toolbar, click  **Attributes** and choose **Fixed Constraint**.

Now define the connections between various parts of the crane.

#### Hinge Base-Boom1

1 In the **Physics** toolbar, click  **Global** and choose **Hinge Joint**.

2 In the **Settings** window for **Hinge Joint**, type Hinge Base-Boom1 in the **Label** text field.

3 Locate the **Attachment Selection** section. From the **Source** list, choose **Base**.

4 From the **Destination** list, choose **Boom1**.

5 Locate the **Joint Forces and Moments** section. From the list, choose **Computed using weak constraints**.

#### Center of Joint: Boundary 1

1 In the **Model Builder** window, click **Center of Joint: Boundary 1**.

2 Select Boundaries 404 and 413 only.

#### *Hinge Base-Cylinder1*

- 1 In the **Physics** toolbar, click  **Global** and choose **Hinge Joint**.
- 2 In the **Settings** window for **Hinge Joint**, type Hinge Base-Cylinder1 in the **Label** text field.
- 3 Locate the **Attachment Selection** section. From the **Source** list, choose **Base**.
- 4 From the **Destination** list, choose **Cylinder1**.
- 5 Locate the **Joint Forces and Moments** section. From the list, choose **Computed using weak constraints**.

#### *Center of Joint: Boundary 1*

- 1 In the **Model Builder** window, click **Center of Joint: Boundary 1**.
- 2 Select Boundaries 589 and 598 only.

#### *Hinge Base-Link1*

- 1 In the **Physics** toolbar, click  **Global** and choose **Hinge Joint**.
- 2 In the **Settings** window for **Hinge Joint**, type Hinge Base-Link1 in the **Label** text field.
- 3 Locate the **Attachment Selection** section. From the **Source** list, choose **Base**.
- 4 From the **Destination** list, choose **Link1**.
- 5 Locate the **Joint Forces and Moments** section. From the list, choose **Computed using weak constraints**.

#### *Center of Joint: Boundary 1*

- 1 In the **Model Builder** window, click **Center of Joint: Boundary 1**.
- 2 Select Boundaries 365 and 366 only.

#### *Hinge Boom1-Link2*

- 1 In the **Physics** toolbar, click  **Global** and choose **Hinge Joint**.
- 2 In the **Settings** window for **Hinge Joint**, type Hinge Boom1-Link2 in the **Label** text field.
- 3 Locate the **Attachment Selection** section. From the **Source** list, choose **Boom1**.
- 4 From the **Destination** list, choose **Link2**.
- 5 Locate the **Joint Forces and Moments** section. From the list, choose **Computed using weak constraints**.

#### *Center of Joint: Boundary 1*

- 1 In the **Model Builder** window, click **Center of Joint: Boundary 1**.
- 2 Select Boundaries 414 and 423 only.

#### *Slot Link 1-Link2*

- 1 In the **Physics** toolbar, click  **Global** and choose **Slot Joint**.
- 2 In the **Settings** window for **Slot Joint**, type Slot Link1-Link2 in the **Label** text field.
- 3 Locate the **Attachment Selection** section. From the **Source** list, choose **Link1**.
- 4 From the **Destination** list, choose **Link2**.
- 5 Locate the **Joint Forces and Moments** section. From the list, choose **Computed using weak constraints**.

#### *Center of Joint: Boundary 1*

- 1 In the **Model Builder** window, click **Center of Joint: Boundary 1**.
- 2 Select Boundaries 362 and 363 only.

#### *Slot Link 1-Piston 1*

- 1 In the **Model Builder** window, right-click **Slot Link1-Link2** and choose **Duplicate**.
- 2 In the **Settings** window for **Slot Joint**, type Slot Link1-Piston1 in the **Label** text field.
- 3 Locate the **Attachment Selection** section. From the **Destination** list, choose **Piston1**.

#### *Prismatic Cylinder 1-Piston 1*

- 1 In the **Physics** toolbar, click  **Global** and choose **Prismatic Joint**.
- 2 In the **Settings** window for **Prismatic Joint**, type Prismatic Cylinder1-Piston1 in the **Label** text field.
- 3 Locate the **Attachment Selection** section. From the **Source** list, choose **Cylinder1**.
- 4 From the **Destination** list, choose **Piston1**.
- 5 Locate the **Axis of Joint** section. From the list, choose **Select a parallel edge**.
- 6 Select the **Reverse direction** checkbox.
- 7 Locate the **Joint Forces and Moments** section. From the list, choose **Computed using weak constraints**.

#### *Center of Joint: Boundary 1*

- 1 In the **Model Builder** window, click **Center of Joint: Boundary 1**.
- 2 Select Boundary 710 only.

#### *Joint Axis 1*

- 1 In the **Model Builder** window, click **Joint Axis 1**.
- 2 Select Edge 1564 only.

*Hinge Base-Boom1, Hinge Base-Cylinder1, Hinge Base-Link1, Hinge Boom1-Link2, Prismatic Cylinder1-Piston1, Slot Link1-Link2, Slot Link1-Piston1*

- 1 In the **Model Builder** window, under **Component 1 (comp1) > Multibody Dynamics (mbd)**, Ctrl-click to select **Hinge Base-Boom1, Hinge Base-Cylinder1, Hinge Base-Link1, Hinge Boom1-Link2, Slot Link1-Link2, Slot Link1-Piston1**, and **Prismatic Cylinder1-Piston1**.
- 2 Right-click and choose **Duplicate**.

*Hinge Boom1-Boom2*

- 1 In the **Settings** window for **Hinge Joint**, type Hinge Boom1-Boom2 in the **Label** text field.
- 2 Locate the **Attachment Selection** section. From the **Source** list, choose **Boom1**.
- 3 From the **Destination** list, choose **Boom2**.

*Center of Joint: Boundary 1*

- 1 In the **Model Builder** window, expand the **Hinge Boom1-Boom2** node, then click **Center of Joint: Boundary 1**.
- 2 In the **Settings** window for **Center of Joint: Boundary**, locate the **Boundary Selection** section.
- 3 Click  **Clear Selection**.
- 4 Select Boundaries 438 and 439 only.

*Hinge Boom1-Cylinder2*

- 1 In the **Model Builder** window, under **Component 1 (comp1) > Multibody Dynamics (mbd)** click **Hinge Base-Cylinder1.1**.
- 2 In the **Settings** window for **Hinge Joint**, type Hinge Boom1-Cylinder2 in the **Label** text field.
- 3 Locate the **Attachment Selection** section. From the **Source** list, choose **Boom1**.
- 4 From the **Destination** list, choose **Cylinder2**.

*Center of Joint: Boundary 1*

- 1 In the **Model Builder** window, expand the **Hinge Boom1-Cylinder2** node, then click **Center of Joint: Boundary 1**.
- 2 In the **Settings** window for **Center of Joint: Boundary**, locate the **Boundary Selection** section.
- 3 Click  **Clear Selection**.
- 4 Select Boundaries 424 and 433 only.

#### *Hinge Boom1-Link3*

- 1 In the **Model Builder** window, under **Component 1 (comp1) > Multibody Dynamics (mbd)** click **Hinge Base-Link1.1**.
- 2 In the **Settings** window for **Hinge Joint**, type Hinge Boom1-Link3 in the **Label** text field.
- 3 Locate the **Attachment Selection** section. From the **Source** list, choose **Boom1**.
- 4 From the **Destination** list, choose **Link3**.

#### *Center of Joint: Boundary 1*

- 1 In the **Model Builder** window, expand the **Hinge Boom1-Link3** node, then click **Center of Joint: Boundary 1**.
- 2 In the **Settings** window for **Center of Joint: Boundary**, locate the **Boundary Selection** section.
- 3 Click  **Clear Selection**.
- 4 Select Boundaries 391 and 392 only.

#### *Hinge Boom2-Link4*

- 1 In the **Model Builder** window, under **Component 1 (comp1) > Multibody Dynamics (mbd)** click **Hinge Boom1-Link2.1**.
- 2 In the **Settings** window for **Hinge Joint**, type Hinge Boom2-Link4 in the **Label** text field.
- 3 Locate the **Attachment Selection** section. From the **Source** list, choose **Boom2**.
- 4 From the **Destination** list, choose **Link4**.

#### *Center of Joint: Boundary 1*

- 1 In the **Model Builder** window, expand the **Hinge Boom2-Link4** node, then click **Center of Joint: Boundary 1**.
- 2 In the **Settings** window for **Center of Joint: Boundary**, locate the **Boundary Selection** section.
- 3 Click  **Clear Selection**.
- 4 Select Boundaries 603 and 604 only.

#### *Slot Link3-Link4*

- 1 In the **Model Builder** window, under **Component 1 (comp1) > Multibody Dynamics (mbd)** click **Slot Link1-Link2.1**.
- 2 In the **Settings** window for **Slot Joint**, type Slot Link3-Link4 in the **Label** text field.
- 3 Locate the **Attachment Selection** section. From the **Source** list, choose **Link3**.
- 4 From the **Destination** list, choose **Link4**.

*Center of Joint: Boundary 1*

- 1 In the **Model Builder** window, expand the **Slot Link3-Link4** node, then click **Center of Joint: Boundary 1**.
- 2 In the **Settings** window for **Center of Joint: Boundary**, locate the **Boundary Selection** section.
- 3 Click  **Clear Selection**.
- 4 Select Boundaries 388 and 389 only.

*Slot Link3-Piston2*

- 1 In the **Model Builder** window, under **Component 1 (comp1) > Multibody Dynamics (mbd)** click **Slot Link1-Piston1.1**.
- 2 In the **Settings** window for **Slot Joint**, type Slot Link3-Piston2 in the **Label** text field.
- 3 Locate the **Attachment Selection** section. From the **Source** list, choose **Link3**.
- 4 From the **Destination** list, choose **Piston2**.

*Center of Joint: Boundary 1*

- 1 In the **Model Builder** window, expand the **Slot Link3-Piston2** node, then click **Center of Joint: Boundary 1**.
- 2 In the **Settings** window for **Center of Joint: Boundary**, locate the **Boundary Selection** section.
- 3 Click  **Clear Selection**.
- 4 Select Boundaries 388 and 389 only.

*Prismatic Cylinder2-Piston2*

- 1 In the **Model Builder** window, under **Component 1 (comp1) > Multibody Dynamics (mbd)** click **Prismatic Cylinder1-Piston1.1**.
- 2 In the **Settings** window for **Prismatic Joint**, type Prismatic Cylinder2-Piston2 in the **Label** text field.
- 3 Locate the **Attachment Selection** section. From the **Source** list, choose **Cylinder2**.
- 4 From the **Destination** list, choose **Piston2**.
- 5 Locate the **Axis of Joint** section. Clear the **Reverse direction** checkbox.

*Center of Joint: Boundary 1*

- 1 In the **Model Builder** window, expand the **Prismatic Cylinder2-Piston2** node, then click **Center of Joint: Boundary 1**.
- 2 In the **Settings** window for **Center of Joint: Boundary**, locate the **Boundary Selection** section.

- 3 Click  **Clear Selection**.
- 4 Select Boundary 746 only.

*Joint Axis 1*

- 1 In the **Model Builder** window, click **Joint Axis 1**.
- 2 In the **Settings** window for **Joint Axis**, locate the **Edge Selection** section.
- 3 Click  **Clear Selection**.
- 4 Select Edge 1682 only.

*Prismatic Boom2-Extension 1*

- 1 In the **Physics** toolbar, click  **Global** and choose **Prismatic Joint**.
- 2 In the **Settings** window for **Prismatic Joint**, type Prismatic Boom2-Extension1 in the **Label** text field.
- 3 Locate the **Attachment Selection** section. From the **Source** list, choose **Boom2**.
- 4 From the **Destination** list, choose **Extension 1**.
- 5 Locate the **Axis of Joint** section. Specify the  $\mathbf{e}_0$  vector as

0	x
1	y
0	z

- 6 Locate the **Joint Forces and Moments** section. From the list, choose **Computed using weak constraints**.

*Center of Joint: Boundary 1*

- 1 In the **Model Builder** window, click **Center of Joint: Boundary 1**.
- 2 Select Boundaries 315 and 316 only.

*Prismatic Extension 1-Extension 2*

- 1 In the **Physics** toolbar, click  **Global** and choose **Prismatic Joint**.
- 2 In the **Settings** window for **Prismatic Joint**, type Prismatic Extension1-Extension2 in the **Label** text field.
- 3 Locate the **Attachment Selection** section. From the **Source** list, choose **Extension 1**.
- 4 From the **Destination** list, choose **Extension 2**.

5 Locate the **Axis of Joint** section. Specify the  $e_0$  vector as

0	x
1	y
0	z

6 Locate the **Joint Forces and Moments** section. From the list, choose **Computed using weak constraints**.

*Center of Joint: Boundary 1*

1 In the **Model Builder** window, click **Center of Joint: Boundary 1**.

2 Select Boundaries 280 and 284 only.

*Prismatic Extension2-Extension3*

1 In the **Physics** toolbar, click  **Global** and choose **Prismatic Joint**.

2 In the **Settings** window for **Prismatic Joint**, type Prismatic Extension2-Extension3 in the **Label** text field.

3 Locate the **Attachment Selection** section. From the **Source** list, choose **Extension2**.

4 From the **Destination** list, choose **Extension3**.

5 Locate the **Axis of Joint** section. Specify the  $e_0$  vector as

0	x
1	y
0	z

6 Locate the **Joint Forces and Moments** section. From the list, choose **Computed using weak constraints**.

*Center of Joint: Boundary 1*

1 In the **Model Builder** window, click **Center of Joint: Boundary 1**.

2 Select Boundaries 223 and 224 only.

Check that there are now five remaining degrees of freedom, one for each cylinder.

3 In the **Model Builder** window, click **Multibody Dynamics (mbd)**.

4 In the **Settings** window for **Multibody Dynamics**, click to expand the **Rigid Body DOF Summary** section.

*Gravity 1*

In the **Physics** toolbar, click  **Global** and choose **Gravity**.

### Body Load I

- 1 In the **Physics** toolbar, click  **Domains** and choose **Body Load**.
- 2 Select Domain 3 only.
- 3 In the **Settings** window for **Body Load**, locate the **Force** section.
- 4 From the **Load type** list, choose **Total force**.
- 5 Specify the  $\mathbf{F}_{tot}$  vector as

0	x
0	y
-1000[kg]*g_const	z

Now, prescribe the position of all cylinders. The operation of three extension cylinders is synchronized.

## GLOBAL DEFINITIONS

### Parameters I

- 1 In the **Model Builder** window, under **Global Definitions** click **Parameters I**.
- 2 In the **Settings** window for **Parameters**, locate the **Parameters** section.
- 3 In the table, enter the following settings:

Name	Expression	Value	Description
Angle1	0[deg]	0 rad	Angle to horizontal, inner boom
RelAng	0[deg]	0 rad	Angle between booms
ExtLen	0[m]	0 m	Total extension length

## MULTIBODY DYNAMICS (MBD)

- 1 Click the  **Show More Options** button in the **Model Builder** toolbar.
- 2 In the **Show More Options** dialog, in the tree, select the checkbox for the node **Physics > Equation Contributions**.
- 3 Click **OK**.

### Global Equations I (ODEI)

- 1 In the **Physics** toolbar, click  **Global** and choose **Global Equations**.
- 2 In the **Settings** window for **Global Equations**, locate the **Global Equations** section.

3 In the table, enter the following settings:

Name	$f(u,ut,utt,t)$ (l)	Initial value (u_0) (l)	Initial value (ut_0) (l/s)	Description
cyl1Pos	Angle1-mbd.hgj1.th* 180/pi	0	0	Inner cylinder extension

4 Locate the **Units** section. Click  **Select Dependent Variable Quantity**.

5 In the **Physical Quantity** dialog, type displacement in the text field.

6 In the tree, select **General > Displacement (m)**.

7 Click **OK**.

8 In the **Settings** window for **Global Equations**, locate the **Global Equations** section.

9 In the table, enter the following settings:

Name	$f(u,ut,utt,t)$ (l)	Initial value (u_0) (m)	Initial value (ut_0) (m/s)	Description
cyl2Pos	RelAng-mbd.hgj5.th* 180/pi	0	0	Outer cylinder extension

#### *Prismatic Cylinder1-Piston1*

In the **Model Builder** window, click **Prismatic Cylinder1-Piston1**.

#### *Prescribed Motion 1*

1 In the **Physics** toolbar, click  **Attributes** and choose **Prescribed Motion**.

2 In the **Settings** window for **Prescribed Motion**, locate the **Prescribed Translational Motion** section.

3 In the  $u_p$  text field, type cyl1Pos.

The prescribed displacements for the boom cylinders are given by the global equations. They must not couple back into the equation system through reaction forces.

4 Click to expand the **Reaction Force Settings** section. Select the **Apply reaction only on joint variables** checkbox.

#### *Prismatic Cylinder2-Piston2*

In the **Model Builder** window, under **Component 1 (comp1) > Multibody Dynamics (mbd)** click **Prismatic Cylinder2-Piston2**.

#### *Prescribed Motion 1*

1 In the **Physics** toolbar, click  **Attributes** and choose **Prescribed Motion**.

- 2 In the **Settings** window for **Prescribed Motion**, locate the **Prescribed Translational Motion** section.
- 3 In the  $u_p$  text field, type `cy12Pos`.
- 4 Locate the **Reaction Force Settings** section. Select the **Apply reaction only on joint variables** checkbox.

#### *Prismatic Boom2-Extension1*

In the **Model Builder** window, under **Component 1 (comp1) > Multibody Dynamics (mbd)** click **Prismatic Boom2-Extension1**.

#### *Prescribed Motion 1*

- 1 In the **Physics** toolbar, click  **Attributes** and choose **Prescribed Motion**.
- 2 In the **Settings** window for **Prescribed Motion**, locate the **Prescribed Translational Motion** section.
- 3 In the  $u_p$  text field, type `ExtLen/3`.

#### *Prismatic Extension1-Extension2*

In the **Model Builder** window, under **Component 1 (comp1) > Multibody Dynamics (mbd)** click **Prismatic Extension1-Extension2**.

#### *Prescribed Motion 1*

- 1 In the **Physics** toolbar, click  **Attributes** and choose **Prescribed Motion**.
- 2 In the **Settings** window for **Prescribed Motion**, locate the **Prescribed Translational Motion** section.
- 3 In the  $u_p$  text field, type `ExtLen/3`.

#### *Prismatic Extension2-Extension3*

In the **Model Builder** window, under **Component 1 (comp1) > Multibody Dynamics (mbd)** click **Prismatic Extension2-Extension3**.

#### *Prescribed Motion 1*

- 1 In the **Physics** toolbar, click  **Attributes** and choose **Prescribed Motion**.
- 2 In the **Settings** window for **Prescribed Motion**, locate the **Prescribed Translational Motion** section.
- 3 In the  $u_p$  text field, type `ExtLen/3`.

*Base, Boom1, Boom2, Cylinder1, Cylinder2, Extension1, Extension2, Extension3, Link1, Link2, Link3, Link4, Piston1, Piston2*

**1** In the **Model Builder** window, under **Component 1 (comp1) > Multibody Dynamics (mbd)**, Ctrl-click to select **Base, Boom1, Boom2, Extension1, Extension2, Extension3, Cylinder1, Piston1, Cylinder2, Piston2, Link1, Link2, Link3, and Link4.**

**2** Right-click and choose **Group.**

#### *Rigid Materials*

In the **Settings** window for **Group**, type Rigid Materials in the **Label** text field.

*Hinge Base-Boom1, Hinge Base-Cylinder1, Hinge Base-Link1, Hinge Boom1-Boom2, Hinge Boom1-Cylinder2, Hinge Boom1-Link2, Hinge Boom1-Link3, Hinge Boom2-Link4*

**1** In the **Model Builder** window, under **Component 1 (comp1) > Multibody Dynamics (mbd)**, Ctrl-click to select **Hinge Base-Boom1, Hinge Base-Cylinder1, Hinge Base-Link1, Hinge Boom1-Link2, Hinge Boom1-Boom2, Hinge Boom1-Cylinder2, Hinge Boom1-Link3, and Hinge Boom2-Link4.**

**2** Right-click and choose **Group.**

#### *Hinge Joints*

In the **Settings** window for **Group**, type Hinge Joints in the **Label** text field.

*Slot Link1-Link2, Slot Link1-Piston1, Slot Link3-Link4, Slot Link3-Piston2*

**1** In the **Model Builder** window, under **Component 1 (comp1) > Multibody Dynamics (mbd)**, Ctrl-click to select **Slot Link1-Link2, Slot Link1-Piston1, Slot Link3-Link4, and Slot Link3-Piston2.**

**2** Right-click and choose **Group.**

#### *Slot Joints*

In the **Settings** window for **Group**, type Slot Joints in the **Label** text field.

*Prismatic Boom2-Extension1, Prismatic Cylinder1-Piston1, Prismatic Cylinder2-Piston2, Prismatic Extension1-Extension2, Prismatic Extension2-Extension3*

**1** In the **Model Builder** window, under **Component 1 (comp1) > Multibody Dynamics (mbd)**, Ctrl-click to select **Prismatic Cylinder1-Piston1, Prismatic Cylinder2-Piston2, Prismatic Boom2-Extension1, Prismatic Extension1-Extension2, and Prismatic Extension2-Extension3.**

**2** Right-click and choose **Group.**

#### *Prismatic Joints*

In the **Settings** window for **Group**, type Prismatic Joints in the **Label** text field.

Since this is a rigid body analysis, the only requirement on the mesh is that it can resolve the geometry. Apart from that, it should be as coarse as possible in order to minimize storage and computations.

## **MESH 1**

### *Free Tetrahedral 1*

**1** In the **Model Builder** window, expand the **Component 1 (comp1) > Mesh 1** node.

**2** Right-click **Mesh 1** and choose **Free Tetrahedral**.

### *Size*

**1** In the **Settings** window for **Size**, locate the **Element Size** section.

**2** From the **Predefined** list, choose **Finer**.

### *Size 1*

**1** In the **Model Builder** window, expand the **Component 1 (comp1) > Mesh 1 > Free Tetrahedral 1** node.

**2** Right-click **Free Tetrahedral 1** and choose **Size**.

**3** In the **Settings** window for **Size**, locate the **Geometric Entity Selection** section.

**4** From the **Geometric entity level** list, choose **Domain**.

**5** Select Domains 2–4, 10, 15–24, 31, and 32 only.

### *Size 2*

**1** In the **Model Builder** window, right-click **Free Tetrahedral 1** and choose **Size**.

**2** In the **Settings** window for **Size**, locate the **Element Size** section.

**3** From the **Predefined** list, choose **Fine**.

**4** Locate the **Geometric Entity Selection** section. From the **Geometric entity level** list, choose **Domain**.

**5** Select Domains 5–7, 17–20, 23, and 24 only.

**6** In the **Model Builder** window, right-click **Mesh 1** and choose **Build All**.

## **STUDY 1**

### *Step 1: Stationary*

**1** In the **Model Builder** window, under **Study 1** click **Step 1: Stationary**.

**2** In the **Settings** window for **Stationary**, click to expand the **Study Extensions** section.

**3** Select the **Auxiliary sweep** checkbox.

The positions for the operating cycle are stored on file.

- 4 Click  **Load from File**.
- 5 Browse to the model's Application Libraries folder and double-click the file `truck_mounted_crane_solparam.txt`.
- 6 From the **Run continuation for** list, choose **No parameter**.

#### *Solution 1 (sol1)*



- 1 In the **Study** toolbar, click  **Show Default Solver**.
- 2 In the **Model Builder** window, expand the **Solution 1 (sol1)** node.
- 3 In the **Model Builder** window, expand the **Study 1 > Solver Configurations > Solution 1 (sol1) > Dependent Variables 1** node, then click **Global Equations 1 (comp1.ODE1)**.
- 4 In the **Settings** window for **State**, locate the **Scaling** section.
- 5 From the **Method** list, choose **Manual**.
- 6 In the **Scale** text field, type 0.1.

#### *Step 1: Stationary*

- 1 In the **Model Builder** window, under **Study 1** click **Step 1: Stationary**.
- 2 In the **Settings** window for **Stationary**, locate the **Study Settings** section.
- 3 From the **Tolerance** list, choose **User controlled**.
- 4 In the **Relative tolerance** text field, type 1e-6.
- 5 Click to expand the **Results While Solving** section. Select the **Plot** checkbox.
- 6 In the **Study** toolbar, click  **Compute**.

## **RESULTS**

#### *Displacement (mbd)*

- 1 In the **Settings** window for **3D Plot Group**, locate the **Data** section.
- 2 From the **Parameter value (Angle1 (rad),RelAng (rad),ExtLen (m))** list, choose **9: Angle1=45 rad, RelAng=-30 rad, ExtLen=1.5 m**.
- 3 In the **Displacement (mbd)** toolbar, click  **Plot**.
- 4 Click the  **Zoom Extents** button in the **Graphics** toolbar.

#### *Boom Cylinder Forces*

- 1 In the **Results** toolbar, click  **ID Plot Group**.
- 2 In the **Settings** window for **ID Plot Group**, type Boom Cylinder Forces in the **Label** text field.

### Global 1

- 1 Right-click **Boom Cylinder Forces** and choose **Global**.
- 2 In the **Settings** window for **Global**, locate the **y-Axis Data** section.
- 3 In the table, enter the following settings:

Expression	Unit	Description
mbd.prj1.F11	kN	Cylinder 1
mbd.prj2.F11	kN	Cylinder 2

- 4 Click to expand the **Coloring and Style** section. From the **Width** list, choose **2**.
- 5 Find the **Line markers** subsection. From the **Marker** list, choose **Cycle**.

### Boom Cylinder Forces

- 1 In the **Model Builder** window, click **Boom Cylinder Forces**.
- 2 In the **Settings** window for **ID Plot Group**, locate the **Plot Settings** section.
- 3 Select the **y-axis label** checkbox. In the associated text field, type Force [kN].
- 4 Click to expand the **Title** section. From the **Title type** list, choose **None**.
- 5 In the **Boom Cylinder Forces** toolbar, click  **Plot**.

### Extension Cylinder Forces

- 1 Right-click **Boom Cylinder Forces** and choose **Duplicate**.
- 2 In the **Model Builder** window, click **Boom Cylinder Forces 1**.
- 3 In the **Settings** window for **ID Plot Group**, type Extension Cylinder Forces in the **Label** text field.

### Global 1

- 1 In the **Model Builder** window, click **Global 1**.
- 2 In the **Settings** window for **Global**, locate the **y-Axis Data** section.
- 3 In the table, enter the following settings:

Expression	Unit	Description
mbd.prj3.F11	kN	Extension cylinder 1
mbd.prj4.F11	kN	Extension cylinder 2
mbd.prj5.F11	kN	Extension cylinder 3

- 4 In the **Extension Cylinder Forces** toolbar, click  **Plot**.

### Hinge Forces

- 1 In the **Results** toolbar, click  **ID Plot Group**.

- 2 In the **Settings** window for **ID Plot Group**, type Hinge Forces in the **Label** text field.

#### *Global 1*

- 1 Right-click **Hinge Forces** and choose **Global**.
- 2 In the **Settings** window for **Global**, locate the **y-Axis Data** section.
- 3 In the table, enter the following settings:

<b>Expression</b>	<b>Unit</b>	<b>Description</b>
mbd.hgj1.Fy	kN	Inner hinge force, y
mbd.hgj1.Fz	kN	Inner hinge force, z
mbd.hgj5.Fy	kN	Outer hinge force, y
mbd.hgj5.Fz	kN	Outer hinge force, z

- 4 Locate the **Coloring and Style** section. From the **Width** list, choose **2**.
- 5 Find the **Line markers** subsection. From the **Marker** list, choose **Cycle**.

#### *Hinge Forces*

- 1 In the **Model Builder** window, click **Hinge Forces**.
- 2 In the **Settings** window for **ID Plot Group**, locate the **Legend** section.
- 3 From the **Position** list, choose **Lower right**.
- 4 Locate the **Plot Settings** section.
- 5 Select the **y-axis label** checkbox. In the associated text field, type Force [kN].
- 6 Locate the **Title** section. From the **Title type** list, choose **None**.
- 7 In the **Hinge Forces** toolbar, click  **Plot**.

#### *Crane Tip Trajectory*

- 1 In the **Results** toolbar, click  **ID Plot Group**.
- 2 In the **Settings** window for **ID Plot Group**, type Crane Tip Trajectory in the **Label** text field.

#### *Point Graph 1*

- 1 Right-click **Crane Tip Trajectory** and choose **Point Graph**.
- 2 Select Point 350 only.
- 3 In the **Settings** window for **Point Graph**, locate the **y-Axis Data** section.
- 4 In the **Expression** text field, type w.
- 5 Locate the **x-Axis Data** section. From the **Parameter** list, choose **Expression**.
- 6 In the **Expression** text field, type v.

- 7 Click to expand the **Coloring and Style** section. From the **Width** list, choose **2**.
- 8 Find the **Line markers** subsection. From the **Marker** list, choose **Circle**.

#### *Crane Tip Trajectory*

- 1 In the **Model Builder** window, click **Crane Tip Trajectory**.
- 2 In the **Settings** window for **ID Plot Group**, locate the **Title** section.
- 3 From the **Title type** list, choose **None**.
- 4 Locate the **Axis** section. Select the **Preserve aspect ratio** checkbox.
- 5 In the **Crane Tip Trajectory** toolbar, click  **Plot**.