



Model created in COMSOL Multiphysics 6.4

Slider Crank Mechanism with Joint Clearance

Introduction

Joints between two components of a mechanical system are not always perfectly fitting. For the ease of assembly and to allow relative movement between the components, a small gap called clearance is provided between the joining components. The presence of clearance on joints can sometimes adversely affect the performance of the system by generating impact forces thus giving rise to noise and vibrations.

This model compares the performance of a slider crank mechanism with and without a joint clearance. All components of the mechanism are assumed rigid. Hinge Joint node is used when there is no clearance on a joint whereas Clearance Joint node is used to include clearance on a joint. A transient analysis is performed to analyze the effect of joint clearance on slider velocity, slider acceleration, and crank moment. In addition to this, the dynamics of journal within the bearing and the reaction force in the clearance joint are also analyzed.

Model Definition

As shown in [Figure 1](#), the model geometry consists of four rigid components: support, crank, connecting rod, and slider.

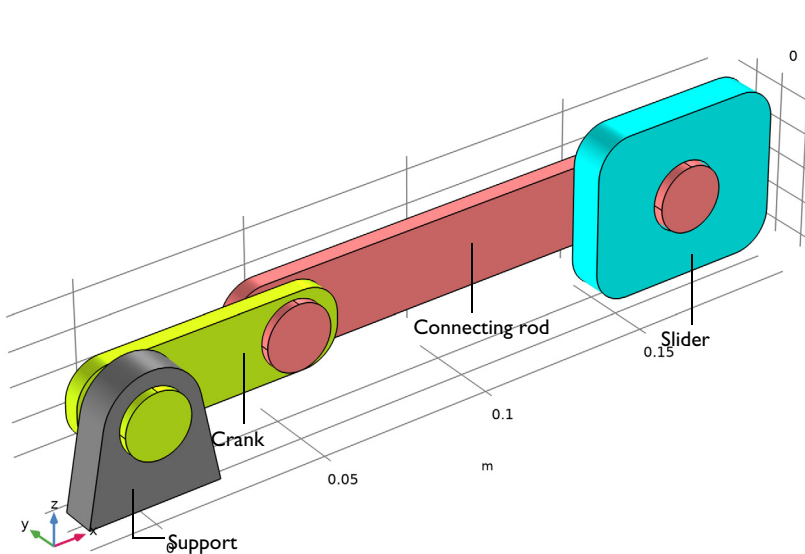

Figure 1: Model geometry of a slider crank mechanism.

One end of the crank is connected to the fixed support and other end to the connecting rod. Connecting rod, in turn, is connected to the center of the slider, which can slide freely along x direction.

The connection between the support and crank is modeled as a hinge joint with one rotational degree of freedom about y -axis. A similar hinge joint is used to model the connection between crank and connecting rod also. To model the connection between connecting rod journal and slider, two different cases are considered:

- In the first case, a perfect hinge joint without any clearance is assumed between journal and the slider.
- In the second case, a clearance of 0.5 mm is provided between journal and the slider. A clearance joint is used to model this connection, which allows the connected members to move within the provided clearance distance.

The mechanism is driven by the crank which rotates with an angular velocity of 5000 rpm. A time dependent study is performed for 25 ms to analyze the effect of joint clearance on slider velocity, slider acceleration, and crank moment.

Results and Discussion

Figure 2 shows the displacement of components in the slider crank mechanism for hinge joint and clearance joint cases. To visualize the motion of connecting rod with respect to the slider, the relative displacement of connecting rod is plotted in Figure 3. For hinge joint case, the relative motion is purely rotational without any translation, however for clearance joint case, connecting rod journal exhibits both translational and rotational motion within the slider hole. This trajectory of the journal within the slider hole is plotted in Figure 7.

The time variation of slider velocity is plotted in Figure 4. It is observed that the velocity profile in hinge joint case is smoother compared to the clearance joint case. Unlike the continuous contact in hinge joint, the translation and the consequent impact of journal with the slider generate a step like velocity profile in clearance joint case. As shown in Figure 5 and Figure 6, the impact between journal and slider also causes sudden variations in slider acceleration and reaction moment in the crank.

Figure 8 shows the variation in clearance joint force as a function of time. The zero value of force at times denotes the intermittent contact within the clearance joint. The variation of gap distance with crank rotation is shown in Figure 9. When gap distance is negative (inside magenta circle), journal and slider are in contact and penalty force acts on the bodies to maintain the relative movement of journal within the specified clearance.

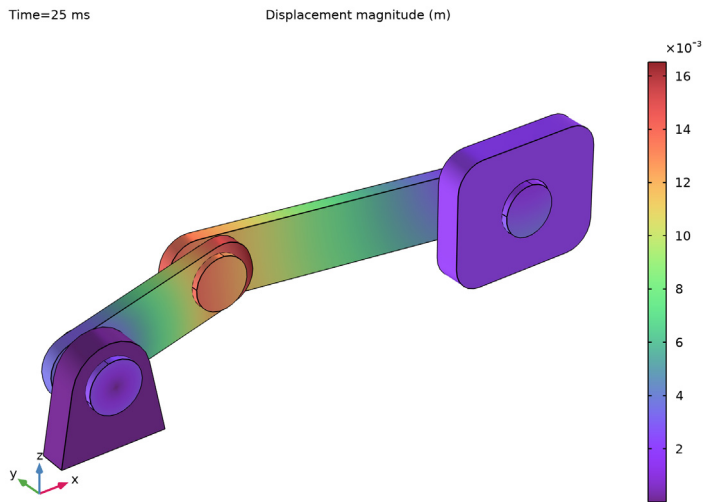
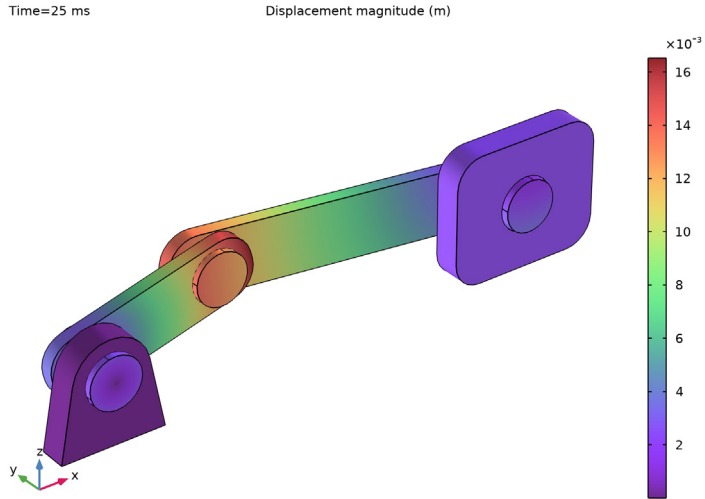

Figure 2: Displacement of the slider crank mechanism for the hinge joint (top) and clearance joint (bottom) cases at $t = 25$ ms.

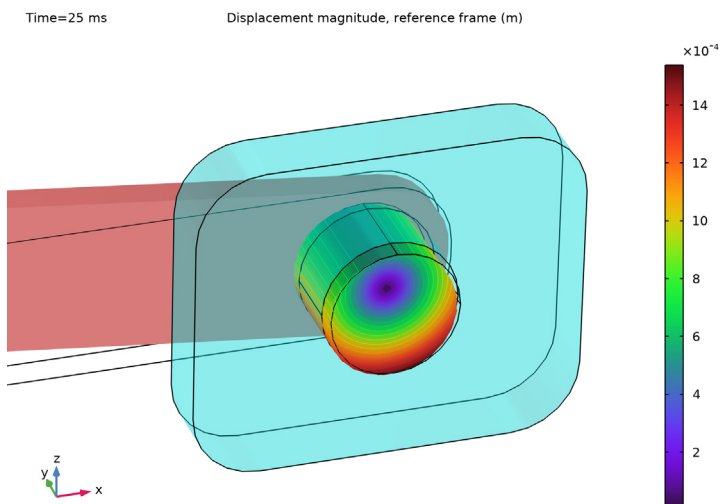
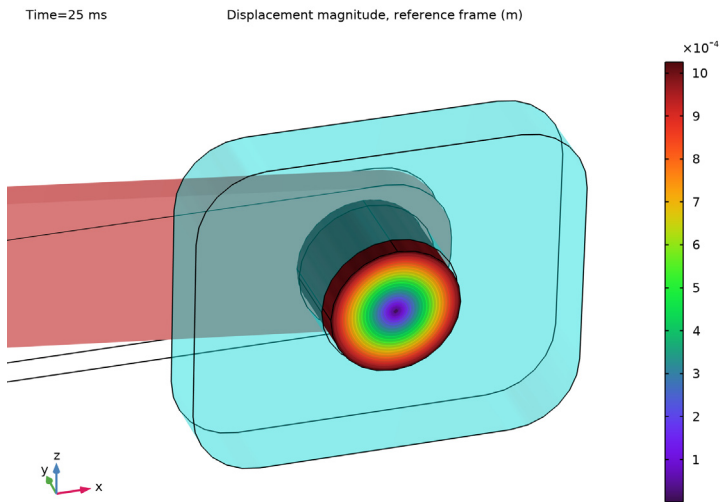

Figure 3: Relative displacement of the connecting rod journal with respect to the slider for the hinge joint (top) and clearance joint (bottom) cases at $t = 25$ ms.

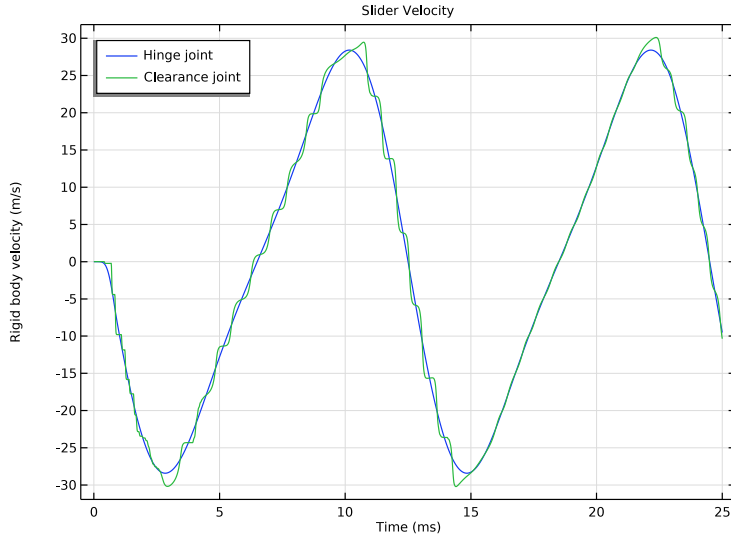

Figure 4: Slider velocity as a function of time for the hinge joint and clearance joint cases.

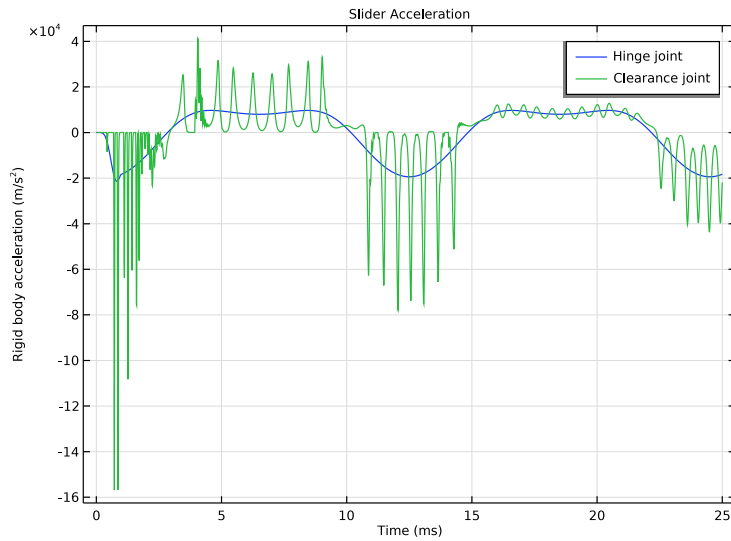

Figure 5: Slider acceleration as a function of time for the hinge joint and clearance joint cases.

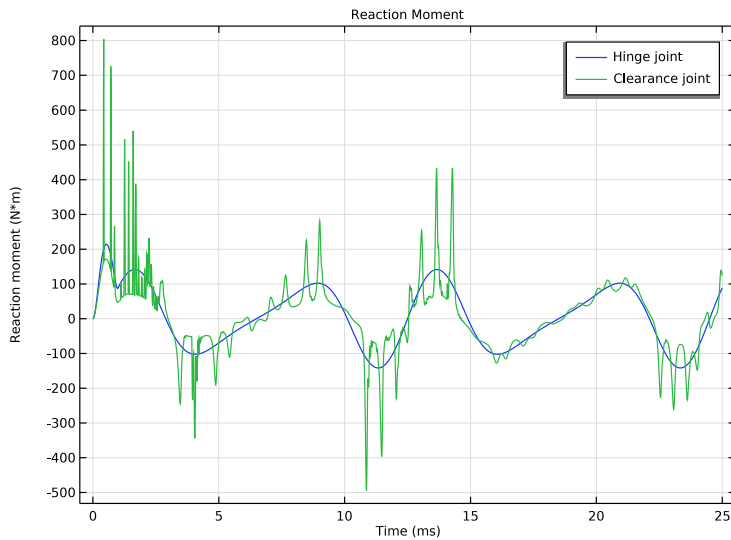

Figure 6: Crank reaction moment as a function of time for the hinge joint and clearance joint cases.

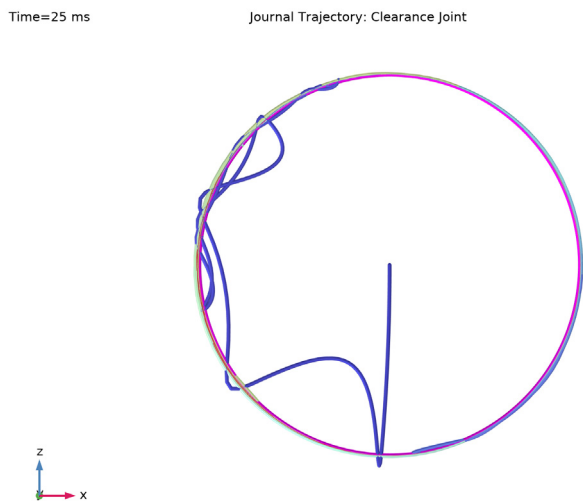

Figure 7: Journal trajectory within the slider hole for the clearance joint. Here blue color denotes the initial position and red color denotes the final position.

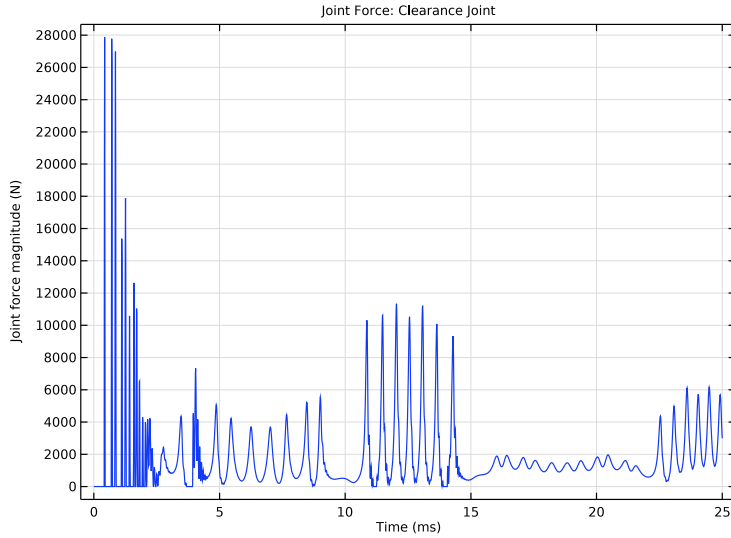

Figure 8: Clearance joint force as a function of time.

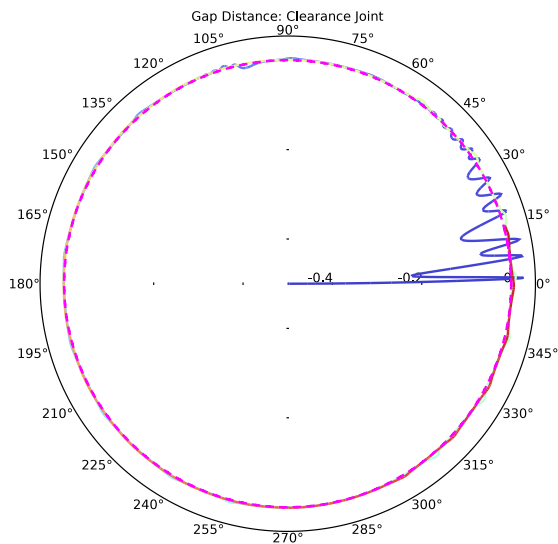

Figure 9: Gap distance as a function of crank rotation for the clearance joint. Here blue color denotes the initial position, red color denotes the final position, and the magenta-dotted circle corresponds to the zero gap distance.

Notes About the COMSOL Implementation

- In this model, linkages are modeled as rigid elements using **Rigid Material** nodes which can be created automatically using the **Create Rigid Domains** button in the **Automated Model Setup** section at the physics interface.
- **Joint** nodes between two respective components can also be created automatically using the **Create Joints** button in the **Automated Model Setup** section at the physics interface. The automatic joint creation requires the geometry to be in assembly mode and **Identity Boundary Pair** nodes to be available in the **Definitions**. In case the geometry does not create an identity pair automatically due to a geometric clearance between the two sets of boundaries, then the identity pair can be created manually in order to create a joint between those two components.

Reference

I. P. Flores and J. Ambrosio, “Revolute Joints with Clearance in Multibody Systems,” *Comput. Struct.*, vol. 82, pp. 1359–1369, 2004.

Application Library path: Multibody_Dynamics_Module/Tutorials/
slider_crank_mechanism_with_clearance



Modeling Instructions

From the **File** menu, choose **New**.

NEW

In the **New** window, click  **Model Wizard**.

MODEL WIZARD

- 1 In the **Model Wizard** window, click  **3D**.
- 2 In the **Select Physics** tree, select **Structural Mechanics > Multibody Dynamics (mbd)**.
- 3 Click **Add**.
- 4 Click  **Study**.
- 5 In the **Select Study** tree, select **General Studies > Time Dependent**.
- 6 Click  **Done**.

GLOBAL DEFINITIONS

Parameters I



- 1 In the **Model Builder** window, under **Global Definitions** click **Parameters I**.
- 2 In the **Settings** window for **Parameters**, locate the **Parameters** section.
- 3 Click  **Load from File**.
- 4 Browse to the model's Application Libraries folder and double-click the file `slider_crank_mechanism_with_clearance_parameters.txt`.

If you do not want to import the geometry and create selections, you can load the geometry sequence from the stored model. In the **Model Builder** window, under **Component I (comp1)** right-click **Geometry I** and choose **Insert Sequence**. Browse to the model's Application Libraries folder and double-click the file `slider_crank_mechanism_with_clearance.mph`. You can then continue to the **Definitions** section below.

To import the geometry and create selections from scratch, continue here.

GEOMETRY I

Import I (impl)

- 1 In the **Model Builder** window, expand the **Component I (comp1) > Geometry I** node.
- 2 Right-click **Geometry I** and choose **Import**.
- 3 In the **Settings** window for **Import**, locate the **Source** section.
- 4 Click  **Browse**.
- 5 Browse to the model's Application Libraries folder and double-click the file `slider_crank_mechanism_with_clearance.mphbin`.
- 6 Click  **Import**.

Form Union (fin)



- 1 In the **Model Builder** window, under **Component I (comp1) > Geometry I** click **Form Union (fin)**.
- 2 In the **Settings** window for **Form Union/Assembly**, locate the **Form Union/Assembly** section.
- 3 From the **Action** list, choose **Form an assembly**.
- 4 In the **Geometry** toolbar, click  **Build All**.

Support



- 1 In the **Geometry** toolbar, click  **Selections** and choose **Explicit Selection**.
- 2 In the **Settings** window for **Explicit Selection**, type **Support** in the **Label** text field.

- 3 On the object **fin**, select Domain 1 only.
- 4 Locate the **Color** section. From the **Color** list, choose **None** or — if you are running the cross-platform desktop —**Custom**. On the cross-platform desktop, click the **Color** button.
- 5 Click **Define custom colors**.
- 6 Set the RGB values to 128, 128, and 128, respectively.
- 7 Click **Add to custom colors**.
- 8 Click **Show color palette only** or **OK** on the cross-platform desktop.
- 9 Click  **Build Selected**.



Crank

- 1 Right-click **Support** and choose **Duplicate**.
- 2 In the **Settings** window for **Explicit Selection**, type Crank in the **Label** text field.
- 3 Locate the **Entities to Select** section. Click the  **Clear Selection** button for **Entities to select**.
- 4 On the object **fin**, select Domains 2 and 3 only.
- 5 Locate the **Color** section. Click **Define custom colors**.
- 6 Set the RGB values to 209, 255, and 28, respectively.
- 7 Click **Add to custom colors**.
- 8 Click **Show color palette only** or **OK** on the cross-platform desktop.
- 9 Click  **Build Selected**.



Connecting Rod

- 1 Right-click **Crank** and choose **Duplicate**.
- 2 In the **Settings** window for **Explicit Selection**, type Connecting Rod in the **Label** text field.
- 3 Locate the **Entities to Select** section. Click the  **Clear Selection** button for **Entities to select**.
- 4 On the object **fin**, select Domains 4–6 only.
- 5 Locate the **Color** section. Click **Define custom colors**.
- 6 Set the RGB values to 255, 128, and 128, respectively.
- 7 Click **Add to custom colors**.
- 8 Click **Show color palette only** or **OK** on the cross-platform desktop.
- 9 Click  **Build Selected**.



Slider

- 1 Right-click **Connecting Rod** and choose **Duplicate**.
- 2 In the **Settings** window for **Explicit Selection**, type **Slider** in the **Label** text field.
- 3 Locate the **Entities to Select** section. Click the  **Clear Selection** button for **Entities to select**.
- 4 On the object **fin**, select Domain 7 only.
- 5 Locate the **Color** section. Click **Define custom colors**.
- 6 Set the RGB values to 0, 255, and 255, respectively.
- 7 Click **Add to custom colors**.
- 8 Click **Show color palette only** or **OK** on the cross-platform desktop.
- 9 Click  **Build Selected**.

Support and Crank

- 1 In the **Geometry** toolbar, click  **Selections** and choose **Union Selection**.
- 2 In the **Settings** window for **Union Selection**, type **Support** and **Crank** in the **Label** text field.
- 3 Locate the **Input Entities** section. Click  **Add**.
- 4 In the **Add** dialog, in the **Selections to add** list, choose **Support** and **Crank**.
- 5 Click **OK**.

Connecting Rod Boundaries

- 1 In the **Geometry** toolbar, click  **Selections** and choose **Adjacent Selection**.
- 2 In the **Settings** window for **Adjacent Selection**, type **Connecting Rod Boundaries** in the **Label** text field.
- 3 Locate the **Input Entities** section. Click  **Add**.
- 4 In the **Add** dialog, select **Connecting Rod** in the **Input selections** list.
- 5 Click **OK**.

Journal Boundaries

- 1 In the **Geometry** toolbar, click  **Selections** and choose **Explicit Selection**.
- 2 In the **Settings** window for **Explicit Selection**, type **Journal Boundaries** in the **Label** text field.
- 3 Locate the **Entities to Select** section. From the **Geometric entity level** list, choose **Boundary**.
- 4 On the object **fin**, select Boundaries 39–41, 47, and 48 only.

Connecting Rod without Journal

- 1 In the **Geometry** toolbar, click  **Selections** and choose **Difference Selection**.
- 2 In the **Settings** window for **Difference Selection**, type Connecting Rod without Journal in the **Label** text field.
- 3 Locate the **Geometric Entity Level** section. From the **Level** list, choose **Boundary**.
- 4 Locate the **Input Entities** section. Click the **+ Add** button for **Selections to add**.
- 5 In the **Add** dialog, select **Connecting Rod Boundaries** in the **Selections to add** list.
- 6 Click **OK**.
- 7 In the **Settings** window for **Difference Selection**, locate the **Input Entities** section.
- 8 Click the **+ Add** button for **Selections to subtract**.
- 9 In the **Add** dialog, select **Journal Boundaries** in the **Selections to subtract** list.
- 10 Click **OK**.

The identity pair between the connecting rod and the slider is not added automatically because of the geometric clearance. Add it manually to allow the automatic joint creation functionality in the Multibody Dynamics interface to create a hinge joint between the two components.

DEFINITIONS

Identity Boundary Pair 3 (p3)

- 1 In the **Model Builder** window, expand the **Component 1 (comp1)** > **Definitions** node.
- 2 Right-click **Definitions** and choose **Pairs** > **Identity Boundary Pair**.
- 3 In the **Settings** window for **Pair**, locate the **Source Boundaries** section.
- 4 From the **Selection** list, choose **Journal Boundaries**.
- 5 Select Boundaries 39, 40, 47, and 48 only.
- 6 Locate the **Destination Boundaries** section. Click to select the  **Activate Selection** toggle button.
- 7 Select Boundaries 54 and 55 only.

Step 1 (step1)

- 1 In the **Definitions** toolbar, click  **More Functions** and choose **Step**.
- 2 In the **Settings** window for **Step**, click to expand the **Smoothing** section.
- 3 Locate the **Parameters** section. In the **Location** text field, type $5e-4$ [s].
- 4 Locate the **Smoothing** section. In the **Size of transition zone** text field, type $1e-3$.

MULTIBODY DYNAMICS (MBD)

Do as follows to generate **Rigid Material** nodes for all components.

- 1 In the **Model Builder** window, under **Component 1 (comp1)** click **Multibody Dynamics (mbd)**.
- 2 In the **Settings** window for **Multibody Dynamics**, locate the **Automated Model Setup** section.
- 3 Select the **Include mass and moment of inertia node** checkbox. This automatically sets the density of all rigid domains to zero and adds a **Mass and Moment of Inertia** subnode to each **Rigid Material** node.
- 4 Click **Physics Node Generation** in the upper-right corner of the **Automated Model Setup** section. From the menu, choose **Create Rigid Domains**.

Rigid Material: Support

- 1 In the **Model Builder** window, expand the **Rigid Domains (All)** node, then click **Rigid Material 1**.
- 2 In the **Settings** window for **Rigid Material**, type Rigid Material: Support in the **Label** text field.

Fixed Constraint 1

In the **Physics** toolbar, click  **Attributes** and choose **Fixed Constraint**.

Rigid Material: Crank

- 1 In the **Model Builder** window, expand the **Component 1 (comp1)** > **Multibody Dynamics (mbd)** > **Rigid Domains (All)** > **Rigid Material 2** node, then click **Rigid Material 2**.
- 2 In the **Settings** window for **Rigid Material**, type Rigid Material: Crank in the **Label** text field.

Mass and Moment of Inertia 1

- 1 In the **Model Builder** window, click **Mass and Moment of Inertia 1**.
- 2 In the **Settings** window for **Mass and Moment of Inertia**, locate the **Mass and Moment of Inertia** section.
- 3 In the *m* text field, type $m1$.
- 4 In the **I** text field, type $I1$.

Rigid Material: Connecting Rod

- 1 In the **Model Builder** window, expand the **Component 1 (comp1)** > **Multibody Dynamics (mbd)** > **Rigid Domains (All)** > **Rigid Material 3** node, then click **Rigid Material 3**.
- 2 In the **Settings** window for **Rigid Material**, type Rigid Material: Connecting Rod in the **Label** text field.

Mass and Moment of Inertia 1

- 1 In the **Model Builder** window, click **Mass and Moment of Inertia 1**.
- 2 In the **Settings** window for **Mass and Moment of Inertia**, locate the **Mass and Moment of Inertia** section.
- 3 In the m text field, type m2.
- 4 In the **I** text field, type I2.

Rigid Material: Slider

- 1 In the **Model Builder** window, expand the **Component 1 (comp1)** > **Multibody Dynamics (mbd)** > **Rigid Domains (All)** > **Rigid Material 4** node, then click **Rigid Material 4**.
- 2 In the **Settings** window for **Rigid Material**, type Rigid Material: Slider in the **Label** text field.

Mass and Moment of Inertia 1

- 1 In the **Model Builder** window, click **Mass and Moment of Inertia 1**.
- 2 In the **Settings** window for **Mass and Moment of Inertia**, locate the **Mass and Moment of Inertia** section.
- 3 In the m text field, type m3.

Rigid Material: Slider

In the **Model Builder** window, click **Rigid Material: Slider**.

Prescribed Displacement/Rotation 1

- 1 In the **Physics** toolbar, click  **Attributes** and choose **Prescribed Displacement/Rotation**.
- 2 In the **Settings** window for **Prescribed Displacement/Rotation**, locate the **Prescribed Displacement at Center of Rotation** section.
- 3 Select the **Prescribed in y direction** checkbox.
- 4 Select the **Prescribed in z direction** checkbox.
- 5 Locate the **Prescribed Rotation** section. From the **By** list, choose **Constrained rotation**.
- 6 Select the **Constrain rotation around x-axis** checkbox.

- 7 Select the **Constrain rotation around y-axis** checkbox.
- 8 Select the **Constrain rotation around z-axis** checkbox.
Do as follows to generate **Hinge Joint** nodes between components.
- 9 In the **Model Builder** window, click **Multibody Dynamics (mbd)**.
- 10 In the **Settings** window for **Multibody Dynamics**, click **Physics Node Generation** in the upper-right corner of the **Automated Model Setup** section. From the menu, choose **Create Joints**.

Hinge Joint 1

In the **Model Builder** window, expand the **Hinge Joints** node, then click **Hinge Joint 1**.

Prescribed Motion 1

- 1 In the **Physics** toolbar, click  **Attributes** and choose **Prescribed Motion**.
- 2 In the **Settings** window for **Prescribed Motion**, locate the **Prescribed Rotational Motion** section.
- 3 From the **Prescribed motion through** list, choose **Angular velocity**.
- 4 In the ω_p text field, type $\text{omega}*\text{step1}(t)$.
- 5 Click to expand the **Reaction Force Settings** section. Select the **Evaluate reaction forces using weak constraints** checkbox.
In order to visualize the motion of the system with respect to the slider, you can define a reference part in the Multibody Dynamics interface and plot the postprocessing variables for displacement and velocity with respect to this reference frame.
- 6 In the **Model Builder** window, click **Multibody Dynamics (mbd)**.
- 7 In the **Settings** window for **Multibody Dynamics**, click to expand the **Results** section.
- 8 From the **Body defining reference frame** list, choose **Rigid Material: Slider**.

MESH 1

Swept 1

In the **Mesh** toolbar, click  **Swept**.

Size

- 1 In the **Model Builder** window, click **Size**.
- 2 In the **Settings** window for **Size**, locate the **Element Size** section.
- 3 From the **Predefined** list, choose **Extra fine**.
- 4 Click  **Build All**.



STUDY 1: HINGE JOINT

- 1 In the **Model Builder** window, click **Study 1**.
- 2 In the **Settings** window for **Study**, type Study 1: Hinge Joint in the **Label** text field.

Step 1: Time Dependent

- 1 In the **Model Builder** window, under **Study 1: Hinge Joint** click **Step 1: Time Dependent**.
- 2 In the **Settings** window for **Time Dependent**, locate the **Study Settings** section.
- 3 From the **Time unit** list, choose **ms**.
- 4 In the **Output times** text field, type range (0,0.01,25).

Solution 1 (sol1)

- 1 In the **Study** toolbar, click  **Show Default Solver**.
- 2 In the **Model Builder** window, expand the **Solution 1 (sol1)** node, then click **Time-Dependent Solver 1**.
- 3 In the **Settings** window for **Time-Dependent Solver**, click to expand the **Time Stepping** section.
- 4 Find the **Algebraic variable settings** subsection. From the **Error estimation** list, choose **Exclude algebraic**.
- 5 In the **Study** toolbar, click  **Compute**.

RESULTS

Click the  **Show Grid** button in the **Graphics** toolbar.

Displacement: Hinge Joint

- 1 In the **Model Builder** window, under **Results** click **Displacement (mbd)**.
- 2 In the **Settings** window for **3D Plot Group**, type Displacement: Hinge Joint in the **Label** text field.

Velocity: Hinge Joint

- 1 In the **Model Builder** window, under **Results** click **Velocity (mbd)**.
- 2 In the **Settings** window for **3D Plot Group**, type Velocity: Hinge Joint in the **Label** text field.

Follow the instructions below to plot the relative displacement in the hinge joint case. The resulting plot should match the one shown in [Figure 3](#).

Relative Displacement: Hinge Joint

- 1 In the **Model Builder** window, right-click **Displacement: Hinge Joint** and choose **Duplicate**.

- 2 In the **Settings** window for **3D Plot Group**, type **Relative Displacement: Hinge Joint** in the **Label** text field.
- 3 Locate the **Plot Settings** section. From the **View** list, choose **New view**.
- 4 From the **Frame** list, choose **Material (X, Y, Z)**.

Surface

- 1 In the **Model Builder** window, expand the **Relative Displacement: Hinge Joint** node, then click **Surface**.
- 2 In the **Settings** window for **Surface**, click **Replace Expression** in the upper-right corner of the **Expression** section. From the menu, choose **Component 1 (comp1) > Multibody Dynamics > Displacement > mbd.disp_ref - Displacement magnitude, reference frame - m**.
- 3 Locate the **Coloring and Style** section. From the **Color table** list, choose **Spectrum**.

Selection 1

Right-click **Surface** and choose **Selection**.

Deformation

In the **Settings** window for **Deformation**, click **Replace Expression** in the upper-right corner of the **Expression** section. From the menu, choose **Component 1 (comp1) > Multibody Dynamics > Displacement > u_ref,...,w_ref - Displacement field, reference frame (spatial frame)**.

Selection 1

- 1 In the **Model Builder** window, click **Selection 1**.
- 2 In the **Settings** window for **Selection**, locate the **Selection** section.
- 3 From the **Selection** list, choose **Journal Boundaries**.

Contour 1

- 1 In the **Model Builder** window, right-click **Relative Displacement: Hinge Joint** and choose **Contour**.
- 2 In the **Settings** window for **Contour**, locate the **Expression** section.
- 3 In the **Expression** text field, type `mbd.disp_ref`.
- 4 Click to expand the **Title** section. From the **Title type** list, choose **None**.
- 5 Locate the **Coloring and Style** section. From the **Color table** list, choose **Spectrum**.
- 6 Clear the **Color legend** checkbox.

Deformation 1

- 1 Right-click **Contour 1** and choose **Deformation**.

- 2 In the **Settings** window for **Deformation**, click **Replace Expression** in the upper-right corner of the **Expression** section. From the menu, choose **Component 1 (comp1) > Multibody Dynamics > Displacement > u_ref,...,w_ref - Displacement field, reference frame (spatial frame)**.
- 3 Locate the **Scale** section.
- 4 Select the **Scale factor** checkbox. In the associated text field, type 1.

Selection 1

- 1 In the **Model Builder** window, right-click **Contour 1** and choose **Selection**.
- 2 In the **Settings** window for **Selection**, locate the **Selection** section.
- 3 From the **Selection** list, choose **Journal Boundaries**.

Surface 2

- 1 In the **Model Builder** window, right-click **Surface** and choose **Duplicate**.
- 2 In the **Settings** window for **Surface**, click **Replace Expression** in the upper-right corner of the **Expression** section. From the menu, choose **Component 1 (comp1) > Geometry > dom - Entity index**.
- 3 Click to expand the **Title** section. From the **Title type** list, choose **None**.
- 4 Locate the **Coloring and Style** section. From the **Coloring** list, choose **Uniform**.
- 5 From the **Color** list, choose **Custom**.
- 6 On Windows, click the colored bar underneath, or — if you are running the cross-platform desktop — the **Color** button.
- 7 Click **Define custom colors**.
- 8 Set the RGB values to 255, 128, and 128, respectively.
- 9 Click **Add to custom colors**.
- 10 Click **Show color palette only** or **OK** on the cross-platform desktop.

Selection 1

- 1 In the **Model Builder** window, expand the **Surface 2** node, then click **Selection 1**.
- 2 In the **Settings** window for **Selection**, locate the **Selection** section.
- 3 From the **Selection** list, choose **Connecting Rod without Journal**.

Volume 1

- 1 In the **Model Builder** window, right-click **Relative Displacement: Hinge Joint** and choose **Volume**.

- 2 In the **Settings** window for **Volume**, click **Replace Expression** in the upper-right corner of the **Expression** section. From the menu, choose **Component 1 (comp1) > Geometry > dom - Entity index**.
- 3 Click to expand the **Title** section. From the **Title type** list, choose **None**.
- 4 Locate the **Coloring and Style** section. From the **Coloring** list, choose **Uniform**.
- 5 From the **Color** list, choose **Cyan**.

Selection 1

- 1 Right-click **Volume 1** and choose **Selection**.
- 2 In the **Settings** window for **Selection**, locate the **Selection** section.
- 3 From the **Selection** list, choose **Slider**.

Transparency 1

- 1 In the **Model Builder** window, right-click **Volume 1** and choose **Transparency**.
- 2 In the **Settings** window for **Transparency**, locate the **Transparency** section.
- 3 Find the **Transparency** subsection. Set the **Transparency** value to **0.75**.

Deformation 1

- 1 Right-click **Volume 1** and choose **Deformation**.
- 2 In the **Settings** window for **Deformation**, click **Replace Expression** in the upper-right corner of the **Expression** section. From the menu, choose **Component 1 (comp1) > Multibody Dynamics > Displacement > u_ref,...,w_ref - Displacement field, reference frame (spatial frame)**.
- 3 Locate the **Scale** section.
- 4 Select the **Scale factor** checkbox. In the associated text field, type 1.

Volume 2

- 1 Right-click **Volume 1** and choose **Duplicate**.
- 2 In the **Settings** window for **Volume**, locate the **Coloring and Style** section.
- 3 From the **Coloring** list, choose **Color table**.
- 4 From the **Color table** list, choose **TrafficLight**.
- 5 Clear the **Color legend** checkbox.

Selection 1

- 1 In the **Model Builder** window, expand the **Volume 2** node, then click **Selection 1**.
- 2 In the **Settings** window for **Selection**, locate the **Selection** section.
- 3 Click  **Clear Selection**.

4 From the **Selection** list, choose **Support and Crank**.

Transparency I

In the **Model Builder** window, right-click **Transparency I** and choose **Delete**.

Relative Displacement: Hinge Joint

1 In the **Model Builder** window, under **Results** click **Relative Displacement: Hinge Joint**.

2 In the **Relative Displacement: Hinge Joint** toolbar, click  **Plot**.

MULTIBODY DYNAMICS (MBD)

Clearance Joint I

1 In the **Physics** toolbar, click  **Global** and choose **Clearance Joint**.

2 In the **Settings** window for **Clearance Joint**, locate the **Attachment Selection** section.

3 From the **Source** list, choose **Rigid Material: Connecting Rod**.

4 From the **Connection point** list, choose **Centroid of selected entities**.

Source Point: Boundary I

1 In the **Model Builder** window, click **Source Point: Boundary I**.

2 In the **Settings** window for **Source Point: Boundary**, locate the **Boundary Selection** section.

3 From the **Selection** list, choose **Journal Boundaries**.

4 In the list box, select **41**.

5 Click  **Remove from Selection**.

6 Select Boundaries 39, 40, 47, and 48 only.

Clearance Joint I

1 In the **Model Builder** window, click **Clearance Joint I**.

2 In the **Settings** window for **Clearance Joint**, locate the **Attachment Selection** section.

3 From the **Destination** list, choose **Rigid Material: Slider**.

4 Locate the **Clearance Settings** section. In the C text field, type C .

5 In the p_j text field, type $1e9[N/m]$.

ADD STUDY

1 In the **Home** toolbar, click  **Add Study** to open the **Add Study** window.

2 Go to the **Add Study** window.

3 Find the **Studies** subsection. In the **Select Study** tree, select **General Studies > Time Dependent**.

- 4 Click the **Add Study** button in the window toolbar.
- 5 In the **Home** toolbar, click  **Add Study** to close the **Add Study** window.



STUDY 2: CLEARANCE JOINT

In the **Settings** window for **Study**, type Study 2: Clearance Joint in the **Label** text field.

Step 1: Time Dependent

- 1 In the **Model Builder** window, under **Study 2: Clearance Joint** click **Step 1: Time Dependent**.
- 2 In the **Settings** window for **Time Dependent**, locate the **Study Settings** section.
- 3 From the **Time unit** list, choose **ms**.
- 4 In the **Output times** text field, type range (0,0.01,25).
- 5 Locate the **Physics and Variables Selection** section. Select the **Modify model configuration for study step** checkbox.
- 6 In the tree, select **Component 1 (comp1) > Multibody Dynamics (mbd), Controls spatial frame > Hinge Joints > Hinge Joint 3**.
- 7 Right-click and choose **Disable**.

Solution 2 (sol2)

- 1 In the **Study** toolbar, click  **Show Default Solver**.
- 2 In the **Model Builder** window, expand the **Solution 2 (sol2)** node, then click **Time-Dependent Solver 1**.
- 3 In the **Settings** window for **Time-Dependent Solver**, locate the **Time Stepping** section.
- 4 Find the **Algebraic variable settings** subsection. From the **Error estimation** list, choose **Exclude algebraic**.
- 5 In the **Study** toolbar, click  **Compute**.

RESULTS

Displacement: Clearance Joint

In the **Settings** window for **3D Plot Group**, type Displacement: Clearance Joint in the **Label** text field.

Velocity: Clearance Joint

- 1 In the **Model Builder** window, under **Results** click **Velocity (mbd)**.
- 2 In the **Settings** window for **3D Plot Group**, type Velocity: Clearance Joint in the **Label** text field.

Follow the instructions below to plot the relative displacement in the clearance joint case. The resulting plot should match the one shown in [Figure 3](#).

Relative Displacement: Clearance Joint

- 1 In the **Model Builder** window, right-click **Relative Displacement: Hinge Joint** and choose **Duplicate**.
- 2 In the **Settings** window for **3D Plot Group**, type Relative Displacement: Clearance Joint in the **Label** text field.
- 3 Locate the **Data** section. From the **Dataset** list, choose **Study 2: Clearance Joint/Solution 2 (sol2)**.
- 4 In the **Relative Displacement: Clearance Joint** toolbar, click  **Plot**.

Follow the instructions below to plot the slider velocity. The resulting plot should match the one shown in [Figure 4](#).

Slider Velocity

- 1 In the **Results** toolbar, click  **ID Plot Group**.
- 2 In the **Settings** window for **ID Plot Group**, type Slider Velocity in the **Label** text field.
- 3 Click to expand the **Title** section. From the **Title type** list, choose **Label**.
- 4 Locate the **Legend** section. From the **Position** list, choose **Upper left**.

Global 1

- 1 Right-click **Slider Velocity** and choose **Global**.
- 2 In the **Settings** window for **Global**, click **Replace Expression** in the upper-right corner of the **y-Axis Data** section. From the menu, choose **Component 1 (comp1) > Multibody Dynamics > Rigid domains > Rigid Material: Slider > Rigid body velocity (spatial frame) - m/s > mbd.rd4.u_tx - Rigid body velocity, x-component**.
- 3 Locate the **y-Axis Data** section. In the table, enter the following settings:

Expression	Unit	Description
mbd.rd4.u_tx	m/s	Hinge joint

Global 2

- 1 Right-click **Global 1** and choose **Duplicate**.
- 2 In the **Settings** window for **Global**, locate the **Data** section.
- 3 From the **Dataset** list, choose **Study 2: Clearance Joint/Solution 2 (sol2)**.

4 Locate the **y-Axis Data** section. In the table, enter the following settings:

Expression	Unit	Description
mbd.rd4.u_tx	m/s	Clearance joint

Slider Velocity

- 1 In the **Model Builder** window, click **Slider Velocity**.
- 2 In the **Settings** window for **ID Plot Group**, locate the **Plot Settings** section.
- 3 Select the **y-axis label** checkbox. In the associated text field, type Rigid body velocity (m/s).
- 4 In the **Slider Velocity** toolbar, click  **Plot**.

Follow the instructions below to plot the slider acceleration. The resulting plot should match the one shown in [Figure 5](#).

Slider Acceleration

- 1 Right-click **Slider Velocity** and choose **Duplicate**.
- 2 In the **Settings** window for **ID Plot Group**, type Slider Acceleration in the **Label** text field.
- 3 Locate the **Plot Settings** section. In the **y-axis label** text field, type Rigid body acceleration (m/s²).
- 4 Locate the **Legend** section. From the **Position** list, choose **Upper right**.

Global 1

- 1 In the **Model Builder** window, expand the **Slider Acceleration** node, then click **Global 1**.
- 2 In the **Settings** window for **Global**, locate the **y-Axis Data** section.
- 3 In the table, enter the following settings:

Expression	Unit	Description
mbd.rd4.u_ttx	m/s ²	Hinge joint

Global 2

- 1 In the **Model Builder** window, click **Global 2**.
- 2 In the **Settings** window for **Global**, locate the **y-Axis Data** section.
- 3 In the table, enter the following settings:

Expression	Unit	Description
mbd.rd4.u_ttx	m/s ²	Clearance joint

Follow the instructions below to plot the crank reaction moment. The resulting plot should match the one shown in [Figure 6](#).

Reaction Moment

- 1 In the **Model Builder** window, right-click **Slider Acceleration** and choose **Duplicate**.
- 2 In the **Settings** window for **ID Plot Group**, type Reaction Moment in the **Label** text field.
- 3 Locate the **Plot Settings** section. In the **y-axis label** text field, type Reaction moment (N*m).

Global 1

- 1 In the **Model Builder** window, expand the **Reaction Moment** node, then click **Global 1**.
- 2 In the **Settings** window for **Global**, locate the **y-Axis Data** section.
- 3 In the table, enter the following settings:

Expression	Unit	Description
mbd.hgj1.pm1.RM	N*m	Hinge joint

Global 2

- 1 In the **Model Builder** window, click **Global 2**.
- 2 In the **Settings** window for **Global**, locate the **y-Axis Data** section.
- 3 In the table, enter the following settings:

Expression	Unit	Description
mbd.hgj1.pm1.RM	N*m	Clearance joint

- 4 In the **Reaction Moment** toolbar, click  **Plot**.

Follow the instructions below to plot the journal trajectory in the clearance joint. The resulting plot should match the one shown in [Figure 7](#).

Journal Trajectory: Clearance Joint

- 1 In the **Results** toolbar, click  **3D Plot Group**.
- 2 In the **Settings** window for **3D Plot Group**, type Journal Trajectory: Clearance Joint in the **Label** text field.
- 3 Locate the **Data** section. From the **Dataset** list, choose **Study 2: Clearance Joint/ Solution 2 (sol2)**.
- 4 Click to expand the **Title** section. From the **Title type** list, choose **Label**.
- 5 Locate the **Plot Settings** section. From the **View** list, choose **New view**.
- 6 Clear the **Plot dataset edges** checkbox.

Point Trajectories 1

- 1 In the **Journal Trajectory: Clearance Joint** toolbar, click  **More Plots** and choose **Point Trajectories**.
- 2 In the **Settings** window for **Point Trajectories**, locate the **Trajectory Data** section.
- 3 From the **Plot data** list, choose **Global**.
- 4 Click **Replace Expression** in the upper-right corner of the **Trajectory Data** section. From the menu, choose **Component 1 (comp1) > Multibody Dynamics > Clearance joints > Clearance Joint 1 > mbd.crj1.dx,...,mbd.crj1.dz - Instantaneous distance**.
- 5 Locate the **Coloring and Style** section. Find the **Line style** subsection. From the **Type** list, choose **Tube**.
- 6 In the **Tube radius expression** text field, type $1e-8$.
- 7 Select the **Radius scale factor** checkbox. In the associated text field, type 500.

Color Expression 1



- 1 Right-click **Point Trajectories 1** and choose **Color Expression**.
- 2 In the **Settings** window for **Color Expression**, locate the **Expression** section.
- 3 In the **Expression** text field, type t .
- 4 Locate the **Coloring and Style** section. From the **Color table** list, choose **RainbowLight**.
- 5 Clear the **Color legend** checkbox.

Parametric Curve 3D 1

- 1 In the **Results** toolbar, click  **More Datasets** and choose **Parametric Curve 3D**.
- 2 In the **Settings** window for **Parametric Curve 3D**, locate the **Data** section.
- 3 From the **Dataset** list, choose **Study 2: Clearance Joint/Solution 2 (sol2)**.
- 4 Locate the **Parameter** section. In the **Maximum** text field, type $2*\pi$.
- 5 Locate the **Expressions** section. In the **x** text field, type $C*s\sin(s)$.
- 6 In the **z** text field, type $C*\cos(s)$.

Line 1

- 1 In the **Model Builder** window, right-click **Journal Trajectory: Clearance Joint** and choose **Line**.
- 2 In the **Settings** window for **Line**, locate the **Data** section.
- 3 From the **Dataset** list, choose **Parametric Curve 3D 1**.
- 4 Locate the **Expression** section. In the **Expression** text field, type 1.
- 5 Locate the **Coloring and Style** section. From the **Line type** list, choose **Tube**.

- 6 In the **Tube radius expression** text field, type $1e-8$.
- 7 Select the **Radius scale factor** checkbox. In the associated text field, type 500.
- 8 From the **Coloring** list, choose **Uniform**.
- 9 From the **Color** list, choose **Magenta**.
- 10 In the **Journal Trajectory: Clearance Joint** toolbar, click  **Plot**.
- 11 Click the  **Zoom Extents** button in the **Graphics** toolbar.

Follow the instructions below to plot the clearance joint force. The resulting plot should match the one shown in [Figure 8](#).

Joint Force: Clearance Joint

- 1 In the **Results** toolbar, click  **ID Plot Group**.
- 2 In the **Settings** window for **ID Plot Group**, type Joint Force: Clearance Joint in the **Label** text field.
- 3 Locate the **Data** section. From the **Dataset** list, choose **Study 2: Clearance Joint/ Solution 2 (sol2)**.
- 4 Locate the **Title** section. From the **Title type** list, choose **Label**.
- 5 Locate the **Legend** section. Clear the **Show legends** checkbox.

Global I

- 1 Right-click **Joint Force: Clearance Joint** and choose **Global**.
- 2 In the **Settings** window for **Global**, click **Replace Expression** in the upper-right corner of the **y-Axis Data** section. From the menu, choose **Component 1 (comp1) > Multibody Dynamics > Clearance joints > Clearance Joint 1 > mbd.crj1.Fj - Joint force magnitude - N**.
- 3 In the **Joint Force: Clearance Joint** toolbar, click  **Plot**.

Follow the instructions below to plot the gap distance in clearance joint. The resulting plot should match the one shown in [Figure 9](#).

Gap Distance: Clearance Joint

- 1 In the **Results** toolbar, click  **Polar Plot Group**.
- 2 In the **Settings** window for **Polar Plot Group**, type Gap Distance: Clearance Joint in the **Label** text field.
- 3 Locate the **Data** section. From the **Dataset** list, choose **Study 2: Clearance Joint/ Solution 2 (sol2)**.
- 4 Click to expand the **Title** section. From the **Title type** list, choose **Label**.

- 5 Locate the **Grid** section. Clear the **Show grid** checkbox.
- 6 Locate the **Legend** section. Clear the **Show legends** checkbox.

Global 1

- 1 Right-click **Gap Distance: Clearance Joint** and choose **Global**.
- 2 In the **Settings** window for **Global**, locate the **r-Axis Data** section.
- 3 In the table, enter the following settings:

Expression	Unit	Description
-mbd.crj1.gap	mm	Gap distance

- 4 Locate the θ **Angle Data** section. From the **Parameter** list, choose **Expression**.
- 5 In the **Expression** text field, type `mbd.hgj1.th`.
- 6 Click to expand the **Coloring and Style** section. From the **Width** list, choose **2**.

Global 2

- 1 Right-click **Global 1** and choose **Duplicate**.
Add a dotted line indicating zero gap distance in the clearance joint.
- 2 In the **Settings** window for **Global**, locate the **r-Axis Data** section.
- 3 In the table, enter the following settings:

Expression	Unit	Description
0 [mm]	mm	Zero gap

- 4 Locate the **Coloring and Style** section. Find the **Line style** subsection. From the **Line** list, choose **Dotted**.
- 5 From the **Color** list, choose **Magenta**.

Color Expression 1

- 1 In the **Model Builder** window, right-click **Global 1** and choose **Color Expression**.
- 2 In the **Settings** window for **Color Expression**, locate the **Expression** section.
- 3 In the **Expression** text field, type `t`.
- 4 Locate the **Coloring and Style** section. From the **Color table** list, choose **RainbowLight**.
- 5 In the **Gap Distance: Clearance Joint** toolbar, click  **Plot**.

Displacement: Hinge Joint

- 1 In the **Results** toolbar, click  **Animation** and choose **Player**.

2 In the **Settings** window for **Animation**, type Displacement: Hinge Joint in the **Label** text field.

3 Locate the **Frames** section. In the **Number of frames** text field, type 50.

Displacement: Clearance Joint

1 Right-click **Displacement: Hinge Joint** and choose **Duplicate**.

2 In the **Settings** window for **Animation**, type Displacement: Clearance Joint in the **Label** text field.

3 Locate the **Scene** section. From the **Subject** list, choose **Displacement: Clearance Joint**.

Relative Displacement: Hinge Joint

1 In the **Model Builder** window, right-click **Displacement: Hinge Joint** and choose **Duplicate**.

2 In the **Settings** window for **Animation**, type Relative Displacement: Hinge Joint in the **Label** text field.

3 Locate the **Scene** section. From the **Subject** list, choose **Relative Displacement: Hinge Joint**.

Relative Displacement: Clearance Joint

1 Right-click **Relative Displacement: Hinge Joint** and choose **Duplicate**.

2 In the **Settings** window for **Animation**, type Relative Displacement: Clearance Joint in the **Label** text field.

3 Locate the **Scene** section. From the **Subject** list, choose **Relative Displacement: Clearance Joint**.

Journal Trajectory: Clearance Joint

1 Right-click **Relative Displacement: Clearance Joint** and choose **Duplicate**.

2 In the **Settings** window for **Animation**, type Journal Trajectory: Clearance Joint in the **Label** text field.

3 Locate the **Scene** section. From the **Subject** list, choose **Journal Trajectory: Clearance Joint**.