



Model created in COMSOL Multiphysics 6.4

# Mechanism Submerged in Fluid

## *Introduction*

---

Fluid-structure interaction (FSI) is a common class of multiphysics problems. The coupling is in general bidirectional; the fluid exerts an external load on the structure, leading to deformation of structural components, and, conversely, the motion or deformation of the structural components changes the flow field. Depending on the type of interaction between fluids and solid objects, FSI problems can be categorized as either one-way problems or fully coupled problems.

This example demonstrates the dynamics of a moving mechanism, with two rotating fins, submerged in a fluid channel. The fluid domain is modeled using the Laminar Flow interface, and the mechanism is modeled using the Multibody Dynamics interface. A **Fluid-Structure Interaction, Pair** multiphysics coupling is used to model the interaction between the fluid and solid domains, and an ALE formulation through a **Moving Mesh** node is used to control the geometrical changes of the fluid domain. A time-dependent study is used to simulate the forward motion of the mechanism through the fluid channel induced by the fin rotation.

## *Model Definition*

---

The model geometry consists of a mechanism with a central body and two fins. The mechanism is submerged in a flow channel. The fins are located at the back of the body, symmetrically placed on both sides of the longitudinal axis at an initial angle of  $30^\circ$ . The fins are connected to the central body through hinge joints, which allow in-plane rotation of the fins, as shown in [Figure 1](#). The mechanism is submerged in a flow channel of 25 cm width, 15 cm depth, and 5 cm height.

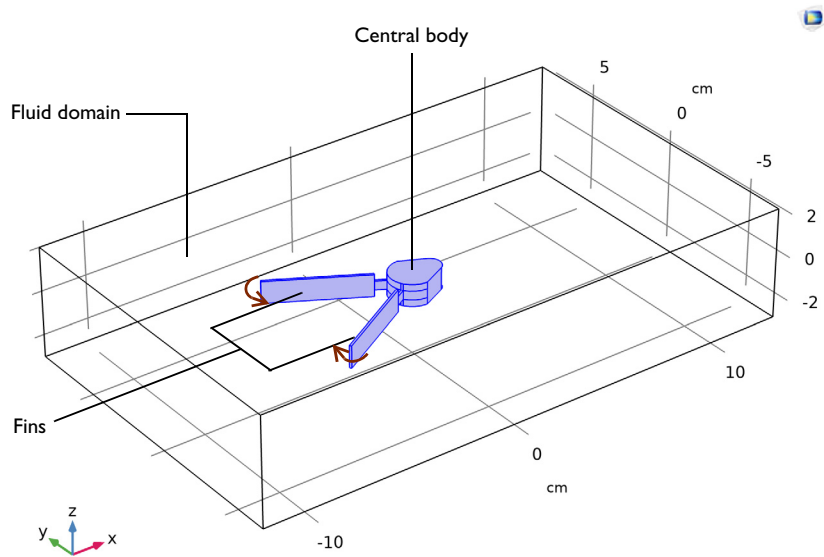

Figure 1: Geometry of the mechanism submerged in a fluid channel.

## MATERIALS

The components of the mechanism are built of structural steel and the fluid around the mechanism is taken as water.

## FLUID-STRUCTURE INTERACTION

The interaction between the fluid and the solid domains is modeled using a Fluid-Multibody Interaction, Assembly interface. This interface consists of a predefined Laminar Flow interface, a Multibody Dynamics interface, and a **Moving Mesh** node with a **Deforming Domain** subnode. In addition, a **Multiphysics Couplings** node is added. It contains the multiphysics coupling **Fluid-Structure Interaction, Pair**. Additional details about the interface can be found in the documentation for multiphysics couplings in the *Multibody Dynamics Module User's Guide*.

The interaction between the fluid and the structural mechanism is specified through the interface boundaries between the two domains. The two identity pairs between the fluid and solid domains are selected in the **Fluid-Structure Interaction, Pair** node to incorporate the multiphysics coupling between the two physics.

## FLUID FLOW

The fluid in the channel is described by the incompressible Navier–Stokes equations for the velocity field and the pressure in the spatial (deformed) coordinate system. A **Pressure Point Constraint** is used at one of the corner points of the fluid domain, setting the value of the pressure to zero at this point.

## MULTIBODY DYNAMICS

The Multibody Dynamics interface is used to model the structural assembly. In this analysis, the solid central body is assumed to be a rigid object, while the fins are modeled as flexible bodies. The motion of the mechanism is initiated by a prescribed rotation of the fins about the central body in a time-dependent manner. The rotation is prescribed in such a way that during the initial 0.25 s, the fins rotate toward each other, resulting in the closing of the mechanism. After 0.25 s, their rotation is kept constant at 15°. [Figure 7](#) shows the rotation of the fins as a function of time.

## MOVING MESH

The geometrical changes in the fluid domain are modeled using an ALE formulation. A deforming-domain condition is assigned to the fluid domain, where the shape of the domain is controlled by the moving boundaries and a smoothing equation in the interior. In the present example, two types of mesh boundary conditions are used to specify the motion of the spatial mesh:

- On all fluid-solid interface boundaries, except at the curved boundaries at the back of the solid body, a **Prescribed Mesh Displacement** boundary condition is used to transfer the motion of the adjoining solid to the moving mesh. As shown in [Figure 2](#), this boundary condition sets the displacement of the mesh boundaries equal to the mapped solid boundaries of the identity pairs.
- At the back side of the solid body as shown in [Figure 3](#), the contact area between solid and fluid boundaries continuously changes because of the rotational motion of the fins. Using a **Prescribed Normal Mesh Displacement** boundary condition at these boundaries, allows the mesh to move freely in the tangential direction and to follow the solid normal motion in the normal direction.

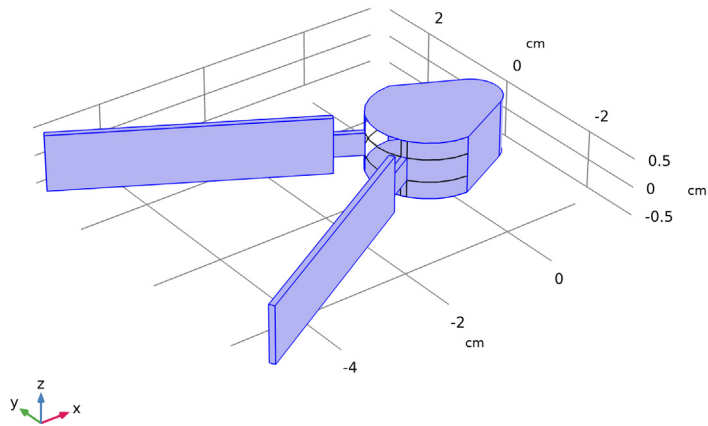

Figure 2: Solid motion (all components) transferred to the moving mesh boundaries.

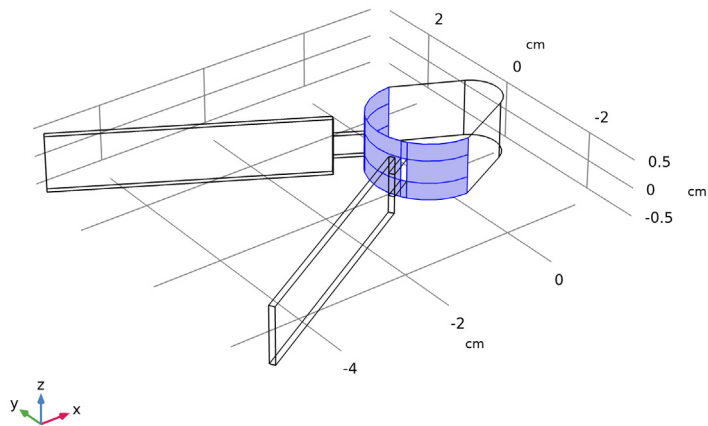

Figure 3: Normal component of solid motion transferred to the moving mesh boundaries. The mesh is free to slide in these boundaries in the tangential direction.

## **STUDY**

A time dependent study is performed for 1 s to analyze the interaction of the mechanism and the fluid.

## *Results and Discussion*

---

The velocity field and pressure distribution in the central  $xy$ -plane of the fluid domain are plotted in [Figure 4](#) for six different time steps. Additionally, the variation of the structural displacement and velocity are plotted for each of these time steps. A similar plot for the distribution of the fluid velocity and pressure in the central  $xz$ -plane at  $t = 0.3$  s is shown in [Figure 5](#).

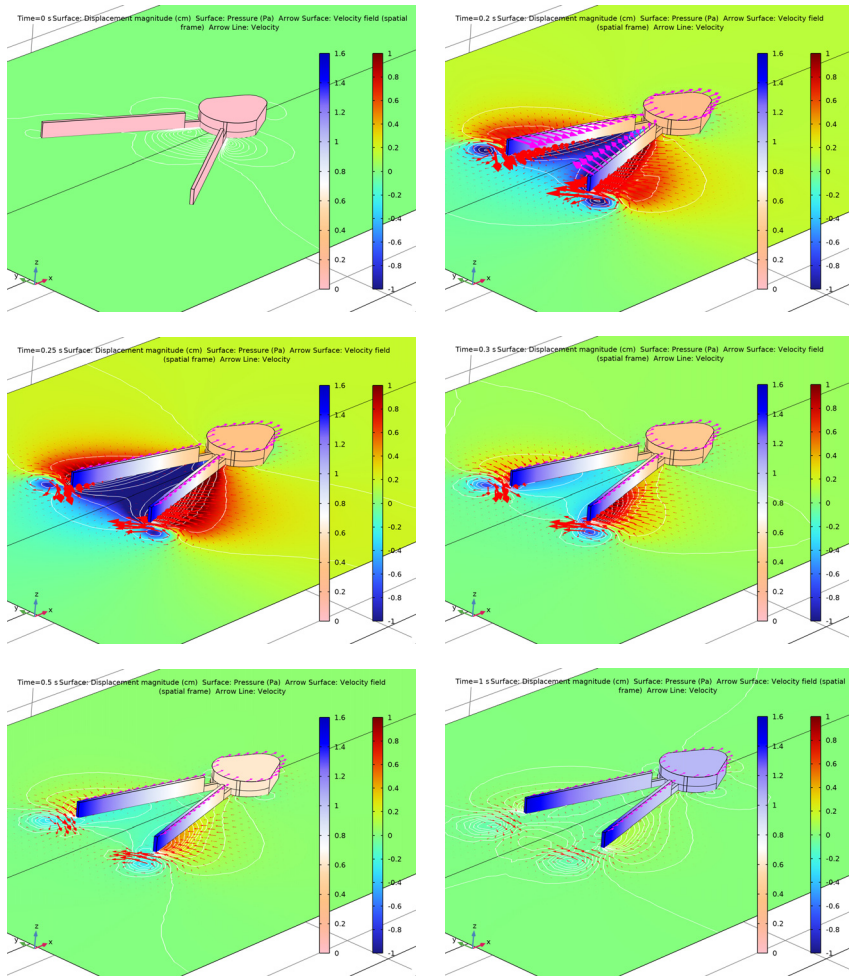

*Figure 4: Velocity field (arrow) and pressure (surface) in the fluid in the xy-plane together with displacement (surface) and velocity (arrow) in the mechanism at different time steps.*

The time-dependent rotational motion of the fins are shown in [Figure 7](#). Initially, when the fins start to rotate and approach each other, they force the surrounding fluid either to compress or expand. After  $t = 0.25$  s, the rotation of the fins are kept at a constant angle of  $15^\circ$ . The transmission of velocity from the structure to the fluid results in a net forward motion of the structure as shown in [Figure 7](#).

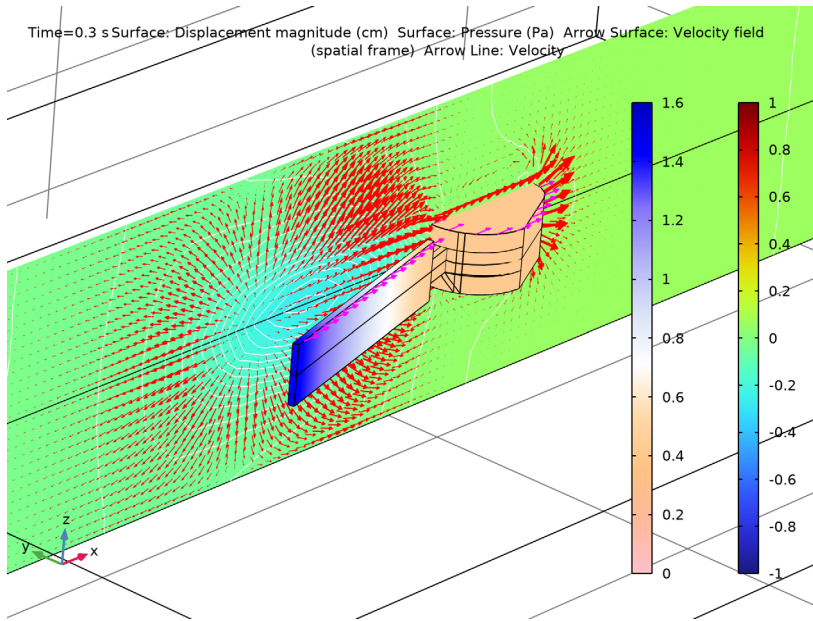

Figure 5: Velocity field (arrow) and pressure (surface) in the fluid in the  $xz$ -plane together with displacement (surface) and velocity (arrow) in the mechanism at  $t = 0.3$  s.

Figure 6 shows the finite-element mesh in the mechanism and the lower half of the fluid domain at the initial and final time steps. Because of the forward motion of the structure in the  $x$  direction, you can observe a stretching of the elements in this direction in the deformed mesh plot. If the displacements were even larger, remeshing would have to be considered.

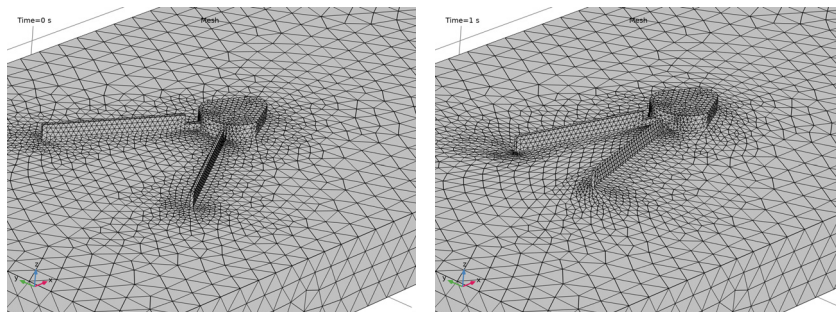

Figure 6: Mesh at  $t = 0$  and  $1$  s.

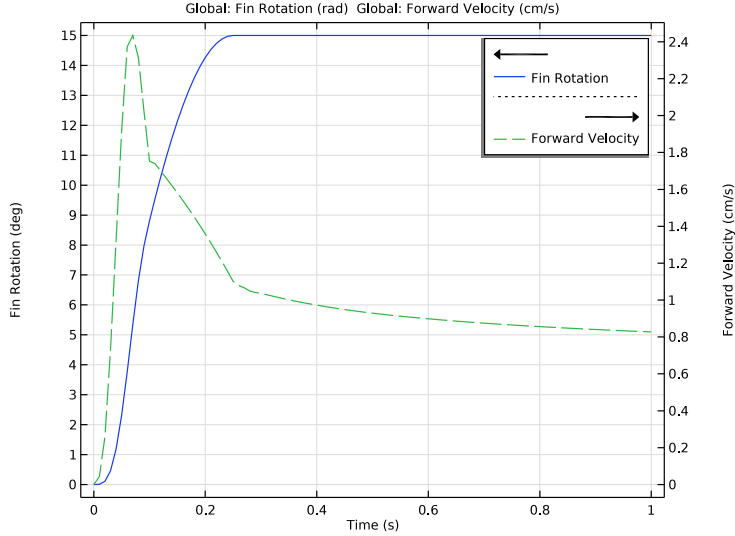

Figure 7: Fin rotation and forward velocity of the mechanism as functions of time.

### Notes About the COMSOL Implementation

- The **Fluid-Structure Interaction, Pair** node operates on the geometry in the assembly state. Pairs between different geometry parts can then be automatically generated.
- All the pairs in the geometry appear in the **Pair Selection** section of the **Fluid-Structure Interaction, Pair** node. Select only those pairs which couple the fluid and solid physics interfaces.
- In order to transfer the deformation of the solid to the moving mesh, the built-in variables (`fsip1.u_solid`, `fsip1.v_solid`, and `fsip1.w_solid`) are available. These variables are equal to the solid displacement.

---

**Application Library path:** Multibody\_Dynamics\_Module/Tutorials/mechanism\_submerged\_in\_fluid

---



### Modeling Instructions

From the **File** menu, choose **New**.

## NEW

In the **New** window, click  **Model Wizard**.

## MODEL WIZARD

- 1 In the **Model Wizard** window, click .
- 2 In the **Select Physics** tree, select **Fluid Flow** > **Fluid–Structure Interaction** > **Fluid–Multibody Interaction, Assembly**.
- 3 Click **Add**.
- 4 Click  **Study**.
- 5 In the **Select Study** tree, select **General Studies** > **Time Dependent**.
- 6 Click  **Done**.

## GLOBAL DEFINITIONS

### *Parameters I*

- 1 In the **Model Builder** window, under **Global Definitions** click **Parameters I**.
- 2 In the **Settings** window for **Parameters**, locate the **Parameters** section.
- 3 In the table, enter the following settings:



Name	Expression	Value	Description
th_max	15[deg]	0.2618 rad	Maximum fin rotation

## GEOMETRY I



- 1 In the **Model Builder** window, under **Component I (comp1)** click **Geometry I**.
- 2 In the **Settings** window for **Geometry**, locate the **Units** section.
- 3 From the **Length unit** list, choose **cm**.

### *Import I (impl)*



You can import the geometry of the mechanism by browsing to the model's Application Libraries folder.

- 1 In the **Geometry** toolbar, click  **Import**.
- 2 In the **Settings** window for **Import**, locate the **Source** section.
- 3 Click  **Browse**.
- 4 Browse to the model's Application Libraries folder and double-click the file `mechanism_submerged_in_fluid.mphbin`.
- 5 Click  **Import**.

### *Copy 1 (copy1)*

- 1 In the **Geometry** toolbar, click  **Transforms** and choose **Copy**.
- 2 Click in the **Graphics** window and then press Ctrl+A to select both objects.
- 3 In the **Settings** window for **Copy**, click  **Build Selected**.

### *Block 1 (blk1)*

- 1 In the **Geometry** toolbar, click  **Block**.
- 2 In the **Settings** window for **Block**, locate the **Size and Shape** section.
- 3 In the **Width** text field, type 25.
- 4 In the **Depth** text field, type 15.
- 5 In the **Height** text field, type 5.
- 6 Locate the **Position** section. From the **Base** list, choose **Center**.
- 7 Click  **Build Selected**.



### *Work Plane 1 (wp1)*

- 1 In the **Geometry** toolbar, click  **Work Plane**.
- 2 In the **Settings** window for **Work Plane**, click  **Build Selected**.

### *Work Plane 2 (wp2)*

- 1 Right-click **Work Plane 1 (wp1)** and choose **Duplicate**.
- 2 In the **Settings** window for **Work Plane**, locate the **Plane Definition** section.
- 3 From the **Plane** list, choose **xz-plane**.
- 4 Click  **Build Selected**.

### *Partition Domains 1 (pard1)*

- 1 In the **Geometry** toolbar, click  **Booleans and Partitions** and choose **Partition Domains**.
- 2 On the object **blk1**, select Domain 1 only.
- 3 In the **Settings** window for **Partition Domains**, locate the **Partition Domains** section.
- 4 From the **Work plane** list, choose **Work Plane 1 (wp1)**.
- 5 Click  **Build Selected**.

### *Partition Domains 2 (pard2)*

- 1 Right-click **Partition Domains 1 (pard1)** and choose **Duplicate**.
- 2 On the object **pard1**, select Domains 1 and 2 only.
- 3 In the **Settings** window for **Partition Domains**, locate the **Partition Domains** section.

4 From the **Work plane** list, choose **Work Plane 2 (wp2)**.

5 Click  **Build Selected**.

#### *Difference 1 (dif1)*

1 In the **Geometry** toolbar, click  **Booleans and Partitions** and choose **Difference**.

2 Select the object **pard2** only.

3 In the **Settings** window for **Difference**, locate the **Difference** section.

4 Click to select the  **Activate Selection** toggle button for **Objects to subtract**.

5 Select the objects **copy1(1)** and **copy1(2)** only.

6 Click  **Build Selected**.

#### *Form Union (fin)*

1 In the **Model Builder** window, under **Component 1 (comp1) > Geometry 1** click **Form Union (fin)**.

2 In the **Settings** window for **Form Union/Assembly**, locate the **Form Union/Assembly** section.

3 From the **Action** list, choose **Form an assembly**.



4 From the **Frame for identity pairs** list, choose **Material (X, Y, Z)**.

5 Click  **Build Selected**.

For better visualization, you can hide the top part of the fluid domain and view the mechanism using wireframe rendering.

6 In the **Model Builder** window, click **Geometry 1**.

7 Click the  **Click and Hide** button in the **Graphics** toolbar.

8 In the **Graphics** window toolbar, click  next to  **Select Objects**, then choose **Select Domains**.

9 On the object **fin**, select Domains 2 and 4 only.

10 Click the  **Wireframe Rendering** button in the **Graphics** toolbar.

## DEFINITIONS

#### *Step 1 (step1)*

1 In the **Definitions** toolbar, click  **More Functions** and choose **Step**.

2 In the **Settings** window for **Step**, click to expand the **Smoothing** section.

3 Locate the **Parameters** section. In the **Location** text field, type 0.05[s].

#### *Analytic 1 (an1)*

1 In the **Definitions** toolbar, click  **Analytic**.

- 2 In the **Settings** window for **Analytic**, locate the **Definition** section.
- 3 In the **Expression** text field, type  $\text{th\_max} * (\sin(2 * \pi * 1 * t) * (t < 0.25) * \text{step1}(t) + (t > 0.25))$ .
- 4 In the **Arguments** text field, type  $t$ .
- 5 Locate the **Units** section. In the table, enter the following settings:

Argument	Unit
$t$	s

- 6 In the **Function** text field, type  $\text{rad}$ .



#### *Variables I*

- 1 In the **Model Builder** window, right-click **Definitions** and choose **Variables**.
- 2 In the **Settings** window for **Variables**, locate the **Variables** section.
- 3 In the table, enter the following settings:

Name	Expression	Unit	Description
th	$\text{an1}(t)$	rad	Fin rotation
un_solid	$\text{fsip1.u\_solid} * (nX) + \text{fsip1.v\_solid} * (nY) + \text{fsip1.w\_solid} * (nZ)$	m	Normal mesh displacement, sliding boundary



#### *Identity Boundary Pair I (apI)*

You can group the interface boundaries by creating selections from the source and destination boundaries of the identity pairs. To identify the boundaries of each domain of the assembly, you can hide one of the domains and use selection highlights to see the boundaries of the unhidden domain.

- 1 In the **Model Builder** window, click **Identity Boundary Pair I (apI)**.
- 2 In the **Settings** window for **Pair**, locate the **Source Boundaries** section.
- 3 Click  **Create Selection**.
- 4 In the **Create Selection** dialog, type **Fluid Boundaries (Fins)** in the **Selection name** text field.
- 5 Click **OK**.
- 6 In the **Settings** window for **Pair**, locate the **Destination Boundaries** section.
- 7 Click  **Create Selection**.
- 8 In the **Create Selection** dialog, type **Solid Boundaries (Fins)** in the **Selection name** text field.

9 Click **OK**.

#### *Identity Boundary Pair 2 (ap2)*

- 1 In the **Model Builder** window, click **Identity Boundary Pair 2 (ap2)**.
- 2 In the **Settings** window for **Pair**, locate the **Source Boundaries** section.
- 3 Click  **Create Selection**.
- 4 In the **Create Selection** dialog, type Fluid Boundaries (Body) in the **Selection name** text field.
- 5 Click **OK**.
- 6 In the **Settings** window for **Pair**, locate the **Destination Boundaries** section.
- 7 Click  **Create Selection**.
- 8 In the **Create Selection** dialog, type Solid Boundaries (Body) in the **Selection name** text field.
- 9 Click **OK**.

#### *All Fluid Boundaries*

- 1 In the **Definitions** toolbar, click  **Union**.
- 2 In the **Settings** window for **Union**, type All Fluid Boundaries in the **Label** text field.
- 3 Locate the **Geometric Entity Level** section. From the **Level** list, choose **Boundary**.
- 4 Locate the **Input Entities** section. Under **Selections to add**, click **+ Add**.
- 5 In the **Add** dialog, in the **Selections to add** list, choose **Fluid Boundaries (Fins)** and **Fluid Boundaries (Body)**.
- 6 Click **OK**.

#### *Sliding Mesh Boundaries*

- 1 In the **Model Builder** window, right-click **Fluid Boundaries (Fins)** and choose **Duplicate**.
- 2 In the **Settings** window for **Explicit**, type Sliding Mesh Boundaries in the **Label** text field.
- 3 Locate the **Input Entities** section. Click  **Clear Selection**.
- 4 Select Boundaries 49, 50, 53–58, and 61–72 only.

Modify the domain selections and apply boundary conditions to the **Laminar Flow** and **Multibody Dynamics** interfaces.

#### **LAMINAR FLOW (SPF)**

- 1 In the **Model Builder** window, under **Component 1 (comp1)** click **Laminar Flow (spf)**.

- 2 In the **Settings** window for **Laminar Flow**, locate the **Domain Selection** section.
- 3 In the list, choose **5**, **6**, and **7**.
- 4 Click  **Remove from Selection**.
- 5 Select Domains 1–4 only.

*Wall 1*

- 1 In the **Model Builder** window, under **Component 1 (comp1)** > **Laminar Flow (spf)** click **Wall 1**.
- 2 In the **Settings** window for **Wall**, locate the **Boundary Condition** section.
- 3 From the **Wall condition** list, choose **Slip**.

*Pressure Point Constraint 1*

- 1 In the **Physics** toolbar, click  **Points** and choose **Pressure Point Constraint**.
- 2 Select Point 1 only.

**MULTIBODY DYNAMICS (MBD)**

- 1 In the **Model Builder** window, under **Component 1 (comp1)** click **Multibody Dynamics (mbd)**.
- 2 Select Domains 5–7 only.

*Rigid Material: Body*

- 1 In the **Physics** toolbar, click  **Domains** and choose **Rigid Material**.
- 2 In the **Settings** window for **Rigid Material**, type Rigid Material: Body in the **Label** text field.
- 3 Select Domain 7 only.

*Attachment: Fin 1*

- 1 In the **Physics** toolbar, click  **Boundaries** and choose **Attachment**.
- 2 In the **Settings** window for **Attachment**, type Attachment: Fin 1 in the **Label** text field.
- 3 Select Boundary 107 only.

*Attachment: Fin 2*

- 1 Right-click **Attachment: Fin 1** and choose **Duplicate**.
- 2 In the **Settings** window for **Attachment**, type Attachment: Fin 2 in the **Label** text field.
- 3 Locate the **Boundary Selection** section. Click  **Clear Selection**.
- 4 Select Boundary 108 only.

### Hinge Joint 1

- 1 In the **Physics** toolbar, click  **Global** and choose **Hinge Joint**.
- 2 In the **Settings** window for **Hinge Joint**, locate the **Attachment Selection** section.
- 3 From the **Source** list, choose **Rigid Material: Body**.
- 4 From the **Destination** list, choose **Attachment: Fin 1**.
- 5 Locate the **Center of Joint** section. From the list, choose **User defined**.
- 6 Locate the **Axis of Joint** section. Specify the  $\mathbf{e}_0$  vector as

0	x
0	y
1	z

### Prescribed Motion 1

- 1 In the **Physics** toolbar, click  **Attributes** and choose **Prescribed Motion**.
- 2 In the **Settings** window for **Prescribed Motion**, locate the **Prescribed Rotational Motion** section.
- 3 In the  $\theta_p$  text field, type  $-\text{th}$ .

### Hinge Joint 2

- 1 In the **Model Builder** window, under **Component 1 (comp1) > Multibody Dynamics (mbd)** right-click **Hinge Joint 1** and choose **Duplicate**.
- 2 In the **Settings** window for **Hinge Joint**, locate the **Attachment Selection** section.
- 3 From the **Destination** list, choose **Attachment: Fin 2**.

### Prescribed Motion 1

- 1 In the **Model Builder** window, expand the **Hinge Joint 2** node, then click **Prescribed Motion 1**.
- 2 In the **Settings** window for **Prescribed Motion**, locate the **Prescribed Rotational Motion** section.
- 3 In the  $\theta_p$  text field, type  $\text{th}$ .

Now you can add the moving mesh to the fluid domain.

## MOVING MESH

### Deforming Domain 1

- 1 In the **Model Builder** window, under **Component 1 (comp1) > Moving Mesh** click **Deforming Domain 1**.

2 Select Domains 1–4 only.

#### *Prescribed Mesh Displacement I*

- 1 In the **Moving Mesh** toolbar, click  **Prescribed Mesh Displacement**.
- 2 In the **Settings** window for **Prescribed Mesh Displacement**, locate the **Boundary Selection** section.
- 3 From the **Selection** list, choose **All Fluid Boundaries**.
- 4 Locate the **Prescribed Mesh Displacement** section. Specify the  $d_x$  vector as

fsip1.u_solid	X
fsip1.v_solid	Y
fsip1.w_solid	Z

#### *Prescribed Normal Mesh Displacement I*

- 1 In the **Moving Mesh** toolbar, click  **Prescribed Normal Mesh Displacement**.
- 2 In the **Settings** window for **Prescribed Normal Mesh Displacement**, locate the **Boundary Selection** section.
- 3 From the **Selection** list, choose **Sliding Mesh Boundaries**.
- 4 Locate the **Prescribed Normal Mesh Displacement** section. In the  $d_n$  text field, type un\_solid.
- 5 Click to expand the **Constraint Settings** section. From the **Constraint type** list, choose **Nitsche method**.

After assigning physics interfaces to all the domains, add materials to the domains.

#### **ADD MATERIAL**

- 1 In the **Materials** toolbar, click  **Add Material** to open the **Add Material** window.
- 2 Go to the **Add Material** window.
- 3 In the tree, select **Built-in > Water, liquid**.
- 4 Click the **Add to Component** button in the window toolbar.
- 5 In the tree, select **Built-in > Structural steel**.
- 6 Click the **Add to Component** button in the window toolbar.

#### **MATERIALS**

##### *Water, liquid (mat1)*

- 1 In the **Settings** window for **Material**, locate the **Geometric Entity Selection** section.

- 2 In the list, choose **5**, **6**, and **7**.
- 3 Click  **Remove from Selection**.
- 4 Select Domains 1–4 only.

#### *Structural steel (mat2)*

- 1 In the **Model Builder** window, click **Structural steel (mat2)**.
- 2 Select Domains 5–7 only.
- 3 In the **Materials** toolbar, click  **Add Material** to close the **Add Material** window.

#### **MESH 1**

In the **Model Builder** window, under **Component 1 (comp1)** right-click **Mesh 1** and choose **Edit Physics-Induced Sequence**.

#### *Size 3*

- 1 In the **Model Builder** window, under **Component 1 (comp1)** > **Mesh 1** click **Size 3**.
- 2 In the **Settings** window for **Size**, locate the **Geometric Entity Selection** section.
- 3 From the **Selection** list, choose **Solid Boundaries (Body)**.
- 4 Locate the **Element Size** section. Click the **Predefined** button.
- 5 From the **Predefined** list, choose **Fine**.
- 6 In the **Model Builder** window, right-click **Mesh 1** and choose **Build All**.

#### **MULTIPHYSICS**

You can choose the pairs on which fluid-structure interaction occurs.

#### *Fluid–Structure Interaction, Pair 1 (fsp1)*

- 1 In the **Model Builder** window, under **Component 1 (comp1)** > **Multiphysics** click **Fluid–Structure Interaction, Pair 1 (fsp1)**.
- 2 In the **Settings** window for **Fluid–Structure Interaction, Pair**, locate the **Pair Selection** section.
- 3 Click  **Add**.
- 4 In the **Add** dialog, in the **Pairs** list, choose **Identity Boundary Pair 1 (ap1)** and **Identity Boundary Pair 2 (ap2)**.
- 5 Click **OK**.

## STUDY I

### Step 1: Time Dependent

- 1 In the **Model Builder** window, under **Study I** click **Step 1: Time Dependent**.
- 2 In the **Settings** window for **Time Dependent**, locate the **Study Settings** section.
- 3 In the **Output times** text field, type range (0,0.01,0.3) range (0.32,0.02,1).
- 4 From the **Tolerance** list, choose **User controlled**.
- 5 In the **Relative tolerance** text field, type 0.005.

### Solution 1 (sol1)

- 1 In the **Study** toolbar, click  **Show Default Solver**.
- 2 In the **Model Builder** window, expand the **Solution 1 (sol1)** node, then click **Time-Dependent Solver 1**.
- 3 In the **Settings** window for **Time-Dependent Solver**, click to expand the **Time Stepping** section.
- 4 From the **Steps taken by solver** list, choose **Intermediate**.
- 5 Find the **Algebraic variable settings** subsection. In the **Fraction of initial step for Backward Euler** text field, type 0.01.
- 6 In the **Model Builder** window, expand the **Study I > Solver Configurations > Solution 1 (sol1) > Time-Dependent Solver 1 > Segregated 1** node, then click **Merged Variables**.
- 7 In the **Settings** window for **Segregated Step**, click to expand the **Method and Termination** section.
- 8 From the **Jacobian update** list, choose **On every iteration**.

### Step 1: Time Dependent

- 1 In the **Model Builder** window, under **Study I** right-click **Step 1: Time Dependent** and choose **Get Initial Value for Step**.
- 2 In the **Settings** window for **Time Dependent**, click to expand the **Results While Solving** section.
- 3 Select the **Plot** checkbox.
- 4 In the table, enter the following settings:

Plot group	Plot window
Displacement (mbd)	Graphics

- 5 In the **Study** toolbar, click  **Compute**.

## RESULTS

### *Velocity (spf)*

- 1 In the **Settings** window for **3D Plot Group**, locate the **Data** section.
- 2 From the **Time (s)** list, choose **1**.
- 3 In the **Velocity (spf)** toolbar, click  **Plot**.

### *Pressure (spf)*

- 1 In the **Model Builder** window, click **Pressure (spf)**.
- 2 In the **Settings** window for **3D Plot Group**, locate the **Data** section.
- 3 From the **Time (s)** list, choose **1**.
- 4 In the **Pressure (spf)** toolbar, click  **Plot**.

### *Velocity (mbd)*

- 1 In the **Model Builder** window, click **Velocity (mbd)**.
- 2 In the **Settings** window for **3D Plot Group**, locate the **Data** section.
- 3 From the **Time (s)** list, choose **1**.

### *Arrow Line*

- 1 In the **Model Builder** window, expand the **Velocity (mbd)** node, then click **Arrow Line**.
- 2 In the **Settings** window for **Arrow Line**, locate the **Coloring and Style** section.
- 3 Select the **Scale factor** checkbox. In the associated text field, type **35**.
- 4 Locate the **Arrow Positioning** section. From the **Placement** list, choose **Uniform**.
- 5 In the **Number of arrows** text field, type **4000**.
- 6 Locate the **Coloring and Style** section. From the **Color** list, choose **Cyan**.
- 7 In the **Velocity (mbd)** toolbar, click  **Plot**.

### *Displacement (mbd), Moving Mesh, Pressure (spf), Velocity (mbd), Velocity (spf)*

- 1 In the **Model Builder** window, under **Results**, Ctrl-click to select **Velocity (spf)**, **Pressure (spf)**, **Displacement (mbd)**, **Velocity (mbd)**, and **Moving Mesh**.
- 2 Right-click and choose **Group**.

### *Default Plots*

In the **Settings** window for **Group**, type **Default Plots** in the **Label** text field.

For better visualization of the results, you can also set a new view of the assembly.

### *Fluid Pressure (xy) & Solid Displacement*

Follow the instructions below to plot the fluid velocity and pressure fields in the  $xy$ -plane as well as the displacement and velocity of the mechanism. Compare the resulting plot with the one shown in [Figure 4](#).

- 1 In the **Results** toolbar, click  **3D Plot Group**.
- 2 In the **Settings** window for **3D Plot Group**, type Fluid Pressure (xy) & Solid Displacement in the **Label** text field.
- 3 Locate the **Data** section. From the **Time (s)** list, choose **0.3**.
- 4 Locate the **Plot Settings** section. From the **Frame** list, choose **Spatial (x, y, z)**.

### *Solid Displacement*

- 1 Right-click **Fluid Pressure (xy) & Solid Displacement** and choose **Surface**.
- 2 In the **Settings** window for **Surface**, type Solid Displacement in the **Label** text field.
- 3 Click **Replace Expression** in the upper-right corner of the **Expression** section. From the menu, choose **Component 1 (comp1) > Multibody Dynamics > Displacement > mbd.disp - Displacement magnitude - m**.
- 4 Click to expand the **Range** section. Select the **Manual color range** checkbox.
- 5 In the **Maximum** text field, type 1.6.
- 6 Locate the **Coloring and Style** section. From the **Color table** list, choose **Twilight**.

### *Pressure*

- 1 Right-click **Solid Displacement** and choose **Duplicate**.
- 2 In the **Settings** window for **Surface**, type Pressure in the **Label** text field.
- 3 Click **Replace Expression** in the upper-right corner of the **Expression** section. From the menu, choose **Component 1 (comp1) > Laminar Flow > Velocity and pressure > p - Pressure - Pa**.
- 4 Locate the **Range** section. In the **Minimum** text field, type -1.
- 5 In the **Maximum** text field, type 1.
- 6 Locate the **Coloring and Style** section. From the **Color table** list, choose **Rainbow**.

### *Selection 1*

- 1 Right-click **Pressure** and choose **Selection**.
- 2 Select Boundaries 6 and 13 only.

### *Pressure Contour*

- 1 In the **Model Builder** window, right-click **Fluid Pressure (xy) & Solid Displacement** and choose **Contour**.
- 2 In the **Settings** window for **Contour**, type Pressure Contour in the **Label** text field.
- 3 Click **Replace Expression** in the upper-right corner of the **Expression** section. From the menu, choose **Component 1 (comp1) > Laminar Flow > Velocity and pressure > p - Pressure - Pa**.
- 4 Click to expand the **Title** section. From the **Title type** list, choose **None**.
- 5 Locate the **Coloring and Style** section. From the **Coloring** list, choose **Uniform**.
- 6 From the **Color** list, choose **White**.
- 7 Clear the **Color legend** checkbox.

### *Selection 1*

- 1 Right-click **Pressure Contour** and choose **Selection**.
- 2 Select Boundaries 6 and 13 only.

### *Fluid Velocity*

- 1 In the **Model Builder** window, right-click **Fluid Pressure (xy) & Solid Displacement** and choose **Arrow Surface**.
- 2 In the **Settings** window for **Arrow Surface**, type Fluid Velocity in the **Label** text field.
- 3 Locate the **Coloring and Style** section.
- 4 Select the **Scale factor** checkbox. In the associated text field, type 20.
- 5 Locate the **Arrow Positioning** section. In the **Number of arrows** text field, type 4000.

### *Selection 1*

- 1 Right-click **Fluid Velocity** and choose **Selection**.
- 2 Select Boundaries 6 and 13 only.

### *Solid Velocity*

- 1 In the **Model Builder** window, right-click **Fluid Pressure (xy) & Solid Displacement** and choose **Arrow Line**.
- 2 In the **Settings** window for **Arrow Line**, type Solid Velocity in the **Label** text field.
- 3 Click **Replace Expression** in the upper-right corner of the **Expression** section. From the menu, choose **Component 1 (comp1) > Multibody Dynamics > Acceleration and velocity > mbd.u\_tX,mbd.u\_tY,mbd.u\_tZ - Velocity**.
- 4 Locate the **Coloring and Style** section.

- 5 Select the **Scale factor** checkbox. In the associated text field, type 35.
- 6 Locate the **Arrow Positioning** section. In the **Number of arrows** text field, type 50.
- 7 Locate the **Coloring and Style** section. From the **Color** list, choose **Magenta**.

#### *Selection I*



- 1 Right-click **Solid Velocity** and choose **Selection**.
- 2 Select Edges 185, 188, 228, 249, 256, 261, 266, and 269 only.
- 3 In the **Fluid Pressure (xy) & Solid Displacement** toolbar, click  **Plot**.

#### *Fluid Pressure (xz) & Solid Displacement*



Follow the instructions below to plot the fluid velocity and pressure fields in the  $xz$ -plane as well as the displacement and velocity of the mechanism. Compare the resulting plot with the one shown in [Figure 5](#).

- 1 In the **Model Builder** window, right-click **Fluid Pressure (xy) & Solid Displacement** and choose **Duplicate**.
- 2 In the **Settings** window for **3D Plot Group**, type Fluid Pressure (xz) & Solid Displacement in the **Label** text field.
- 3 In the **Model Builder** window, expand the **Fluid Pressure (xz) & Solid Displacement** node.

#### *Selection I*

- 1 In the **Model Builder** window, expand the **Results** > **Fluid Pressure (xz) & Solid Displacement** > **Pressure** node, then click **Selection I**.
- 2 In the **Settings** window for **Selection**, locate the **Selection** section.
- 3 Click  **Clear Selection**.
- 4 Click  **Paste Selection**.
- 5 In the **Paste Selection** dialog, type 9 12 in the **Selection** text field.
- 6 Click **OK**.



#### *Selection I*

- 1 In the **Model Builder** window, expand the **Results** > **Fluid Pressure (xz) & Solid Displacement** > **Pressure Contour** node, then click **Selection I**.
- 2 In the **Settings** window for **Selection**, locate the **Selection** section.
- 3 Click  **Clear Selection**.
- 4 Click  **Paste Selection**.
- 5 In the **Paste Selection** dialog, type 9 12 in the **Selection** text field.
- 6 Click **OK**.

### Fluid Velocity

- 1 In the **Model Builder** window, under **Results > Fluid Pressure (xz) & Solid Displacement** click **Fluid Velocity**.
- 2 In the **Settings** window for **Arrow Surface**, locate the **Coloring and Style** section.
- 3 In the **Scale factor** text field, type 100.

### Selection 1

- 1 In the **Model Builder** window, expand the **Fluid Velocity** node, then click **Selection 1**.
- 2 In the **Settings** window for **Selection**, locate the **Selection** section.
- 3 Click  **Clear Selection**.
- 4 Click  **Paste Selection**.
- 5 In the **Paste Selection** dialog, type 9 12 in the **Selection** text field.
- 6 Click **OK**.
- 7 In the **Fluid Pressure (xz) & Solid Displacement** toolbar, click  **Plot**.

Follow the instructions below to plot the deformed mesh. The resulting plot should match the one shown in [Figure 6](#).

### Deformed Mesh

- 1 In the **Results** toolbar, click  **3D Plot Group**.
- 2 In the **Settings** window for **3D Plot Group**, type Deformed Mesh in the **Label** text field.
- 3 Locate the **Plot Settings** section. From the **Frame** list, choose **Spatial (x, y, z)**.

### Mesh 1

- 1 Right-click **Deformed Mesh** and choose **Mesh**.
- 2 In the **Settings** window for **Mesh**, locate the **Level** section.
- 3 From the **Level** list, choose **Volume**.
- 4 Locate the **Coloring and Style** section. From the **Element color** list, choose **Gray**.
- 5 In the **Deformed Mesh** toolbar, click  **Plot**.

### Deformed Mesh

Follow the instructions below to plot the fin rotations and forward velocity of the structure. The resulting plot should match the one shown in [Figure 7](#).

### ID Plot Group 9

- In the **Results** toolbar, click  **ID Plot Group**.

### *Fin Rotation*

- 1 Right-click **ID Plot Group 9** and choose **Global**.
- 2 In the **Settings** window for **Global**, type **Fin Rotation** in the **Label** text field.
- 3 Locate the **y-Axis Data** section. In the table, enter the following settings:

Expression	Unit	Description
$th \cdot 180 / \pi$	rad	Fin Rotation

### *Fin Rotation I*

Right-click **Fin Rotation** and choose **Duplicate**.

### *Forward Velocity*

- 1 In the **Model Builder** window, expand the **Results > ID Plot Group 9 > Fin Rotation** node, then click **Results > ID Plot Group 9 > Fin Rotation I**.
- 2 In the **Settings** window for **Global**, type **Forward Velocity** in the **Label** text field.
- 3 Locate the **y-Axis Data** section. In the table, enter the following settings:

Expression	Unit	Description
<code>mbd.rd1.u_tx</code>	cm/s	Forward Velocity

- 4 Click to expand the **Coloring and Style** section. Find the **Line style** subsection. From the **Line** list, choose **Dashed**.

### *Fin Rotation & Velocity*

- 1 In the **Model Builder** window, under **Results** click **ID Plot Group 9**.
- 2 In the **Settings** window for **ID Plot Group**, type **Fin Rotation & Velocity** in the **Label** text field.
- 3 Locate the **Plot Settings** section.
- 4 Select the **y-axis label** checkbox. In the associated text field, type **Fin Rotation (deg)**.
- 5 Select the **Two y-axes** checkbox.
- 6 In the table, select the **Plot on secondary y-axis** checkbox for **Forward Velocity**.

### *Fluid Pressure (xy) & Solid Displacement*

- 1 In the **Results** toolbar, click  **Animation** and choose **Player**.
- 2 In the **Settings** window for **Animation**, type **Fluid Pressure (xy) & Solid Displacement** in the **Label** text field.
- 3 Locate the **Scene** section. From the **Subject** list, choose **Fluid Pressure (xy) & Solid Displacement**.

### *Fluid Pressure (xz) & Solid Displacement*

- 1 Right-click **Fluid Pressure (xy) & Solid Displacement** and choose **Duplicate**.
- 2 In the **Settings** window for **Animation**, type Fluid Pressure (xz) & Solid Displacement in the **Label** text field.
- 3 Locate the **Scene** section. From the **Subject** list, choose **Fluid Pressure (xz) & Solid Displacement**.

### *Deformed Mesh*

- 1 Right-click **Fluid Pressure (xz) & Solid Displacement** and choose **Duplicate**.
- 2 In the **Settings** window for **Animation**, type Deformed Mesh in the **Label** text field.
- 3 Locate the **Scene** section. From the **Subject** list, choose **Deformed Mesh**.