



Model created in COMSOL Multiphysics 6.4

Modeling Vibration in an Induction Motor

Introduction

This model simulates the electromechanical effects in a three phase induction motor. The assembly consists of stator, rotor and housing. In this example, the eddy currents are induced in the rotor by the time harmonic currents on the stator windings and the rotor's rotation. The air gap between the rotor and stator is assumed asymmetric and the resulting vibrations in the motor are analyzed.

The electromagnetic simulation of an induction motor is performed in 2D whereas the multibody dynamics simulation is performed in 3D. The rotational torque, when an alternating current is passed through the stator windings, is calculated as a function of time. It is used in the multibody dynamics model in order to compute the angular speed of the rotor.

Note: This model requires the AC/DC Module and the Multibody Dynamics Module.

Model Definition

The three phase induction motor-housing assembly is shown in [Figure 1](#).

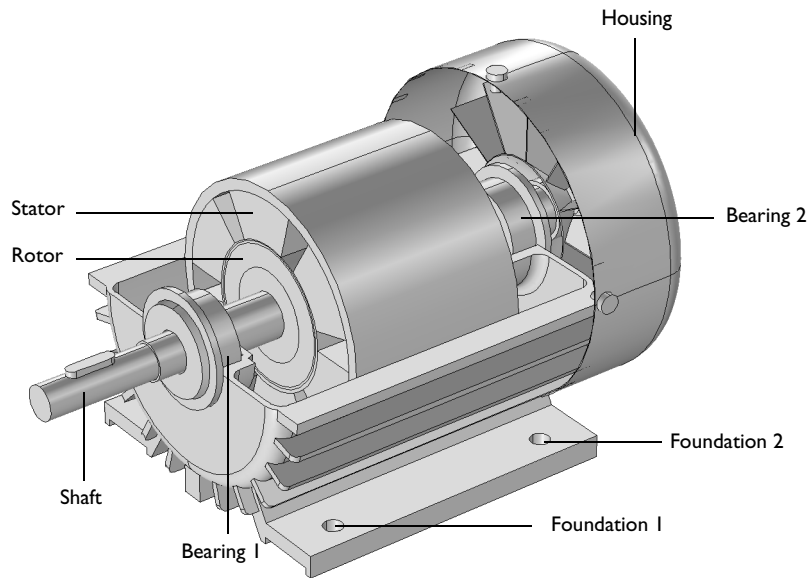

Figure 1: The geometry of a three phase induction motor-housing assembly.

The induction motor modeled in this example has the following parts:

- Stator
- Rotor
- Shaft
- Housing
- Bearings
- Foundation

All parts, except the bearings and foundation, are physically modeled. The latter are modeled as massless springs.

The model uses two different physics interfaces:

- Rotating Machinery, Magnetic interface to simulate the electromagnetic fields in the motor.
- Multibody Dynamics interface to simulate the motion of the rotor and vibration in the housing.

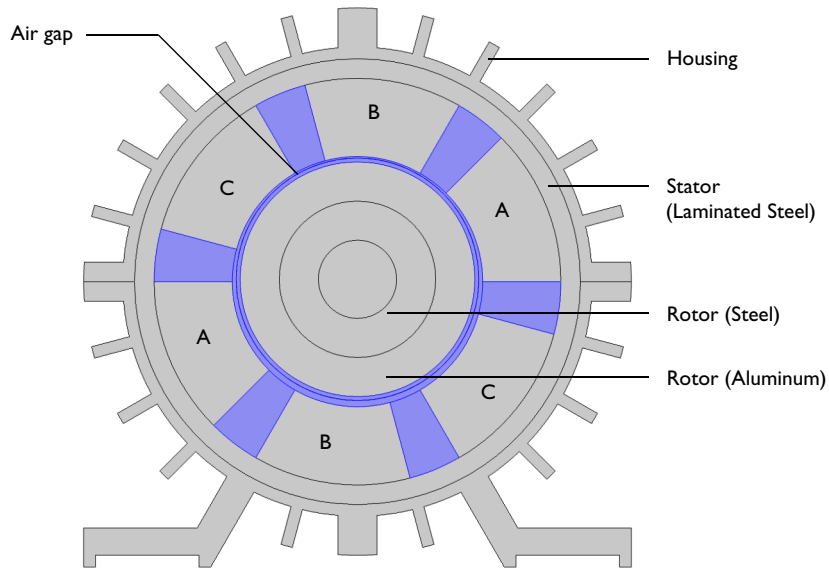

Figure 2: Cross sectional view of three phase induction motor showing stator, rotor, and the housing. The figure shows three different coil regions A, B, and C in the stator representing three phases of the motor. The air gap between the stator and rotor is also highlighted.

ELECTROMAGNETIC MODEL DESCRIPTION

The electromagnetic field equations are solved in a transverse section of the induction motor as shown in [Figure 2](#). In the electromagnetic simulation, only the following parts are considered:

- Stator
- Rotor
- Air gap

The stator is made of steel. The stator steel is laminated and its conductivity is zero. The inner part of the rotor is made of steel and outer part is made of aluminum and they have the conductivity of 1.6×10^6 S/m and 3.74×10^7 S/m respectively. There exists a slight misalignment between the rotor and stator, making the air gap asymmetric.

Each of the three phases of the stator winding spans 45 degrees and they are separated by 120 electrical degrees. The alternating current (60 Hz) through the stator windings is applied using a homogenized multiturn coil feature with 2045 turns. The geometrical

dimensions for this model are obtained from [Ref. 1](#). More details about the electromagnetic model can be found in [Ref. 2](#).

MULTIBODY DYNAMICS MODEL DESCRIPTION

In the multibody dynamics model, the stator, rotor, and shaft are considered to be rigid. The rotor is rigidly mounted on the shaft. The bearings are modeled by elastic hinge joints between the rotor and housing. The bearings are responsible for supporting the rotor and in turn transmitting the forces to the housing. The housing is assumed elastic and made of structural steel. The housing is supported on the foundation using elastic fixed joints. The bearing and foundation stiffness parameters are given in [Table 1](#) below.

TABLE 1: BEARING AND FOUNDATION PARAMETERS.

Parameter	Value
Bearing translational stiffness (k_b)	1×10^6 N/m
Bearing rotational stiffness (k_{br})	1×10^4 Nm/rad
Foundation translational stiffness (k_f)	1×10^6 N/m
Foundation rotational stiffness (k_{fr})	1×10^4 Nm/rad

ELECTROMAGNETIC-MULTIBODY DYNAMICS COUPLING

Electromagnetic Torque

The electromagnetic torque calculated in the Rotating Machinery, Magnetic interface is applied on the rotor as well as on the stator in the Multibody Dynamics interface. As the rotor is free to rotate about its own axis, it starts accelerating by overcoming the inertial resistance. The reaction torque on the stator bends the motor-housing assembly in the direction opposite to the rotor rotation.

Rotor Speed

The rotor speed calculated using the angular motion of the hinge joint in the Multibody Dynamics interface is transferred to the Rotating Machinery, Magnetic interface.

Electromagnetic Forces

In addition to the above, the misalignment between the stator and rotor also causes nonzero resultant electromagnetic forces. These forces calculated in the Rotating Machinery, Magnetic interface are also applied to the rotor and stator in the Multibody Dynamics interface. Since these forces are oscillating in nature, they cause vibrations in the motor.

Results and Discussion

A transient analysis is performed to calculate the torque, speed, and vibration in an induction motor. The magnetic flux density norm in the rotor and stator coils at a particular instant is shown in [Figure 3](#).

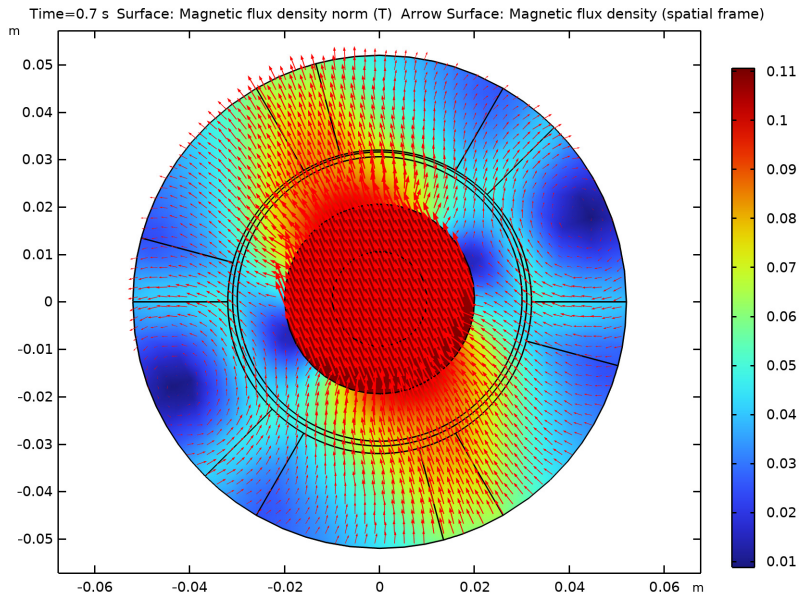

Figure 3: Magnetic flux density in the rotor and stator at $t = 0.7$ s.

The von Mises stress distribution in the housing together with the velocity of the rotor is shown in [Figure 4](#). It can be seen that the stress values are higher near the bearing and at the connection between the housing and the foundation.

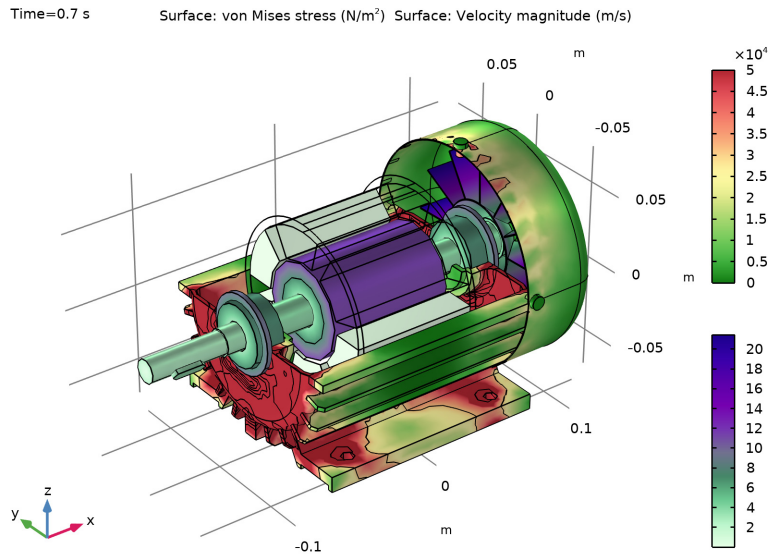

Figure 4: von Mises stress distribution in the housing and the rotor velocity profile at $t = 0.7$ s.

[Figure 5](#) illustrates the electromagnetic torque as a function of time. It can be seen that in the absence of any loading torque on the shaft, the electromagnetic torque goes to zero as the rotor achieves the speed equal to the stator electrical frequency (60 Hz).

The angular speed of the rotor as a function of time is shown in [Figure 6](#). It can be seen that it takes 0.7 seconds for the rotor to reach the steady state speed. The time delay for the rotor speed to reach the stator electrical frequency depends on the inertia of the rotor.

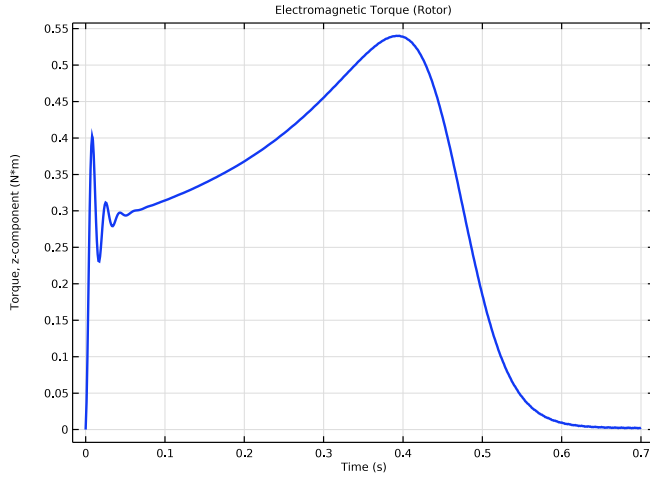

Figure 5: Electromagnetic torque in the rotor as a function of time.

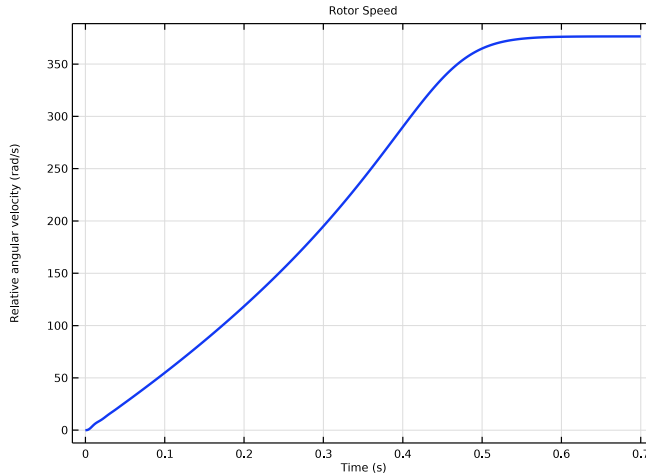

Figure 6: Rotor angular speed as a function of time.

Figure 7 shows the electromagnetic forces experienced by the rotor as a function of time. These vibrating forces in the transverse direction of the rotor are caused by the misalignment between the stator and rotor.

The frequency spectrum of electromagnetic forces can be seen in [Figure 8](#). It is clear that the frequency of these forces is 120 Hz which is twice the stator electrical frequency.

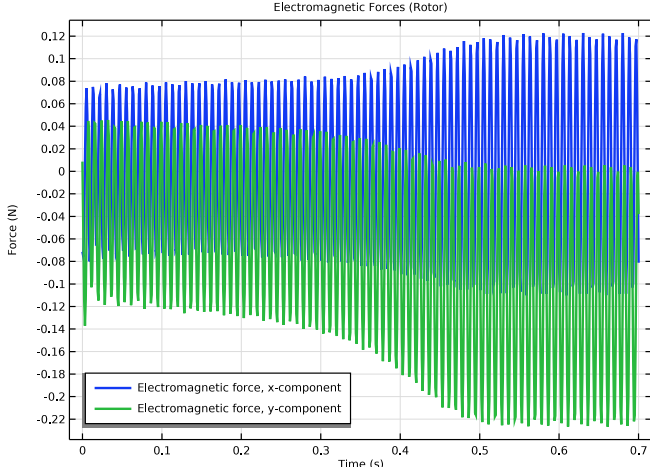

Figure 7: Electromagnetic forces in the rotor in transverse and axial directions.

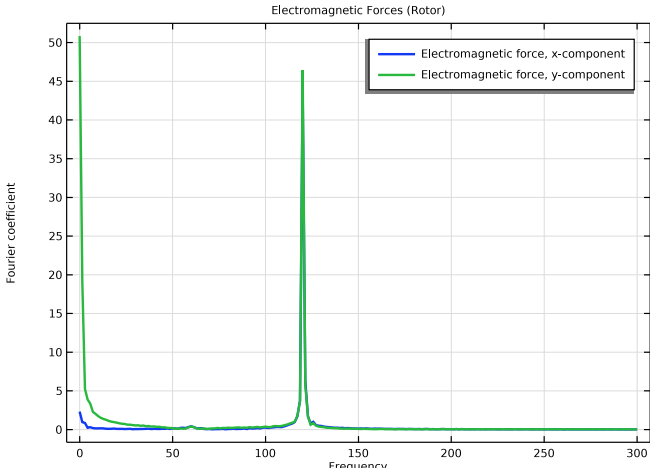

Figure 8: Frequency spectrum of electromagnetic forces in the rotor.

The forces experienced by the bearings on both sides as a function of time are shown in [Figure 9](#) and [Figure 10](#). These forces are transmitted to the foundation through elastic housing. The foundation forces as a function of time at one of the locations are shown in [Figure 11](#). The frequency spectrum of the same forces can be seen in [Figure 12](#).

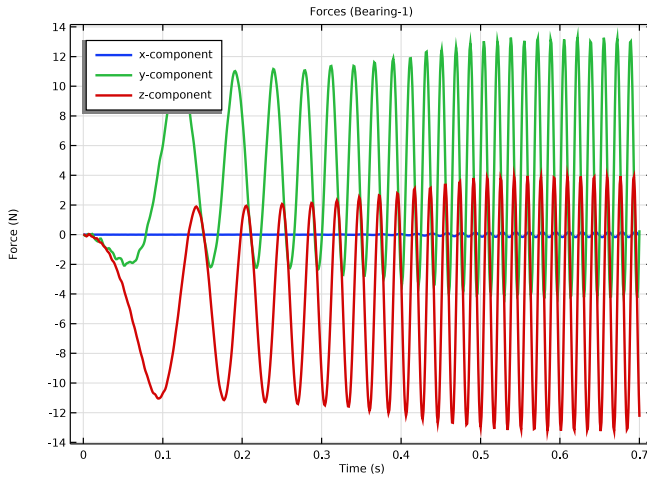

Figure 9: Forces in bearing-1 in transverse and axial directions.

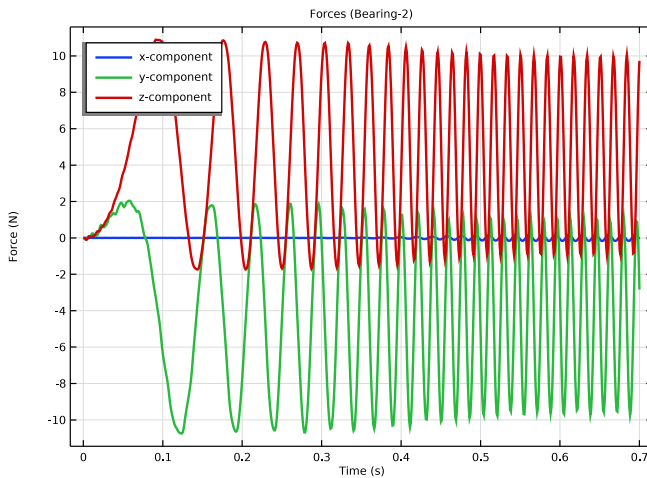

Figure 10: Forces in bearing-2 in transverse and axial directions.

Note that the dominant frequency contribution is centered around 60 Hz in spite of the electromagnetic forces having a frequency of 120 Hz. Small peaks can also be seen around 83 Hz which is the first natural frequency of the induction motor-housing assembly.

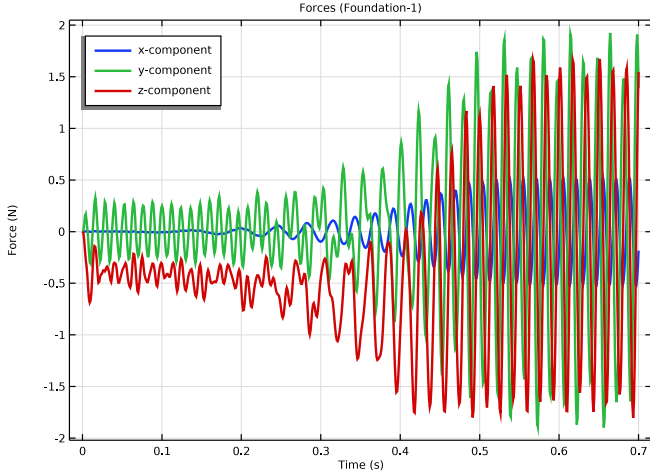

Figure 11: Forces in the housing-foundation connection at one of the locations.

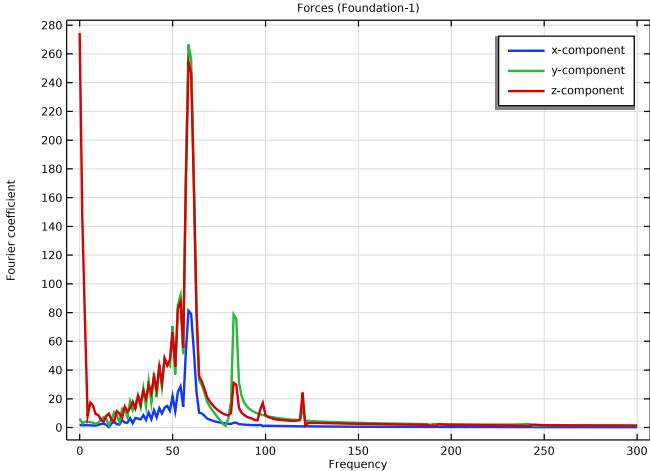

Figure 12: Frequency spectrum of forces in the housing-foundation connection.

As the electromagnetic forces are acting on the rotor in the transverse direction, and the bearings supporting the rotor at the ends have finite stiffness, rotor starts vibrating in the transverse direction with respect to the stator. This orbital motion, a combination of rotation and vibration, of the rotor at both the bearing locations is shown in [Figure 13](#). Note that the orbits are not concentric because of the asymmetry in the inertia of the rotor in the axial direction.

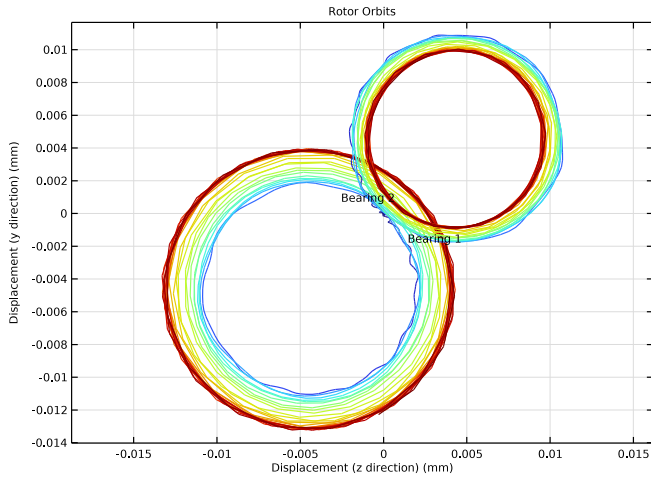

Figure 13: Orbital motion of the rotor at bearing locations.

Notes About the COMSOL Implementation

- The 2D geometry of the induction motor is the cross section of the 3D geometry. The length of the 2D geometry in the out-of-plane direction in the Rotating Machinery, Magnetic interface is set to the length of the rotor in the 3D geometry.
- The 2D geometry has stationary and rotating domains. As it is finalized with the assembly option, an identity pair forms automatically between the stationary and rotating domains.
- For faster computation, linear shape functions are used instead of the default quadratic shape functions for the magnetic vector potential.
- Some parts having comparatively higher structural stiffness are modeled as rigid elements using the **Rigid Material** model. The remaining parts are assumed flexible and modeled using **Linear Elastic Material**.

References

1. K. Davey, “Induction Motor Analysis: International TEAM Workshop Problem 30,” www.compumag.org/jsite/images/stories/TEAM/problem30a.pdf.
2. COMSOL Application Gallery, *Induction Motor in 2D*, www.comsol.com/model/induction-motor-in-2d-14487.

Application Library path: Multibody_Dynamics_Module/Electrical_Machinery/induction_motor_vibration/



Modeling Instructions

From the **File** menu, choose **New**.

NEW

In the **New** window, click  **Model Wizard**.

MODEL WIZARD

- 1 In the **Model Wizard** window, click  **2D**.
- 2 In the **Select Physics** tree, select **AC/DC** > **Electromagnetics and Mechanics** > **Rotating Machinery, Magnetic (rmm)**.
- 3 Click **Add**.
- 4 Click  **Study**.
- 5 In the **Select Study** tree, select **General Studies** > **Time Dependent**.
- 6 Click  **Done**.

GLOBAL DEFINITIONS

Parameters 1

- 1 In the **Model Builder** window, under **Global Definitions** click **Parameters 1**.
- 2 In the **Settings** window for **Parameters**, locate the **Parameters** section.
- 3 Click  **Load from File**.
- 4 Browse to the model’s Application Libraries folder and double-click the file `induction_motor_vibration_parameters.txt`.



Import the 3D geometry of an induction motor in a 3D **Component** and then create 2D geometry using **Cross Section** functionality.

ADD COMPONENT

In the **Model Builder** window, right-click the root node and choose **Add Component > 3D**.

GEOMETRY 2

Import 1 (imp1)

- 1 In the **Geometry** toolbar, click  **Import**.
- 2 In the **Settings** window for **Import**, locate the **Source** section.
- 3 Click  **Browse**.
- 4 Browse to the model's Application Libraries folder and double-click the file `induction_motor_vibration.mphbin`.

Work Plane 1 (wp1)

- 1 In the **Geometry** toolbar, click  **Work Plane**.
- 2 In the **Settings** window for **Work Plane**, locate the **Plane Definition** section.
- 3 From the **Plane** list, choose **yz-plane**.

Form Union (fin)

- 1 In the **Model Builder** window, under **Component 2 (comp2) > Geometry 2** click **Form Union (fin)**.
- 2 In the **Settings** window for **Form Union/Assembly**, locate the **Form Union/Assembly** section.
- 3 From the **Action** list, choose **Form an assembly**.
- 4 Clear the **Create pairs** checkbox.
- 5 In the **Geometry** toolbar, click  **Build All**.

GEOMETRY 1

In the **Model Builder** window, under **Component 1 (comp1)** click **Geometry 1**.

Cross Section 1 (crol)

In the **Geometry** toolbar, click  **Cross Section**.

Form Union (fin)

- 1 In the **Model Builder** window, under **Component 1 (comp1) > Geometry 1** click **Form Union (fin)**.
- 2 In the **Settings** window for **Form Union/Assembly**, locate the **Form Union/Assembly** section.

- 3 From the **Action** list, choose **Form an assembly**.
- 4 In the **Geometry** toolbar, click  **Build All**.

DEFINITIONS (COMPI)

Disable the analysis of the geometry as the remaining small geometric details can be kept.

GEOMETRY 2

- 1 In the **Model Builder** window, expand the **Component 1 (comp1) > Definitions** node, then click **Component 2 (comp2) > Geometry 2**.
- 2 In the **Settings** window for **Geometry**, locate the **Cleanup** section.
- 3 Clear the **Automatic detection of small details** checkbox.

DEFINITIONS (COMPI)



Variables 1

- 1 In the **Model Builder** window, under **Component 1 (comp1)** right-click **Definitions** and choose **Variables**.
- 2 In the **Settings** window for **Variables**, locate the **Variables** section.
- 3 In the table, enter the following settings:

Name	Expression	Unit	Description
Ia	$1[A]*\sqrt{2}*\cos(w0*t)$	A	Current on phase A
Ib	$1[A]*\sqrt{2}*\cos(w0*t+120[deg])$	A	Current on phase B
Ic	$1[A]*\sqrt{2}*\cos(w0*t-120[deg])$	A	Current on phase C

Assign materials to the different parts of the motor.

ADD MATERIAL

- 1 In the **Materials** toolbar, click  **Add Material** to open the **Add Material** window.
- 2 Go to the **Add Material** window.
- 3 In the tree, select **Built-in > Air**.
- 4 Click the **Add to Component** button in the window toolbar.
- 5 In the tree, select **Built-in > Aluminum**.
- 6 Click the **Add to Component** button in the window toolbar.
- 7 In the **Materials** toolbar, click  **Add Material** to close the **Add Material** window.

MATERIALS

Aluminum (mat2)

Select Domain 18 only.

Steel: Rotor

- 1 In the **Model Builder** window, right-click **Materials** and choose **Blank Material**.
- 2 In the **Settings** window for **Material**, type Steel: Rotor in the **Label** text field.
- 3 Select Domains 19 and 20 only.
- 4 Locate the **Material Contents** section. In the table, enter the following settings:

Property	Variable	Value	Unit	Property group
Relative permeability	mur	30		Basic
Electric conductivity	sigma	1.6e6[S/m]	S/m	Basic
Relative permittivity	epsilon	1		Basic

Steel: Stator

- 1 Right-click **Steel: Rotor** and choose **Duplicate**.
- 2 In the **Settings** window for **Material**, type Steel: Stator in the **Label** text field.
- 3 Locate the **Geometric Entity Selection** section. Click  **Clear Selection**.
- 4 Select Domain 3 only.
- 5 Locate the **Material Contents** section. In the table, enter the following settings:

Property	Variable	Value	Unit	Property group
Relative permeability	mur	30		Basic
Electric conductivity	sigma	0[S/m]	S/m	Basic
Relative permittivity	epsilon	1		Basic

ROTATING MACHINERY, MAGNETIC (RMM)

- 1 In the **Model Builder** window, under **Component 1 (comp1)** click **Rotating Machinery, Magnetic (rmm)**.
- 2 Select Domains 3–20 only.
- 3 In the **Settings** window for **Rotating Machinery, Magnetic**, locate the **Thickness** section.
- 4 In the d text field, type L.

5 Click to expand the **Discretization** section. From the **Magnetic vector potential** list, choose **Linear**.

6 From the **Magnetic scalar potential** list, choose **Quadratic**.

Coil: Phase A

1 In the **Physics** toolbar, click  **Domains** and choose **Domain Coil**.

2 In the **Settings** window for **Domain Coil**, type Coil: Phase A in the **Label** text field.

3 Select Domains 5 and 15 only.

4 Locate the **Coil** section. From the **Conductor model** list, choose **Homogenized multiturn**.

5 Select the **Coil group** checkbox.

6 In the I_{coil} text field, type Ia.

7 Locate the **Homogenized Conductor** section. In the N text field, type n0.

8 From the list, choose **User defined**.

9 Find the **High-frequency effective loss** subsection. Clear the **Include harmonic loss** checkbox.

Reversed Current Direction I

1 In the **Physics** toolbar, click  **Attributes** and choose **Reversed Current Direction**.

2 Select Domain 15 only.

Coil: Phase B

1 In the **Model Builder** window, right-click **Coil: Phase A** and choose **Duplicate**.

2 In the **Settings** window for **Domain Coil**, type Coil: Phase B in the **Label** text field.

3 Locate the **Domain Selection** section. Click  **Clear Selection**.

4 Select Domains 9 and 11 only.

5 Locate the **Coil** section. In the I_{coil} text field, type Ib.

Reversed Current Direction I

1 In the **Model Builder** window, expand the **Coil: Phase B** node, then click **Reversed Current Direction I**.

2 In the **Settings** window for **Reversed Current Direction**, locate the **Domain Selection** section.

3 Click  **Clear Selection**.

4 Select Domain 9 only.

Coil: Phase C

1 In the **Model Builder** window, right-click **Coil: Phase B** and choose **Duplicate**.

- 2 In the **Settings** window for **Domain Coil**, type Coil: Phase C in the **Label** text field.
- 3 Locate the **Domain Selection** section. Click  **Clear Selection**.
- 4 Select Domains 6 and 13 only.
- 5 Locate the **Coil** section. In the I_{coil} text field, type Ic.

Reversed Current Direction I

- 1 In the **Model Builder** window, expand the **Coil: Phase C** node, then click **Reversed Current Direction I**.
- 2 In the **Settings** window for **Reversed Current Direction**, locate the **Domain Selection** section.
- 3 Click  **Clear Selection**.
- 4 Select Domain 6 only.

Magnetic Continuity Ia

- 1 In the **Physics** toolbar, click  **Pairs** and choose **Magnetic Continuity**.
- 2 In the **Settings** window for **Magnetic Continuity**, locate the **Pair Selection** section.
- 3 Click **+** **Add**.
- 4 In the **Add** dialog, select **Identity Boundary Pair I (ap1)** in the **Pairs** list.
- 5 Click **OK**.

Force Calculation: Rotor

- 1 In the **Physics** toolbar, click  **Domains** and choose **Force Calculation**.
- 2 In the **Settings** window for **Force Calculation**, type Force Calculation: Rotor in the **Label** text field.
- 3 Locate the **Force Calculation** section. In the **Force name** text field, type Rotor.
- 4 Specify the \mathbf{r}_0 vector as

0	x
dy	y

- 5 Select Domains 18–20 only.

Force Calculation: Stator

- 1 Right-click **Force Calculation: Rotor** and choose **Duplicate**.
- 2 In the **Settings** window for **Force Calculation**, type Force Calculation: Stator in the **Label** text field.
- 3 Locate the **Force Calculation** section. In the **Force name** text field, type Stator.

4 Specify the \mathbf{r}_0 vector as

0	x
0	y

5 Locate the **Domain Selection** section. Click  **Clear Selection**.

6 Select Domains 3–7 and 9–16 only.

MESH 1

1 In the **Model Builder** window, under **Component 1 (comp1)** click **Mesh 1**.

2 In the **Settings** window for **Mesh**, locate the **Sequence Type** section.

3 From the list, choose **User-controlled mesh**.

Size

1 In the **Model Builder** window, under **Component 1 (comp1)** > **Mesh 1** click **Size**.

2 In the **Settings** window for **Size**, locate the **Element Size** section.

3 From the **Predefined** list, choose **Extra coarse**.

Size 1

1 In the **Model Builder** window, right-click **Free Triangular 1** and choose **Size**.

2 In the **Settings** window for **Size**, locate the **Geometric Entity Selection** section.

3 From the **Geometric entity level** list, choose **Domain**.

4 Select Domains 18–20 only.

5 Locate the **Element Size** section. From the **Predefined** list, choose **Finer**.

Size 2

1 Right-click **Size 1** and choose **Duplicate**.

2 In the **Settings** window for **Size**, locate the **Geometric Entity Selection** section.

3 Click  **Clear Selection**.

4 Click  **Paste Selection**.

5 In the **Paste Selection** dialog, type 17 in the **Selection** text field.

6 Click **OK**.



7 In the **Settings** window for **Size**, locate the **Element Size** section.

8 Click the **Custom** button.

9 Locate the **Element Size Parameters** section.

10 Select the **Maximum element size** checkbox. In the associated text field, type 0.00075.

Size 3

- 1 Right-click **Size 2** and choose **Duplicate**.
- 2 In the **Settings** window for **Size**, locate the **Geometric Entity Selection** section.
- 3 Click  **Clear Selection**.
- 4 Click  **Paste Selection**.
- 5 In the **Paste Selection** dialog, type 8 in the **Selection** text field.
- 6 Click **OK**.
- 7 In the **Settings** window for **Size**, locate the **Element Size Parameters** section.
- 8 In the **Maximum element size** text field, type 0.00125.

Boundary Layers 1

- 1 In the **Mesh** toolbar, click  **Boundary Layers**.
- 2 In the **Settings** window for **Boundary Layers**, locate the **Domain Selection** section.
- 3 From the **Geometric entity level** list, choose **Domain**.
- 4 Select Domain 19 only.

Boundary Layer Properties

- 1 In the **Model Builder** window, click **Boundary Layer Properties**.
- 2 In the **Settings** window for **Boundary Layer Properties**, locate the **Boundary Selection** section.
- 3 Click  **Paste Selection**.
- 4 In the **Paste Selection** dialog, type 163 164 in the **Selection** text field.
- 5 Click **OK**.

Boundary Layers 2

- 1 In the **Mesh** toolbar, click  **Boundary Layers**.
- 2 In the **Settings** window for **Boundary Layers**, locate the **Domain Selection** section.
- 3 From the **Geometric entity level** list, choose **Domain**.
- 4 Select Domain 18 only.

Boundary Layer Properties

- 1 In the **Model Builder** window, click **Boundary Layer Properties**.
- 2 In the **Settings** window for **Boundary Layer Properties**, locate the **Boundary Selection** section.
- 3 Click  **Paste Selection**.
- 4 In the **Paste Selection** dialog, type 161 162 in the **Selection** text field.



5 Click **OK**.

Next, add a Multibody Dynamics interface to the 3D component.



COMPONENT 2 (COMP2)

In the **Model Builder** window, click **Component 2 (comp2)**.



ADD PHYSICS

- 1 In the **Home** toolbar, click  **Add Physics** to open the **Add Physics** window.
- 2 Go to the **Add Physics** window.
- 3 In the tree, select **Structural Mechanics > Multibody Dynamics (mbd)**.
- 4 Click the **Add to Component 2** button in the window toolbar.
- 5 In the **Home** toolbar, click  **Add Physics** to close the **Add Physics** window.

MULTIBODY DYNAMICS (MBD)

- 1 Click the  **Click and Hide** button in the **Graphics** toolbar.
- 2 Select Domain 14 only.
- 3 Click the  **Click and Hide** button in the **Graphics** toolbar.
- 4 Select Domains 1–4, 6–15, 17, 18, 21, 23, 25, 27, and 29–36 only.

ADD MATERIAL

- 1 In the **Materials** toolbar, click  **Add Material** to open the **Add Material** window.
- 2 Go to the **Add Material** window.
- 3 In the tree, select **Built-in > Structural steel**.
- 4 Click the **Add to Component** button in the window toolbar.
- 5 In the tree, select **Built-in > Aluminum**.
- 6 Click the **Add to Component** button in the window toolbar.
- 7 In the **Materials** toolbar, click  **Add Material** to close the **Add Material** window.

MATERIALS



Aluminum (mat6)

- 1 In the **Settings** window for **Material**, locate the **Geometric Entity Selection** section.
- 2 Click  **Paste Selection**.
- 3 In the **Paste Selection** dialog, type 6 in the **Selection** text field.
- 4 Click **OK**.

MULTIBODY DYNAMICS (MBD)

Add **Rigid Material** nodes for modeling the rotor and stator. Also apply electromagnetic torque and forces on both parts.

Rigid Material: Rotor with Shaft

- 1 In the **Physics** toolbar, click  **Domains** and choose **Rigid Material**.
- 2 In the **Settings** window for **Rigid Material**, type Rigid Material: Rotor with Shaft in the **Label** text field.
- 3 Locate the **Domain Selection** section. Click  **Paste Selection**.
- 4 In the **Paste Selection** dialog, type 1-4, 6-12 in the **Selection** text field.
- 5 Click **OK**.

Applied Force 1

- 1 In the **Physics** toolbar, click  **Attributes** and choose **Applied Force**.
- 2 In the **Settings** window for **Applied Force**, locate the **Location** section.
- 3 From the list, choose **Centroid of selected entities**.

Location: Boundary 1

- 1 In the **Model Builder** window, expand the **Applied Force 1** node, then click **Location: Boundary 1**.
- 2 In the **Settings** window for **Location: Boundary**, locate the **Boundary Selection** section.
- 3 Click  **Paste Selection**.
- 4 In the **Paste Selection** dialog, type 45-53 in the **Selection** text field.
- 5 Click **OK**.

Applied Force 1

- 1 In the **Model Builder** window, click **Applied Force 1**.
- 2 In the **Settings** window for **Applied Force**, locate the **Applied Force** section.
- 3 Specify the \mathbf{F} vector as

0	x
comp1.rmm.Forcex_Rotor	y
comp1.rmm.Forcey_Rotor	z

Rigid Material: Rotor with Shaft

In the **Model Builder** window, click **Rigid Material: Rotor with Shaft**.

Applied Moment I

- 1 In the **Physics** toolbar, click  **Attributes** and choose **Applied Moment**.
- 2 In the **Settings** window for **Applied Moment**, locate the **Applied Moment** section.
- 3 Specify the **M** vector as

comp1.rmm.Tax_Rotor	x
0	y
0	z

Rigid Material: Stator

- 1 In the **Physics** toolbar, click  **Domains** and choose **Rigid Material**.
- 2 In the **Settings** window for **Rigid Material**, type Rigid Material: Stator in the **Label** text field.
- 3 Locate the **Domain Selection** section. Click  **Paste Selection**.
- 4 In the **Paste Selection** dialog, type 15, 17-18, 21, 23, 25, 27 in the **Selection** text field.
- 5 Click **OK**.

Applied Force I

- 1 In the **Physics** toolbar, click  **Attributes** and choose **Applied Force**.
- 2 In the **Settings** window for **Applied Force**, locate the **Applied Force** section.
- 3 Specify the **F** vector as

0	x
comp1.rmm.Forcex_Stator	y
comp1.rmm.Forcey_Stator	z

Rigid Material: Stator

In the **Model Builder** window, click **Rigid Material: Stator**.

Applied Moment I



- 1 In the **Physics** toolbar, click  **Attributes** and choose **Applied Moment**.
- 2 In the **Settings** window for **Applied Moment**, locate the **Applied Moment** section.
- 3 Specify the **M** vector as

comp1.rmm.Tax_Stator	x
----------------------	---



0	y
0	z

Next is to define the rotor-housing and housing-foundation connections using elastic **Hinge Joints** and **Fixed Joints** respectively.

Attachment: Bearing 1

- 1 In the **Physics** toolbar, click  **Boundaries** and choose **Attachment**.
- 2 In the **Settings** window for **Attachment**, type Attachment: Bearing 1 in the **Label** text field.
- 3 Locate the **Boundary Selection** section. Click  **Paste Selection**.
- 4 In the **Paste Selection** dialog, type 183-184, 186-187 in the **Selection** text field.
- 5 Click **OK**.

Attachment: Bearing 2

- 1 In the **Physics** toolbar, click  **Boundaries** and choose **Attachment**.
- 2 In the **Settings** window for **Attachment**, type Attachment: Bearing 2 in the **Label** text field.
- 3 Locate the **Boundary Selection** section. Click  **Paste Selection**.
- 4 In the **Paste Selection** dialog, type 498-501 in the **Selection** text field.
- 5 Click **OK**.

Hinge Joint: Bearing 1

- 1 In the **Physics** toolbar, click  **Global** and choose **Hinge Joint**.
- 2 In the **Settings** window for **Hinge Joint**, type Hinge Joint: Bearing 1 in the **Label** text field.
- 3 Locate the **Attachment Selection** section. From the **Source** list, choose **Attachment: Bearing 1**.
- 4 From the **Destination** list, choose **Rigid Material: Rotor with Shaft**.
- 5 Locate the **Joint Elasticity** section. From the list, choose **Elastic joint**.

Joint Elasticity 1

- 1 In the **Model Builder** window, expand the **Hinge Joint: Bearing 1** node, then click **Joint Elasticity 1**.
- 2 In the **Settings** window for **Joint Elasticity**, locate the **Spring** section.
- 3 In the k_u text field, type kb.
- 4 In the k_θ text field, type kbr.



Hinge Joint: Bearing 2

- 1 In the **Model Builder** window, right-click **Hinge Joint: Bearing 1** and choose **Duplicate**.
- 2 In the **Settings** window for **Hinge Joint**, type Hinge Joint: Bearing 2 in the **Label** text field.
- 3 Locate the **Attachment Selection** section. From the **Source** list, choose **Attachment: Bearing 2**.



Attachment: Foundation 1

- 1 In the **Model Builder** window, expand the **Hinge Joint: Bearing 2** node.
- 2 Right-click **Multibody Dynamics (mbd)** and choose **Attachment**.
- 3 In the **Settings** window for **Attachment**, type Attachment: Foundation 1 in the **Label** text field.
- 4 Locate the **Boundary Selection** section. Click  **Paste Selection**.
- 5 In the **Paste Selection** dialog, type 390-391 in the **Selection** text field.
- 6 Click **OK**.

Attachment: Foundation 2



- 1 Right-click **Attachment: Foundation 1** and choose **Duplicate**.
- 2 In the **Settings** window for **Attachment**, type Attachment: Foundation 2 in the **Label** text field.
- 3 Locate the **Boundary Selection** section. Click  **Clear Selection**.
- 4 Click  **Paste Selection**.
- 5 In the **Paste Selection** dialog, type 470-471 in the **Selection** text field.
- 6 Click **OK**.

Attachment: Foundation 3

- 1 Right-click **Attachment: Foundation 2** and choose **Duplicate**.
- 2 In the **Settings** window for **Attachment**, type Attachment: Foundation 3 in the **Label** text field.
- 3 Locate the **Boundary Selection** section. Click  **Clear Selection**.
- 4 Click  **Paste Selection**.
- 5 In the **Paste Selection** dialog, type 472-473 in the **Selection** text field.
- 6 Click **OK**.

Attachment: Foundation 4

- 1 Right-click **Attachment: Foundation 3** and choose **Duplicate**.

- 2 In the **Settings** window for **Attachment**, type Attachment: Foundation 4 in the **Label** text field.
- 3 Locate the **Boundary Selection** section. Click  **Clear Selection**.
- 4 Click  **Paste Selection**.
- 5 In the **Paste Selection** dialog, type 392-393 in the **Selection** text field.
- 6 Click **OK**.

Fixed Joint: Foundation 1

- 1 In the **Physics** toolbar, click  **Global** and choose **Fixed Joint**.
- 2 In the **Settings** window for **Fixed Joint**, type Fixed Joint: Foundation 1 in the **Label** text field.
- 3 Locate the **Attachment Selection** section. From the **Source** list, choose **Fixed**.
- 4 From the **Destination** list, choose **Attachment: Foundation 1**.
- 5 Locate the **Joint Elasticity** section. From the list, choose **Elastic joint**.

Joint Elasticity 1

- 1 In the **Model Builder** window, expand the **Fixed Joint: Foundation 1** node, then click **Joint Elasticity 1**.
- 2 In the **Settings** window for **Joint Elasticity**, locate the **Spring** section.
- 3 In the k_u text field, type kf.
- 4 In the k_θ text field, type kfr.

Fixed Joint: Foundation 2

- 1 In the **Model Builder** window, right-click **Fixed Joint: Foundation 1** and choose **Duplicate**.
- 2 In the **Settings** window for **Fixed Joint**, type Fixed Joint: Foundation 2 in the **Label** text field.
- 3 Locate the **Attachment Selection** section. From the **Destination** list, choose **Attachment: Foundation 2**.

Fixed Joint: Foundation 3

- 1 Right-click **Fixed Joint: Foundation 2** and choose **Duplicate**.
- 2 In the **Settings** window for **Fixed Joint**, type Fixed Joint: Foundation 3 in the **Label** text field.
- 3 Locate the **Attachment Selection** section. From the **Destination** list, choose **Attachment: Foundation 3**.

Fixed Joint: Foundation 4

- 1 Right-click **Fixed Joint: Foundation 3** and choose **Duplicate**.
- 2 In the **Settings** window for **Fixed Joint**, type **Fixed Joint: Foundation 4** in the **Label** text field.
- 3 Locate the **Attachment Selection** section. From the **Destination** list, choose **Attachment: Foundation 4**.

COMPONENT 1 (COMP1)

In the **Model Builder** window, click **Component 1 (comp1)**.

Rotating Domain 1

- 1 In the **Physics** toolbar, click  **Moving Mesh** and choose **Rotating Domain**.
- 2 Select Domains 17–20 only.
- 3 In the **Settings** window for **Rotating Domain**, locate the **Rotation** section.
- 4 In the α text field, type `comp2.mbd.hgj1.th`.
- 5 Locate the **Axis** section. Specify the \mathbf{r}_{ax} vector as

0	X
dy	Y

MESH 2

- 1 In the **Model Builder** window, under **Component 2 (comp2)** click **Mesh 2**.
- 2 In the **Settings** window for **Mesh**, locate the **Physics-Controlled Mesh** section.
- 3 In the table, clear the **Use** checkbox for **Geometric Analysis, Detail Size**.
- 4 Click  **Build All**.

STUDY 1

Step 1: Time Dependent

- 1 In the **Settings** window for **Time Dependent**, locate the **Study Settings** section.
- 2 In the **Output times** text field, type range (0,0.001,0.7).
- 3 From the **Tolerance** list, choose **User controlled**.
- 4 In the **Relative tolerance** text field, type 0.001.

Solution 1 (sol1)

- 1 In the **Study** toolbar, click  **Show Default Solver**.

- 2 In the **Model Builder** window, expand the **Solution I (sol1)** node, then click **Time-Dependent Solver I**.
- 3 In the **Settings** window for **Time-Dependent Solver**, click to expand the **Time Stepping** section.
- 4 From the **Steps taken by solver** list, choose **Intermediate**.
- 5 From the **Maximum step constraint** list, choose **Constant**.
- 6 In the **Maximum step** text field, type 0.0002.
- 7 From the **Maximum BDF order** list, choose **2**.
- 8 In the **Model Builder** window, expand the **Study I > Solver Configurations > Solution I (sol1) > Time-Dependent Solver I** node.
- 9 In the **Model Builder** window, expand the **Study I > Solver Configurations > Solution I (sol1) > Time-Dependent Solver I** node, then click **Direct**.
- 10 In the **Settings** window for **Direct**, locate the **General** section.
- 11 From the **Solver** list, choose **PARDISO**.
- 12 In the **Model Builder** window, expand the **Study I > Solver Configurations > Solution I (sol1) > Time-Dependent Solver I > Segregated I** node, then click **Multibody Dynamics**.
- 13 In the **Settings** window for **Segregated Step**, click to expand the **Method and Termination** section.
- 14 From the **Jacobian update** list, choose **Once per time step**.
- 15 From the **Termination technique** list, choose **Tolerance**.
- 16 In the **Tolerance factor** text field, type 1.
- 17 In the **Model Builder** window, click **Study I**.
- 18 In the **Settings** window for **Study**, locate the **Study Settings** section.
- 19 Clear the **Generate default plots** checkbox.
- 20 In the **Study** toolbar, click  **Compute**.

RESULTS

Follow the instructions below to plot the magnetic flux density, electromagnetic torque, and the angular speed of the rotor as shown in [Figure 3](#), [Figure 5](#) and [Figure 6](#) respectively.

Magnetic Flux Density Norm

- 1 In the **Results** toolbar, click  **2D Plot Group**.

- 2 In the **Settings** window for **2D Plot Group**, type **Magnetic Flux Density Norm** in the **Label** text field.
- 3 Locate the **Plot Settings** section. From the **Frame** list, choose **Spatial (x, y, z)**.

Surface 1

Right-click **Magnetic Flux Density Norm** and choose **Surface**.

Arrow Surface 1

- 1 In the **Model Builder** window, right-click **Magnetic Flux Density Norm** and choose **Arrow Surface**.
- 2 In the **Settings** window for **Arrow Surface**, locate the **Arrow Positioning** section.
- 3 Find the **x grid points** subsection. In the **Points** text field, type 50.
- 4 Find the **y grid points** subsection. In the **Points** text field, type 50.
- 5 Locate the **Coloring and Style** section.
- 6 Select the **Scale factor** checkbox. In the associated text field, type 0.055.

Study 1/Solution 1 (1) (sol1)

In the **Model Builder** window, expand the **Results > Datasets** node, then click **Study 1/Solution 1 (1) (sol1)**.

Selection

- 1 Right-click **Study 1/Solution 1 (1) (sol1)** and choose **Selection**.
- 2 In the **Settings** window for **Selection**, locate the **Geometric Entity Selection** section.
- 3 From the **Geometric entity level** list, choose **Domain**.
- 4 Click  **Paste Selection**.
- 5 In the **Paste Selection** dialog, type 4-20 in the **Selection** text field.
- 6 Click **OK**.

Study 1/Solution 1 (3) (sol1)

In the **Model Builder** window, under **Results > Datasets** right-click **Study 1/Solution 1 (2) (sol1)** and choose **Duplicate**.

Selection

- 1 In the **Model Builder** window, right-click **Study 1/Solution 1 (3) (sol1)** and choose **Selection**.
- 2 In the **Settings** window for **Selection**, locate the **Geometric Entity Selection** section.
- 3 From the **Geometric entity level** list, choose **Domain**.
- 4 Click  **Paste Selection**.

5 In the **Paste Selection** dialog, type 13, 29-36 in the **Selection** text field.

6 Click **OK**.

Study 1/Solution 1 (4) (sol1)

In the **Model Builder** window, under **Results** > **Datasets** right-click **Study 1/Solution 1 (3) (sol1)** and choose **Duplicate**.

Selection

1 In the **Model Builder** window, expand the **Study 1/Solution 1 (4) (sol1)** node, then click **Selection**.

2 In the **Settings** window for **Selection**, locate the **Geometric Entity Selection** section.

3 Click  **Clear Selection**.

4 Click  **Paste Selection**.

5 In the **Paste Selection** dialog, type 1-4, 6-12, 17, 21, 25, 27 in the **Selection** text field.

6 Click **OK**.

Magnetic Flux Density Norm

1 In the **Model Builder** window, under **Results** click **Magnetic Flux Density Norm**.

2 In the **Magnetic Flux Density Norm** toolbar, click  **Plot**.

3 Click the  **Zoom Extents** button in the **Graphics** toolbar.

Electromagnetic Torque (Rotor)

1 In the **Results** toolbar, click  **ID Plot Group**.

2 In the **Settings** window for **ID Plot Group**, type Electromagnetic Torque (Rotor) in the **Label** text field.

3 Click to expand the **Title** section. From the **Title type** list, choose **Manual**.

4 In the **Title** text area, type Electromagnetic Torque (Rotor).

Global 1

1 Right-click **Electromagnetic Torque (Rotor)** and choose **Global**.



2 In the **Settings** window for **Global**, locate the **y-Axis Data** section.

3 In the table, enter the following settings:

Expression	Unit	Description
comp1.rmm.Tax_Rotor	N*m	Torque, z-component

4 Click to expand the **Coloring and Style** section. From the **Width** list, choose **2**.

Electromagnetic Torque (Rotor)

- 1 In the **Model Builder** window, click **Electromagnetic Torque (Rotor)**.
- 2 In the **Settings** window for **ID Plot Group**, locate the **Legend** section.
- 3 Clear the **Show legends** checkbox.
- 4 In the **Electromagnetic Torque (Rotor)** toolbar, click  **Plot**.
- 5 Click the  **Zoom Extents** button in the **Graphics** toolbar.



Rotor Speed

- 1 Right-click **Electromagnetic Torque (Rotor)** and choose **Duplicate**.
- 2 In the **Settings** window for **ID Plot Group**, type Rotor Speed in the **Label** text field.
- 3 Locate the **Title** section. In the **Title** text area, type Rotor Speed.

Global 1

- 1 In the **Model Builder** window, expand the **Rotor Speed** node, then click **Global 1**.
- 2 In the **Settings** window for **Global**, locate the **y-Axis Data** section.
- 3 In the table, enter the following settings:

Expression	Unit	Description
comp2.mbd.hgj1.Tht	rad/s	Relative angular velocity

- 4 In the **Rotor Speed** toolbar, click  **Plot**.
- 5 Click the  **Zoom Extents** button in the **Graphics** toolbar.

Follow the instructions below to plot the electromagnetic forces as a function of time and its frequency spectrum as shown in [Figure 7](#) and [Figure 8](#) respectively.

Electromagnetic Forces (Rotor)

- 1 In the **Model Builder** window, right-click **Rotor Speed** and choose **Duplicate**.
- 2 In the **Settings** window for **ID Plot Group**, type Electromagnetic Forces (Rotor) in the **Label** text field.
- 3 Locate the **Title** section. In the **Title** text area, type Electromagnetic Forces (Rotor).



Global 1

- 1 In the **Model Builder** window, expand the **Electromagnetic Forces (Rotor)** node, then click **Global 1**.
- 2 In the **Settings** window for **Global**, locate the **y-Axis Data** section.

3 In the table, enter the following settings:

Expression	Unit	Description
rmm.Forcex_Rotor	N	Electromagnetic force, x-component
rmm.Forcey_Rotor	N	Electromagnetic force, y-component



Electromagnetic Forces (Rotor)

- 1 In the **Model Builder** window, click **Electromagnetic Forces (Rotor)**.
- 2 In the **Settings** window for **ID Plot Group**, locate the **Legend** section.
- 3 Select the **Show legends** checkbox.
- 4 From the **Position** list, choose **Lower left**.
- 5 Locate the **Plot Settings** section.
- 6 Select the **y-axis label** checkbox. In the associated text field, type Force (N).
- 7 In the **Electromagnetic Forces (Rotor)** toolbar, click  **Plot**.
- 8 Click the  **Zoom Extents** button in the **Graphics** toolbar.

Electromagnetic Forces (Rotor): Frequency

- 1 Right-click **Electromagnetic Forces (Rotor)** and choose **Duplicate**.
- 2 In the **Settings** window for **ID Plot Group**, type Electromagnetic Forces (Rotor): Frequency in the **Label** text field.
- 3 Locate the **Plot Settings** section. Clear the **y-axis label** checkbox.
- 4 Locate the **Legend** section. From the **Position** list, choose **Upper right**.

Global I

- 1 In the **Model Builder** window, expand the **Electromagnetic Forces (Rotor): Frequency** node, then click **Global I**.
- 2 In the **Settings** window for **Global**, locate the **x-Axis Data** section.
- 3 From the **Parameter** list, choose **Discrete Fourier transform**.
- 4 From the **Show** list, choose **Frequency spectrum**.
- 5 Select the **Frequency range** checkbox.
- 6 In the **Maximum** text field, type 300.
- 7 In the **Electromagnetic Forces (Rotor): Frequency** toolbar, click  **Plot**.
- 8 Click the  **Zoom Extents** button in the **Graphics** toolbar.

Follow the instructions below to plot the bearing and foundation forces as shown in [Figure 9](#), [Figure 10](#), [Figure 11](#) and [Figure 12](#) respectively.

Forces (Bearing-1)

- 1 In the **Model Builder** window, right-click **Electromagnetic Forces (Rotor)** and choose **Duplicate**.
- 2 In the **Settings** window for **ID Plot Group**, type Forces (Bearing-1) in the **Label** text field.
- 3 Locate the **Title** section. In the **Title** text area, type Forces (Bearing-1).

Global 1



- 1 In the **Model Builder** window, expand the **Forces (Bearing-1)** node, then click **Global 1**.
- 2 In the **Settings** window for **Global**, locate the **y-Axis Data** section.
- 3 In the table, enter the following settings:

Expression	Unit	Description
comp2.mbd.hgj1.Fx	N	Joint force, x-component
comp2.mbd.hgj1.Fy	N	Joint force, y-component
comp2.mbd.hgj1.Fz	N	Joint force, z-component

- 4 Click to expand the **Legends** section. From the **Legends** list, choose **Manual**.
- 5 In the table, enter the following settings:

Legends
x-component
y-component
z-component

Forces (Bearing-1)

- 1 In the **Model Builder** window, click **Forces (Bearing-1)**.
- 2 In the **Settings** window for **ID Plot Group**, locate the **Legend** section.
- 3 From the **Position** list, choose **Upper left**.
- 4 In the **Forces (Bearing-1)** toolbar, click  **Plot**.
- 5 Click the  **Zoom Extents** button in the **Graphics** toolbar.



Forces (Bearing-2)

- 1 Right-click **Forces (Bearing-1)** and choose **Duplicate**.
- 2 In the **Settings** window for **ID Plot Group**, type Forces (Bearing-2) in the **Label** text field.
- 3 Locate the **Title** section. In the **Title** text area, type Forces (Bearing-2).

Global 1

- 1 In the **Model Builder** window, expand the **Forces (Bearing-2)** node, then click **Global 1**.
- 2 In the **Settings** window for **Global**, locate the **y-Axis Data** section.
- 3 In the table, enter the following settings:

Expression	Unit	Description
comp2.mbd.hgj2.Fx	N	Joint force, x-component
comp2.mbd.hgj2.Fy	N	Joint force, y-component
comp2.mbd.hgj2.Fz	N	Joint force, z-component

- 4 In the **Forces (Bearing-2)** toolbar, click  **Plot**.
- 5 Click the  **Zoom Extents** button in the **Graphics** toolbar.



Forces (Foundation-1)

- 1 In the **Model Builder** window, right-click **Forces (Bearing-2)** and choose **Duplicate**.
- 2 In the **Settings** window for **ID Plot Group**, type Forces (Foundation-1) in the **Label** text field.
- 3 Locate the **Title** section. In the **Title** text area, type Forces (Foundation-1).

Global 1

- 1 In the **Model Builder** window, expand the **Forces (Foundation-1)** node, then click **Global 1**.
- 2 In the **Settings** window for **Global**, locate the **y-Axis Data** section.
- 3 In the table, enter the following settings:

Expression	Unit	Description
comp2.mbd.fxj1.Fx	N	Joint force, x-component
comp2.mbd.fxj1.Fy	N	Joint force, y-component
comp2.mbd.fxj1.Fz	N	Joint force, z-component

- 4 In the **Forces (Foundation-1)** toolbar, click  **Plot**.
- 5 Click the  **Zoom Extents** button in the **Graphics** toolbar.



Forces (Foundation-1): Frequency

- 1 In the **Model Builder** window, right-click **Forces (Foundation-1)** and choose **Duplicate**.
- 2 In the **Settings** window for **ID Plot Group**, type Forces (Foundation-1): Frequency in the **Label** text field.

Global 1

- 1 In the **Model Builder** window, expand the **Forces (Foundation-1) 1** node, then click **Results > Forces (Foundation-1): Frequency > Global 1**.
- 2 In the **Settings** window for **Global**, locate the **x-Axis Data** section.
- 3 From the **Parameter** list, choose **Discrete Fourier transform**.
- 4 From the **Show** list, choose **Frequency spectrum**.
- 5 Select the **Frequency range** checkbox.
- 6 In the **Maximum** text field, type 300.

Forces (Foundation-1): Frequency

- 1 In the **Model Builder** window, click **Forces (Foundation-1): Frequency**.
- 2 In the **Settings** window for **ID Plot Group**, locate the **Legend** section.
- 3 From the **Position** list, choose **Upper right**.
- 4 Locate the **Plot Settings** section. Clear the **y-axis label** checkbox.
- 5 In the **Forces (Foundation-1): Frequency** toolbar, click  **Plot**.
- 6 Click the  **Zoom Extents** button in the **Graphics** toolbar.

Follow the instructions below to plot the orbital motion of the rotor as shown in [Figure 13](#).

Rotor Orbits

- 1 In the **Results** toolbar, click  **ID Plot Group**.
- 2 In the **Settings** window for **ID Plot Group**, type Rotor Orbits in the **Label** text field.
- 3 Locate the **Title** section. From the **Title type** list, choose **Manual**.
- 4 In the **Title** text area, type Rotor Orbits.
- 5 Locate the **Data** section. From the **Dataset** list, choose **Study 1/Solution 1 (2) (sol1)**.

Global 1

- 1 Right-click **Rotor Orbits** and choose **Global**.
- 2 In the **Settings** window for **Global**, locate the **y-Axis Data** section.
- 3 In the table, enter the following settings:

Expression	Unit	Description
mbd.hgj1.u2	mm	Displacement (y direction)

- 4 Locate the **x-Axis Data** section. From the **Parameter** list, choose **Expression**.
- 5 In the **Expression** text field, type mbd.hgj1.u3.

- 6 From the **Unit** list, choose **mm**.
- 7 Select the **Description** checkbox. In the associated text field, type Displacement (z direction).

Color Expression 1

- 1 Right-click **Global 1** and choose **Color Expression**.
- 2 In the **Settings** window for **Color Expression**, locate the **Expression** section.
- 3 In the **Expression** text field, type t.

Global 2

- 1 In the **Model Builder** window, under **Results > Rotor Orbits** right-click **Global 1** and choose **Duplicate**.
- 2 In the **Settings** window for **Global**, locate the **y-Axis Data** section.
- 3 In the table, enter the following settings:

Expression	Unit	Description
mbd.hgj2.u2	mm	Displacement (y direction)

- 4 Locate the **x-Axis Data** section. In the **Expression** text field, type mbd.hgj2.u3.

Annotation 1



- 1 In the **Model Builder** window, right-click **Rotor Orbits** and choose **Annotation**.
- 2 In the **Settings** window for **Annotation**, locate the **Annotation** section.
- 3 In the **Text** text field, type Bearing 1.
- 4 Locate the **Position** section. In the **X** text field, type 1e-3.
- 5 In the **Y** text field, type -1e-3.
- 6 Locate the **Coloring and Style** section. Clear the **Show point** checkbox.

Annotation 2

- 1 Right-click **Annotation 1** and choose **Duplicate**.
- 2 In the **Settings** window for **Annotation**, locate the **Annotation** section.
- 3 In the **Text** text field, type Bearing 2.
- 4 Locate the **Position** section. In the **X** text field, type -3e-3.
- 5 In the **Y** text field, type 1.5e-3.

Rotor Orbits

- 1 In the **Model Builder** window, click **Rotor Orbits**.
- 2 In the **Settings** window for **ID Plot Group**, locate the **Legend** section.

- 3 Clear the **Show legends** checkbox.
- 4 Locate the **Axis** section. Select the **Preserve aspect ratio** checkbox.
- 5 In the **Rotor Orbits** toolbar, click  **Plot**.
- 6 Click the  **Zoom Extents** button in the **Graphics** toolbar.



Housing Stress

- 1 In the **Results** toolbar, click  **3D Plot Group**.
- 2 In the **Settings** window for **3D Plot Group**, locate the **Data** section.
- 3 From the **Dataset** list, choose **Study 1/Solution 1 (3) (sol1)**.
- 4 In the **Label** text field, type Housing Stress.

Surface 1

- 1 Right-click **Housing Stress** and choose **Surface**.
- 2 In the **Settings** window for **Surface**, locate the **Expression** section.
- 3 In the **Expression** text field, type `mbd.mises`.
- 4 Click to expand the **Range** section. Select the **Manual color range** checkbox.
- 5 In the **Maximum** text field, type `5e4`.
- 6 Locate the **Coloring and Style** section. From the **Color table** list, choose **TrafficLight**.

Deformation 1

- 1 Right-click **Surface 1** and choose **Deformation**.
- 2 In the **Settings** window for **Deformation**, locate the **Scale** section.
- 3 Select the **Scale factor** checkbox. In the associated text field, type `2000`.
- 4 In the **Housing Stress** toolbar, click  **Plot**.
- 5 Click the  **Zoom Extents** button in the **Graphics** toolbar.

Housing Stress (with Rotor)

- 1 In the **Model Builder** window, right-click **Housing Stress** and choose **Duplicate**.
- 2 In the **Settings** window for **3D Plot Group**, type Housing Stress (with Rotor) in the **Label** text field.
- 3 Locate the **Data** section. From the **Dataset** list, choose **Study 1/Solution 1 (2) (sol1)**.
- 4 Locate the **Plot Settings** section. From the **Frame** list, choose **Spatial (x, y, z)**.

Surface 1

- 1 In the **Model Builder** window, expand the **Housing Stress (with Rotor)** node, then click **Surface 1**.

- 2 In the **Settings** window for **Surface**, locate the **Data** section.
- 3 From the **Dataset** list, choose **Study 1/Solution 1 (3) (sol1)**.
- 4 From the **Solution parameters** list, choose **From parent**.

Deformation 1

- 1 In the **Model Builder** window, expand the **Surface 1** node, then click **Deformation 1**.
- 2 In the **Settings** window for **Deformation**, locate the **Scale** section.
- 3 In the **Scale factor** text field, type 1.

Contour 1

- 1 In the **Model Builder** window, right-click **Housing Stress (with Rotor)** and choose **Contour**.
- 2 In the **Settings** window for **Contour**, locate the **Data** section.
- 3 From the **Dataset** list, choose **Study 1/Solution 1 (3) (sol1)**.
- 4 From the **Solution parameters** list, choose **From parent**.
- 5 Locate the **Expression** section. In the **Expression** text field, type `mbd.mises`.
- 6 Locate the **Levels** section. In the **Total levels** text field, type 10.
- 7 Locate the **Coloring and Style** section. From the **Coloring** list, choose **Uniform**.
- 8 From the **Color** list, choose **Black**.
- 9 Click to expand the **Title** section. From the **Title type** list, choose **None**.
- 10 Locate the **Coloring and Style** section. Clear the **Color legend** checkbox.

Deformation 1

- 1 Right-click **Contour 1** and choose **Deformation**.
- 2 In the **Settings** window for **Deformation**, locate the **Scale** section.
- 3 Select the **Scale factor** checkbox. In the associated text field, type 1.

Surface 2



- 1 In the **Model Builder** window, right-click **Housing Stress (with Rotor)** and choose **Surface**.
- 2 In the **Settings** window for **Surface**, locate the **Data** section.
- 3 From the **Dataset** list, choose **Study 1/Solution 1 (4) (sol1)**.
- 4 From the **Solution parameters** list, choose **From parent**.
- 5 Locate the **Expression** section. In the **Expression** text field, type `mbd.vel`.
- 6 Locate the **Coloring and Style** section. From the **Color table** list, choose **AuroraBorealis**.

Deformation 1

- 1 Right-click **Surface 2** and choose **Deformation**.

- 2 In the **Settings** window for **Deformation**, locate the **Scale** section.
- 3 Select the **Scale factor** checkbox. In the associated text field, type 1.

Housing Stress (with Rotor)

- 1 In the **Model Builder** window, under **Results** click **Housing Stress (with Rotor)**.
- 2 In the **Settings** window for **3D Plot Group**, locate the **Color Legend** section.
- 3 From the **Position** list, choose **Right double**.
- 4 In the **Housing Stress (with Rotor)** toolbar, click  **Plot**.
- 5 Click the  **Zoom Extents** button in the **Graphics** toolbar.

Create animations to visualize the variation of magnetic flux density and stress distribution in different parts of the motor over time.

Animation 1

- 1 In the **Results** toolbar, click  **Animation** and choose **Player**.
- 2 In the **Settings** window for **Animation**, locate the **Frames** section.
- 3 In the **Number of frames** text field, type 50.

Animation 2

- 1 Right-click **Animation 1** and choose **Duplicate**.
- 2 In the **Settings** window for **Animation**, locate the **Scene** section.
- 3 From the **Subject** list, choose **Housing Stress**.
- 4 Locate the **Animation Editing** section. From the **Time selection** list, choose **Interpolated**.
- 5 In the **Times (s)** text field, type range (0,0.01,0.7).
- 6 Locate the **Frames** section. In the **Number of frames** text field, type 70.

Animation 3

- 1 Right-click **Animation 2** and choose **Duplicate**.
- 2 In the **Settings** window for **Animation**, locate the **Scene** section.
- 3 From the **Subject** list, choose **Housing Stress (with Rotor)**.