



Model created in COMSOL Multiphysics 6.4

Helicopter Swashplate Mechanism

Introduction

A swashplate is a device that translates the input of an helicopter flight control into the motion of rotor blades. As the rotor blades are spinning, the swashplate is used to transmit the pilot's commands from the nonrotating fuselage to the rotating rotor hub and blades.

This model is built using the Multibody Dynamics interface in COMSOL Multiphysics. Transient and eigenfrequency analyses of the swashplate mechanism are performed in the model. Two different cases are considered for the transient analysis. In the first case, all parts of the mechanism are assumed rigid, whereas in the second case the rotor blades are made flexible while keeping the rest of the components rigid. The deformation in the rotor blades is the difference of rigid body motion obtained in the first case and the motion obtained in the second case. The latter includes both the rigid body motion and deformation.

Model Definition

The model geometry is shown in [Figure 1](#). This section describes the components in the swashplate mechanism and the connections between them via different types of joints.

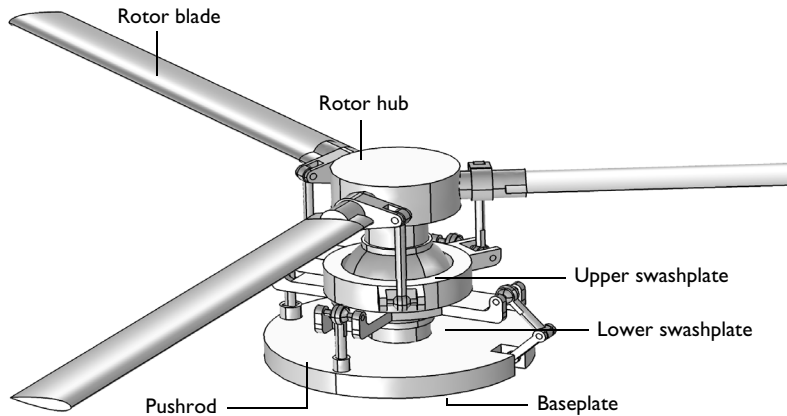

Figure 1: Geometry of the helicopter swashplate mechanism.

A list of all the components together with their state of motion is given below.

- Baseplate (stationary)
- Pushrod (3 in number, stationary)
- Baseplate-Swashplate Link (2 in number, stationary)

- Lower Swashplate (stationary)
- Upper Swashplate (rotating)
- Rotor Hub (rotating)
- Sphere (rotating)
- Rotor Blade (3 in number, rotating)
- Swashplate-Blade Link (3 in number, rotating)

The baseplate is mounted on the fuselage and is connected to the lower swashplate using pushrods and links. Reduced slot, hinge and prismatic joints are used at the baseplate end of the pushrods and links. Ball joints are used at the swashplate end of the pushrods and links.

The lower swashplate is also connected to the upper swashplate through a planar joint and to the sphere through a ball joint. The sphere is connected to the rotor hub through a cylindrical joint.

The upper swashplate is connected to the rotor blades using links. Ball joints are used at the swashplate end of the links, whereas hinge joints are used at the blade end of the links. The rotor blades are connected to the rotor hub with hinge joints.

The cross-section of the rotor blades is modeled using a symmetric airfoil shape, shown in [Figure 2](#).

MATERIAL

Structural steel is used as a material for all the components of the helicopter swashplate mechanism.

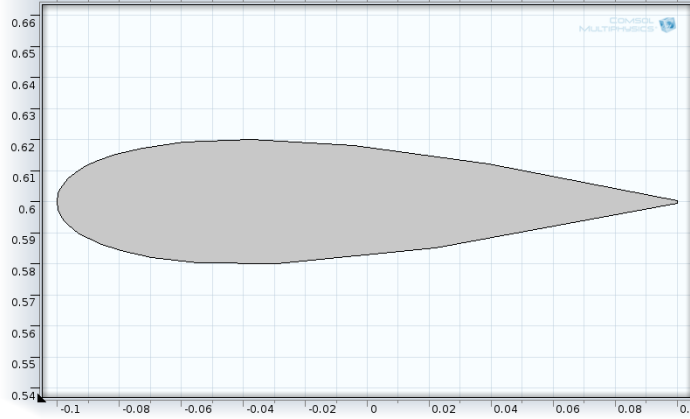

Figure 2: Cross-section of the rotor blades (symmetric airfoil shape).

LIFT FORCE ON THE ROTOR BLADES

The helicopter is moving forward with a velocity of 100 km/h. The helicopter rotor and the other rotating parts are initialized to rotate at 300 RPM.

The lift force acts on the rotor blades due to the unsymmetrical pressure distribution in the airflow over the blades. This is modeled as the following distributed boundary load on the bottom surfaces of the rotor blades:

$$F_l = 0,5\rho_a U_r^2 C_l \text{sgn}(U_r) \quad C_l = 4\alpha$$

$$U_r = \omega d - v_f \frac{y}{d} \quad d = \sqrt{x^2 + y^2}$$

where the parameters read:

- ρ_a — density of air (1 kg/m³)
- C_l — lift coefficient
- U_r — relative velocity at a point over the rotor blades
- α — angle of attack of rotor blades
- ω — angular velocity of rotor blades
- v_f — forward speed of helicopter
- d — distance of a point over the rotor blades from the center of rotation
- x, y — spatial coordinates of a point over the rotor blades

INITIAL AND BOUNDARY CONDITIONS

The rotor blades, along with all rotating components, are given an initial rotational velocity of 300 RPM. This is needed to avoid the transient effects in the solution.

The baseplate is fixed. The rotor's hub is prescribed to rotate at 300 RPM. The pushrods are prescribed to move upward with a constant velocity of 0.5 m/s for some time lapse. This is needed to push the swashplate assembly upward and provide the angle of attack to all the rotor blades. The motion of the second pushrod is prescribed for comparatively longer time. This is needed to tilt the swashplate assembly, which in turn changes the angle of attack of rotor blades.

MESH

The mesh in all parts of the helicopter swashplate mechanism is shown in [Figure 3](#). In this model, only the blades are modeled as flexible elements. Hence, a coarse mesh is used in all the other components.

A swept mesh is used to reduce the number of elements in the blades and yet to model the deformation of the blades accurately.

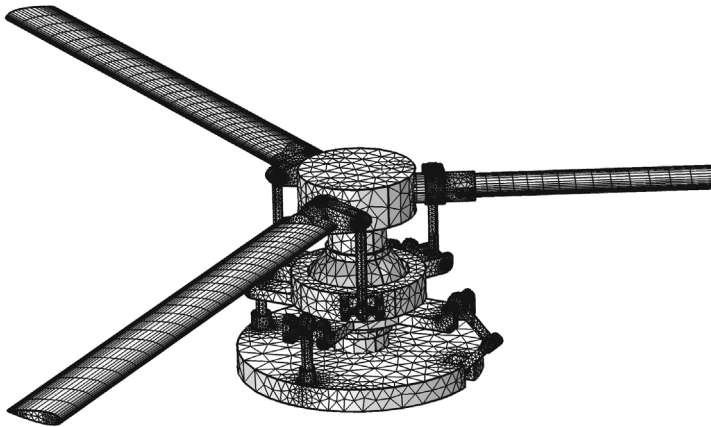

Figure 3: Mesh in the helicopter swashplate mechanism.

ANALYSES PERFORMED

The following three types of analyses are performed in this model:

- Transient analysis with rigid blades

- Transient analysis with flexible blades
- Eigenfrequency analysis with flexible blades

In case of eigenfrequency analysis, both the baseplate and rotor hub are fixed. The pushrods are free to move relative to the baseplate.

The second study also computes the displacement of the tip of one of the rotor blade which is pitching about its own axle as well as rotate about the rotor axis.

Results and Discussion

The configuration of the swashplate mechanism at $t = 0.3$ sec is shown in [Figure 4](#). The tilt of the swashplate assembly can be seen. The velocity of the components is shown with the help of an arrow plot.

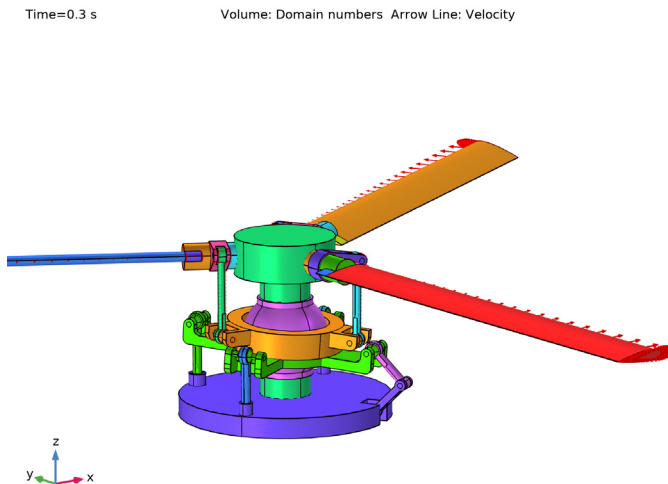

Figure 4: Configuration of the swashplate mechanism at a particular instant.

[Figure 5](#) shows the variation in the angle of attack of each rotor blade due to the tilt of the swashplate assembly with respect to the angular rotation.

Initially, all three pushrods move upward with the same velocity, which forces the swashplate to move upward. The upward motion then increases the angle of attack for all the blades. However, after a certain time, only one of the pushrods continues to move upward, which causes the tilt of the swashplate. This tilt provides a continuous change in the angle of attack with respect to the rotation of the rotor.

The angle of attack of each blade changes from 2° to 17° .

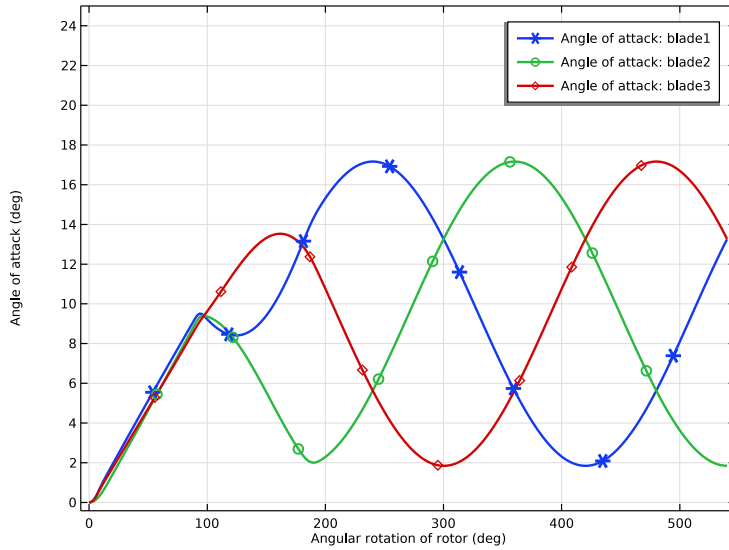

Figure 5: Variation of the angle of attack of each rotor blade (rigid case).

Figure 6 shows the total lift force applied on each blade and its variation with respect to the rotation. The total lift on the first blade is computed for the following two cases. First, when the swashplate is tilted, and hence the blades change their angle of attack from 2° to 17° . Second, when the rotor blade is fixed at a mean angle of attack of 9.4° . Figure 7 clearly shows that in case of a varying angle of attack, the lift generated on the blade is much more uniform as compared to the case of a fixed angle of attack.

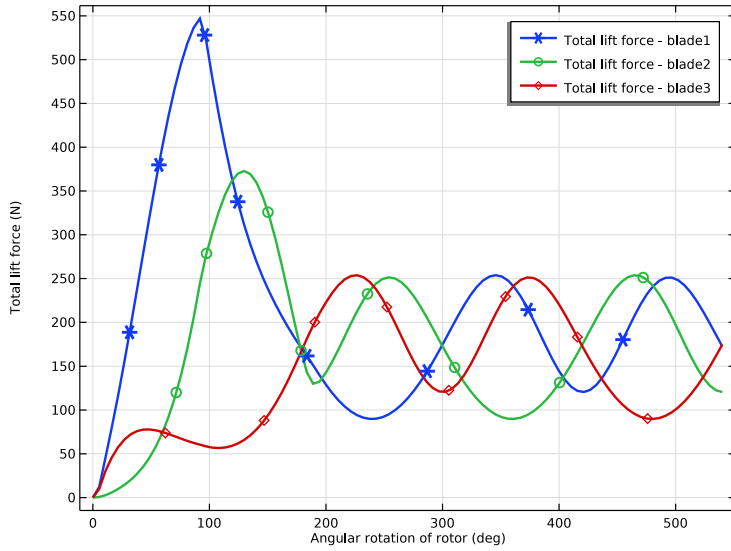

Figure 6: Variation of the total lift force on each rotor blade (rigid case).

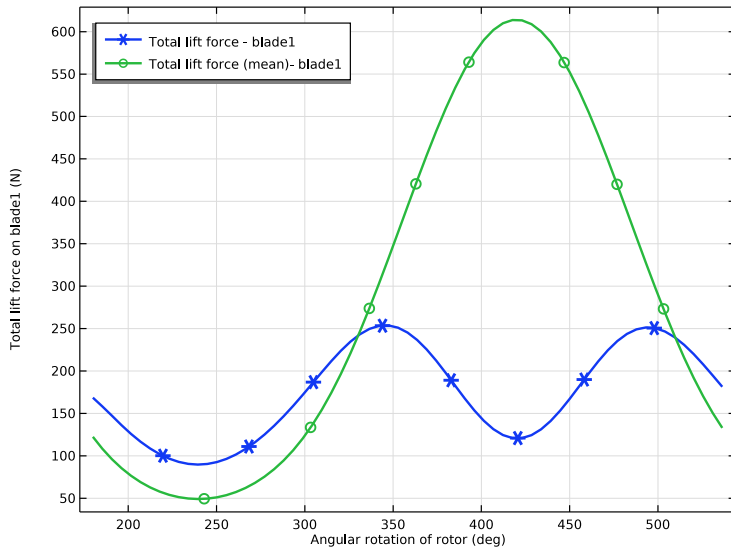

Figure 7: Comparison of the total lift force on the first blade (rigid case).

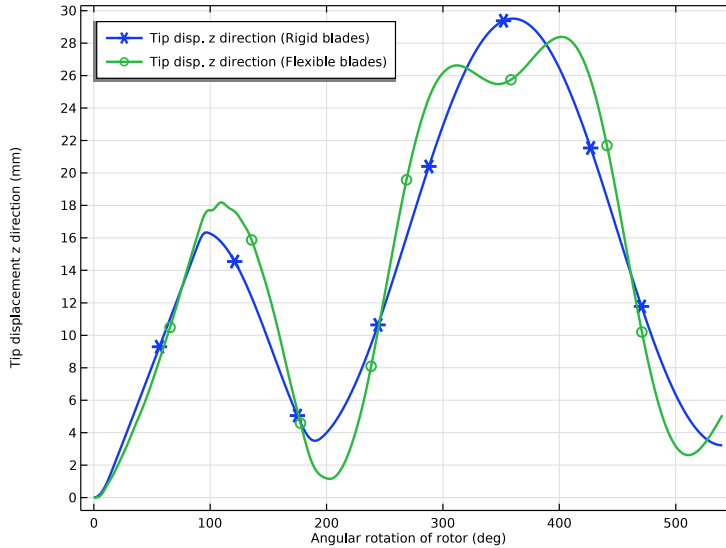

Figure 8: Variation of the z-displacement of the tip for the second blade.

The variation of the tip displacement of the rotor blade in the z direction is shown in Figure 8. The tip displacement is shown for both rigid and flexible blades. In the case of rigid blades, the tip moves in the z direction due to the change in the angle of attack. However, in the case of flexible blades, they also deform.

Figure 9 shows the in-plane deformation of the flexible rotor blade at $t = 0.3$ sec. The deformation is plotted with respect to a reference frame defined by an attachment at the base of the blade. For better visualization, the deformation is scaled by a factor of 50. This in-plane deformation of the flexible blades is often referred to as the *lead-lag phenomenon*.

Figure 10 shows the out-of-plane deformation of the flexible rotor blade at $t = 0.3$ sec. The deformation is also scaled by a factor of 50. The out-of-plane deformation of the flexible blades is called the *flapping phenomenon*. Figure 11 shows the distribution of the von Mises stress in the flexible rotor blade at $t = 0.3$ sec.

The mode shapes of the helicopter swashplate assembly are shown in Figure 12 and Figure 13. The mechanism has three rigid body modes. The first plot shows the 6th mode, which is a bending mode and has its eigenfrequency close to 11.76 Hz. The second plot shows the 16th mode, which is a torsion mode with an eigenfrequency close to 181.43 Hz.

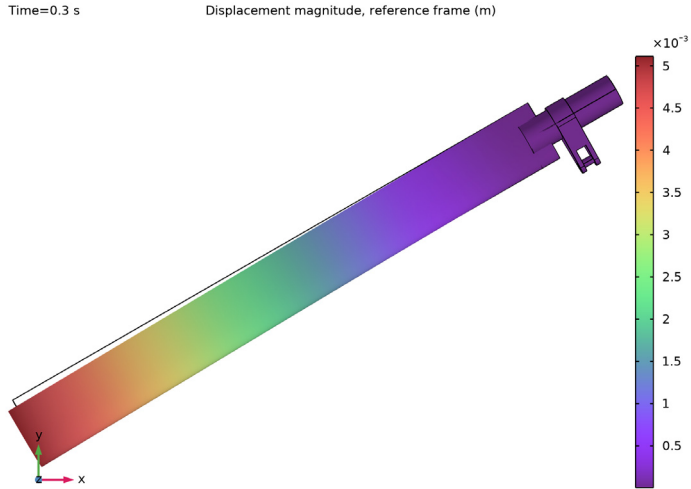

Figure 9: In-plane deformation of the flexible rotor blade at a particular instant (magnified).

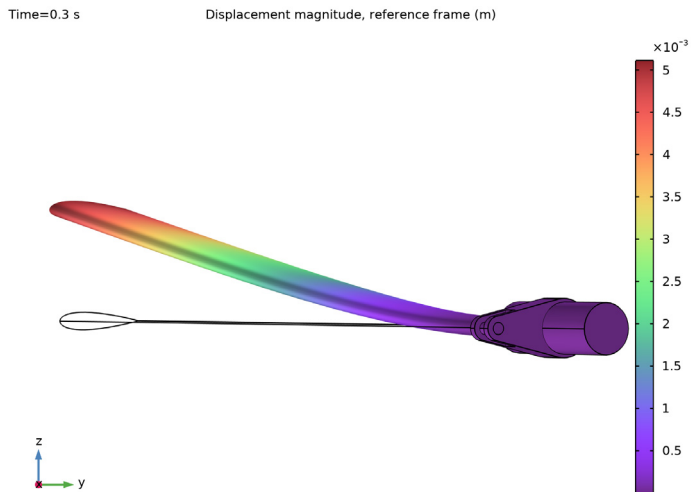

Figure 10: Out-of-plane deformation of the flexible rotor blade at a particular instant (magnified).

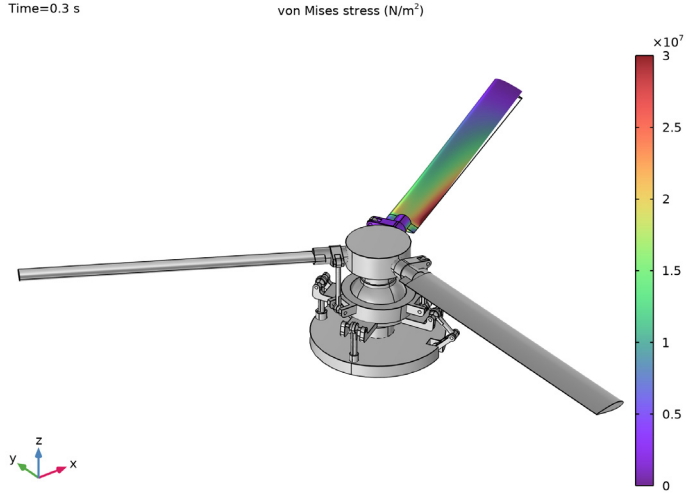

Figure 11: von Mises stress distribution in the flexible rotor blade at a particular instant.

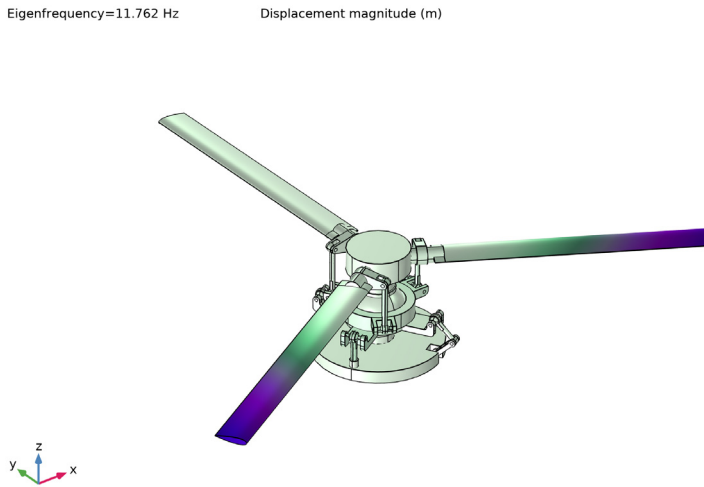

Figure 12: Mode shape of the helicopter washplate mechanism (bending mode).

Eigenfrequency=181.43 Hz

Displacement magnitude (m)

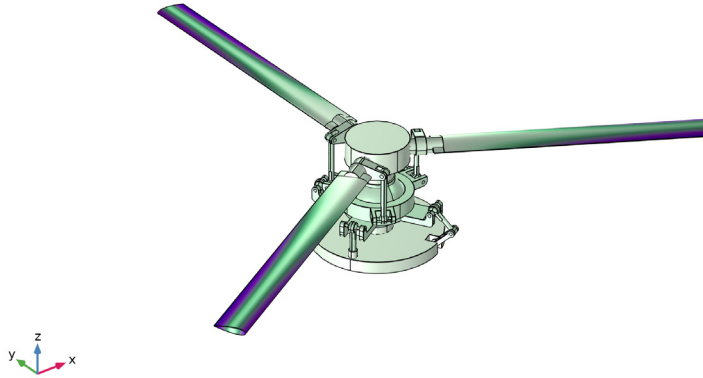

Figure 13: Mode shape of the helicopter swashplate mechanism (torsion mode).

Notes About the COMSOL Implementation

- A **Joint** node can establish a direct connection between **Rigid Material** nodes. However, for flexible elements, **Attachment** nodes are needed to define the connection boundaries.
- Constraint boundary conditions like **Rigid Connector** and **Prescribed Displacement** cannot be used with a **Rigid Material** node. Hence, the **Prescribed Displacement/Rotation** node (subnode to **Rigid Material**) is used to constrain or prescribe the corresponding degrees of freedom.
- The connections set up in the model can be reviewed in the **Joints Summary** section at the physics node.
- Both the geometry and mesh have been built using COMSOL Multiphysics. However, the meshed geometry is imported to simplify the modeling.
- To recompute study-1 in the saved model, make the changes given at the end of the document.

Application Library path: Multibody_Dynamics_Module/
Automotive_and_Aerospace/helicopter_swashplate



Modeling Instructions

From the **File** menu, choose **New**.

NEW

In the **New** window, click  **Model Wizard**.



MODEL WIZARD

- 1 In the **Model Wizard** window, click .
- 2 In the **Select Physics** tree, select **Structural Mechanics > Multibody Dynamics (mbd)**.
- 3 Click **Add**.
- 4 Click  **Study**.
- 5 In the **Select Study** tree, select **General Studies > Time Dependent**.
- 6 Click  **Done**.

Import the meshed geometry of the helicopter swashplate mechanism to save modeling time.

MESH 1

Import 1

- 1 In the **Mesh** toolbar, click  **Import**.
- 2 In the **Settings** window for **Import**, locate the **Import** section.
- 3 Click  **Browse**.
- 4 Browse to the model's Application Libraries folder and double-click the file `helicopter_swashplate.mphbin`.
- 5 Click  **Import**.

Information

Click the  **Zoom Extents** button in the **Graphics** toolbar.

Define variables and functions to use when setting up the physics.

GLOBAL DEFINITIONS

Use ramp functions to specify the motion of the pushrods.

Ramp 1 (rm1)

- 1 In the **Home** toolbar, click  **Functions** and choose **Global > Ramp**.
- 2 In the **Settings** window for **Ramp**, locate the **Parameters** section.

- 3 In the **Location** text field, type 0.002[s].
- 4 Select the **Cutoff** checkbox. In the associated text field, type 0.05[s].
- 5 Click to expand the **Smoothing** section.
- 6 Select the **Size of transition zone at start** checkbox. In the associated text field, type 0.005.
- 7 Select the **Size of transition zone at cutoff** checkbox. In the associated text field, type 0.005.

Ramp 2 (rm2)

- 1 Right-click **Ramp 1 (rm1)** and choose **Duplicate**.
- 2 In the **Settings** window for **Ramp**, locate the **Parameters** section.
- 3 In the **Location** text field, type 0.004[s].
- 4 In the **Cutoff** text field, type 0.1[s].
- 5 Locate the **Smoothing** section. In the **Size of transition zone at start** text field, type 0.01.
- 6 In the **Size of transition zone at cutoff** text field, type 0.01.

Variables 1

- 1 In the **Home** toolbar, click  **Variables** and choose **Global Variables**.
- 2 In the **Settings** window for **Variables**, locate the **Variables** section.
- 3 In the table, enter the following settings:

Name	Expression	Unit	Description
vf	100[km/h]	m/s	Forward speed of helicopter
rpm	300		RPM of helicopter rotor
omega	$2*\pi*rpm/60[s]$	l/s	Angular velocity of rotor
theta	$omega*t[rad]$	rad	Angular rotation of rotor
vp	0.5[m/s]	m/s	Speed of pushrod motion
up1	$vp*rm1(t)$	m	Motion of pushrod 1 and 3
up2	$vp*rm2(t)$	m	Motion of pushrod 2

Create selections to define the rotor blades. Either select any entity directly from the geometry or alternatively type entity number using the **Paste Selection** option.

DEFINITIONS

Blade 1

- 1 In the **Definitions** toolbar, click  **Explicit**.

- 2 In the **Settings** window for **Explicit**, type Blade1 in the **Label** text field.
- 3 Select Domains 1, 2, 4, 5, 8–10, and 12 only.



Blade2

- 1 In the **Definitions** toolbar, click  **Explicit**.
- 2 In the **Settings** window for **Explicit**, type Blade2 in the **Label** text field.
- 3 Select Domains 17, 19–24, and 26 only.



Blade3

- 1 In the **Definitions** toolbar, click  **Explicit**.
- 2 In the **Settings** window for **Explicit**, type Blade3 in the **Label** text field.
- 3 Select Domains 25, 29–33, 36, and 37 only.



Blades

- 1 In the **Definitions** toolbar, click  **Union**.
- 2 In the **Settings** window for **Union**, type Blades in the **Label** text field.
- 3 Locate the **Input Entities** section. Under **Selections to add**, click  **Add**.
- 4 In the **Add** dialog, in the **Selections to add** list, choose **Blade1**, **Blade2**, and **Blade3**.
- 5 Click **OK**.

Without Blades

- 1 In the **Definitions** toolbar, click  **Complement**.
- 2 In the **Settings** window for **Complement**, type Without Blades in the **Label** text field.
- 3 Locate the **Input Entities** section. Under **Selections to invert**, click  **Add**.
- 4 In the **Add** dialog, select **Blade1** in the **Selections to invert** list.
- 5 Click **OK**.

ADD MATERIAL

- 1 In the **Materials** toolbar, click  **Add Material** to open the **Add Material** window.
- 2 Go to the **Add Material** window.
- 3 In the tree, select **Built-in** > **Structural steel**.
- 4 Click the **Add to Component** button in the window toolbar.
- 5 In the **Materials** toolbar, click  **Add Material** to close the **Add Material** window.

MULTIBODY DYNAMICS (MBD)

Define the initial angular velocity at the physics node to use for the rotating parts of the mechanism to avoid transient effects.

- 1 In the **Settings** window for **Multibody Dynamics**, click to expand the **Initial Values** section.
- 2 Specify the ω vector as

0	x
0	y
omega	z

Rigid Material: Baseplate

- 1 In the **Physics** toolbar, click  **Domains** and choose **Rigid Material**.
- 2 In the **Settings** window for **Rigid Material**, type Rigid Material: Baseplate in the **Label** text field.
- 3 Select Domain 7 only.
Set the initial values of the nonrotating parts to zero locally.
- 4 Locate the **Initial Values** section. From the list, choose **Locally defined**.

Fixed Constraint 1

In the **Physics** toolbar, click  **Attributes** and choose **Fixed Constraint**.

Rigid Material: Pushrod 1

- 1 In the **Physics** toolbar, click  **Domains** and choose **Rigid Material**.
- 2 In the **Settings** window for **Rigid Material**, type Rigid Material: Pushrod1 in the **Label** text field.
- 3 Select Domain 6 only.
- 4 Locate the **Initial Values** section. From the list, choose **Locally defined**.

Rigid Materials (Stationary)

Create all similar parts by duplicating the **Rigid Material 2** node and changing the settings of the nodes according to the table below.

Name	Selection
Rigid Material: Pushrod2	13
Rigid Material: Pushrod3	35
Rigid Material: Baseplate-Swashplate Link1	27

Name	Selection
Rigid Material: Baseplate-Swashplate Link2	28
Rigid Material: Lower Swashplate	3

Rigid Material: Rotor Hub

- 1 In the **Physics** toolbar, click  **Domains** and choose **Rigid Material**.
- 2 In the **Settings** window for **Rigid Material**, type Rigid Material: Rotor Hub in the **Label** text field.
- 3 Select Domain 14 only.

Prescribed Displacement/Rotation 1

- 1 In the **Physics** toolbar, click  **Attributes** and choose **Prescribed Displacement/Rotation**.
- 2 In the **Settings** window for **Prescribed Displacement/Rotation**, locate the **Center of Rotation** section.
- 3 From the list, choose **User defined**.
- 4 Locate the **Prescribed Displacement at Center of Rotation** section. Select the **Prescribed in x direction** checkbox.
- 5 Select the **Prescribed in y direction** checkbox.
- 6 Select the **Prescribed in z direction** checkbox.
- 7 Locate the **Prescribed Rotation** section. From the **By** list, choose **Prescribed rotation**.
- 8 Specify the Ω vector as

0	x
0	y
1	z

- 9 In the ϕ_0 text field, type theta.

Rigid Material: Upper Swashplate

- 1 In the **Physics** toolbar, click  **Domains** and choose **Rigid Material**.
- 2 In the **Settings** window for **Rigid Material**, type Rigid Material: Upper Swashplate in the **Label** text field.
- 3 Select Domain 11 only.

Rigid Materials (Rotating)

Create all similar parts using the information given in the table:

Name	Selection
Rigid Material: Sphere	18
Rigid Material: Swashplate-Blade Link1	16
Rigid Material: Swashplate-Blade Link2	15
Rigid Material: Swashplate-Blade Link3	34
Rigid Material: Rotor Blade1	Blade 1
Rigid Material: Rotor Blade2	Blade 2
Rigid Material: Rotor Blade2	Blade 3

Create attachments to set up the connection for the case of flexible rotor blades.

Attachment: Swashplate-Blade 1

- 1 In the **Physics** toolbar, click  **Boundaries** and choose **Attachment**.
- 2 In the **Settings** window for **Attachment**, type Attachment: Swashplate-Blade1 in the **Label** text field.
- 3 Select Boundaries 265, 266, 290, and 291 only.

Attachments

You can create more attachments using the information given in the table below.

Name	Selection
Attachment: Swashplate-Blade2	313, 314, 340, 341
Attachment: Swashplate-Blade3	687, 688, 695, 696
Attachment: Hub-Blade1	152, 153, 197, 198
Attachment: Hub-Blade2	414, 415, 445, 447
Attachment: Hub-Blade3	470, 471, 480, 482

After creating the different parts of the mechanism, establish connections between them using joint nodes.

Prismatic Joint 1

- 1 In the **Physics** toolbar, click  **Global** and choose **Prismatic Joint**.
- 2 In the **Settings** window for **Prismatic Joint**, locate the **Attachment Selection** section.
- 3 From the **Source** list, choose **Rigid Material: Baseplate**.
- 4 From the **Destination** list, choose **Rigid Material: Pushrod 1**.

- 5 Locate the **Center of Joint** section. From the **Entity level** list, choose **Point**.
- 6 Locate the **Axis of Joint** section. Specify the \mathbf{e}_0 vector as

0	x
0	y
1	z

Center of Joint: Point 1

- 1 In the **Model Builder** window, click **Center of Joint: Point 1**.
- 2 Select Points 48 and 107 only.

Prismatic Joint 1

In the **Model Builder** window, click **Prismatic Joint 1**.

Prescribed Motion 1

- 1 In the **Physics** toolbar, click  **Attributes** and choose **Prescribed Motion**.
- 2 In the **Settings** window for **Prescribed Motion**, locate the **Prescribed Translational Motion** section.
- 3 In the u_p text field, type up1.

The **Reduced Slot** joint is used between the second pushrod and the baseplate to provide the tilting freedom to the swashplate assembly.

Reduced Slot Joint 1

- 1 In the **Physics** toolbar, click  **Global** and choose **Reduced Slot Joint**.
- 2 In the **Settings** window for **Reduced Slot Joint**, locate the **Attachment Selection** section.
- 3 From the **Source** list, choose **Rigid Material: Baseplate**.
- 4 From the **Destination** list, choose **Rigid Material: Pushrod2**.
- 5 Locate the **Center of Joint** section. From the **Entity level** list, choose **Point**.
- 6 Locate the **Axes of Joint** section. From the **Joint translational axis** list, choose **Attached on source**.
- 7 Specify the \mathbf{e}_{tr0} vector as

0	x
0	y
1	z

8 Specify the $\mathbf{e}_{\text{rot}0}$ vector as

$\cos(\pi/6)$	x
$\sin(\pi/6)$	y
0	z

Center of Joint: Point 1

1 In the **Model Builder** window, click **Center of Joint: Point 1**.

2 Select Points 197, 248, 274, and 378 only.

Reduced Slot Joint 1

In the **Model Builder** window, click **Reduced Slot Joint 1**.

Prescribed Motion 1

1 In the **Physics** toolbar, click  **Attributes** and choose **Prescribed Motion**.

2 In the **Settings** window for **Prescribed Motion**, locate the **Prescribed Translational Motion** section.

3 In the u_p text field, type up2.

4 Locate the **Prescribed Rotational Motion** section. From the **Activation condition** list, choose **Never active**.

Prismatic Joint 2

1 In the **Physics** toolbar, click  **Global** and choose **Prismatic Joint**.

2 In the **Settings** window for **Prismatic Joint**, locate the **Attachment Selection** section.

3 From the **Source** list, choose **Rigid Material: Baseplate**.

4 From the **Destination** list, choose **Rigid Material: Pushrod3**.

5 Locate the **Center of Joint** section. From the **Entity level** list, choose **Point**.

6 Locate the **Axis of Joint** section. Specify the \mathbf{e}_0 vector as

0	x
0	y
1	z

Center of Joint: Point 1

1 In the **Model Builder** window, click **Center of Joint: Point 1**.

2 Select Points 1115 and 1219 only.

Prismatic Joint 2

In the **Model Builder** window, click **Prismatic Joint 2**.

Prescribed Motion 1

- 1 In the **Physics** toolbar, click  **Attributes** and choose **Prescribed Motion**.
- 2 In the **Settings** window for **Prescribed Motion**, locate the **Prescribed Translational Motion** section.
- 3 In the u_p text field, type up1.

Hinge Joint 1

- 1 In the **Physics** toolbar, click  **Global** and choose **Hinge Joint**.
- 2 In the **Settings** window for **Hinge Joint**, locate the **Attachment Selection** section.
- 3 From the **Source** list, choose **Rigid Material: Baseplate**.
- 4 From the **Destination** list, choose **Rigid Material: Baseplate-Swashplate Link1**.
- 5 Locate the **Center of Joint** section. From the **Entity level** list, choose **Point**.
- 6 Locate the **Axis of Joint** section. From the list, choose **Select a parallel edge**.

Center of Joint: Point 1

- 1 In the **Model Builder** window, click **Center of Joint: Point 1**.
- 2 Select Points 757, 774, 863, and 896 only.

Joint Axis 1

- 1 In the **Model Builder** window, click **Joint Axis 1**.
- 2 Select Edge 1236 only.

Hinge Joint 2

- 1 In the **Physics** toolbar, click  **Global** and choose **Hinge Joint**.
- 2 In the **Settings** window for **Hinge Joint**, locate the **Attachment Selection** section.
- 3 From the **Source** list, choose **Rigid Material: Baseplate-Swashplate Link1**.
- 4 From the **Destination** list, choose **Rigid Material: Baseplate-Swashplate Link2**.
- 5 Locate the **Center of Joint** section. From the **Entity level** list, choose **Point**.
- 6 Locate the **Axis of Joint** section. From the list, choose **Select a parallel edge**.

Center of Joint: Point 1

- 1 In the **Model Builder** window, click **Center of Joint: Point 1**.
- 2 Select Points 914, 930, 980, and 996 only.

Joint Axis 1

- 1 In the **Model Builder** window, click **Joint Axis 1**.
- 2 Select Edge 1509 only.

Ball Joint 1

- 1 In the **Physics** toolbar, click  **Global** and choose **Ball Joint**.
- 2 In the **Settings** window for **Ball Joint**, locate the **Attachment Selection** section.
- 3 From the **Source** list, choose **Rigid Material: Pushrod 1**.
- 4 From the **Destination** list, choose **Rigid Material: Lower Swashplate**.
- 5 Locate the **Center of Joint** section. From the **Entity level** list, choose **Point**.

Center of Joint: Point 1

- 1 In the **Model Builder** window, click **Center of Joint: Point 1**.
- 2 Select Points 73 and 75 only.

Ball Joints

Create all similar connections by duplicating the above joint with the information given in the table below.

Name	Source	Destination	Center of Joint Selection (points)
Ball joint 2	Rigid Material: Pushrod 2	Rigid Material: Lower Swashplate	263, 265
Ball joint 3	Rigid Material: Pushrod 3	Rigid Material: Lower Swashplate	1062, 1240
Ball joint 4	Rigid Material: Baseplate-Swashplate Link2	Rigid Material: Lower Swashplate	798, 834
Ball joint 5	Rigid Material: Sphere	Rigid Material: Lower Swashplate	558, 723
Ball joint 6	Rigid Material: Upper Swashplate	Rigid Material: Swashplate-Blade Link1	337, 490
Ball joint 7	Rigid Material: Upper Swashplate	Rigid Material: Swashplate-Blade Link2	342, 491
Ball joint 8	Rigid Material: Upper Swashplate	Rigid Material: Swashplate-Blade Link3	993, 1208

Planar Joint 1

- 1 In the **Physics** toolbar, click  **Global** and choose **Planar Joint**.
- 2 In the **Settings** window for **Planar Joint**, locate the **Attachment Selection** section.

- 3 From the **Source** list, choose **Rigid Material: Lower Swashplate**.
- 4 From the **Destination** list, choose **Rigid Material: Upper Swashplate**.
- 5 Locate the **Center of Joint** section. From the list, choose **User defined**.
- 6 Locate the **Axis of Joint** section. Specify the \mathbf{e}_0 vector as

0	x
0	y
1	z

Cylindrical Joint 1

- 1 In the **Physics** toolbar, click  **Global** and choose **Cylindrical Joint**.
- 2 In the **Settings** window for **Cylindrical Joint**, locate the **Attachment Selection** section.
- 3 From the **Source** list, choose **Rigid Material: Sphere**.
- 4 From the **Destination** list, choose **Rigid Material: Rotor Hub**.
- 5 Locate the **Center of Joint** section. From the list, choose **User defined**.
- 6 Locate the **Axis of Joint** section. Specify the \mathbf{e}_0 vector as

0	x
0	y
1	z

Prescribed Motion 1

- 1 In the **Physics** toolbar, click  **Attributes** and choose **Prescribed Motion**.
- 2 In the **Settings** window for **Prescribed Motion**, locate the **Prescribed Translational Motion** section.
- 3 From the **Activation condition** list, choose **Never active**.

Hinge Joint 3

- 1 In the **Physics** toolbar, click  **Global** and choose **Hinge Joint**.
- 2 In the **Settings** window for **Hinge Joint**, locate the **Attachment Selection** section.
- 3 From the **Source** list, choose **Rigid Material: Swashplate-Blade Link I**.
- 4 From the **Destination** list, choose **Attachment: Swashplate-Blade I**.
- 5 Locate the **Axis of Joint** section. From the list, choose **Select a parallel edge**.

Joint Axis 1

- 1 In the **Model Builder** window, click **Joint Axis 1**.

2 Select Edge 551 only.

Hinge Joints

1 Create all similar connections by duplicating the above joint and using the information given in the table below.

Name	Source	Destination	Joint Axis (Edge)
Hinge Joint 4	Rigid Material: Swashplate-Blade Link2	Attachment: Swashplate-Blade2	660
Hinge Joint 5	Rigid Material: Swashplate-Blade Link3	Attachment: Swashplate-Blade3	1681
Hinge Joint 6	Rigid Material: Rotor Hub	Attachment: Hub-Blade1	535
Hinge Joint 7	Rigid Material: Rotor Hub	Attachment: Hub-Blade2:	1053
Hinge Joint 8	Rigid Material: Rotor Hub	Attachment: Hub-Blade3	1144

All connections are summarized in the **Joints Summary** section of the physics node.

Define the angle-of-attack of each rotor blade using joint variables.

DEFINITIONS

Variables 2

- 1 In the **Definitions** toolbar, click **a= Local Variables**.
- 2 In the **Settings** window for **Variables**, locate the **Geometric Entity Selection** section.
- 3 From the **Geometric entity level** list, choose **Domain**.
- 4 From the **Selection** list, choose **Blade1**.
- 5 Locate the **Variables** section. In the table, enter the following settings:

Name	Expression	Unit	Description
alpha	-mbd.hgj6.th	rad	Angle of attack

Variables 3

- 1 In the **Definitions** toolbar, click **a= Local Variables**.
- 2 In the **Settings** window for **Variables**, locate the **Geometric Entity Selection** section.

- 3 From the **Geometric entity level** list, choose **Domain**.
- 4 From the **Selection** list, choose **Blade2**.
- 5 Locate the **Variables** section. In the table, enter the following settings:

Name	Expression	Unit	Description
alpha	mbd.hgj7.th	rad	Angle of attack

Variables 4

- 1 In the **Definitions** toolbar, click  **Local Variables**.
- 2 In the **Settings** window for **Variables**, locate the **Geometric Entity Selection** section.
- 3 From the **Geometric entity level** list, choose **Domain**.
- 4 From the **Selection** list, choose **Blade3**.
- 5 Locate the **Variables** section. In the table, enter the following settings:

Name	Expression	Unit	Description
alpha	mbd.hgj8.th	rad	Angle of attack

Define nonlocal integration couplings to use for computing the total lift force on each rotor blade and the tip displacement of the second rotor blade.

Integration 1 (intop1)

- 1 In the **Definitions** toolbar, click  **Nonlocal Couplings** and choose **Integration**.
- 2 In the **Settings** window for **Integration**, locate the **Source Selection** section.
- 3 From the **Geometric entity level** list, choose **Boundary**.
- 4 Select Boundary 3 only.
- 5 Locate the **Advanced** section. From the **Frame** list, choose **Material (X, Y, Z)**.

Integration 2 (intop2)

- 1 Right-click **Integration 1 (intop1)** and choose **Duplicate**.
- 2 In the **Settings** window for **Integration**, locate the **Source Selection** section.
- 3 Click  **Clear Selection**.
- 4 Select Boundary 400 only.

Integration 3 (intop3)

- 1 Right-click **Integration 2 (intop2)** and choose **Duplicate**.
- 2 In the **Settings** window for **Integration**, locate the **Source Selection** section.
- 3 Click  **Clear Selection**.

4 Select Boundary 714 only.

Integration 4 (intop4)

- 1 Right-click **Integration 3 (intop3)** and choose **Duplicate**.
- 2 In the **Settings** window for **Integration**, locate the **Source Selection** section.
- 3 From the **Geometric entity level** list, choose **Point**.
- 4 Select Point 580 only.

Variables 5

- 1 In the **Definitions** toolbar, click  **Local Variables**.
- 2 In the **Settings** window for **Variables**, locate the **Variables** section.
- 3 In the table, enter the following settings:

Name	Expression	Unit	Description
d	$\sqrt{x^2+y^2}$	m	Distance from the center
Ur	$\omega*d - v_f*y/d$	m/s	Relative velocity
CL	$4*\alpha$	rad	Lift coefficient
FL	$0.5*1[\text{kg}/\text{m}^3]*\text{Ur}^2*CL*\text{sign}(\text{Ur})$	Pa	Lift force
FL_tot1	intop1(FL)	N	Total lift force - blade1
FL_tot2	intop2(FL)	N	Total lift force - blade2
FL_tot3	intop3(FL)	N	Total lift force - blade3
alphaM	9.4[deg]	rad	Mean angle of attack
CL_alphaM	$4*\alpha_M$	rad	Mean lift coefficient
FL_tot1_alphaM	intop1($0.5*1[\text{kg}/\text{m}^3]*\text{Ur}^2*CL_alphaM*\text{sign}(\text{Ur})$)	N	Total lift force (mean)- blade1
w_tip	intop4(w)	m	Tip displacement z direction

Apply the lift force on the rotor blades using a Boundary Load node.

MULTIBODY DYNAMICS (MBD)

Boundary Load 1

- 1 In the **Physics** toolbar, click  **Boundaries** and choose **Boundary Load**.

- 2 Select Boundaries 3, 400, and 714 only.
- 3 In the **Settings** window for **Boundary Load**, locate the **Force** section.
- 4 Specify the \mathbf{f}_A vector as

0	x
0	y
FL	z

To create node groups for the physics features, do the following:

Rigid Material: Baseplate, Rigid Material: Baseplate-Swashplate Link1, Rigid Material: Baseplate-Swashplate Link2, Rigid Material: Lower Swashplate, Rigid Material: Pushrod1, Rigid Material: Pushrod2, Rigid Material: Pushrod3, Rigid Material: Rotor Blade1, Rigid Material: Rotor Blade2, Rigid Material: Rotor Blade3, Rigid Material: Rotor Hub, Rigid Material: Sphere, Rigid Material: Swashplate-Blade Link1, Rigid Material: Swashplate-Blade Link2, Rigid Material: Swashplate-Blade Link3, Rigid Material: Upper Swashplate

- 1 In the **Model Builder** window, under **Component 1 (comp1) > Multibody Dynamics (mbd)**, Ctrl-click to select **Rigid Material: Baseplate, Rigid Material: Pushrod1, Rigid Material: Pushrod2, Rigid Material: Pushrod3, Rigid Material: Baseplate-Swashplate Link1, Rigid Material: Baseplate-Swashplate Link2, Rigid Material: Lower Swashplate, Rigid Material: Rotor Hub, Rigid Material: Upper Swashplate, Rigid Material: Sphere, Rigid Material: Swashplate-Blade Link1, Rigid Material: Swashplate-Blade Link2, Rigid Material: Swashplate-Blade Link3, Rigid Material: Rotor Blade1, Rigid Material: Rotor Blade2, and Rigid Material: Rotor Blade3.**
- 2 Right-click and choose **Group**.

Rigid Materials

In the **Settings** window for **Group**, type Rigid Materials in the **Label** text field.

Attachment: Hub-Blade1, Attachment: Hub-Blade2, Attachment: Hub-Blade3, Attachment: Swashplate-Blade1, Attachment: Swashplate-Blade2, Attachment: Swashplate-Blade3

- 1 In the **Model Builder** window, under **Component 1 (comp1) > Multibody Dynamics (mbd)**, Ctrl-click to select **Attachment: Swashplate-Blade1, Attachment: Swashplate-Blade2, Attachment: Swashplate-Blade3, Attachment: Hub-Blade1, Attachment: Hub-Blade2, and Attachment: Hub-Blade3.**
- 2 Right-click and choose **Group**.

Attachments

In the **Settings** window for **Group**, type Attachments in the **Label** text field.

Prismatic Joint 1, Prismatic Joint 2

- 1 In the **Model Builder** window, under **Component 1 (comp1) > Multibody Dynamics (mbd)**, Ctrl-click to select **Prismatic Joint 1** and **Prismatic Joint 2**.
- 2 Right-click and choose **Group**.

Prismatic Joints

In the **Settings** window for **Group**, type Prismatic Joints in the **Label** text field.

Hinge Joint 1, Hinge Joint 2, Hinge Joint 3, Hinge Joint 4, Hinge Joint 5, Hinge Joint 6, Hinge Joint 7, Hinge Joint 8

- 1 In the **Model Builder** window, under **Component 1 (comp1) > Multibody Dynamics (mbd)**, Ctrl-click to select **Hinge Joint 1, Hinge Joint 2, Hinge Joint 3, Hinge Joint 4, Hinge Joint 5, Hinge Joint 6, Hinge Joint 7, and Hinge Joint 8**.
- 2 Right-click and choose **Group**.

Hinge Joints

In the **Settings** window for **Group**, type Hinge Joints in the **Label** text field.

Ball Joint 1, Ball Joint 2, Ball Joint 3, Ball Joint 4, Ball Joint 5, Ball Joint 6, Ball Joint 7, Ball Joint 8

- 1 In the **Model Builder** window, under **Component 1 (comp1) > Multibody Dynamics (mbd)**, Ctrl-click to select **Ball Joint 1, Ball Joint 2, Ball Joint 3, Ball Joint 4, Ball Joint 5, Ball Joint 6, Ball Joint 7, and Ball Joint 8**.
- 2 Right-click and choose **Group**.

Ball Joints



In the **Settings** window for **Group**, type Ball Joints in the **Label** text field.

STUDY 1

Step 1: Time Dependent

- 1 In the **Model Builder** window, under **Study 1** click **Step 1: Time Dependent**.
- 2 In the **Settings** window for **Time Dependent**, locate the **Study Settings** section.
- 3 In the **Output times** text field, type range (0,0.001,0.3).
- 4 In the **Model Builder** window, click **Study 1**.
- 5 In the **Settings** window for **Study**, type Study: Rigid Blades in the **Label** text field.

Solution 1 (sol1)

- 1 In the **Study** toolbar, click  **Show Default Solver**.
- 2 In the **Model Builder** window, expand the **Solution 1 (sol1)** node.
- 3 In the **Model Builder** window, under **Study: Rigid Blades > Solver Configurations > Solution 1 (sol1)** click **Time-Dependent Solver 1**.
- 4 In the **Settings** window for **Time-Dependent Solver**, click to expand the **Time Stepping** section.
- 5 From the **Steps taken by solver** list, choose **Intermediate**.
- 6 In the **Study** toolbar, click  **Compute**.



Now you can add a new study for performing the transient analysis with flexible blades.

For viewing the motion of the blades with respect to a reference frame, use the option of defining a reference frame available in the **Multibody Dynamics** interface and plot the postprocessing variables with respect to the reference frame.

MULTIBODY DYNAMICS (MBD)

- 1 In the **Model Builder** window, under **Component 1 (comp1)** click **Multibody Dynamics (mbd)**.
- 2 In the **Settings** window for **Multibody Dynamics**, click to expand the **Results** section.
- 3 From the **Body defining reference frame** list, choose **Attachment: Hub-Blade1**.

ADD STUDY

- 1 In the **Home** toolbar, click  **Add Study** to open the **Add Study** window.
- 2 Go to the **Add Study** window.
- 3 Find the **Studies** subsection. In the **Select Study** tree, select **General Studies > Time Dependent**.
- 4 Click the **Add Study** button in the window toolbar.
- 5 In the **Home** toolbar, click  **Add Study** to close the **Add Study** window.



STUDY 2

Step 1: Time Dependent

- 1 In the **Settings** window for **Time Dependent**, locate the **Study Settings** section.
- 2 In the **Output times** text field, type range (0,0.001,0.3).
- 3 Locate the **Physics and Variables Selection** section. Select the **Modify model configuration for study step** checkbox.

- 4 In the tree, select **Component 1 (comp1) > Multibody Dynamics (mbd), Controls spatial frame > Rigid Materials > Rigid Material: Rotor Blade1, Component 1 (comp1) > Multibody Dynamics (mbd), Controls spatial frame > Rigid Materials > Rigid Material: Rotor Blade2, and Component 1 (comp1) > Multibody Dynamics (mbd), Controls spatial frame > Rigid Materials > Rigid Material: Rotor Blade3.**
- 5 Right-click and choose **Disable**.
- 6 In the **Model Builder** window, click **Study 2**.
- 7 In the **Settings** window for **Study**, type Study: Flexible Blades in the **Label** text field.
- 8 Locate the **Study Settings** section. Clear the **Generate default plots** checkbox.

Solution 2 (sol2)

- 1 In the **Study** toolbar, click  **Show Default Solver**.
- 2 In the **Model Builder** window, expand the **Solution 2 (sol2)** node.
- 3 In the **Model Builder** window, expand the **Study: Flexible Blades > Solver Configurations > Solution 2 (sol2) > Time-Dependent Solver 1** node, then click **Fully Coupled 1**.
- 4 In the **Settings** window for **Fully Coupled**, click to expand the **Method and Termination** section.
- 5 From the **Stabilization and acceleration** list, choose **Anderson acceleration**.
- 6 In the **Dimension of iteration space** text field, type 5.
- 7 In the **Mixing parameter** text field, type 0.9.
- 8 In the **Study** toolbar, click  **Compute**.

RESULTS

Displacement (mbd)

The default plots show the displacement and velocity profiles in the mechanism.

Follow the instructions to generate the velocity plot shown in [Figure 4](#).

You can also adjust the view for better visualization and use it in the plot.

Velocity (mbd)

- 1 In the **Model Builder** window, click **Velocity (mbd)**.
- 2 In the **Settings** window for **3D Plot Group**, locate the **Plot Settings** section.
- 3 From the **View** list, choose **New view**.
- 4 In the **Velocity (mbd)** toolbar, click  **Plot**.

Create a new dataset to plot the deformation of the flexible rotor blades.

Study: Flexible Blades/Solution 2 (3) (sol2)

- 1 In the **Model Builder** window, expand the **Results > Datasets** node.
- 2 Right-click **Results > Datasets > Study: Flexible Blades/Solution 2 (sol2)** and choose **Duplicate**.

Selection

- 1 In the **Results** toolbar, click  **Attributes** and choose **Selection**.
- 2 In the **Settings** window for **Selection**, locate the **Geometric Entity Selection** section.
- 3 From the **Geometric entity level** list, choose **Domain**.
- 4 From the **Selection** list, choose **Blade I**.

Study: Flexible Blades/Solution 2 (4) (sol2)



In the **Model Builder** window, under **Results > Datasets** right-click **Study: Flexible Blades/Solution 2 (3) (sol2)** and choose **Duplicate**.

Selection

- 1 In the **Model Builder** window, expand the **Study: Flexible Blades/Solution 2 (4) (sol2)** node, then click **Selection**.
- 2 In the **Settings** window for **Selection**, locate the **Geometric Entity Selection** section.
- 3 Click  **Clear Selection**.
- 4 From the **Selection** list, choose **Without Blades**.

Follow the instructions to plot the deformation in the flexible blade as shown in [Figure 9](#) and [Figure 10](#).

Displacement: Flexible Blade I

- 1 In the **Model Builder** window, right-click **Displacement (mbd)** and choose **Duplicate**.
- 2 In the **Settings** window for **3D Plot Group**, type **Displacement: Flexible Blade I** in the **Label** text field.
- 3 Locate the **Data** section. From the **Dataset** list, choose **Study: Flexible Blades/Solution 2 (3) (sol2)**.
- 4 Locate the **Plot Settings** section. From the **Frame** list, choose **Material (X, Y, Z)**.
- 5 Click the  **Zoom Extents** button in the **Graphics** toolbar.
- 6 In the **Displacement: Flexible Blade I** toolbar, click  **Plot**.
Increase the deformation scale factor for better visualization.







Surface

- 1 In the **Model Builder** window, expand the **Displacement: Flexible Blade I** node, then click **Surface**.
- 2 In the **Settings** window for **Surface**, locate the **Expression** section.
- 3 In the **Expression** text field, type `mbd.disp_ref`.

Deformation

- 1 In the **Model Builder** window, expand the **Surface** node, then click **Deformation**.
- 2 In the **Settings** window for **Deformation**, locate the **Expression** section.
- 3 In the **X-component** text field, type `u_ref`.
- 4 In the **Y-component** text field, type `v_ref`.
- 5 In the **Z-component** text field, type `w_ref`.
- 6 Locate the **Scale** section. In the **Scale factor** text field, type 50.

Displacement: Flexible Blade I

- 1 In the **Model Builder** window, under **Results** click **Displacement: Flexible Blade I**.
- 2 In the **Settings** window for **3D Plot Group**, locate the **Plot Settings** section.
- 3 From the **View** list, choose **New view**.
- 4 Click the  **Go to XY View** button in the **Graphics** toolbar.
- 5 Click the  **Zoom Extents** button in the **Graphics** toolbar.
- 6 In the **Displacement: Flexible Blade I** toolbar, click  **Plot**.
- 7 From the **View** list, choose **New view**.
- 8 Click the  **Go to YZ View** button in the **Graphics** toolbar.
- 9 Click the  **Zoom Extents** button in the **Graphics** toolbar.
- 10 In the **Displacement: Flexible Blade I** toolbar, click  **Plot**.

Follow the instructions below to generate the von Mises stress distribution shown in [Figure 11](#).

Stress: Flexible Blade I

- 1 Right-click **Displacement: Flexible Blade I** and choose **Duplicate**.
- 2 In the **Settings** window for **3D Plot Group**, type `Stress: Flexible Blade1` in the **Label** text field.
- 3 Locate the **Data** section. From the **Dataset** list, choose **Study: Flexible Blades/ Solution 2 (2) (sol2)**.
- 4 Locate the **Plot Settings** section. From the **View** list, choose **View 1**.

- 5 From the **Frame** list, choose **Spatial (x, y, z)**.

Surface

- 1 In the **Model Builder** window, expand the **Stress: Flexible Blade I** node, then click **Surface**.
- 2 In the **Settings** window for **Surface**, locate the **Data** section.
- 3 From the **Dataset** list, choose **Study: Flexible Blades/Solution 2 (3) (sol2)**.
- 4 From the **Solution parameters** list, choose **From parent**.
- 5 Locate the **Expression** section. In the **Expression** text field, type `mbd.mises`.
- 6 Click to expand the **Range** section. Select the **Manual color range** checkbox.
- 7 In the **Minimum** text field, type `0`.
- 8 In the **Maximum** text field, type `3e7`.



Deformation

- 1 In the **Model Builder** window, expand the **Surface** node, then click **Deformation**.
- 2 In the **Settings** window for **Deformation**, locate the **Expression** section.
- 3 In the **X-component** text field, type `u`.
- 4 In the **Y-component** text field, type `v`.
- 5 In the **Z-component** text field, type `w+10*w_ref`.
- 6 Locate the **Scale** section. In the **Scale factor** text field, type `1`.

Surface 2

- 1 In the **Model Builder** window, right-click **Surface** and choose **Duplicate**.
- 2 In the **Settings** window for **Surface**, locate the **Data** section.
- 3 From the **Dataset** list, choose **Study: Flexible Blades/Solution 2 (4) (sol2)**.
- 4 Locate the **Expression** section. In the **Expression** text field, type `dom`.
- 5 Click to expand the **Title** section. From the **Title type** list, choose **None**.
- 6 Locate the **Coloring and Style** section. From the **Coloring** list, choose **Uniform**.
- 7 From the **Color** list, choose **Gray**.

Deformation

- 1 In the **Model Builder** window, expand the **Surface 2** node, then click **Deformation**.
- 2 In the **Settings** window for **Deformation**, locate the **Expression** section.
- 3 In the **Z-component** text field, type `w`.
- 4 Click the  **Go to Default View** button in the **Graphics** toolbar.
- 5 Click the  **Zoom Extents** button in the **Graphics** toolbar.

6 In the **Stress: Flexible Blade I** toolbar, click  **Plot**.

To plot the angle of attack variation of rotor blades shown in [Figure 5](#), follow the instructions below.

Angle of Attack

1 In the **Results** toolbar, click  **ID Plot Group**.

2 In the **Settings** window for **ID Plot Group**, type Angle of Attack in the **Label** text field.

Global I

1 Right-click **Angle of Attack** and choose **Global**.

2 In the **Settings** window for **Global**, locate the **y-Axis Data** section.

3 In the table, enter the following settings:

Expression	Unit	Description
-mbd.hgj6.th	deg	Relative rotation
mbd.hgj7.th	deg	Relative rotation
mbd.hgj8.th	deg	Relative rotation

4 Locate the **x-Axis Data** section. From the **Parameter** list, choose **Expression**.

5 In the **Expression** text field, type $\theta * 180 / \pi$.

6 Click to expand the **Coloring and Style** section. From the **Width** list, choose **2**.

7 Find the **Line markers** subsection. From the **Marker** list, choose **Cycle**.

8 From the **Positioning** list, choose **Interpolated**.

9 Click to expand the **Legends** section. From the **Legends** list, choose **Manual**.

10 In the table, enter the following settings:



Legends
Angle of attack: blade1
Angle of attack: blade2
Angle of attack: blade3

Angle of Attack

1 In the **Model Builder** window, click **Angle of Attack**.

2 In the **Settings** window for **ID Plot Group**, locate the **Plot Settings** section.

3 Select the **x-axis label** checkbox. In the associated text field, type Angular rotation of rotor (deg).

- 4 Select the **y-axis label** checkbox. In the associated text field, type Angle of attack (deg).
- 5 Click to expand the **Title** section. From the **Title type** list, choose **None**.
- 6 In the **Angle of Attack** toolbar, click  **Plot**.
- 7 Locate the **Axis** section. Select the **Manual axis limits** checkbox.
- 8 In the **y maximum** text field, type 25.
- 9 In the **Angle of Attack** toolbar, click  **Plot**.

To plot the total lift force on the rotor blades shown in [Figure 6](#), follow the instructions below.

Total Lift Force

- 1 In the **Results** toolbar, click  **ID Plot Group**.
- 2 In the **Settings** window for **ID Plot Group**, type Total Lift Force in the **Label** text field.
- 3 Locate the **Data** section. From the **Time selection** list, choose **Interpolated**.
- 4 In the **Times (s)** text field, type range(0,0.003,0.3).

Global I

- 1 Right-click **Total Lift Force** and choose **Global**.
- 2 In the **Settings** window for **Global**, click **Replace Expression** in the upper-right corner of the **y-Axis Data** section. From the menu, choose **Component I (comp1) > Definitions > Variables > FL_tot1 - Total lift force - blade1 - N**.
- 3 Click **Add Expression** in the upper-right corner of the **y-Axis Data** section. From the menu, choose **Component I (comp1) > Definitions > Variables > FL_tot2 - Total lift force - blade2 - N**.
- 4 Click **Add Expression** in the upper-right corner of the **y-Axis Data** section. From the menu, choose **Component I (comp1) > Definitions > Variables > FL_tot3 - Total lift force - blade3 - N**.
- 5 Locate the **x-Axis Data** section. From the **Parameter** list, choose **Expression**.
- 6 In the **Expression** text field, type $\theta * 180 / \pi$.
- 7 Locate the **Coloring and Style** section. From the **Width** list, choose **2**.
- 8 Find the **Line markers** subsection. From the **Marker** list, choose **Cycle**.
- 9 From the **Positioning** list, choose **Interpolated**.

Total Lift Force

- 1 In the **Model Builder** window, click **Total Lift Force**.

- 2 In the **Settings** window for **ID Plot Group**, locate the **Plot Settings** section.
- 3 Select the **x-axis label** checkbox. In the associated text field, type Angular rotation of rotor (deg).
- 4 Select the **y-axis label** checkbox. In the associated text field, type Total lift force (N).
- 5 Locate the **Title** section. From the **Title type** list, choose **None**.
- 6 In the **Total Lift Force** toolbar, click  **Plot**.

Duplicate the above figure to generate the plot shown in [Figure 7](#).



Total Lift Force: Blade I

- 1 Right-click **Total Lift Force** and choose **Duplicate**.
- 2 In the **Settings** window for **ID Plot Group**, type Total Lift Force: Blade1 in the **Label** text field.
- 3 Locate the **Data** section. In the **Times (s)** text field, type range(0.1,0.003,0.3).

Global I

- 1 In the **Model Builder** window, expand the **Total Lift Force: Blade I** node, then click **Global I**.
- 2 In the **Settings** window for **Global**, click **Replace Expression** in the upper-right corner of the **y-Axis Data** section. From the menu, choose **Component I (comp1) > Definitions > Variables > FL_totI - Total lift force - bladeI - N**.
- 3 Click **Add Expression** in the upper-right corner of the **y-Axis Data** section. From the menu, choose **Component I (comp1) > Definitions > Variables > FL_totI_alphaM - Total lift force (mean)- bladeI - N**.

Total Lift Force: Blade I

- 1 In the **Model Builder** window, click **Total Lift Force: Blade I**.
- 2 In the **Settings** window for **ID Plot Group**, locate the **Plot Settings** section.
- 3 In the **y-axis label** text field, type Total lift force on blade1 (N).
- 4 In the **Total Lift Force: Blade I** toolbar, click  **Plot**.
- 5 Locate the **Legend** section. From the **Position** list, choose **Upper left**.
- 6 In the **Total Lift Force: Blade I** toolbar, click  **Plot**.

Follow the instructions below to generate the tip displacement plot shown in [Figure 8](#).

Tip Displacement

- 1 In the **Results** toolbar, click  **ID Plot Group**.

- 2 In the **Settings** window for **ID Plot Group**, type Tip Displacement in the **Label** text field.

Global 1

- 1 Right-click **Tip Displacement** and choose **Global**.
- 2 In the **Settings** window for **Global**, locate the **Data** section.
- 3 From the **Dataset** list, choose **Study: Rigid Blades/Solution 1 (sol1)**.
- 4 Click **Replace Expression** in the upper-right corner of the **y-Axis Data** section. From the menu, choose **Component 1 (comp1) > Definitions > Variables > w_tip - Tip displacement z direction - m**.
- 5 Locate the **y-Axis Data** section. In the table, enter the following settings:

Expression	Unit	Description
w_tip	mm	Tip displacement z direction

- 6 Locate the **x-Axis Data** section. From the **Parameter** list, choose **Expression**.
- 7 In the **Expression** text field, type $\theta * 180 / \pi$.
- 8 Locate the **Coloring and Style** section. From the **Width** list, choose **2**.
- 9 Find the **Line markers** subsection. From the **Marker** list, choose **Cycle**.
- 10 From the **Positioning** list, choose **Interpolated**.
- 11 Locate the **Legends** section. From the **Legends** list, choose **Manual**.
- 12 In the table, enter the following settings:

Legends
Tip disp. z direction (Rigid blades)

Global 2

- 1 Right-click **Global 1** and choose **Duplicate**.
- 2 In the **Settings** window for **Global**, locate the **Data** section.
- 3 From the **Dataset** list, choose **Study: Flexible Blades/Solution 2 (3) (sol2)**.
- 4 Locate the **Legends** section. In the table, enter the following settings:

Legends
Tip disp. z direction (Flexible blades)



Tip Displacement

- 1 In the **Model Builder** window, click **Tip Displacement**.

- 2 In the **Settings** window for **ID Plot Group**, locate the **Legend** section.
- 3 From the **Position** list, choose **Upper left**.
- 4 Locate the **Title** section. From the **Title type** list, choose **None**.
- 5 Locate the **Plot Settings** section.
- 6 Select the **x-axis label** checkbox. In the associated text field, type Angular rotation of rotor (deg).
- 7 In the **Tip Displacement** toolbar, click  **Plot**.

Add a new study to perform an eigenfrequency analysis of this mechanism with flexible blades.

ADD STUDY

- 1 In the **Home** toolbar, click  **Add Study** to open the **Add Study** window.
- 2 Go to the **Add Study** window.
- 3 Find the **Studies** subsection. In the **Select Study** tree, select **General Studies** > **Eigenfrequency**.
- 4 Click the **Add Study** button in the window toolbar.
- 5 In the **Home** toolbar, click  **Add Study** to close the **Add Study** window.

STUDY 3

Step 1: Eigenfrequency

- 1 In the **Settings** window for **Eigenfrequency**, locate the **Study Settings** section.
- 2 Select the **Desired number of eigenfrequencies** checkbox. In the associated text field, type 20.
- 3 Locate the **Physics and Variables Selection** section. Select the **Modify model configuration for study step** checkbox.
- 4 In the tree, select **Component 1 (comp1)** > **Multibody Dynamics (mbd)** > **Rigid Materials** > **Rigid Material: Rotor Blade1**, **Component 1 (comp1)** > **Multibody Dynamics (mbd)** > **Rigid Materials** > **Rigid Material: Rotor Blade2**, **Component 1 (comp1)** > **Multibody Dynamics (mbd)** > **Rigid Materials** > **Rigid Material: Rotor Blade3**, **Component 1 (comp1)** > **Multibody Dynamics (mbd)** > **Prismatic Joints** > **Prismatic Joint 1** > **Prescribed Motion 1**, **Component 1 (comp1)** > **Multibody Dynamics (mbd)** > **Prismatic Joints** > **Prismatic Joint 2** > **Prescribed Motion 1**, and **Component 1 (comp1)** > **Multibody Dynamics (mbd)** > **Reduced Slot Joint 1** > **Prescribed Motion 1**.
- 5 Right-click and choose **Disable**.

- 6 In the **Model Builder** window, click **Study 3**.
- 7 In the **Settings** window for **Study**, type Study: Flexible Blades[Eigenfrequency] in the **Label** text field.
- 8 In the **Study** toolbar, click  **Compute**.

RESULTS

Mode Shape (mbd)



Follow the instructions below to generate the mode shapes shown in [Figure 12](#) and [Figure 13](#).

- 1 In the **Settings** window for **3D Plot Group**, locate the **Data** section.
- 2 From the **Eigenfrequency (Hz)** list, choose **11.762**.
- 3 In the **Mode Shape (mbd)** toolbar, click  **Plot**.
- 4 In the **Model Builder** window, expand the **Mode Shape (mbd)** node.

Deformation

- 1 In the **Model Builder** window, expand the **Results > Mode Shape (mbd) > Surface** node, then click **Deformation**.
- 2 In the **Settings** window for **Deformation**, locate the **Scale** section.
- 3 Select the **Scale factor** checkbox. In the associated text field, type 0.02.

Mode Shape (mbd)

- 1 In the **Model Builder** window, under **Results** click **Mode Shape (mbd)**.
- 2 In the **Settings** window for **3D Plot Group**, locate the **Plot Settings** section.
- 3 From the **View** list, choose **View 1**.
- 4 In the **Mode Shape (mbd)** toolbar, click  **Plot**.
- 5 Locate the **Data** section. From the **Eigenfrequency (Hz)** list, choose **181.43**.
- 6 In the **Mode Shape (mbd)** toolbar, click  **Plot**.

Finally, generate an animation of the helicopter swashplate mechanism showing the displacement of all the components.

Animation 1

- 1 In the **Results** toolbar, click  **Animation** and choose **Player**.
- 2 In the **Settings** window for **Animation**, locate the **Frames** section.
- 3 In the **Number of frames** text field, type 50.

Animation 2

- 1 Right-click **Animation 1** and choose **Duplicate**.
- 2 In the **Settings** window for **Animation**, locate the **Scene** section.
- 3 From the **Subject** list, choose **Displacement: Flexible Blade I**.

Animation 3

- 1 Right-click **Animation 2** and choose **Duplicate**.
- 2 In the **Settings** window for **Animation**, locate the **Scene** section.
- 3 From the **Subject** list, choose **Stress: Flexible Blade I**.