



Model created in COMSOL Multiphysics 6.4

Shaft Vibration due to Gear Rattle and Bearing Misalignment

Introduction

In a gearbox, vibrations due to gear rattling and bearing misalignment are well known sources of noise. In this example, two shafts connected through a pair of gears are considered. The shafts are supported on roller bearings at their ends. Initially, the driven shaft is unloaded and the driver shaft rotates with a varying speed. Due to backlash, intermittent tooth meshing causes vibrations in the shafts. After some time, a resisting torque is applied to the driven shaft, making the tooth meshing smooth. In order to analyze the effect of bearing misalignment on rotor vibrations, a time-dependent analysis is performed for two cases. In the first case, all bearings are aligned with the shafts, and in the second, one of the bearings (number 2) has a small angular misalignment.

Note: This model requires the Multibody Dynamics Module and the Rotordynamics Module.

Model Definition

The model consists of two shafts connected through a pair of spur gears. The spur gear of the first (driver) shaft transfers rotation to the larger spur gear of the second (driven) shaft. Both shafts are supported at their ends using roller bearings.

The geometry is shown in [Figure 1](#) below.

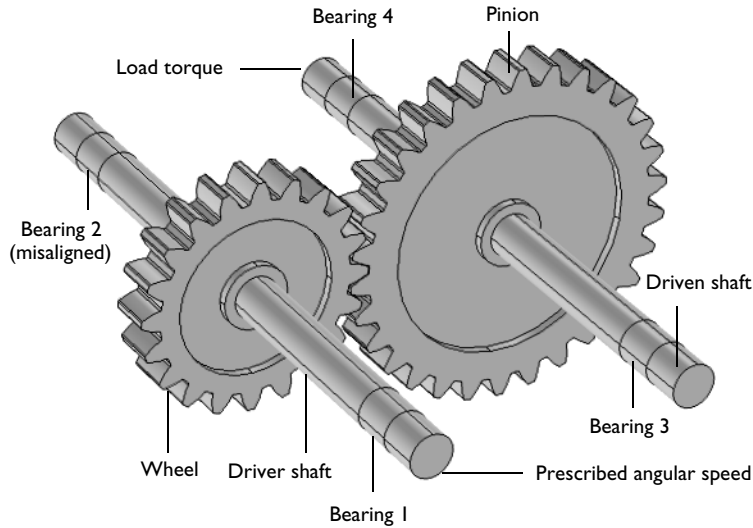

Figure 1: System geometry.

SHAFTS

The shafts are made of structural steel, with diameter and length of 20 mm and 300 mm, respectively. The mean angular speed of the driver shaft is assumed to be $\omega_0 = 20$ rad/s. It fluctuates about this mean speed as:

$$\omega = \omega_0(1 + 0,05 \sin(10\omega_0 t))$$

BEARINGS

Each shaft is supported by deep groove ball bearings at the ends. The bearings have the same dimensions and material properties. The properties are given in [Table 1](#).

TABLE 1: BEARING PROPERTIES.

PROPERTY	VALUE
Number of balls	20
Ball diameter	1.33 mm
Pitch diameter	21.33 mm
Contour radius, inner race	0.7049 mm

TABLE 1: BEARING PROPERTIES.

PROPERTY	VALUE
Contour radius, outer race	0.7049 mm
Young's modulus	200 GPa
Poisson's ratio	0.3

GEARS

The properties of the spur gears are given in [Table 2](#).

TABLE 2: GEAR PROPERTIES.

PROPERTY	VALUE
Number of teeth (Wheel)	20
Pitch diameter (Wheel)	100 mm
Number of teeth (Pinion)	30
Pitch diameter (Pinion)	150 mm
Pressure angle	25°
Gear ratio	1.5
Backlash	1 mm

The density of the gears, used to compute inertial properties, is equal to the shaft density.

CONSTRAINTS AND LOADS

- The axial rotation is prescribed at one end of the driver shaft.
- A resisting load torque of 100 Nm is applied at the opposite end of the driven shaft. The torque is activated only after the driver shaft has completed a 45° rotation.

Results and Discussion

[Figure 2](#) shows the axial stress variation in the shafts. In addition to the torque, there are mainly two forces acting on the shafts. One, a gear mesh force acting in the pressure angle direction which bends the shafts in opposite direction and other the reaction forces from the bearing. Reaction forces in the bearing mainly support the shaft against the gear mesh force. Moreover, due to the angular misalignment in one of the bearings, an additional reaction moment is also present to overcome the misalignment in that bearing. The net axial stress in the shaft will be a combination of the bending of the shaft about two axes, one perpendicular to the pressure angle direction, and the other parallel to the misalignment axis. From the stress distribution in the shafts it is clear that the bending in the shaft due to gear mesh force is larger as compared to the bending due to the bearing

misalignment. The bearing force direction on the shafts confirms that gear meshing forces are directly transmitted to the bearings in the pressure angle direction.

isMisaligned(2)=1 Time=0.31416 s Surface: Second Piola-Kirchhoff stress, YY component (N/m²)

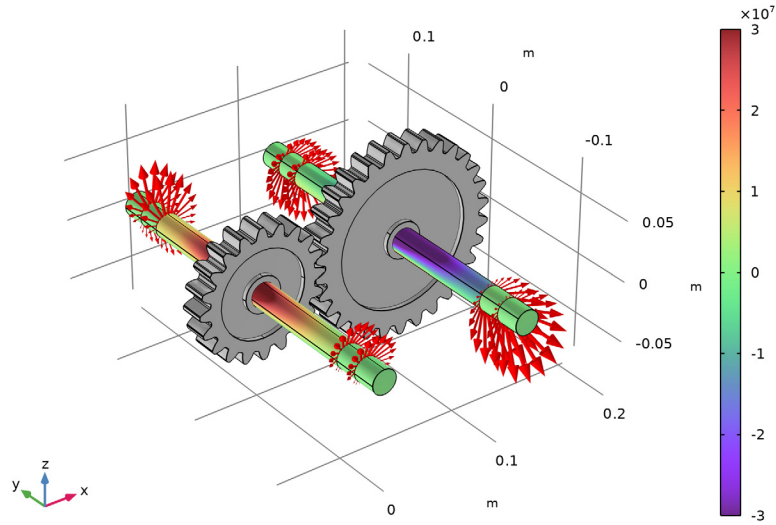

Figure 2: Stresses and bearing forces.

Figure 3 shows a comparison of angular speeds of the wheel and the pinion, for the cases of an aligned and a misaligned bearing. There is a slightly higher torsional vibration for the case of a misaligned bearing. The rattling vibrations in the misaligned case also persist for longer duration.

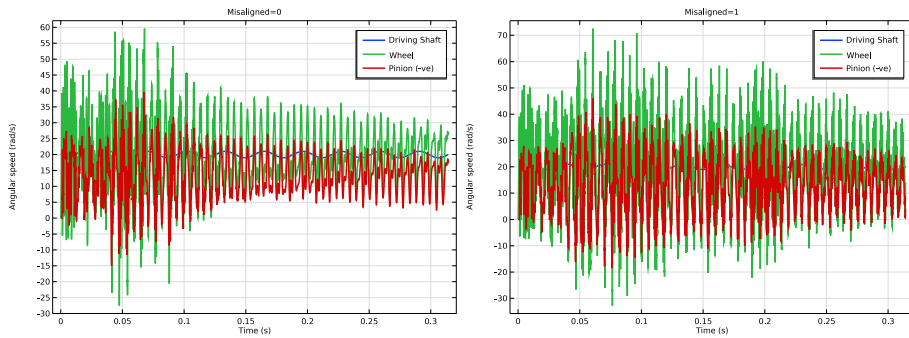

Figure 3: Angular velocity of the shafts for aligned bearings (left), and for a misaligned bearing (right).

The axial vibration at the wheel, after the rattling subsides, is shown in [Figure 4](#). In the case of a misaligned bearing, axial vibrations (accelerations) are mainly due to the misalignment in the bearing. As can be seen in [Figure 4](#) that the accelerations for the case of a misaligned bearing are significantly higher than that with aligned bearings.

Due to the angular misalignment in the bearings the force transmitted through the roller to the respective races has an axial component. This is the reason for the significant axial vibration of the shafts with misaligned bearing.

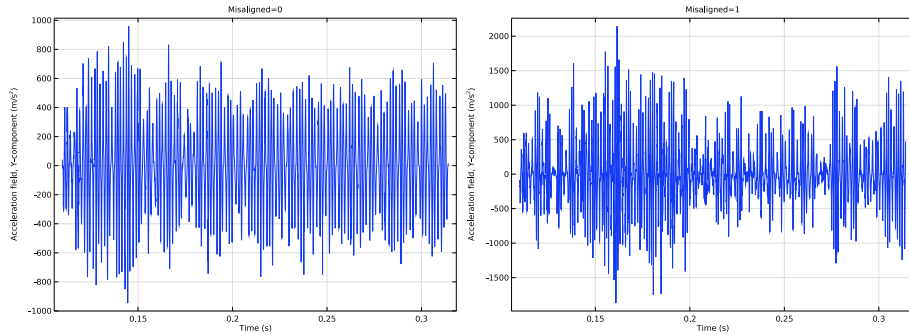

Figure 4: Axial acceleration at the wheel, for aligned bearings (left), and for a misaligned bearing (right).

Frequency spectra for axial vibrations are shown in [Figure 5](#). Compared to the case of aligned bearings, the case of a misaligned bearing shows participation from a broader range of frequencies. Vibration amplitude at higher frequencies are significantly higher in misaligned case.

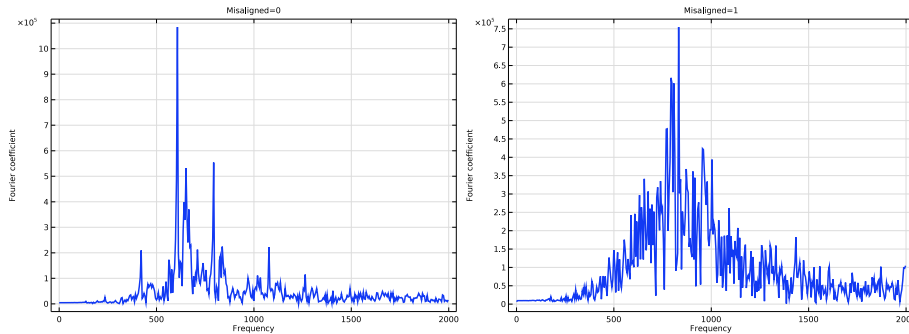

Figure 5: Frequency spectrum of the axial acceleration at the wheel, for the aligned (left) and misaligned (right) bearing.

Figure 6 shows the bearing force components for bearing 2. The case where the bearing is aligned is shown on the left, and the case where it is misaligned, on the right. In the misaligned case the force variations are slightly larger and contain higher frequencies.

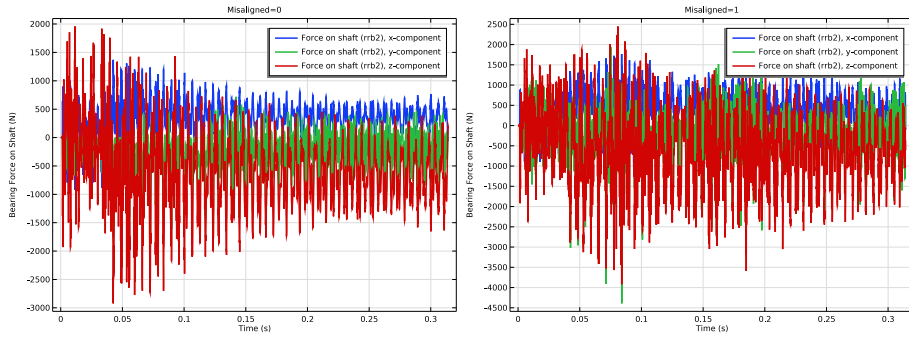

Figure 6: Force in bearing 2, for the aligned (left) and misaligned (right) bearing.

Figure 7 compares the moments in bearing 2. The result for the aligned bearings is presented on the left, and for the misaligned bearing on the right. One can clearly see a large moment about the x -axis in the misaligned case. The moment about z -axis also has slightly higher amplitude variation in misaligned case.

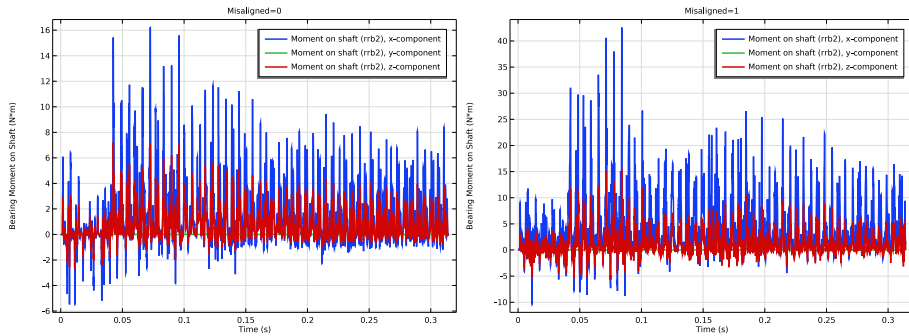

Figure 7: Moments in bearing 2, for the aligned (left) and misaligned (right) bearing.

A comparison of the rotor tilting in bearing 2 is shown in Figure 8 with results for the aligned case on the left and for the misaligned case on the right. Since the misalignment is

quite small, the mean tilting and amplitude do not differ significantly in both cases. However, in the misaligned case, there is a high frequency variation in the tilting.

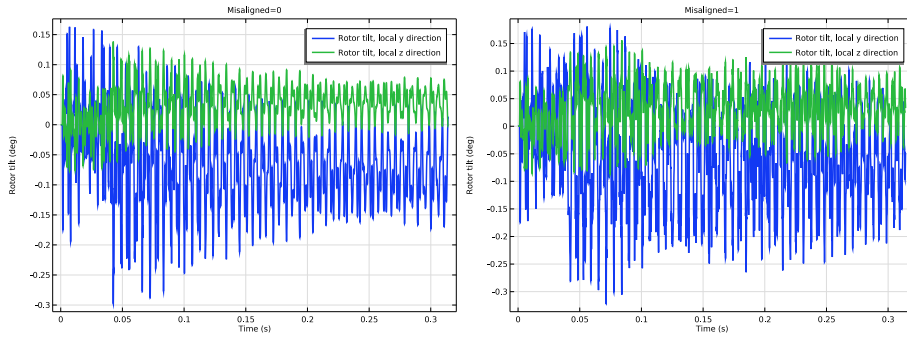

Figure 8: Rotor tilting in bearing 2, for the aligned (left) and misaligned (right) bearing.

The gear mesh contact force for the cases of aligned and misaligned bearings are shown in Figure 9. During the rattling vibration, intermittent contact in the gear meshing is clearly visible. The contact force variation is only lightly influenced by the misalignment in the bearing, however, after the shaft loading, rattling persists for longer in the case when bearing is misaligned.

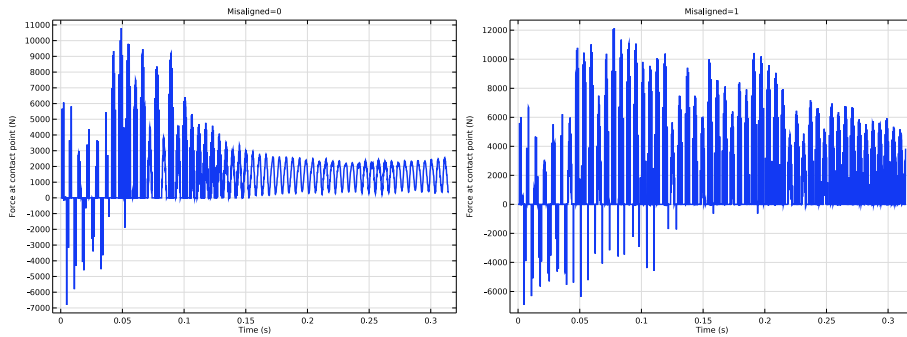



Figure 9: Gear mesh contact forces, for aligned bearings (left), and for a misaligned bearing (right).

Application Library path: Multibody_Dynamics_Module/Tutorials,
_Transmission/gear_rattle_with_bearing_misalignment



Modeling Instructions

From the **File** menu, choose **New**.

NEW

In the **New** window, click  **Model Wizard**.

MODEL WIZARD

- 1 In the **Model Wizard** window, click .
- 2 In the **Select Physics** tree, select **Structural Mechanics > Multibody Dynamics (mbd)**.
- 3 Click **Add**.
- 4 Click  **Study**.
- 5 In the **Select Study** tree, select **General Studies > Time Dependent**.
- 6 Click  **Done**.

Create a list of parameters for the speed and the loading torque.

GLOBAL DEFINITIONS

Parameters: General

- 1 In the **Model Builder** window, under **Global Definitions** click **Parameters I**.
- 2 In the **Settings** window for **Parameters**, type Parameters: General in the **Label** text field.
- 3 Locate the **Parameters** section. In the table, enter the following settings:

Name	Expression	Value	Description
omega0	20[rad/s]	20 rad/s	Mean angular speed
T0	100[N*m]	100 N·m	Loading torque
T	2*pi/omega0	0.31416 s	Time period
isMisaligned	0	0	Is misaligned

Create a list of parameters for the gears.

Parameters: Gears

- 1 In the **Home** toolbar, click  **Parameters** and choose **Add > Parameters**.
- 2 In the **Settings** window for **Parameters**, type Parameters: Gears in the **Label** text field.

3 Locate the **Parameters** section. In the table, enter the following settings:

Name	Expression	Value	Description
N1	20	20	No of teeth on gear 1
N2	30	30	No of teeth on gear 2
dp1	100[mm]	0.1 m	Pitch diameter of gear 1
dp2	150[mm]	0.15 m	Pitch diameter of gear 2
gr	N2/N1	1.5	Gear ratio
rc	0.5*(dp1+dp2)	0.125 m	Center to center distance
b1	1e-3[m]	0.001 m	Backlash

Create a list of parameters for the bearings.

Parameters: Roller Bearings

- 1 In the **Home** toolbar, click **Pi Parameters** and choose **Add > Parameters**.
- 2 In the **Settings** window for **Parameters**, type **Parameters: Roller Bearings** in the **Label** text field.
- 3 Locate the **Parameters** section. In the table, enter the following settings:

Name	Expression	Value	Description
db	1.33[mm]	0.00133 m	Ball diameter
dp	21.33[mm]	0.02133 m	Pitch diameter
rin	0.53*db	7.049E-4 m	Inner race radius
rout	0.53*db	7.049E-4 m	Outer race radius

Define a variable for the varying angular speed.

DEFINITIONS



Variables 1

- 1 In the **Model Builder** window, under **Component 1 (comp1)** right-click **Definitions** and choose **Variables**.
- 2 In the **Settings** window for **Variables**, locate the **Variables** section.
- 3 In the table, enter the following settings:

Name	Expression	Unit	Description
Omega	$\omega_0 * (1 + 0.05 * \sin(10 * \omega_0 * t))$	rad/s	Angular speed

Start by creating the gear system geometry using the geometry from the Part Libraries.

PART LIBRARIES

- 1 In the **Geometry** toolbar, click  **Part Libraries**.
- 2 In the **Model Builder** window, under **Component 1 (comp1)** click **Geometry 1**.
- 3 In the **Part Libraries** window, select **Multibody Dynamics Module > 3D > External Gears > spur_gear** in the tree.
- 4 Click  **Add to Geometry**.

GEOMETRY 1

Spur Gear 1 (pi1)

- 1 In the **Model Builder** window, under **Component 1 (comp1) > Geometry 1** click **Spur Gear 1 (pi1)**.
- 2 In the **Settings** window for **Part Instance**, locate the **Input Parameters** section.
- 3 In the table, enter the following settings:

Name	Expression	Value	Description
n	N1	20	Number of teeth
dp	dp1	0.1 m	Pitch diameter
lsr	3	3	Shaft length to pitch diameter ratio (Set 0 for no shaft)
egy	1	1	Gear axis, y-component
egz	0	0	Gear axis, z-component

- 4 Click  **Build Selected**.

Spur Gear 2 (pi2)

- 1 In the **Geometry** toolbar, click  **Part Instance** and choose **Spur Gear**.
- 2 In the **Settings** window for **Part Instance**, locate the **Input Parameters** section.
- 3 In the table, enter the following settings:



Name	Expression	Value	Description
n	N2	30	Number of teeth
dp	dp2	0.15 m	Pitch diameter
dhr	0.2/gr	0.13333	Hole diameter to pitch diameter ratio (Set 0 for no hole)
wgr	0.2/gr	0.13333	Gear width to pitch diameter ratio

Name	Expression	Value	Description
lsr	3/gr	2	Shaft length to pitch diameter ratio (Set 0 for no shaft)
xc	rc	0.125 m	Gear center, x-coordinate
egy	1	1	Gear axis, y-component
egz	0	0	Gear axis, z-component
th	360[deg]/2/N2	6 °	Mesh alignment angle

4 Click  **Build Selected**.

Create the work planes to partition the shafts at the bearing locations.

Work Plane 1 (wp1)

- 1 In the **Geometry** toolbar, click  **Work Plane**.
- 2 In the **Settings** window for **Work Plane**, locate the **Plane Definition** section.
- 3 From the **Plane** list, choose **zx-plane**.
- 4 In the **y-coordinate** text field, type -0.13.
- 5 Click  **Build Selected**.

Work Plane 2 (wp2)

- 1 Right-click **Work Plane 1 (wp1)** and choose **Duplicate**.
- 2 In the **Settings** window for **Work Plane**, locate the **Plane Definition** section.
- 3 In the **y-coordinate** text field, type 0.13.

Work Plane 3 (wp3)

- 1 Right-click **Work Plane 2 (wp2)** and choose **Duplicate**.
- 2 In the **Settings** window for **Work Plane**, locate the **Plane Definition** section.
- 3 In the **y-coordinate** text field, type -0.11.

Work Plane 4 (wp4)



- 1 Right-click **Work Plane 3 (wp3)** and choose **Duplicate**.
- 2 In the **Settings** window for **Work Plane**, locate the **Plane Definition** section.
- 3 In the **y-coordinate** text field, type 0.11.

Partition Objects 1 (par1)

- 1 In the **Geometry** toolbar, click  **Booleans and Partitions** and choose **Partition Objects**.
- 2 Click in the **Graphics** window and then press Ctrl+A to select both objects.
- 3 In the **Settings** window for **Partition Objects**, locate the **Partition Objects** section.

- 4 From the **Partition with** list, choose **Work plane**.
- 5 From the **Work plane** list, choose **Work Plane 1 (wp1)**.

Partition Objects 2 (par2)

- 1 Right-click **Partition Objects 1 (par1)** and choose **Duplicate**.
- 2 Select the object **pi1** only.
- 3 In the **Settings** window for **Partition Objects**, locate the **Partition Objects** section.
- 4 Click to select the  **Activate Selection** toggle button for **Objects to partition**.
- 5 Click in the **Graphics** window and then press Ctrl+A to select both objects.
- 6 From the **Work plane** list, choose **Work Plane 2 (wp2)**.
- 7 Click  **Build Selected**.

Partition Objects 3 (par3)

- 1 Right-click **Partition Objects 2 (par2)** and choose **Duplicate**.
- 2 Click in the **Graphics** window and then press Ctrl+A to select both objects.
- 3 In the **Settings** window for **Partition Objects**, locate the **Partition Objects** section.
- 4 From the **Work plane** list, choose **Work Plane 3 (wp3)**.
- 5 Click  **Build Selected**.

Partition Objects 4 (par4)

- 1 Right-click **Partition Objects 3 (par3)** and choose **Duplicate**.
- 2 In the **Settings** window for **Partition Objects**, locate the **Partition Objects** section.
- 3 From the **Work plane** list, choose **Work Plane 4 (wp4)**.
- 4 Click in the **Graphics** window and then press Ctrl+A to select both objects.
- 5 Click  **Build Selected**.

Disable the analysis of the geometry as the remaining small geometric details are needed.

- 6 In the **Model Builder** window, click **Geometry 1**.
- 7 In the **Settings** window for **Geometry**, locate the **Cleanup** section.
- 8 Clear the **Automatic detection of small details** checkbox.

ADD MATERIAL

- 1 In the **Materials** toolbar, click  **Add Material** to open the **Add Material** window.
- 2 Go to the **Add Material** window.
- 3 In the tree, select **Built-in > Structural steel**.

- 4 Click the **Add to Component** button in the window toolbar.
- 5 In the **Materials** toolbar, click  **Add Material** to close the **Add Material** window.

Create a **Hinge Joint** to specify the angular speed for the driver shaft.

MULTIBODY DYNAMICS (MBD)

Attachment I

- 1 In the **Physics** toolbar, click  **Boundaries** and choose **Attachment**.
- 2 Select Boundary 86 only.

Hinge Joint I

- 1 In the **Physics** toolbar, click  **Global** and choose **Hinge Joint**.
- 2 In the **Settings** window for **Hinge Joint**, locate the **Attachment Selection** section.
- 3 From the **Source** list, choose **Fixed**.
- 4 From the **Destination** list, choose **Attachment I**.
- 5 Locate the **Axis of Joint** section. Specify the \mathbf{e}_0 vector as

0	x
1	y
0	z

- 6 Locate the **Joint Elasticity** section. From the list, choose **Elastic joint**.

You create the elastic joint to allow the lateral and tilting motion of the shaft. You will constrain this motion later by adding the **Roller Bearing** support to the shafts.

Prescribed Motion I

- 1 In the **Physics** toolbar, click  **Attributes** and choose **Prescribed Motion**.
- 2 In the **Settings** window for **Prescribed Motion**, locate the **Prescribed Rotational Motion** section.
- 3 From the **Prescribed motion through** list, choose **Angular velocity**.
- 4 In the ω_p text field, type Omega.

Radial Roller Bearing I

- 1 In the **Physics** toolbar, click  **Boundaries** and choose **Radial Roller Bearing**.
- 2 Select Boundaries 87, 88, 118, and 119 only.
- 3 In the **Settings** window for **Radial Roller Bearing**, locate the **Bearing Orientation** section.
- 4 From the **Bearing axis** list, choose **y-axis**.

- 5 From the **Local y direction** list, choose **User defined**.
- 6 Specify the **Orientation vector defining local y direction** vector as

1	x
0	y
0	z

- 7 Locate the **Geometric Properties** section. In the d_b text field, type db.
- 8 In the d_p text field, type dp.
- 9 In the r_{in} text field, type rin.
- 10 In the r_{out} text field, type rout.

Radial Roller Bearing 2

- 1 Right-click **Radial Roller Bearing 1** and choose **Duplicate**.
- 2 In the **Settings** window for **Radial Roller Bearing**, locate the **Boundary Selection** section.
- 3 Click  **Clear Selection**.
- 4 Select Boundaries 97, 98, 134, and 135 only.

Radial Roller Bearing 3

- 1 Right-click **Radial Roller Bearing 2** and choose **Duplicate**.
- 2 In the **Settings** window for **Radial Roller Bearing**, locate the **Boundary Selection** section.
- 3 Click  **Clear Selection**.
- 4 Select Boundaries 343, 344, 378, and 385 only.

Radial Roller Bearing 4

- 1 Right-click **Radial Roller Bearing 3** and choose **Duplicate**.
- 2 In the **Settings** window for **Radial Roller Bearing**, locate the **Boundary Selection** section.
- 3 Click  **Clear Selection**.
- 4 Select Boundaries 353, 354, 382, and 389 only.

Add angular misalignment in the bearing located opposite to the prescribed end of the driver shaft. Use a parameter `isMisaligned` to enable/disable the misalignment in the bearing.

Radial Roller Bearing 2

In the **Model Builder** window, click **Radial Roller Bearing 2**.

Misalignment 1

- 1 In the **Physics** toolbar, click  **Attributes** and choose **Misalignment**.
- 2 In the **Settings** window for **Misalignment**, locate the **Angular Misalignment** section.
- 3 In the θ_{0y} text field, type 0.1[deg]*isMisaligned.

Spur Gear 1

- 1 In the **Physics** toolbar, click  **Domains** and choose **Spur Gear**.
- 2 Select Domain 1 only.
- 3 In the **Settings** window for **Spur Gear**, locate the **Gear Properties** section.
- 4 In the n text field, type N1.
- 5 In the d_p text field, type dp1.
- 6 In the α text field, type 25[deg].
- 7 Locate the **Gear Axis** section. Specify the \mathbf{e}_g vector as

0	x
1	y
0	z

- 8 Locate the **Center of Rotation** section. From the list, choose **User defined**.

Spur Gear 2

- 1 Right-click **Spur Gear 1** and choose **Duplicate**.
- 2 In the **Settings** window for **Spur Gear**, locate the **Domain Selection** section.
- 3 Click  **Clear Selection**.
- 4 Select Domain 7 only.
- 5 Locate the **Gear Properties** section. In the n text field, type N2.
- 6 In the d_p text field, type dp2.
- 7 Locate the **Center of Rotation** section. Specify the \mathbf{X}_c vector as

rc	x
0	y
0	z

Gear Pair 1

- 1 In the **Physics** toolbar, click  **Global** and choose **Gear Pair**.
- 2 In the **Settings** window for **Gear Pair**, locate the **Gear Selection** section.

- 3 From the **Wheel** list, choose **Spur Gear 1**.
- 4 From the **Pinion** list, choose **Spur Gear 2**.
- 5 Locate the **Gear Pair Properties** section. Select the **Include backlash** checkbox.
- 6 Locate the **Contact Force Computation** section. From the list, choose **Computed using penalty method**.
- 7 In the p_c text field, type $1e8$.

Backlash 1

- 1 In the **Model Builder** window, click **Backlash 1**.
- 2 In the **Settings** window for **Backlash**, locate the **Backlash** section.
- 3 In the b_1 text field, type $b1$.
Increase the penalty factor 200 times to reduce the error in the backlash.
- 4 In the p_b text field, type $((1[1/ms])^2)*mbd.grp1.Ie*200$.

Rigid Connector 1

- 1 In the **Physics** toolbar, click  **Boundaries** and choose **Rigid Connector**.
- 2 Select Boundary 359 only.

Add a loading torque on the driven shaft. Activate the torque only after the driver shaft has completed a 45 degree rotation.

Applied Moment 1

- 1 In the **Physics** toolbar, click  **Attributes** and choose **Applied Moment**.
- 2 In the **Settings** window for **Applied Moment**, locate the **Applied Moment** section.
- 3 Specify the **M** vector as

0	x
$T0*(t>T/8)$	y
0	z

Use a swept mesh for the shafts.

MESH 1

Free Triangular 1

- 1 In the **Mesh** toolbar, click  **More Generators** and choose **Free Triangular**.
- 2 Select Boundaries 86 and 342 only.

Size 1

- 1 Right-click **Free Triangular 1** and choose **Size**.
- 2 In the **Settings** window for **Size**, locate the **Element Size** section.
- 3 From the **Predefined** list, choose **Extra fine**.

Swept 1

- 1 In the **Mesh** toolbar, click  **Swept**.
- 2 In the **Settings** window for **Swept**, locate the **Domain Selection** section.
- 3 From the **Geometric entity level** list, choose **Domain**.
- 4 Select Domains 2–6 and 8–12 only.

Free Tetrahedral 1

- 1 In the **Mesh** toolbar, click  **Free Tetrahedral**.
- 2 In the **Settings** window for **Free Tetrahedral**, click  **Build All**.

STUDY 1

Step 1: Time Dependent

Use a small time step in the beginning to resolve the rattling vibration.

- 1 In the **Model Builder** window, under **Study 1** click **Step 1: Time Dependent**.
- 2 In the **Settings** window for **Time Dependent**, locate the **Study Settings** section.
- 3 In the **Output times** text field, type range (0, T/20000, T/4) range (T/4+T/10000, T/10000, T).
- 4 Click the  **Show More Options** button in the **Model Builder** toolbar.
- 5 In the **Show More Options** dialog, select **Study > Batch and Cluster** in the tree.
- 6 In the tree, select the checkbox for the node **Study > Batch and Cluster**.
- 7 Click **OK**.

Add a batch sweep to solve for two cases: first, all bearings aligned, and second, one of the bearings misaligned.

Batch Sweep

- 1 In the **Study** toolbar, click  **Batch** and choose **Batch Sweep**.
- 2 In the **Settings** window for **Batch Sweep**, locate the **Output While Solving** section.
- 3 Clear the **Accumulated probe table** checkbox.
- 4 Locate the **Batch Settings** section. Find the **Before sweep** subsection. Clear the **Clear meshes** checkbox.

- 5 Clear the **Clear solutions** checkbox.
- 6 Select the **Synchronize solutions** checkbox.
- 7 Locate the **Advanced Settings** section. In the **Number of simultaneous jobs** text field, type 2.
- 8 Locate the **Study Settings** section. Click  **Add**.
- 9 In the table, enter the following settings:

Parameter name	Parameter value list	Parameter unit
isMisaligned (Is misaligned)	0 1	

Change the settings for the time stepping and maximum number of iterations in the solver to reduce the computation time.

Solution 1 (sol1)

- 1 In the **Study** toolbar, click  **Show Default Solver**.
- 2 In the **Model Builder** window, expand the **Solution 1 (sol1)** node, then click **Time-Dependent Solver 1**.
- 3 In the **Settings** window for **Time-Dependent Solver**, click to expand the **Time Stepping** section.
- 4 From the **Steps taken by solver** list, choose **Intermediate**.
- 5 In the **Model Builder** window, expand the **Study 1 > Solver Configurations > Solution 1 (sol1) > Time-Dependent Solver 1** node, then click **Fully Coupled 1**.
- 6 In the **Settings** window for **Fully Coupled**, click to expand the **Method and Termination** section.
- 7 From the **Jacobian update** list, choose **Once per time step**.
- 8 In the **Maximum number of iterations** text field, type 10.

Batch Data

In the **Study** toolbar, click  **Compute**.

RESULTS

Displacement (mbd)

Displacement is the default plot. Duplicate it and follow the instructions below to create the stress plot as shown in [Figure 2](#).

Stress (mbd)

- 1 In the **Model Builder** window, expand the **Results** node.

- 2 Right-click **Displacement (mbd)** and choose **Duplicate**.
- 3 In the **Settings** window for **3D Plot Group**, type **Stress (mbd)** in the **Label** text field.

Surface

- 1 In the **Model Builder** window, expand the **Stress (mbd)** node, then click **Surface**.
- 2 In the **Settings** window for **Surface**, locate the **Expression** section.
- 3 In the **Expression** text field, type **mbd.SYY**.
- 4 Click to expand the **Range** section. Select the **Manual color range** checkbox.
- 5 In the **Minimum** text field, type **-3e7**.
- 6 In the **Maximum** text field, type **3e7**.

Gears use the **Rigid Material** model. Therefore, it is not possible to plot the stress in the gears. Duplicate the existing dataset and restrict the new dataset selection to gears only. You will use this dataset to display the gears in a stress plot.

Study 1/Parametric Solutions 1 (3) (sol2)

- 1 In the **Model Builder** window, expand the **Results > Datasets** node.
- 2 Right-click **Results > Datasets > Study 1/Parametric Solutions 1 (sol2)** and choose **Duplicate**.

Selection

- 1 In the **Results** toolbar, click  **Attributes** and choose **Selection**.
- 2 In the **Settings** window for **Selection**, locate the **Geometric Entity Selection** section.
- 3 From the **Geometric entity level** list, choose **Domain**.
- 4 Select Domains 1 and 7 only.

Surface 2

- 1 In the **Model Builder** window, right-click **Surface** and choose **Duplicate**.
- 2 In the **Settings** window for **Surface**, locate the **Expression** section.
- 3 In the **Expression** text field, type **1**.
- 4 Locate the **Coloring and Style** section. From the **Coloring** list, choose **Uniform**.
- 5 From the **Color** list, choose **Gray**.
- 6 Locate the **Data** section. From the **Dataset** list, choose **Study 1/Parametric Solutions 1 (3) (sol2)**.
- 7 From the **Solution parameters** list, choose **From parent**.

Add arrow plots to plot the force distribution in the roller bearings.

Arrow Surface 1

- 1 In the **Model Builder** window, right-click **Stress (mbd)** and choose **Arrow Surface**.
- 2 In the **Settings** window for **Arrow Surface**, click **Replace Expression** in the upper-right corner of the **Expression** section. From the menu, choose **Component 1 (comp1) > Multibody Dynamics > Radial Roller Bearing 1 > mbd.rrb1.fbx,...,mbd.rrb1.fbz - Bearing force distribution (spatial frame)**.
- 3 Locate the **Arrow Positioning** section. From the **Placement** list, choose **Mesh vertices**.
- 4 Locate the **Coloring and Style** section.
- 5 Select the **Scale factor** checkbox. In the associated text field, type 2E-4.

Deformation 1

- 1 Right-click **Arrow Surface 1** and choose **Deformation**.
- 2 In the **Settings** window for **Deformation**, locate the **Expression** section.
- 3 In the **X-component** text field, type `mbd.rrb1.u_cage`.
- 4 In the **Y-component** text field, type `mbd.rrb1.v_cage`.
- 5 In the **Z-component** text field, type `mbd.rrb1.w_cage`.
- 6 Locate the **Scale** section.
- 7 Select the **Scale factor** checkbox. In the associated text field, type 1.

Arrow Surface 2

- 1 In the **Model Builder** window, under **Results > Stress (mbd)** right-click **Arrow Surface 1** and choose **Duplicate**.
- 2 In the **Settings** window for **Arrow Surface**, click to expand the **Inherit Style** section.
- 3 From the **Plot** list, choose **Arrow Surface 1**.
Due to misalignment, the reaction forces are significantly larger in this bearing. Do not inherit the arrow scale for this bearing.
- 4 Click to expand the **Title** section. From the **Title type** list, choose **None**.
- 5 Locate the **Expression** section. In the **X-component** text field, type `mbd.rrb2.fbx`.
- 6 In the **Y-component** text field, type `mbd.rrb2.fby`.
- 7 In the **Z-component** text field, type `mbd.rrb2.fbz`.

Deformation 1

- 1 In the **Model Builder** window, expand the **Arrow Surface 2** node, then click **Deformation 1**.
- 2 In the **Settings** window for **Deformation**, locate the **Expression** section.
- 3 In the **X-component** text field, type `mbd.rrb2.u_cage`.

- 4 In the **Y-component** text field, type `mbd.rrb2.v_cage`.
- 5 In the **Z-component** text field, type `mbd.rrb2.w_cage`.

Arrow Surface 3

- 1 In the **Model Builder** window, under **Results > Stress (mbd)** right-click **Arrow Surface 2** and choose **Duplicate**.
- 2 In the **Settings** window for **Arrow Surface**, locate the **Expression** section.
- 3 In the **X-component** text field, type `mbd.rrb3.fbx`.
- 4 In the **Y-component** text field, type `mbd.rrb3.fby`.
- 5 In the **Z-component** text field, type `mbd.rrb3.fbz`.

Deformation 1

- 1 In the **Model Builder** window, expand the **Arrow Surface 3** node, then click **Deformation 1**.
- 2 In the **Settings** window for **Deformation**, locate the **Expression** section.
- 3 In the **X-component** text field, type `mbd.rrb3.u_cage`.
- 4 In the **Y-component** text field, type `mbd.rrb3.v_cage`.
- 5 In the **Z-component** text field, type `mbd.rrb3.w_cage`.

Arrow Surface 4



- 1 In the **Model Builder** window, under **Results > Stress (mbd)** right-click **Arrow Surface 3** and choose **Duplicate**.
- 2 In the **Settings** window for **Arrow Surface**, locate the **Expression** section.
- 3 In the **X-component** text field, type `mbd.rrb4.fbx`.
- 4 In the **Y-component** text field, type `mbd.rrb4.fby`.
- 5 In the **Z-component** text field, type `mbd.rrb4.fbz`.

Deformation 1

- 1 In the **Model Builder** window, expand the **Arrow Surface 4** node, then click **Deformation 1**.
- 2 In the **Settings** window for **Deformation**, locate the **Expression** section.
- 3 In the **X-component** text field, type `mbd.rrb4.u_cage`.
- 4 In the **Y-component** text field, type `mbd.rrb4.v_cage`.
- 5 In the **Z-component** text field, type `mbd.rrb4.w_cage`.

Stress (mbd)

- 1 In the **Model Builder** window, under **Results** click **Stress (mbd)**.
- 2 In the **Settings** window for **3D Plot Group**, click to expand the **Title** section.

- 3 From the **Title type** list, choose **Manual**.
- 4 In the **Title** text area, type Surface: Second Piola-Kirchhoff stress, YY component (N/m²).
- 5 Click the  **Zoom Extents** button in the **Graphics** toolbar.
- 6 In the **Stress (mbd)** toolbar, click  **Plot**.

Follow the instructions below to plot the angular speed of the driving shaft, wheel and pinion, as shown in [Figure 3](#).

Angular Speed

- 1 In the **Results** toolbar, click  **ID Plot Group**.
- 2 In the **Settings** window for **ID Plot Group**, locate the **Data** section.
- 3 From the **Dataset** list, choose **Study I/Parametric Solutions I (2) (sol2)**.
- 4 In the **Label** text field, type Angular Speed.
- 5 Locate the **Data** section. From the **Parameter selection (isMisaligned)** list, choose **First**.

Global I

- 1 Right-click **Angular Speed** and choose **Global**.
- 2 In the **Settings** window for **Global**, click **Replace Expression** in the upper-right corner of the **y-Axis Data** section. From the menu, choose **Component I (comp1) > Definitions > Variables > Omega - Angular speed - rad/s**.
- 3 Locate the **y-Axis Data** section. In the table, enter the following settings:

Expression	Unit	Description
Omega	rad/s	Driving Shaft

- 4 Click **Add Expression** in the upper-right corner of the **y-Axis Data** section. From the menu, choose **Component I (comp1) > Multibody Dynamics > Gear pairs > Gear Pair I > Wheel > mbd.grp1.tht_wh - Wheel angular velocity - rad/s**.
- 5 Locate the **y-Axis Data** section. In the table, enter the following settings:

Expression	Unit	Description
mbd.grp1.tht_wh	rad/s	Wheel

- 6 Click **Add Expression** in the upper-right corner of the **y-Axis Data** section. From the menu, choose **Component I (comp1) > Multibody Dynamics > Gear pairs > Gear Pair I > Pinion > mbd.grp1.tht_pn - Pinion angular velocity - rad/s**.

7 Locate the **y-Axis Data** section. In the table, enter the following settings:

Expression	Unit	Description
-mbd.grp1.tht_pn	rad/s	Pinion (-ve)

8 Click to expand the **Coloring and Style** section. From the **Width** list, choose **2**.

9 Click to expand the **Legends** section. From the **Legends** list, choose **Manual**.

10 In the table, enter the following settings:

Legends
Driving Shaft
Wheel
Pinion (-ve)

Angular Speed

1 In the **Model Builder** window, click **Angular Speed**.

2 In the **Settings** window for **ID Plot Group**, locate the **Plot Settings** section.

3 Select the **y-axis label** checkbox. In the associated text field, type Angular speed (rad/s).

4 Click to expand the **Title** section. From the **Title type** list, choose **Manual**.

5 In the **Title** text area, type Misaligned=eval(isMisaligned).

6 In the **Angular Speed** toolbar, click  **Plot**.

Change the `isMisaligned` parameter to plot the angular velocity for the misaligned case.

7 Locate the **Data** section. From the **Parameter selection (isMisaligned)** list, choose **Last**.

8 In the **Angular Speed** toolbar, click  **Plot**.

You can compare the reaction forces and moments of the bearing for aligned and misaligned cases. These plots are shown in [Figure 6](#) and [Figure 7](#) and can be reproduced using the instructions below.

Bearing Force

1 In the **Results** toolbar, click  **ID Plot Group**.

2 In the **Settings** window for **ID Plot Group**, locate the **Data** section.

3 From the **Dataset** list, choose **Study 1/Parametric Solutions 1 (2) (sol2)**.

4 In the **Label** text field, type Bearing Force.

5 Locate the **Data** section. From the **Parameter selection (isMisaligned)** list, choose **First**.



Global I

- 1 Right-click **Bearing Force** and choose **Global**.
- 2 In the **Settings** window for **Global**, click **Replace Expression** in the upper-right corner of the **y-Axis Data** section. From the menu, choose **Component 1 (comp1) > Multibody Dynamics > Radial Roller Bearing 2 > Force on shaft (rrb2) (spatial frame) - N > All expressions in this group**.
- 3 Locate the **Coloring and Style** section. From the **Width** list, choose **2**.
- 4 Locate the **Legends** section. From the **Legends** list, choose **Manual**.
- 5 In the table, enter the following settings:

Legends
Force on shaft (rrb2), x-component
Force on shaft (rrb2), y-component
Force on shaft (rrb2), z-component

- 6 In the **Bearing Force** toolbar, click  **Plot**.

Bearing Force

- 1 In the **Model Builder** window, click **Bearing Force**.
- 2 In the **Settings** window for **ID Plot Group**, locate the **Plot Settings** section.
- 3 Select the **y-axis label** checkbox. In the associated text field, type Bearing Force on Shaft (N).
- 4 Locate the **Title** section. From the **Title type** list, choose **Manual**.
- 5 In the **Title** text area, type Misaligned=eval(isMisaligned).
- 6 In the **Bearing Force** toolbar, click  **Plot**.
- 7 Locate the **Data** section. From the **Parameter selection (isMisaligned)** list, choose **Last**.
- 8 In the **Bearing Force** toolbar, click  **Plot**.

Bearing Moment

- 1 In the **Results** toolbar, click  **ID Plot Group**.
- 2 In the **Settings** window for **ID Plot Group**, locate the **Data** section.
- 3 From the **Dataset** list, choose **Study 1/Parametric Solutions 1 (2) (sol2)**.
- 4 In the **Label** text field, type Bearing Moment.
- 5 Locate the **Data** section. From the **Parameter selection (isMisaligned)** list, choose **First**.



Global I

- 1 Right-click **Bearing Moment** and choose **Global**.

- 2 In the **Settings** window for **Global**, click **Replace Expression** in the upper-right corner of the **y-Axis Data** section. From the menu, choose **Component 1 (comp1) > Multibody Dynamics > Radial Roller Bearing 2 > Moment on shaft (rrb2) (spatial frame) - N·m > All expressions in this group**.
- 3 Locate the **Coloring and Style** section. From the **Width** list, choose **2**.
- 4 Locate the **Legends** section. From the **Legends** list, choose **Manual**.
- 5 In the table, enter the following settings:



Legends
Moment on shaft (rrb2), x-component
Moment on shaft (rrb2), y-component
Moment on shaft (rrb2), z-component

Bearing Moment

- 1 In the **Model Builder** window, click **Bearing Moment**.
- 2 In the **Settings** window for **ID Plot Group**, locate the **Plot Settings** section.
- 3 Select the **y-axis label** checkbox. In the associated text field, type **Bearing Moment on Shaft (N*m)**.
- 4 Locate the **Title** section. From the **Title type** list, choose **Manual**.
- 5 In the **Title** text area, type **Misaligned=eval(isMisaligned)**.
- 6 In the **Bearing Moment** toolbar, click  **Plot**.
- 7 Locate the **Data** section. From the **Parameter selection (isMisaligned)** list, choose **Last**.
- 8 In the **Bearing Moment** toolbar, click  **Plot**.

Angular misalignment in the bearings causes large axial vibrations. Start by creating a **Cut Point** at the center of the wheel to plot the axial vibration at this location.

Cut Point 3D 1

- 1 In the **Results** toolbar, click  **Cut Point 3D**.
- 2 In the **Settings** window for **Cut Point 3D**, locate the **Data** section.
- 3 From the **Dataset** list, choose **Study 1/Parametric Solutions 1 (2) (sol2)**.
- 4 Locate the **Point Data** section. In the **X** text field, type **0**.
- 5 In the **Y** text field, type **0**.
- 6 In the **Z** text field, type **0**.
- 7 Click  **Plot**.

Follow the instructions below to plot the axial vibration at the center of the wheel for aligned and misaligned cases. This plot is shown in [Figure 4](#).



Y Acceleration of Wheel

- 1 In the **Results** toolbar, click  **ID Plot Group**.
- 2 In the **Settings** window for **ID Plot Group**, type Y Acceleration of Wheel in the **Label** text field.
- 3 Locate the **Data** section. From the **Dataset** list, choose **Cut Point 3D I**.
Initially, due to rattling of the gears, acceleration response will have transient effects. Plot the acceleration after a time when transient effects are subsided.
- 4 From the **Time selection** list, choose **Manual**.
- 5 In the **Time indices (I-12501)** text field, type range (6000, 1, 12501).
- 6 From the **Parameter selection (isMisaligned)** list, choose **First**.

Point Graph I

- 1 Right-click **Y Acceleration of Wheel** and choose **Point Graph**.
- 2 In the **Settings** window for **Point Graph**, locate the **y-Axis Data** section.
- 3 In the **Expression** text field, type vtt.

Y Acceleration of Wheel

- 1 In the **Model Builder** window, click **Y Acceleration of Wheel**.
- 2 In the **Settings** window for **ID Plot Group**, locate the **Title** section.
- 3 From the **Title type** list, choose **Manual**.
- 4 In the **Title** text area, type Misaligned=eval(isMisaligned).
- 5 In the **Y Acceleration of Wheel** toolbar, click  **Plot**.
- 6 Locate the **Data** section. From the **Parameter selection (isMisaligned)** list, choose **Last**.
- 7 In the **Y Acceleration of Wheel** toolbar, click  **Plot**.

Duplicate the axial vibration plot and follow the instructions below to plot the frequency spectrum of the axial vibrations for aligned and misaligned cases, as shown in [Figure 5](#).

Y Acceleration of Wheel (Frequency Spectrum)

- 1 Right-click **Y Acceleration of Wheel** and choose **Duplicate**.
- 2 In the **Settings** window for **ID Plot Group**, type Y Acceleration of Wheel (Frequency Spectrum) in the **Label** text field.

The gear rattle due to unloaded shaft causes initial transient vibration in the system. Remove this transient vibration data for the frequency spectrum plot.

- 3 Locate the **Data** section. From the **Parameter selection (isMisaligned)** list, choose **First**.

Point Graph 1

- 1 In the **Model Builder** window, expand the **Y Acceleration of Wheel (Frequency Spectrum)** node, then click **Point Graph 1**.
- 2 In the **Settings** window for **Point Graph**, locate the **x-Axis Data** section.
- 3 From the **Parameter list**, choose **Discrete Fourier transform**.
- 4 From the **Show list**, choose **Frequency spectrum**.
- 5 Select the **Frequency range** checkbox.
- 6 In the **Maximum** text field, type 2000.
- 7 Click to expand the **Coloring and Style** section. From the **Width list**, choose **2**.
- 8 In the **Y Acceleration of Wheel (Frequency Spectrum)** toolbar, click  **Plot**.

Y Acceleration of Wheel (Frequency Spectrum)

- 1 In the **Model Builder** window, click **Y Acceleration of Wheel (Frequency Spectrum)**.
- 2 In the **Settings** window for **ID Plot Group**, locate the **Data** section.
- 3 From the **Parameter selection (isMisaligned)** list, choose **Last**.
- 4 In the **Y Acceleration of Wheel (Frequency Spectrum)** toolbar, click  **Plot**.

The rotor tilting in the bearing is compared in [Figure 8](#) for aligned and misaligned cases. Follow the instructions below to reproduce this plot.

Rotor tilt at Bearing 2

- 1 In the **Results** toolbar, click  **ID Plot Group**.
- 2 In the **Settings** window for **ID Plot Group**, locate the **Data** section.
- 3 From the **Dataset list**, choose **Study 1/Parametric Solutions 1 (2) (sol2)**.
- 4 In the **Label** text field, type Rotor tilt at Bearing 2.
- 5 Locate the **Data** section. From the **Parameter selection (isMisaligned)** list, choose **First**.

Global 1



- 1 Right-click **Rotor tilt at Bearing 2** and choose **Global**.
- 2 In the **Settings** window for **Global**, locate the **y-Axis Data** section.
- 3 In the table, enter the following settings:

Expression	Unit	Description
mbd.rrb2.alphay	deg	Tilt of rotor about local y direction
mbd.rrb2.alphaz	deg	Tilt of rotor about local z direction

- 4 Locate the **Coloring and Style** section. From the **Width** list, choose **2**.
- 5 Locate the **Legends** section. From the **Legends** list, choose **Manual**.
- 6 In the table, enter the following settings:

Legends
Rotor tilt, local y direction
Rotor tilt, local z direction

Rotor tilt at Bearing 2

- 1 In the **Model Builder** window, click **Rotor tilt at Bearing 2**.
- 2 In the **Settings** window for **ID Plot Group**, locate the **Plot Settings** section.
- 3 Select the **y-axis label** checkbox. In the associated text field, type `Rotor tilt (deg)`.
- 4 Locate the **Title** section. From the **Title type** list, choose **Manual**.
- 5 In the **Title** text area, type `Misaligned=eval(isMisaligned)`.
- 6 In the **Rotor tilt at Bearing 2** toolbar, click  **Plot**.
- 7 Locate the **Data** section. From the **Parameter selection (isMisaligned)** list, choose **Last**.
- 8 In the **Rotor tilt at Bearing 2** toolbar, click  **Plot**.

Gear mesh contact force is an indicator of the rattling vibrations in shafts. This plot is shown in [Figure 9](#), and it can be reproduced by using the instructions below.

Gear Mesh Contact Force



- 1 In the **Results** toolbar, click  **ID Plot Group**.
- 2 In the **Settings** window for **ID Plot Group**, locate the **Data** section.
- 3 From the **Dataset** list, choose **Study 1/Parametric Solutions 1 (2) (sol2)**.
- 4 In the **Label** text field, type `Gear Mesh Contact Force`.
- 5 Locate the **Data** section. From the **Parameter selection (isMisaligned)** list, choose **First**.

Global 1

- 1 Right-click **Gear Mesh Contact Force** and choose **Global**.
- 2 In the **Settings** window for **Global**, click **Replace Expression** in the upper-right corner of the **y-Axis Data** section. From the menu, choose **Component 1 (comp1) > Multibody Dynamics > Gear pairs > Gear Pair 1 > mbd.grp1.Fc - Force at contact point - N**.
- 3 Locate the **Coloring and Style** section. From the **Width** list, choose **2**.

Gear Mesh Contact Force

- 1 In the **Model Builder** window, click **Gear Mesh Contact Force**.

- 2 In the **Settings** window for **ID Plot Group**, locate the **Title** section.
- 3 From the **Title type** list, choose **Manual**.
- 4 In the **Title** text area, type `Misaligned=eval(isMisaligned)`.
- 5 Locate the **Legend** section. Clear the **Show legends** checkbox.
- 6 In the **Gear Mesh Contact Force** toolbar, click  **Plot**.
- 7 Locate the **Data** section. From the **Parameter selection (isMisaligned)** list, choose **Last**.
- 8 In the **Gear Mesh Contact Force** toolbar, click  **Plot**.

Finally, use the instructions below to generate the animation of the stress variation in the shafts.

Animation 1

- 1 In the **Results** toolbar, click  **Animation** and choose **Player**.
- 2 In the **Settings** window for **Animation**, locate the **Scene** section.
- 3 From the **Subject** list, choose **Stress (mbd)**.
- 4 Locate the **Frames** section. In the **Number of frames** text field, type 50.
- 5 Locate the **Animation Editing** section. From the **Parameter value (isMisaligned)** list, choose **I**.