



Model created in COMSOL Multiphysics 6.4

# Differential Gear Mechanism

## *Introduction*

---

This model simulates the mechanism of a differential gear used in cars and other wheeled vehicles. The model is built using the gears functionality in the Multibody Dynamics Module in the COMSOL Multiphysics.

A differential allows the outer drive wheel to rotate faster than the inner drive wheel during a turn. This is necessary when a vehicle turns in order to allow the wheel that is traveling along the outside of the turning curve to roll faster and to cover greater distance than the wheel on the inside of the turning curve. The average of the rotational speed of the two driving wheels is simply the input rotational speed of the drive shaft. An increase in the speed of one wheel is balanced by a decrease in the speed of the other.

## *Model Definition*

---

The geometry of a differential is shown in [Figure 1](#).

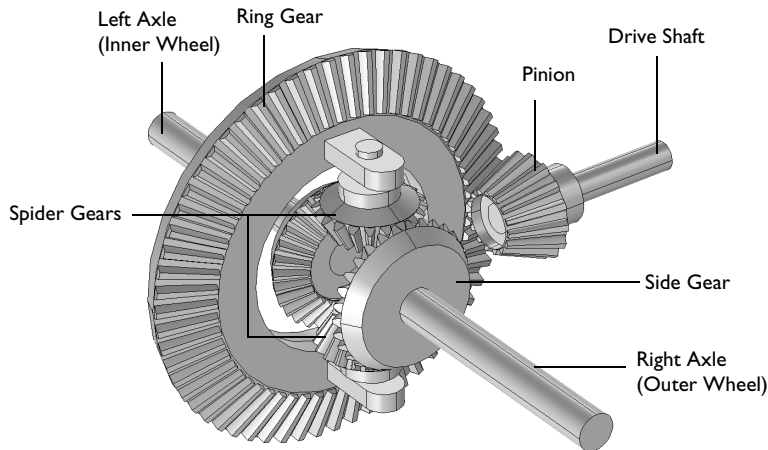

*Figure 1: Geometry of a differential mechanism.*

### **GEOMETRY AND CONNECTIONS**

A differential has the following components:

- A drive shaft with pinion
- A ring gear

- Two spider gears
- Left and right axles with side gears

A drive shaft is connected to the ring gear through a pinion. Two spider gears are mounted on the ring gear in such a way that they are free to rotate about their own axis. These spider gears are connected to side gears that are mounted on the inner end of the two axles.

The wheels, which are not modeled, are supposed to be mounted on the outer ends of the two axles. In this model, it is assumed that the wheel mounted on the right axle is on the outer side while vehicle takes a turn.

### **WORKING OF A DIFFERENTIAL**

A differential performs the following tasks:

- Allows the left and the right axle to rotate at different speeds.
- Transfers power at  $90^\circ$ .
- Reduces speed of wheels compared to the drive shaft.

Under normal conditions, with small tire slip, the ratio of the speeds of the two driving wheels is determined by the track-width of the vehicle (the distance between the driving wheels) and the radius of the turn.

#### *Straight Path*

When a vehicle moves on a straight path, both wheels of the vehicle roll with the same speed. In this situation, both axles rotate with the same speed while the spider gears follow a planetary motion and thus do not spin about their own axes.

#### *Curved Path*

In case of a curved path, the outer wheel has to cover a longer distance. It must therefore roll faster than the inner wheel in order to avoid any slip. If the differential was absent in the vehicle, both wheels would have to rotate with the same speed causing slip between the wheels and the ground.

A differential allows the two wheels of the vehicle to rotate with different speeds. In this situation the spider gears start spinning together with their planetary motion. Spinning of the spider gears creates a difference in the speed of both wheels.

### **MODEL PARAMETERS**

- The gear ratio between the pinion and the ring gear is 4.
- The gear ratio between the spider gear and the side gear is 1.5.

- To avoid any slip on a curved path, speed of the outer wheel is supposed to be 6 times higher than that of the inner wheel.
- The vehicle enters a curved path after one revolution of the drive shaft and returns back to a straight path after three revolutions of the drive shaft.

#### CONSTRAINTS AND LOADS

- The drive shaft is rotating about the  $x$ -axis with an angular velocity of 200 rad/s.
- The ring gear is hinged about the  $y$ -axis.
- The side gears (or axles) are hinged about the  $y$ -axis.

An external torque is applied on both axles while vehicle is taking a turn. This torque, which represents a friction between the wheels and the ground, forces the two wheels to rotate in the desired velocity ratio.

This external torque ( $T$ ) is to be defined with

$$\begin{aligned} T &= c_f(\omega_o - \omega_r\omega_i) \\ \omega_r &= 1 + 5 \cdot \text{rect1}(\omega t) \end{aligned} \quad (1)$$

where

- $c_f$  is the frictional damping coefficient,
- $\omega_o$  and  $\omega_i$  are the angular velocities of the outer and the inner wheels,
- $\omega_r$  is the velocity ratio between the outer and the inner wheels (set to 1 on a straight path and assumed to be 6 on a curved path), and
- $\omega$  is the angular velocity of the drive shaft.

#### *Results and Discussion*

---

Figure 2 shows a velocity magnitude of the different components in a differential at  $t = 0.125$  sec. At this time instance the vehicle is moving along a straight path. This is also predicted by the model since both axles rotate with the same speed.

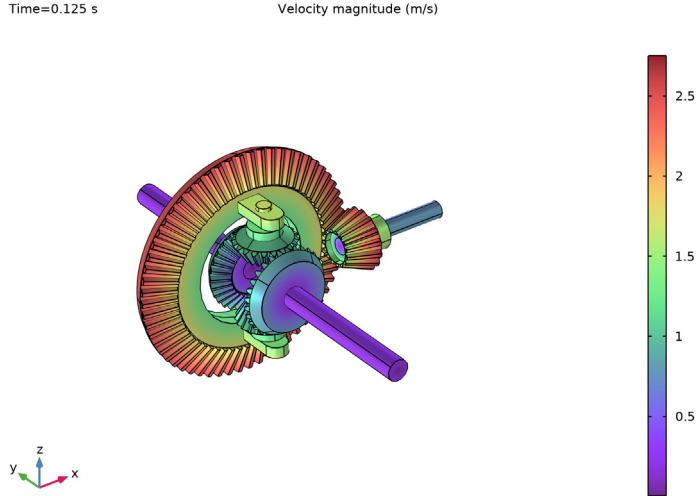

Figure 2: Speed of the different components in a differential after 0.125 s.

Figure 3 shows the velocity  $y$ -component of different differential parts at  $t = 0.08$  sec. At this time instance, the vehicle is moving on a curved path. This is also predicted by the model since the spider gears have a nonzero velocity along the  $y$ -axis, which indicates that besides a planetary motion they are also spinning. The velocity  $y$ -component of the remaining parts is zero as they all rotate about the  $y$ -axis.

The spinning of the spider gears when the vehicle travels on a curved path can be visualized by plotting the relative velocity of the spider gears with respect to the ring gear as shown in Figure 4.

Figure 5 shows the angular velocity of the inner and outer wheels for the two cases when a vehicle moves on a straight path and on a curved path. It can be seen that as soon as the vehicle starts taking a turn, the outer wheel velocity increases and the inner wheel velocity decreases. It happens in such a way that the average is kept constant while the ratio between the two velocity components changes to 6, which is the desired ratio for no slip. Once the vehicle comes back on a straight path, both wheels start rotating with the same speed.

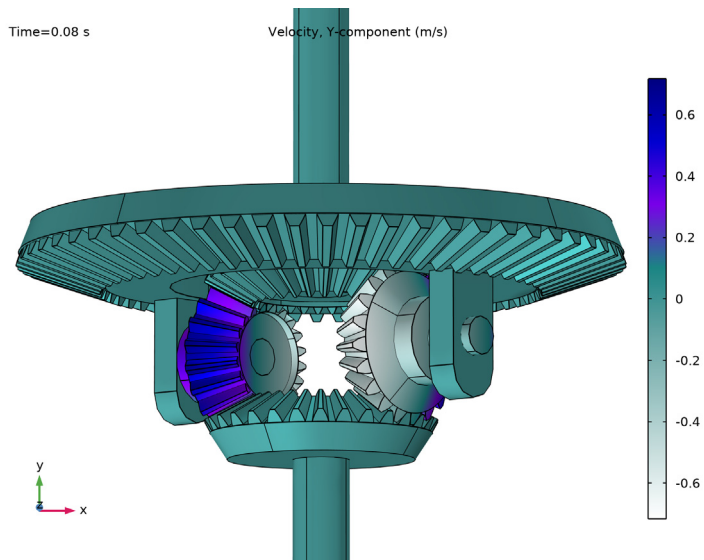

Figure 3: Velocity y-component in different parts of a differential after 0.08 s.

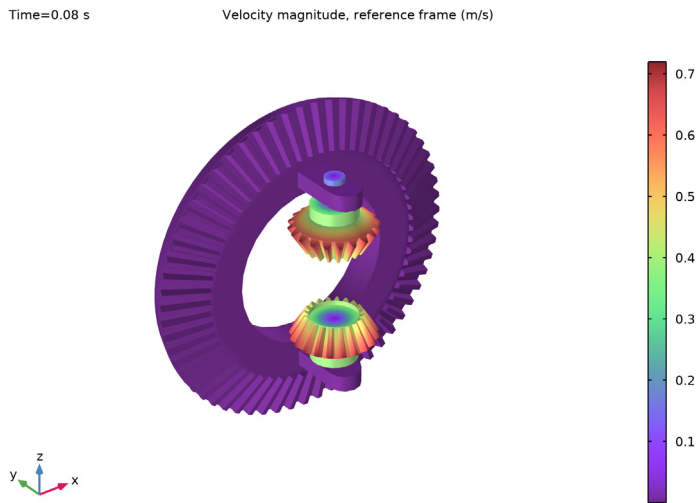

Figure 4: Relative velocity of spider gears with respect to ring gear at 0.08 s.

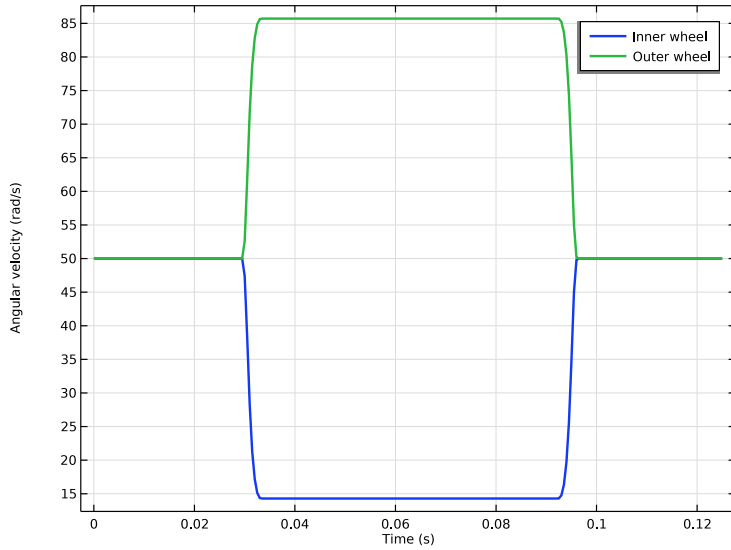

Figure 5: Time variation of the angular velocity of an inner and an outer wheel.

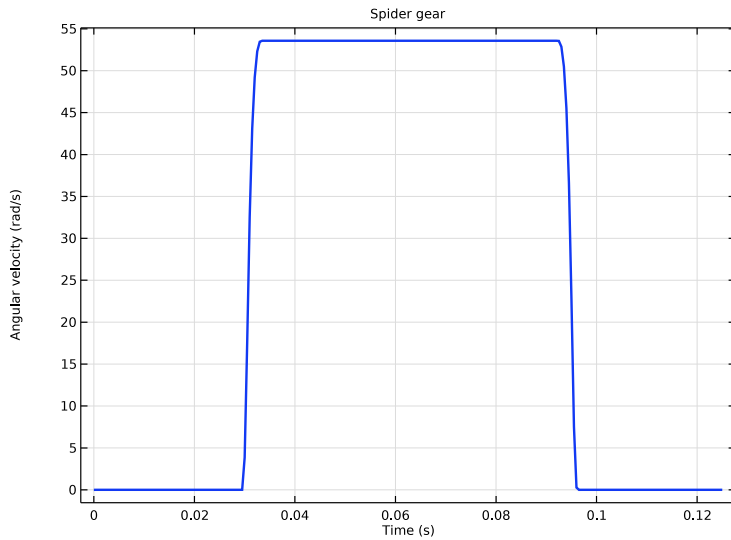

Figure 6: Time variation of the spinning velocity of a spider gears.

Figure 6 shows the spinning velocity of the spider gears. It can be seen that as soon as the vehicle starts taking a turn, the spider gears start spinning. Through this motion it transfers

speed from inner wheel to the outer wheel in such a way that both wheels roll without slip. The spider gears stops spinning, once the vehicle comes back on a straight path.

### *Notes About the COMSOL Implementation*

---

- To build a gear geometry, you can import a gear part from the **Parts Library** and customize it by changing its input parameters. Alternatively, you can also create an equivalent disc or cone to represent the gear.
- All the gears are assumed rigid. The elasticity of a gear mesh can be included on **Gear Pair** nodes using the **Gear Elasticity** subnode.
- All the **Gear Pair** nodes are assumed ideal and frictionless. You can add **Transmission Error**, **Backlash**, or **Friction** subnodes when required.
- To constrain gear motion, you can use **Prescribed Displacement/Rotation** or **Fixed Constraint** subnodes. Alternatively, you can mount gears on a shaft or on the ground through various **Joint** nodes.
- The contact force on a **Gear Pair** is computed using **Weak constraints** or **Penalty method**. By default, the contact force computation is turned off. Use the weak constraints method for more accurate contact forces. However you can switch to the penalty method for large rigid body systems.

---

**Application Library path:** Multibody\_Dynamics\_Module/  
Automotive\_and\_Aerospace/differential\_gear

---

### *Modeling Instructions*



---

From the **File** menu, choose **New**.

#### **NEW**

In the **New** window, click  **Model Wizard**.

#### **MODEL WIZARD**

- 1 In the **Model Wizard** window, click  **3D**.
- 2 In the **Select Physics** tree, select **Structural Mechanics > Multibody Dynamics (mbd)**.
- 3 Click **Add**.
- 4 Click  **Study**.

5 In the **Select Study** tree, select **General Studies > Time Dependent**.

6 Click  **Done**.

## GLOBAL DEFINITIONS

### *Parameters I*

1 In the **Model Builder** window, under **Global Definitions** click **Parameters I**.

2 In the **Settings** window for **Parameters**, locate the **Parameters** section.

3 Click  **Load from File**.

4 Browse to the model's Application Libraries folder and double-click the file `differential_gear_parameters.txt`.

## GEOMETRY I

### *Import I (imp1)*

1 In the **Geometry** toolbar, click  **Import**.

2 In the **Settings** window for **Import**, locate the **Source** section.

3 Click  **Browse**.

4 Browse to the model's Application Libraries folder and double-click the file `differential_gear.mphbin`.

5 Click  **Import**.

### *Form Union (fin)*

1 In the **Model Builder** window, under **Component I (comp1) > Geometry I** click **Form Union (fin)**.

2 In the **Settings** window for **Form Union/Assembly**, locate the **Form Union/Assembly** section.

3 From the **Action** list, choose **Form an assembly**.

4 Clear the **Create pairs** checkbox.

5 In the **Geometry** toolbar, click  **Build All**.



Disable the analysis of the geometry as the remaining small geometric details can be kept.

6 In the **Model Builder** window, click **Geometry I**.

7 In the **Settings** window for **Geometry**, locate the **Cleanup** section.

8 Clear the **Automatic detection of small details** checkbox.

## ADD MATERIAL

- 1 In the **Materials** toolbar, click  **Add Material** to open the **Add Material** window.
- 2 Go to the **Add Material** window.
- 3 In the tree, select **Built-in > Structural steel**.
- 4 Click the **Add to Component** button in the window toolbar.
- 5 In the **Materials** toolbar, click  **Add Material** to close the **Add Material** window.

## MULTIBODY DYNAMICS (MBD)

Add a **Bevel Gear** node and specify its properties.

*Bevel Gear: Pinion*

- 1 In the **Physics** toolbar, click  **Domains** and choose **Bevel Gear**.
- 2 In the **Settings** window for **Bevel Gear**, type Bevel Gear: Pinion in the **Label** text field.
- 3 Select Domain 6 only.
- 4 Locate the **Gear Properties** section. In the  $n$  text field, type  $n_{pn}$ .
- 5 In the  $d_p$  text field, type  $dp_{pn}$ .
- 6 In the  $\alpha$  text field, type  $\alpha$ .
- 7 In the  $\gamma$  text field, type  $\gamma_{pn}$ .
- 8 Locate the **Gear Axis** section. Specify the  $\mathbf{e}_g$  vector as

-1	x
0	y
0	z

- 9 Locate the **Center of Rotation** section. From the list, choose **User defined**.
- 10 Specify the  $\mathbf{X}_c$  vector as

$dp_{rg}/2$	x
$-dp_{pn}/2$	y
0	z

### Bevel Gears

Similarly add 5 more **Bevel Gears** using the information given in the following table:

Name	Selection (Domains)	Number of Teeth	Pitch Diameter	Pressure Angle	Cone Angle
Bevel Gear: Ring Gear	1	n_rg	dp_rg	alpha	gamma_rg
Bevel Gear: Spider Gear 1	5	n_sp	dp_sp	alpha	gamma_sp
Bevel Gear: Spider Gear 2	4	n_sp	dp_sp	alpha	gamma_sp
Bevel Gear: Side Gear 1	3	n_sd	dp_sd	alpha	gamma_sd
Bevel Gear: Side Gear 2	2	n_sd	dp_sd	alpha	gamma_sd

### Bevel Gears

1 Use the axis and center information given in the following table:

Name	Gear Axis	Center of Rotation
Bevel Gear: Ring Gear	(0, -1, 0)	(0, 0, 0)
Bevel Gear: Spider Gear 1	(0, 0, -1)	(0, -d_sp, dp_sd/2)
Bevel Gear: Spider Gear 2	(0, 0, 1)	(0, -d_sp, -dp_sd/2)
Bevel Gear: Side Gear 1	(0, -1, 0)	(0, -d_sp+dp_sp/2, 0)
Bevel Gear: Side Gear 2	(0, 1, 0)	(0, -d_sp-dp_sp/2, 0)

2 In the **Model Builder** window, under **Component 1 (comp1) > Multibody Dynamics (mbd)** click **Bevel Gear: Pinion**.

### Prescribed Displacement/Rotation 1

1 In the **Physics** toolbar, click  **Attributes** and choose **Prescribed Displacement/Rotation**.

2 In the **Settings** window for **Prescribed Displacement/Rotation**, locate the **Prescribed Displacement at Center of Rotation** section.

3 Select the **Prescribed in x direction** checkbox.

4 Select the **Prescribed in y direction** checkbox.

5 Select the **Prescribed in z direction** checkbox.

6 Locate the **Prescribed Rotation** section. From the **By** list, choose **Prescribed rotation**.

7 Specify the  $\Omega$  vector as

-1	x
0	y
0	z

8 In the  $\phi_0$  text field, type  $\omega * t$ .

*Bevel Gear: Ring Gear*

In the **Model Builder** window, under **Component 1 (comp1) > Multibody Dynamics (mbd)** click **Bevel Gear: Ring Gear**.

*Prescribed Displacement/Rotation 1*

- 1 In the **Physics** toolbar, click  **Attributes** and choose **Prescribed Displacement/Rotation**.
- 2 In the **Settings** window for **Prescribed Displacement/Rotation**, locate the **Prescribed Displacement at Center of Rotation** section.
- 3 Select the **Prescribed in x direction** checkbox.
- 4 Select the **Prescribed in y direction** checkbox.
- 5 Select the **Prescribed in z direction** checkbox.
- 6 Locate the **Prescribed Rotation** section. From the **By** list, choose **Constrained rotation**.
- 7 Select the **Constrain rotation around x-axis** checkbox.
- 8 Select the **Constrain rotation around z-axis** checkbox.

*Bevel Gear: Pinion, Bevel Gear: Ring Gear, Bevel Gear: Side Gear 1, Bevel Gear: Side Gear 2, Bevel Gear: Spider Gear 1, Bevel Gear: Spider Gear 2*

- 1 In the **Model Builder** window, under **Component 1 (comp1) > Multibody Dynamics (mbd)**, Ctrl-click to select **Bevel Gear: Pinion, Bevel Gear: Ring Gear, Bevel Gear: Spider Gear 1, Bevel Gear: Spider Gear 2, Bevel Gear: Side Gear 1, and Bevel Gear: Side Gear 2**.
- 2 Right-click and choose **Group**.

*Bevel Gears*

In the **Settings** window for **Group**, type **Bevel Gears** in the **Label** text field.

*Gear Pair 1*

- 1 In the **Physics** toolbar, click  **Global** and choose **Gear Pair**.
- 2 In the **Settings** window for **Gear Pair**, locate the **Gear Selection** section.
- 3 From the **Wheel** list, choose **Bevel Gear: Pinion**.
- 4 From the **Pinion** list, choose **Bevel Gear: Ring Gear**.

### Gear Pairs

Similarly add 4 more **Gear Pairs** using the information given in the following table:

Name	Wheel	Pinion
Gear Pair 2	Bevel Gear: Spider Gear 1	Bevel Gear: Side Gear 1
Gear Pair 3	Bevel Gear: Spider Gear 1	Bevel Gear: Side Gear 2
Gear Pair 4	Bevel Gear: Spider Gear 2	Bevel Gear: Side Gear 1
Gear Pair 5	Bevel Gear: Spider Gear 2	Bevel Gear: Side Gear 2

### Hinge Joint 1

- 1 In the **Physics** toolbar, click  **Global** and choose **Hinge Joint**.
- 2 In the **Settings** window for **Hinge Joint**, locate the **Attachment Selection** section.
- 3 From the **Source** list, choose **Bevel Gear: Ring Gear**.
- 4 From the **Destination** list, choose **Bevel Gear: Spider Gear 1**.
- 5 Locate the **Center of Joint** section. From the list, choose **Centroid of selected entities**.
- 6 From the **Entity level** list, choose **Point**.

### Center of Joint: Point 1

- 1 In the **Model Builder** window, click **Center of Joint: Point 1**.
- 2 In the **Settings** window for **Center of Joint: Point**, locate the **Point Selection** section.
- 3 Click  **Paste Selection**.
- 4 In the **Paste Selection** dialog, type 1528, 1531 in the **Selection** text field.
- 5 Click **OK**.

### Hinge Joint 1

- 1 In the **Model Builder** window, click **Hinge Joint 1**.
- 2 In the **Settings** window for **Hinge Joint**, locate the **Axis of Joint** section.
- 3 Specify the  $\mathbf{e}_0$  vector as

0	x
0	y
1	z

### Hinge Joints

Similarly add 3 more **Hinge Joints** using the information given in the following table:

Name	Source	Destination	Center of Joint (Points)	Axis of Joint
Hinge Joint 2	Bevel Gear: Ring Gear	Bevel Gear: Spider Gear 2	1282, 1341	(0, 0, 1)
Hinge Joint 3	Fixed	Bevel Gear: Side Gear 1	1060, 1061	(0, 1, 0)
Hinge Joint 4	Fixed	Bevel Gear: Side Gear 2	748, 749	(0, 1, 0)

Add a damping force on both side gears (or axles) to prevent the slip on a curved path.

### Hinge Joint 3

In the **Model Builder** window, click **Hinge Joint 3**.

### Applied Force and Moment 1

- 1 In the **Physics** toolbar, click  **Attributes** and choose **Applied Force and Moment**.
- 2 In the **Settings** window for **Applied Force and Moment**, locate the **Applied On** section.
- 3 From the list, choose **Joint**.
- 4 Locate the **Applied Force and Moment** section. In the  $M$  text field, type  $cf*\omega_d$ .

### Hinge Joint 4

In the **Model Builder** window, under **Component 1 (comp1) > Multibody Dynamics (mbd)** click **Hinge Joint 4**.

### Applied Force and Moment 1

- 1 In the **Physics** toolbar, click  **Attributes** and choose **Applied Force and Moment**.
- 2 In the **Settings** window for **Applied Force and Moment**, locate the **Applied On** section.
- 3 From the list, choose **Joint**.
- 4 Locate the **Applied Force and Moment** section. In the  $M$  text field, type  $-cf*\omega_d$ .

### Hinge Joint 1, Hinge Joint 2, Hinge Joint 3, Hinge Joint 4

- 1 In the **Model Builder** window, under **Component 1 (comp1) > Multibody Dynamics (mbd)**, Ctrl-click to select **Hinge Joint 1**, **Hinge Joint 2**, **Hinge Joint 3**, and **Hinge Joint 4**.
- 2 Right-click and choose **Group**.

### Hinge Joints

In the **Settings** window for **Group**, type Hinge Joints in the **Label** text field.

Define the wheel slip in terms of the difference in angular velocity between the outer and the inner wheel.

## DEFINITIONS

### Variables 1

- 1 In the **Model Builder** window, expand the **Component 1 (comp1) > Definitions** node.
- 2 Right-click **Definitions** and choose **Variables**.
- 3 In the **Settings** window for **Variables**, locate the **Variables** section.
- 4 In the table, enter the following settings:

Name	Expression	Unit	Description
omega_i	d(mbd.hgj3.th,t)	rad/s	Angular velocity of inner wheel
omega_o	d(mbd.hgj4.th,t)	rad/s	Angular velocity of outer wheel
omega_r	1+5*rect1(omega*t)		Velocity ratio of outer and inner wheel
omega_d	omega_o-omega_r*omega_i		Velocity difference of outer and inner wheel

### Rectangle 1 (rect1)

- 1 In the **Definitions** toolbar, click  **More Functions** and choose **Rectangle**.
- 2 In the **Settings** window for **Rectangle**, locate the **Parameters** section.
- 3 In the **Lower limit** text field, type  $2\pi$ .
- 4 In the **Upper limit** text field, type  $6\pi$ .
- 5 Click to expand the **Smoothing** section. In the **Size of transition zone** text field, type  $\pi/4$ .

## MESH 1

- 1 In the **Model Builder** window, under **Component 1 (comp1)** click **Mesh 1**.
- 2 In the **Settings** window for **Mesh**, locate the **Physics-Controlled Mesh** section.
- 3 From the **Element size** list, choose **Coarse**.
- 4 Click  **Build All**.

## STUDY 1

### Step 1: Time Dependent

- 1 In the **Model Builder** window, under **Study 1** click **Step 1: Time Dependent**.
- 2 In the **Settings** window for **Time Dependent**, locate the **Study Settings** section.
- 3 In the **Output times** text field, type range  $(0, 5e-4, 0.125)$ .

- 4 In the **Study** toolbar, click  **Compute**.
- 5 Click the  **Show Grid** button in the **Graphics** toolbar.

## RESULTS



### *Displacement (mbd)*

Use the following instructions to plot the speed of the different gears in the differential as shown in [Figure 2](#).

### *Velocity: Magnitude*

- 1 Right-click **Displacement (mbd)** and choose **Duplicate**.
- 2 In the **Settings** window for **3D Plot Group**, type **Velocity: Magnitude** in the **Label** text field.

### *Surface*

- 1 In the **Model Builder** window, expand the **Velocity: Magnitude** node, then click **Surface**.
- 2 In the **Settings** window for **Surface**, locate the **Expression** section.
- 3 In the **Expression** text field, type `mbd.vel`.
- 4 In the **Velocity: Magnitude** toolbar, click  **Plot**.
- 5 Click the  **Zoom Extents** button in the **Graphics** toolbar.

Use the following instructions to plot the rotation of the spider gears about their own axis as shown in [Figure 3](#).

### *Study 1/Solution 1 (2) (sol1)*

- 1 In the **Model Builder** window, expand the **Results > Datasets** node.
- 2 Right-click **Results > Datasets > Study 1/Solution 1 (sol1)** and choose **Duplicate**.

### *Selection*

- 1 In the **Results** toolbar, click  **Attributes** and choose **Selection**.
- 2 In the **Settings** window for **Selection**, locate the **Geometric Entity Selection** section.
- 3 From the **Geometric entity level** list, choose **Domain**.
- 4 Select Domains 1–5 only.

### *Velocity: Y Component*

- 1 In the **Model Builder** window, right-click **Velocity: Magnitude** and choose **Duplicate**.
- 2 In the **Settings** window for **3D Plot Group**, type **Velocity: Y Component** in the **Label** text field.
- 3 Locate the **Data** section. From the **Dataset** list, choose **Study 1/Solution 1 (2) (sol1)**.

- 4 From the **Time (s)** list, choose **0.08**.
- 5 Locate the **Plot Settings** section. From the **View** list, choose **New view**.
- 6 In the **Velocity: Y Component** toolbar, click  **Plot**.

This generates a dedicated view for this plot.

#### *Surface*

- 1 In the **Model Builder** window, expand the **Velocity: Y Component** node, then click **Surface**.
- 2 In the **Settings** window for **Surface**, locate the **Expression** section.
- 3 In the **Expression** text field, type `mbd.u_tY`.
- 4 Locate the **Coloring and Style** section. From the **Color table** list, choose **AuroraAustralis**.
- 5 In the **Velocity: Y Component** toolbar, click  **Plot**.

In order to visualize the motion of the spider gears with respect to the ring gear, you can use the option of defining a reference frame available in the **Multibody Dynamics** interface and plot the postprocessing variables for displacement and velocity with respect to the reference frame.

#### **MULTIBODY DYNAMICS (MBD)**

- 1 In the **Model Builder** window, under **Component 1 (comp1)** click **Multibody Dynamics (mbd)**.
- 2 In the **Settings** window for **Multibody Dynamics**, click to expand the **Results** section.
- 3 From the **Body defining reference frame** list, choose **Bevel Gear: Ring Gear**.

You can update the solution to plot the postprocessing variables available for the new reference frame.

#### **STUDY 1**

In the **Study** toolbar, click  **Update Solution**.

#### **RESULTS**

##### *Study 1/Solution 1 (3) (sol1)*

In the **Model Builder** window, under **Results > Datasets** right-click **Study 1/Solution 1 (2) (sol1)** and choose **Duplicate**.

##### *Selection*

- 1 In the **Model Builder** window, expand the **Study 1/Solution 1 (3) (sol1)** node, then click **Selection**.
- 2 In the **Settings** window for **Selection**, locate the **Geometric Entity Selection** section.

- 3 In the list, choose **2** and **3**.
- 4 Click  **Remove from Selection**.
- 5 Select Domains 1, 4, and 5 only.

*Velocity: Ring Gear Reference*

- 1 In the **Model Builder** window, right-click **Displacement (mbd)** and choose **Duplicate**.
- 2 In the **Model Builder** window, click **Displacement (mbd) 1**.
- 3 In the **Settings** window for **3D Plot Group**, type Velocity: Ring Gear Reference in the **Label** text field.
- 4 Locate the **Data** section. From the **Dataset** list, choose **Study 1/Solution 1 (3) (sol1)**.
- 5 From the **Time (s)** list, choose **0.08**.
- 6 Locate the **Plot Settings** section. Clear the **Plot dataset edges** checkbox.



*Surface*

- 1 In the **Model Builder** window, click **Surface**.
- 2 In the **Settings** window for **Surface**, locate the **Expression** section.
- 3 In the **Expression** text field, type `mbd.vel1_ref`.

*Deformation*

- 1 In the **Model Builder** window, expand the **Surface** node, then click **Deformation**.
- 2 In the **Settings** window for **Deformation**, locate the **Expression** section.
- 3 In the **X-component** text field, type `u_ref`.
- 4 In the **Y-component** text field, type `v_ref`.
- 5 In the **Z-component** text field, type `w_ref`.

*Velocity: Ring Gear Reference*

- 1 In the **Model Builder** window, under **Results** click **Velocity: Ring Gear Reference**.
- 2 In the **Settings** window for **3D Plot Group**, locate the **Plot Settings** section.
- 3 From the **View** list, choose **New view**.
- 4 In the **Velocity: Ring Gear Reference** toolbar, click  **Plot**.
- 5 Click the  **Zoom Extents** button in the **Graphics** toolbar.

Follow the instructions below to plot the angular speed of both the wheels and the spider gears shown in [Figure 5](#) and [Figure 6](#) respectively.

*Angular Velocity: Wheels*

- 1 In the **Results** toolbar, click  **ID Plot Group**.



- 2 In the **Settings** window for **ID Plot Group**, type Angular Velocity: Wheels in the **Label** text field.

#### *Global I*

- 1 Right-click **Angular Velocity: Wheels** and choose **Global**.
- 2 In the **Settings** window for **Global**, click **Replace Expression** in the upper-right corner of the **y-Axis Data** section. From the menu, choose **Component I (comp1) > Multibody Dynamics > Hinge joints > Hinge Joint 3 > mbd.hgj3.th\_t - Relative angular velocity - rad/s**.
- 3 Click **Add Expression** in the upper-right corner of the **y-Axis Data** section. From the menu, choose **Component I (comp1) > Multibody Dynamics > Hinge joints > Hinge Joint 4 > mbd.hgj4.th\_t - Relative angular velocity - rad/s**.
- 4 Click to expand the **Coloring and Style** section. From the **Width** list, choose **2**.
- 5 Click to expand the **Legends** section. From the **Legends** list, choose **Manual**.
- 6 In the table, enter the following settings:

<b>Legends</b>
Inner wheel
Outer wheel



#### *Angular Velocity: Wheels*

- 1 In the **Model Builder** window, click **Angular Velocity: Wheels**.
- 2 In the **Settings** window for **ID Plot Group**, click to expand the **Title** section.
- 3 From the **Title type** list, choose **None**.
- 4 Locate the **Plot Settings** section.
- 5 Select the **y-axis label** checkbox. In the associated text field, type Angular velocity (rad/s).
- 6 In the **Angular Velocity: Wheels** toolbar, click  **Plot**.
- 7 Click the  **Zoom Extents** button in the **Graphics** toolbar.

#### *Angular Velocity: Spider Gear*

- 1 Right-click **Angular Velocity: Wheels** and choose **Duplicate**.
- 2 In the **Settings** window for **ID Plot Group**, type Angular Velocity: Spider Gear in the **Label** text field.
- 3 Locate the **Title** section. From the **Title type** list, choose **Manual**.
- 4 In the **Title** text area, type Spider gear.

### *Global 1*

- 1 In the **Model Builder** window, expand the **Angular Velocity: Spider Gear** node, then click **Global 1**.
- 2 In the **Settings** window for **Global**, click **Replace Expression** in the upper-right corner of the **y-Axis Data** section. From the menu, choose **Component 1 (comp1) > Multibody Dynamics > Hinge joints > Hinge Joint 1 > mbd.hgjl.th\_t - Relative angular velocity - rad/s**.
- 3 Locate the **Legends** section. Clear the **Show legends** checkbox.
- 4 In the **Angular Velocity: Spider Gear** toolbar, click  **Plot**.
- 5 Click the  **Zoom Extents** button in the **Graphics** toolbar.

### *Animation 1*

- 1 In the **Results** toolbar, click  **Animation** and choose **Player**.
- 2 In the **Settings** window for **Animation**, locate the **Scene** section.
- 3 From the **Subject** list, choose **Velocity: Magnitude**.
- 4 Locate the **Frames** section. In the **Number of frames** text field, type 100.

### *Animation 2*

- 1 Right-click **Animation 1** and choose **Duplicate**.
- 2 In the **Settings** window for **Animation**, locate the **Scene** section.
- 3 From the **Subject** list, choose **Velocity: Y Component**.

### *Animation 3*

- 1 Right-click **Animation 2** and choose **Duplicate**.
- 2 In the **Settings** window for **Animation**, locate the **Scene** section.
- 3 From the **Subject** list, choose **Velocity: Ring Gear Reference**.