



Model created in COMSOL Multiphysics 6.4

# Spring-Loaded Centrifugal Governor

## Introduction

---

A centrifugal governor is a device used for controlling the angular speed of rotating machinery. One of the most common applications of centrifugal governors is to control the RPM of an engine by regulating the fuel supply. Power is transferred to the governor through the output shaft of the engine. As the RPM of the engine increase, the governor throttles the fuel supply, thus decreasing the energy input to the engine.

## Model Definition

---

This model demonstrates the modeling of a spring loaded centrifugal governor. The centrifugal governor ([Figure 1](#)) consists of a spindle, two arms, two links, two flyballs, and a sleeve. The spindle is connected to the output shaft of the engine. The arms are connected to the spindle through hinge joints at one end, and flyballs are attached to the other end. The links are connected to the arms and the sleeve through hinge joints.

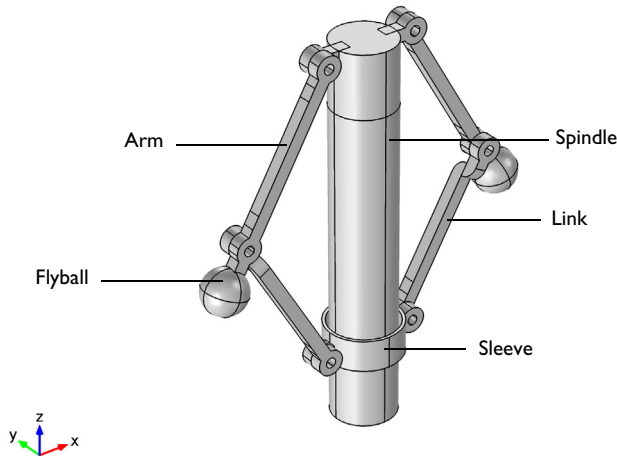

*Figure 1: Geometry of the centrifugal governor.*

Each link is connected to the respective arm and to the sleeve through hinge joints. The sleeve is mounted over the spindle and is free to slide. This is modeled with a prismatic joint. The hinge joint has one rotational degree of freedom, whereas the prismatic joint has one translational degree of freedom along the spindle axis.

In this model, a spring is connected between the sleeve and the spindle to restrict the sleeve's sliding motion. To stabilize the sleeve at its equilibrium position, a dashpot is

attached between the sleeve and the spindle. The spring and the dashpot are available to prismatic joints.

As the spindle rotates with a constant RPM, the centrifugal force makes the arms, links, and flyballs move outward, causing the sleeve to slide on the spindle and move upward.

The spring attached to the sleeve restricts the outward motion, making the sleeve oscillate around an equilibrium position where the net force is zero. This oscillation, caused by inertial effects, is damped by the dashpot.

The equilibrium position of the sleeve is governed by the RPM of the spindle. Once the RPM of the spindle is increased, the sleeve moves to a new equilibrium position.

## Results and Discussion

---

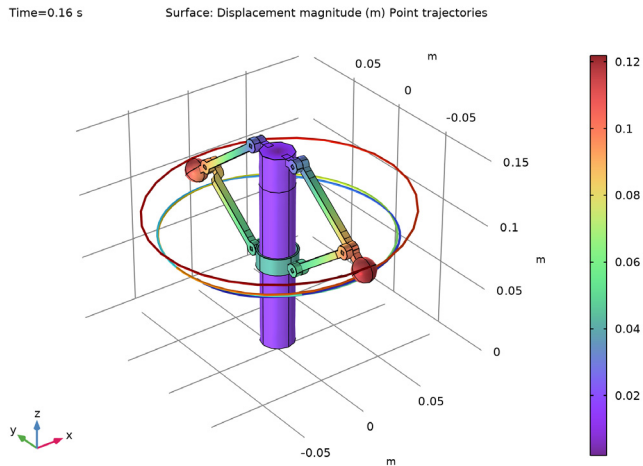

*Figure 2: Displacement of various parts of the centrifugal governor. Trajectory of one of the flyballs is also shown.*

Figure 2 displays the total displacement of all the parts and the trajectory of one of the flyballs at a particular moment. The maximum displacement that can be seen in the flyballs, is the combination of rotational motion and outward motion.

Figure 3 displays the stress generated in the governor components at a particular moment during the operation. The stresses are maximum in the arms and links, and they are concentrated near the joints.

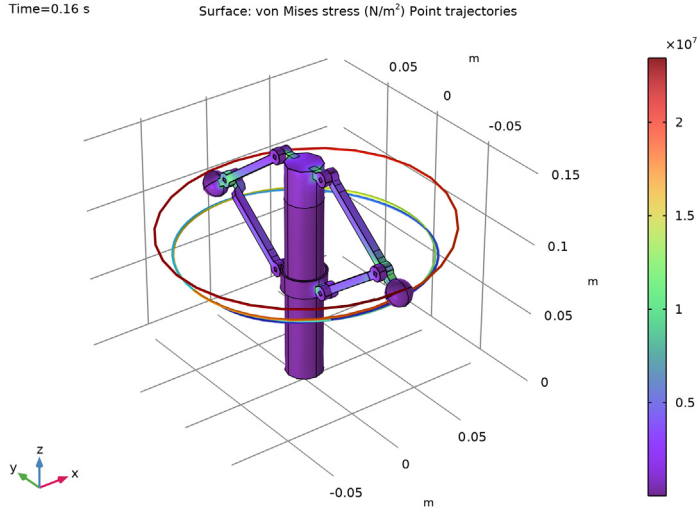

*Figure 3: von Mises stress in the centrifugal governor. Trajectory of one of the flyballs is also shown.*

Figure 4 depicts the displacement of the sleeve with respect to the spindle during operation. The displacement is plotted against the number of revolutions of the spindle. This figure shows how the sleeve moves to an equilibrium position from the initial state. After a few revolutions of the spindle, RPM is gradually doubled and as a result the sleeve moves to a new equilibrium position.

Figure 5 shows the phase portrait of the sleeve's sliding motion. The phase portrait gives more insight about the motion and clearly shows the two equilibrium positions corresponding to the two different RPM values.

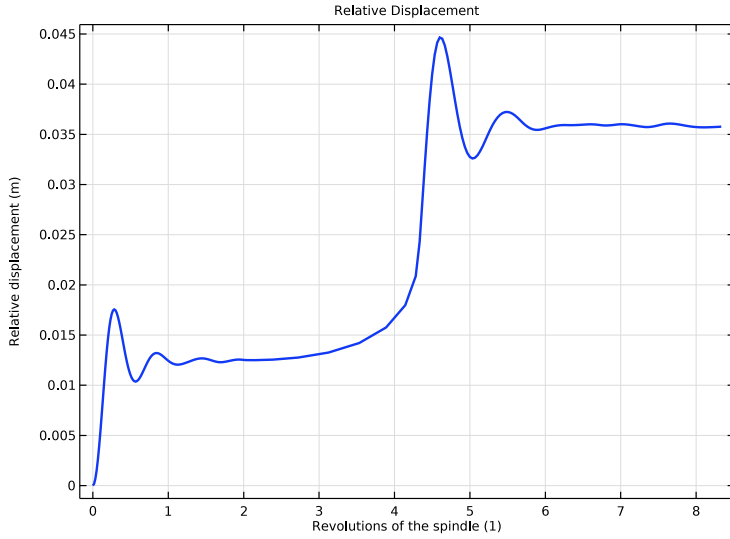

Figure 4: Relative displacement of the sleeve with respect to the spindle.

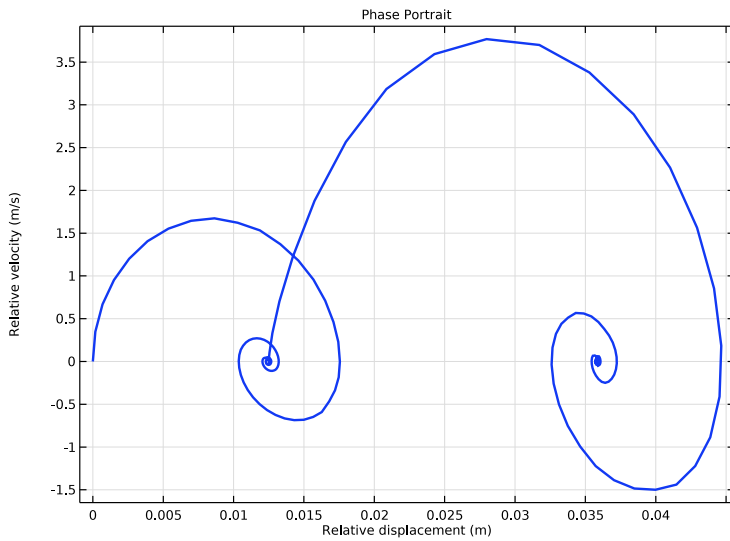
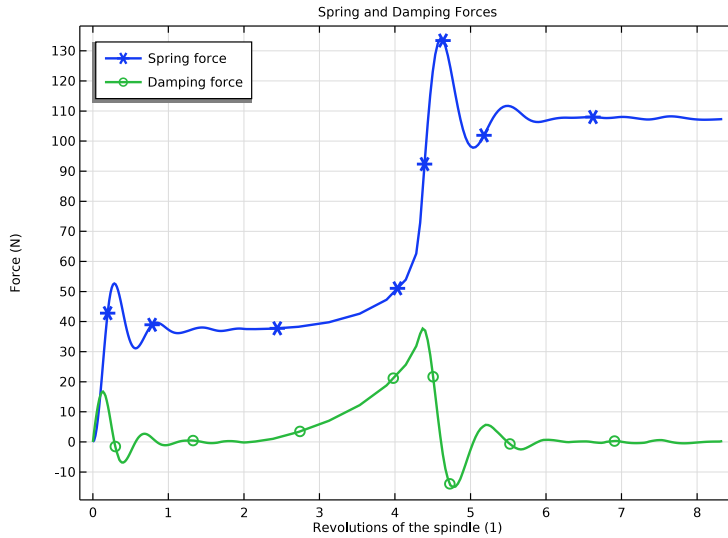

Figure 5: Phase portrait of the sleeve's sliding motion.

The spring and damping forces attached to the sleeve-spindle joint are shown in [Figure 6](#). These forces balance the external force applied on the sleeve due to the centrifugal force on the other governor's parts. It is clear that these forces vary significantly whenever there is a change in speed. The damping force goes to zero whereas the spring force resists the external force.



*Figure 6: Spring and damping force in the spring-dashpot attached between the sleeve and the spindle.*

[Figure 7](#) shows the spatial components of the force in the spindle-arm hinge joint. The  $x$  and  $y$  components have an oscillatory nature and are shifted relatively to each other by a quarter of a revolution. The  $z$  component of the force goes toward a constant value controlled by the RPM. Also, the amplitude of both the  $x$  and  $y$  components changes once the RPM value changes. This demonstrates the change in the force equilibrium of the system.

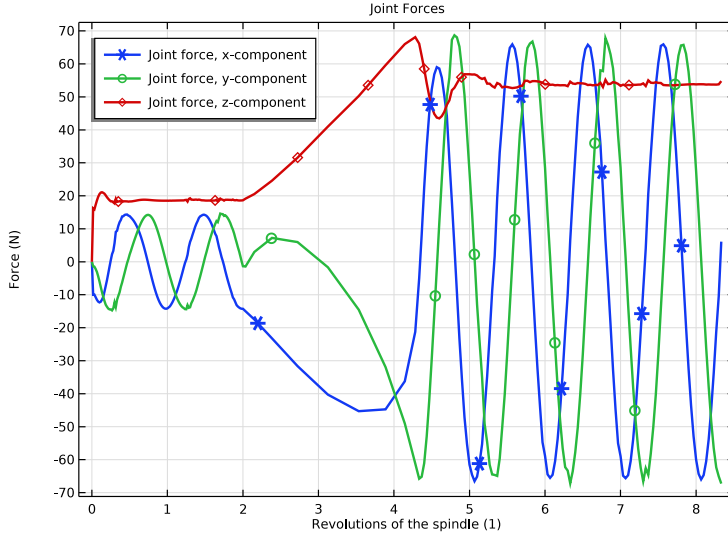

Figure 7: Forces in the hinge joint between the spindle and the arm.

### Notes About the COMSOL Implementation

- In this model, all the components are modeled as flexible elements using the **Linear Elastic Material** node. If the stresses and deformation in the components are not of interest, they can also be modeled as rigid elements using the **Rigid Material** node.
- A **Joint** node can establish a direct connection between **Rigid Material** nodes. However, **Attachment** nodes are needed for flexible elements to define the connecting boundaries.

**Application Library path:** Multibody\_Dynamics\_Module/  
Automotive\_and\_Aerospace/centrifugal\_governor



### Modeling Instructions

From the **File** menu, choose **New**.

#### NEW



In the **New** window, click  **Model Wizard**.

## MODEL WIZARD

- 1 In the **Model Wizard** window, click  **3D**.
- 2 In the **Select Physics** tree, select **Structural Mechanics > Multibody Dynamics (mbd)**.
- 3 Click **Add**.
- 4 Click  **Study**.
- 5 In the **Select Study** tree, select **General Studies > Time Dependent**.
- 6 Click  **Done**.

## GEOMETRY I

### *Import I (impI)*

- 1 In the **Geometry** toolbar, click  **Import**.
- 2 In the **Settings** window for **Import**, locate the **Source** section.
- 3 Click  **Browse**.
- 4 Browse to the model's Application Libraries folder and double-click the file `centrifugal_governor.mphbin`.
- 5 Click  **Import**.

### *Form Union (fin)*

- 1 In the **Model Builder** window, under **Component I (compI) > Geometry I** click **Form Union (fin)**.
- 2 In the **Settings** window for **Form Union/Assembly**, locate the **Form Union/Assembly** section.
- 3 From the **Action** list, choose **Form an assembly**.
- 4 Clear the **Create pairs** checkbox.
- 5 Click  **Build Selected**.

## DEFINITIONS

### *Variables I*

- 1 In the **Definitions** toolbar, click  **Local Variables**.
- 2 In the **Settings** window for **Variables**, locate the **Variables** section.
- 3 In the table, enter the following settings:

Name	Expression	Unit	Description
k	3000[N/m]	N/m	Spring constant
c	10[N*s/m]	N*s/m	Damping coefficient



Name	Expression	Unit	Description
rpm	$1000 * \text{step1}(t)$		RPM of the spindle
omega	$(2 * \pi * \text{rpm} / 60) [\text{rad/s}]$		Angular velocity of the spindle
N	$\text{rpm} / 60 [\text{s}] * t$		Revolutions of the spindle

Use a step function to increase the RPM of the spindle.

#### Step 1 (step1)

- 1 In the **Definitions** toolbar, click  **More Functions** and choose **Step**.
- 2 In the **Settings** window for **Step**, locate the **Parameters** section.
- 3 In the **Location** text field, type 0.125[s].
- 4 In the **From** text field, type 1.
- 5 In the **To** text field, type 2.
- 6 Click to expand the **Smoothing** section. In the **Size of transition zone** text field, type 0.01.

#### ADD MATERIAL

- 1 In the **Materials** toolbar, click  **Add Material** to open the **Add Material** window.
- 2 Go to the **Add Material** window.
- 3 In the tree, select **Built-in > Structural steel**.
- 4 Click the **Add to Component** button in the window toolbar.
- 5 In the **Materials** toolbar, click  **Add Material** to close the **Add Material** window.

#### MULTIBODY DYNAMICS (MBD)

To avoid transient effects, the governor is initialized to rotate about the  $z$ -axis.

- 1 In the **Settings** window for **Multibody Dynamics**, click to expand the **Initial Values** section.
- 2 Specify the  $\omega$  vector as

0	x
0	y
omega	z

#### Attachment 1

- 1 In the **Physics** toolbar, click  **Boundaries** and choose **Attachment**.
- 2 Select Boundaries 119, 120, 127, and 129 only.

### Attachments

You can create the remaining attachments using the information given in the table below:

Name	Selection
Attachment 2	89, 90, 92, 93
Attachment 3	101, 102, 104, 105
Attachment 4	191-193, 195
Attachment 5	210-212, 214
Attachment 6	166-168, 170, 177, 178
Attachment 7	138, 139, 141, 142
Attachment 8	149-151, 153
Attachment 9	36, 37, 39, 41
Attachment 10	111, 112, 114, 115
Attachment 11	16-19, 22, 24
Attachment 12	48-50, 52
Attachment 13	66, 67, 69, 71
Attachment 14	77, 78, 80, 81

*Attachment 1, Attachment 10, Attachment 11, Attachment 12, Attachment 13, Attachment 14, Attachment 2, Attachment 3, Attachment 4, Attachment 5, Attachment 6, Attachment 7, Attachment 8, Attachment 9*

**1** In the **Model Builder** window, under **Component 1 (comp1) > Multibody Dynamics (mbd)**, Ctrl-click to select **Attachment 1, Attachment 2, Attachment 3, Attachment 4, Attachment 5, Attachment 6, Attachment 7, Attachment 8, Attachment 9, Attachment 10, Attachment 11, Attachment 12, Attachment 13**, and **Attachment 14**.

**2** Right-click and choose **Group**.

### Attachments

In the **Settings** window for **Group**, type Attachments in the **Label** text field.

### Prismatic Joint 1

**1** In the **Physics** toolbar, click  **Global** and choose **Prismatic Joint**.

**2** In the **Settings** window for **Prismatic Joint**, locate the **Attachment Selection** section.

**3** From the **Source** list, choose **Attachment 1**.

**4** From the **Destination** list, choose **Attachment 2**.

5 Locate the **Axis of Joint** section. Specify the  $\mathbf{e}_0$  vector as

0	x
0	y
1	z

#### *Spring and Damper 1*

- 1 In the **Physics** toolbar, click  **Attributes** and choose **Spring and Damper**.
- 2 In the **Settings** window for **Spring and Damper**, locate the **Spring and Damper: Translational** section.
- 3 In the  $k_u$  text field, type k.
- 4 In the  $c_u$  text field, type c.

#### *Hinge Joint 1*

- 1 In the **Physics** toolbar, click  **Global** and choose **Hinge Joint**.
- 2 In the **Settings** window for **Hinge Joint**, locate the **Attachment Selection** section.
- 3 From the **Source** list, choose **Attachment 3**.
- 4 From the **Destination** list, choose **Attachment 4**.
- 5 Locate the **Axis of Joint** section. Specify the  $\mathbf{e}_0$  vector as

0	x
1	y
0	z

#### *Hinge Joint 2*

- 1 Right-click **Hinge Joint 1** and choose **Duplicate**.
- 2 In the **Settings** window for **Hinge Joint**, locate the **Attachment Selection** section.
- 3 From the **Source** list, choose **Attachment 5**.
- 4 From the **Destination** list, choose **Attachment 6**.

#### *Hinge Joint 3*

- 1 Right-click **Hinge Joint 2** and choose **Duplicate**.
- 2 In the **Settings** window for **Hinge Joint**, locate the **Attachment Selection** section.
- 3 From the **Source** list, choose **Attachment 7**.
- 4 From the **Destination** list, choose **Attachment 8**.

#### *Hinge Joint 4*

- 1 Right-click **Hinge Joint 3** and choose **Duplicate**.
- 2 In the **Settings** window for **Hinge Joint**, locate the **Attachment Selection** section.
- 3 From the **Source** list, choose **Attachment 9**.
- 4 From the **Destination** list, choose **Attachment 10**.

#### *Hinge Joint 5*

- 1 Right-click **Hinge Joint 4** and choose **Duplicate**.
- 2 In the **Settings** window for **Hinge Joint**, locate the **Attachment Selection** section.
- 3 From the **Source** list, choose **Attachment 11**.
- 4 From the **Destination** list, choose **Attachment 12**.

#### *Hinge Joint 6*

- 1 Right-click **Hinge Joint 5** and choose **Duplicate**.
- 2 In the **Settings** window for **Hinge Joint**, locate the **Attachment Selection** section.
- 3 From the **Source** list, choose **Attachment 13**.
- 4 From the **Destination** list, choose **Attachment 14**.

Use a Hinge Joint node with a Prescribed Motion subnode to model the rotation of the spindle.

#### *Hinge Joint 7*

- 1 Right-click **Hinge Joint 6** and choose **Duplicate**.
- 2 In the **Settings** window for **Hinge Joint**, locate the **Attachment Selection** section.
- 3 From the **Source** list, choose **Fixed**.
- 4 From the **Destination** list, choose **Attachment 1**.
- 5 Locate the **Axis of Joint** section. Specify the  $\mathbf{e}_0$  vector as

0	x
0	y
1	z

#### *Prescribed Motion 1*

- 1 In the **Physics** toolbar, click  **Attributes** and choose **Prescribed Motion**.
- 2 In the **Settings** window for **Prescribed Motion**, locate the **Prescribed Rotational Motion** section.
- 3 From the **Prescribed motion through** list, choose **Angular velocity**.

4 In the  $\omega_p$  text field, type omega.

*Hinge Joint 1, Hinge Joint 2, Hinge Joint 3, Hinge Joint 4, Hinge Joint 5, Hinge Joint 6, Hinge Joint 7, Prismatic Joint 1*

1 In the **Model Builder** window, under **Component 1 (comp1) > Multibody Dynamics (mbd)**, Ctrl-click to select **Prismatic Joint 1, Hinge Joint 1, Hinge Joint 2, Hinge Joint 3, Hinge Joint 4, Hinge Joint 5, Hinge Joint 6, and Hinge Joint 7.**

2 Right-click and choose **Group**.

*Joints*

In the **Settings** window for **Group**, type Joints in the **Label** text field.

### **MESH 1**

1 In the **Model Builder** window, under **Component 1 (comp1)** click **Mesh 1**.

2 In the **Settings** window for **Mesh**, locate the **Physics-Controlled Mesh** section.

3 From the **Element size** list, choose **Coarse**.

4 In the table, clear the **Use** checkbox for **Geometric Analysis, Detail Size**.

Use a finer mesh to get a more accurate solution.

### **STUDY 1**

*Step 1: Time Dependent*

1 In the **Model Builder** window, under **Study 1** click **Step 1: Time Dependent**.

2 In the **Settings** window for **Time Dependent**, locate the **Study Settings** section.

3 In the **Output times** text field, type range (0,0.001,0.25).

*Solution 1 (sol1)*

1 In the **Study** toolbar, click  **Show Default Solver**.

2 In the **Model Builder** window, expand the **Solution 1 (sol1)** node, then click **Time-Dependent Solver 1**.

3 In the **Settings** window for **Time-Dependent Solver**, click to expand the **Absolute Tolerance** section.

4 From the **Tolerance method** list, choose **Manual**.

5 Click to expand the **Time Stepping** section. From the **Steps taken by solver** list, choose **Free**.

6 From the **Maximum step constraint** list, choose **Constant**.

- 7 In the **Maximum step** text field, type 0.005.  
Switching off the consistent initialization helps the simulation to start more smoothly. This also avoids high initial forces due to inconsistent initial values.
- 8 Click to expand the **Advanced** section. Locate the **Time Stepping** section. Find the **Algebraic variable settings** subsection. From the **Consistent initialization** list, choose **Off**.
- 9 In the **Study** toolbar, click  **Compute**.

## RESULTS

Follow these instructions to generate the displacement plot shown in [Figure 2](#):

### *Displacement (mbd)*

- 1 In the **Model Builder** window, under **Results** click **Displacement (mbd)**.
- 2 In the **Settings** window for **3D Plot Group**, locate the **Data** section.
- 3 From the **Time (s)** list, choose **0.16**.



### *Point Trajectories I*

- 1 In the **Displacement (mbd)** toolbar, click  **More Plots** and choose **Point Trajectories**.
- 2 Select Point 1 only.
- 3 In the **Settings** window for **Point Trajectories**, locate the **Coloring and Style** section.
- 4 Find the **Line style** subsection. From the **Type** list, choose **Tube**.

### *Color Expression I*

- 1 Right-click **Point Trajectories I** and choose **Color Expression**.
- 2 In the **Settings** window for **Color Expression**, locate the **Expression** section.
- 3 In the **Expression** text field, type  $t$ .
- 4 Locate the **Coloring and Style** section. Clear the **Color legend** checkbox.

### *Displacement (mbd)*

- 1 Click the  **Zoom Extents** button in the **Graphics** toolbar.
- 2 In the **Model Builder** window, under **Results** click **Displacement (mbd)**.
- 3 In the **Displacement (mbd)** toolbar, click  **Plot**.

Follow these instructions to generate the stress plot shown in [Figure 3](#):

### *Stress*

- 1 Right-click **Displacement (mbd)** and choose **Duplicate**.
- 2 In the **Settings** window for **3D Plot Group**, type Stress in the **Label** text field.

### Surface

- 1 In the **Model Builder** window, expand the **Stress** node, then click **Surface**.
- 2 In the **Settings** window for **Surface**, click **Replace Expression** in the upper-right corner of the **Expression** section. From the menu, choose **Component 1 (comp1) > Multibody Dynamics > Stress > mbd.misesGp - von Mises stress - N/m<sup>2</sup>**.
- 3 In the **Stress** toolbar, click  **Plot**.

Use the following instructions to generate a plot for the relative displacement of the sleeve as given in [Figure 4](#):

### Relative Displacement

- 1 In the **Results** toolbar, click  **ID Plot Group**.
- 2 In the **Settings** window for **ID Plot Group**, type Relative Displacement in the **Label** text field.
- 3 Click to expand the **Title** section. From the **Title type** list, choose **Label**.

### Global 1

- 1 Right-click **Relative Displacement** and choose **Global**.
- 2 In the **Settings** window for **Global**, click **Replace Expression** in the upper-right corner of the **y-Axis Data** section. From the menu, choose **Component 1 (comp1) > Multibody Dynamics > Prismatic joints > Prismatic Joint 1 > mbd.prj1.u - Relative displacement - m**.
- 3 Click to expand the **Title** section. From the **Title type** list, choose **None**.
- 4 Click to expand the **Legends** section. Clear the **Show legends** checkbox.
- 5 Click to expand the **Coloring and Style** section. From the **Width** list, choose **2**.
- 6 Locate the **x-Axis Data** section. From the **Parameter** list, choose **Expression**.
- 7 In the **Expression** text field, type  $N$ .

### Relative Displacement

- 1 In the **Model Builder** window, click **Relative Displacement**.
- 2 In the **Relative Displacement** toolbar, click  **Plot**.

Use the following instructions to generate a phase portrait of the sleeve motion as given in [Figure 5](#):

### Phase Portrait

- 1 In the **Results** toolbar, click  **ID Plot Group**.
- 2 In the **Settings** window for **ID Plot Group**, type Phase Portrait in the **Label** text field.

- 3 Locate the **Title** section. From the **Title type** list, choose **Label**.

#### *Global 1*

- 1 Right-click **Phase Portrait** and choose **Global**.
- 2 In the **Settings** window for **Global**, click **Replace Expression** in the upper-right corner of the **y-Axis Data** section. From the menu, choose **Component 1 (comp1) > Multibody Dynamics > Prismatic joints > Prismatic Joint 1 > mbd.prj1.u\_t - Relative velocity - m/s**.
- 3 Locate the **Title** section. From the **Title type** list, choose **Manual**.
- 4 In the **Title** text area, type Phase portrait.
- 5 Locate the **Legends** section. Clear the **Show legends** checkbox.
- 6 Locate the **Coloring and Style** section. From the **Width** list, choose 2.
- 7 Locate the **x-Axis Data** section. From the **Parameter** list, choose **Expression**.
- 8 In the **Expression** text field, type `mbd.prj1.u`.

#### *Phase Portrait*

- 1 In the **Model Builder** window, click **Phase Portrait**.
- 2 In the **Phase Portrait** toolbar, click  **Plot**.

Follow these instructions to generate a plot for the spring and damping forces as given in [Figure 6](#):

#### *Spring and Damping Forces*

- 1 In the **Results** toolbar, click  **ID Plot Group**.
- 2 In the **Settings** window for **ID Plot Group**, type Spring and Damping Forces in the **Label** text field.
- 3 Locate the **Plot Settings** section.
- 4 Select the **y-axis label** checkbox. In the associated text field, type Force (N).
- 5 Locate the **Title** section. From the **Title type** list, choose **Label**.
- 6 Locate the **Legend** section. From the **Position** list, choose **Upper left**.

#### *Global 1*

- 1 Right-click **Spring and Damping Forces** and choose **Global**.
- 2 In the **Settings** window for **Global**, locate the **y-Axis Data** section.

3 In the table, enter the following settings:

Expression	Unit	Description
mbd.prj1.sd1.Fs	N	Spring force
mbd.prj1.sd1.Fd	N	Damping force

4 Locate the **x-Axis Data** section. From the **Parameter** list, choose **Expression**.

5 In the **Expression** text field, type N.

6 Locate the **Coloring and Style** section. From the **Width** list, choose **2**.

7 Find the **Line markers** subsection. From the **Marker** list, choose **Cycle**.

8 From the **Positioning** list, choose **Interpolated**.

9 In the **Spring and Damping Forces** toolbar, click  **Plot**.

Follow these instructions to generate a plot of the forces in the joint between the spindle and the arm, as shown in [Figure 7](#):

#### *Joint Forces*

1 In the **Results** toolbar, click  **ID Plot Group**.

2 In the **Settings** window for **ID Plot Group**, type Joint Forces in the **Label** text field.

3 Locate the **Title** section. From the **Title type** list, choose **Label**.

4 Locate the **Plot Settings** section.

5 Select the **y-axis label** checkbox. In the associated text field, type Force (N).

6 Locate the **Legend** section. From the **Position** list, choose **Upper left**.

#### *Global I*

1 Right-click **Joint Forces** and choose **Global**.

2 In the **Settings** window for **Global**, click **Replace Expression** in the upper-right corner of the **y-Axis Data** section. From the menu, choose **Component 1 (comp1) > Multibody Dynamics > Hinge joints > Hinge Joint 3 > Joint force - N > mbd.hgj3.Fx - Joint force, x-component**.

3 Click **Add Expression** in the upper-right corner of the **y-Axis Data** section. From the menu, choose **Component 1 (comp1) > Multibody Dynamics > Hinge joints > Hinge Joint 3 > Joint force - N > mbd.hgj3.Fy - Joint force, y-component**.

4 Click **Add Expression** in the upper-right corner of the **y-Axis Data** section. From the menu, choose **Component 1 (comp1) > Multibody Dynamics > Hinge joints > Hinge Joint 3 > Joint force - N > mbd.hgj3.Fz - Joint force, z-component**.

5 Locate the **x-Axis Data** section. From the **Parameter** list, choose **Expression**.

- 6 In the **Expression** text field, type N.
- 7 Locate the **Coloring and Style** section. From the **Width** list, choose **2**.
- 8 Find the **Line markers** subsection. From the **Marker** list, choose **Cycle**.
- 9 From the **Positioning** list, choose **Interpolated**.
- 10 In the **Joint Forces** toolbar, click  **Plot**.

Finally, generate an animation of the stress distribution in the centrifugal governor during its operation.

#### *Animation 1*

- 1 In the **Results** toolbar, click  **Animation** and choose **Player**.
- 2 In the **Settings** window for **Animation**, locate the **Scene** section.
- 3 From the **Subject** list, choose **Stress**.
- 4 Locate the **Frames** section. In the **Number of frames** text field, type 100.