



Model created in COMSOL Multiphysics 6.4

# 1D Lithium-Ion Battery Model Charge Control

## *Introduction*

---

Charge controllers are useful to improve battery lifetime as they prevent overcharging and possible overvoltage. This model combines the electrochemistry simulation in COMSOL Multiphysics with a control system implemented in Simulink. The control system adjusts the electric current during the charge phase to prevent overvoltage. The electric current is also controlled in the discharge phase to ensure constant power.

---

**Note:** This models requires licenses for both the Battery Design Module and LiveLink™ for Simulink®.

---

## *Model Definition*

---

The simulation consists of controlling the current in a lithium-ion battery in different cases. In charging mode, the voltage is limited to a maximum value of 4 V. In use, the battery is requested to provide a constant power of 5 W. When the voltage reaches a minimum value of 3.1 V, the current is cut to prevent possible battery damage.

The control system diagram is implemented in Simulink, while the battery's electrochemical model is computed in COMSOL Multiphysics. Both programs can run together by means of a COMSOL Cosimulation block in the simulation diagram.

The battery cell model is created using the Lithium-Ion Battery interface in COMSOL Multiphysics. A more detailed description on how to set up this type of model can be found in the model example *1D Lithium-Ion Battery Model for the SEI Formation Tutorial* in the Battery Design Module Application Library.

The cosimulation with COMSOL Multiphysics and Simulink is set up by exporting a COMSOL Cosimulation file from the COMSOL model, and then adding this to the COMSOL Cosimulation block in the Simulink simulation diagram. The input of the block consists in the applied current, provided by Simulink. The block output is the cell voltage.

[Figure 1](#) below shows the controller diagram implementation in Simulink for both charging and discharging phase.

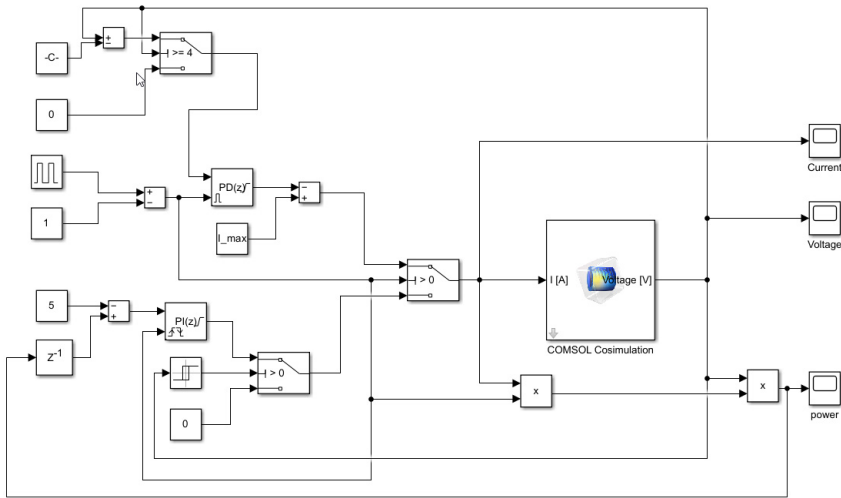
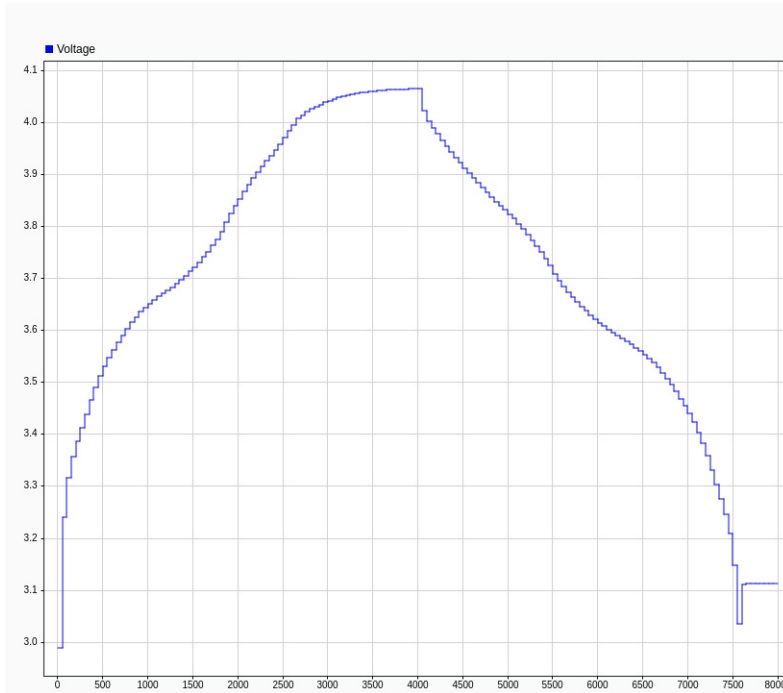

Figure 1: Charge/discharge control diagram of a battery cosimulation in Simulink.

## Results and Discussion

Figure 2 shows the battery voltage variation during the charging and discharging phases.



*Figure 2: Battery voltage during charge and discharge.*

Figure 3 shows the current in the battery. At the beginning, a constant current of 1.6 A ensures maximal charging. Then, to prevent battery damage, the current is dropped to limit the voltage until full charge. During discharge, the current is adjusted to ensure a utility power of 5 W.

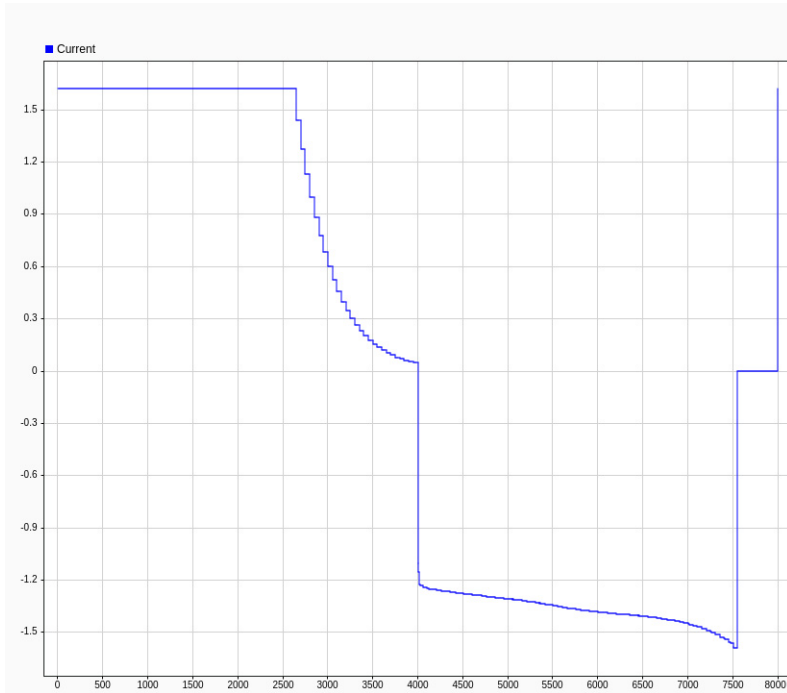

*Figure 3: Battery current during charge and discharge.*

Figure 4 shows the battery power. You can notice the effect of the PI controller that ensure a constant utility power set to 5W.

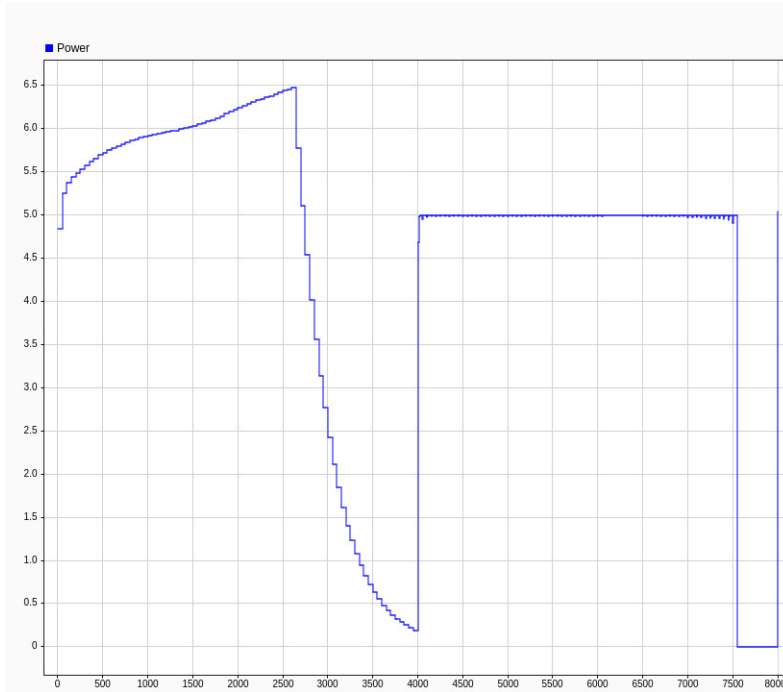

*Figure 4: Battery power during charge and discharge.*

### *Setting Up the Cosimulation*

---

Follow the workflow below to set up the cosimulation with COMSOL Multiphysics and Simulink:

- 1 Set up the COMSOL model and make sure that the study runs. Only studies with a single Stationary or Time Dependent study step are supported for cosimulation.
- 2 Save the COMSOL model. This step is important because the name of the model is needed to load the cosimulation file in Simulink.
- 3 Add the Cosimulation for Simulink feature node to the COMSOL model. Use this to define the inputs, outputs, and study for the cosimulation.

- 4 From the Cosimulation for Simulink feature node, export the file for cosimulation. Any location will work, but it is good practice to export this file to the location where the MPH-file has been saved.
- 5 Create or load the simulation diagram in Simulink, and add the COMSOL Cosimulation block.
- 6 Double-click the COMSOL Cosimulation block, and enter the name of the cosimulation file exported from COMSOL Multiphysics.

---

**Application Library path:** LiveLink\_for\_Simulink/Tutorials/li\_battery\_llsimulink

---

### *Modeling Instructions — COMSOL Desktop*

---

Start this tutorial by opening a seed file that contains a 1D battery model, without any SEI formation reactions or mechanisms added.

#### **APPLICATION LIBRARIES**

- 1 From the **File** menu, choose **Application Libraries**.
- 2 In the **Application Libraries** window, select **Battery Design Module > Lithium-Ion Batteries, Aging and Abuse > sei\_formation\_seed** in the tree.
- 3 Click  **Open**.

#### *Parameters*

- 1 In the **Model Builder** window, under **Global Definitions** click **Parameters 1**.
- 2 In the **Settings** window for **Parameters**, locate the **Parameters** section.
- 3 In the table, append the following settings:

<b>Name</b>	<b>Expression</b>	<b>Value</b>	<b>Description</b>
E_cell_100SOC	4[V]	4 V	Cell voltage at 100% SOC
E_cell_0SOC	3[V]	3 V	Cell voltage at 0% SOC
E_max	4[V]	4 V	Maximum cell voltage in cycling protocol
E_min	3[V]	3 V	Minimum cell voltage in cycling protocol
I	0[A]	0 A	Input current
Ac	0.1[m^2]	0.1 M2	Cross-sectional area

## LITHIUM-ION BATTERY (LIION)

- 1 In the **Model Builder** window, expand the **Component 1 (comp1)** node, then click **Lithium-Ion Battery (liion)**.
- 2 In the **Settings** window for **Lithium-Ion Battery**, locate the **Cross-Sectional Area** section.
- 3 In the  $A_c$  text field, type  $A_c$ .

### *Electrode Current I*

- 1 In the **Model Builder** window, expand the **Lithium-Ion Battery (liion)** node.
- 2 Right-click **Lithium-Ion Battery (liion)** and choose **Electrode Phase > Electrode Current**.
- 3 Select Boundary 4 only.
- 4 In the **Settings** window for **Electrode Current**, locate the **Electrode Current** section.
- 5 In the  $I_{s,total}$  text field, type  $I$ .
- 6 In the  $\phi_{s,bnd,init}$  text field, type  $E_{min}$ .

## DEFINITIONS

### *Integration I (intop1)*

- 1 In the **Definitions** toolbar, click  **Nonlocal Couplings** and choose **Integration**.
- 2 In the **Settings** window for **Integration**, locate the **Source Selection** section.
- 3 From the **Geometric entity level** list, choose **Boundary**.
- 4 Select Boundary 1 only.

### *Variables I*

- 1 In the **Model Builder** window, click **Variables I**.
- 2 In the **Settings** window for **Variables**, locate the **Variables** section.
- 3 In the table, replace the settings for  $I_{cell}$  and  $E_{cell}$  with the following:

Name	Expression	Unit	Description
$I_{cell}$	$intop1(reacf(phil)) * 1[A]$	A	Cell current
$E_{cell}$	$liion.phis0_{ec1}$	V	Cell voltage

To define the cosimulation block output you need to create first a global variable probe.

### *Global Variable Probe I (var1)*



- 1 In the **Definitions** toolbar, click  **Probes** and choose **Global Variable Probe**.
- 2 In the **Settings** window for **Global Variable Probe**, type  $voltage$  in the **Variable name** text field.
- 3 Locate the **Expression** section. In the **Expression** text field, type  $E_{cell}$ .

## STUDY 1

### *Step 2: Time Dependent*

- 1 In the **Model Builder** window, under **Study 1** right-click **Step 2: Time Dependent** and choose **Delete**.
- 2 In the **Study** toolbar, click  **Compute**.

## ADD STUDY

- 1 In the **Home** toolbar, click  **Add Study** to open the **Add Study** window.
- 2 Go to the **Add Study** window.
- 3 Find the **Studies** subsection. In the **Select Study** tree, select **General Studies** > **Time Dependent**.
- 4 Right-click and choose **Add Study**.
- 5 In the **Home** toolbar, click  **Add Study** to close the **Add Study** window.

## STUDY 2

### *Step 1: Time Dependent*

- 1 In the **Settings** window for **Time Dependent**, locate the **Study Settings** section.
- 2 In the **Output times** text field, type range (0, 180, 3800).
- 3 Click to expand the **Values of Dependent Variables** section. Find the **Initial values of variables solved for** subsection. From the **Settings** list, choose **User controlled**.
- 4 From the **Method** list, choose **Solution**.
- 5 From the **Study** list, choose **Study 1, Current Distribution Initialization**.
- 6 In the **Study** toolbar, click  **Compute**.

## SAVE THE COMSOL MODEL

- 1 In the **Model Builder** window, under **Results** click **Probe Plot Group 2**.
- 2 From the **File** menu, choose **Save As**.
- 3 Browse to a suitable folder, enter the filename `li_battery_11simulink.mph`, and then click **Save**.



### *Exporting the Cosimulation File*

---

In the following configure the cosimulation, and export the file for cosimulation that will be loaded into Simulink.

## GLOBAL DEFINITIONS

### *Cosimulation for Simulink 1*

- 1 In the **Study** toolbar, click  **Cosimulation for Simulink**.
- 2 In the **Settings** window for **Cosimulation for Simulink**, locate the **Filename** section.
- 3 In the **Filename** text field, type `li_battery_llsimulink`.
- 4 Locate the **Inputs** section. Click  **Add**.
- 5 In the table, enter the following settings:

Parameter name	Initial value	Unit
I (Input current)	1.621 [A]	A

- 6 Locate the **Outputs** section. In the table, enter the following settings:

Expression	Unit	Name
comp1.voltage	V	Voltage

- 7 Click  **Export**.

### *Modeling Instructions — Simulink*

Once you have created the COMSOL model and saved the cosimulation file you can start Simulink to continue with the setup there.

- 1 Start COMSOL with Simulink.
- 2 In MATLAB enter the command `mphapplicationlibraries` to start the GUI for viewing models from the LiveLink for Simulink application library.
- 3 Browse to the folder `LiveLink_for_Simulink/Tutorials`, and select `li_battery_llsimulink.slx`.
- 4 Click **Open** to get the simulation diagram as in [Figure 1](#).

The included COMSOL Cosimulation block is already configured with a cosimulation file based on the model from the COMSOL Application Library and ready to run. If you want to run the simulation directly, go to Step 7 below. Else, if you want to use the model file and cosimulation file you have created by following the steps in the section [Modeling Instructions — COMSOL Desktop](#), you can continue with Step 5 below.

- 5 Double-click the COMSOL Cosimulation block.

- 6 In the COMSOL Cosimulation window settings, in the Filename edit field enter the name of the file for cosimulation for Simulink as created in the section Exporting File for Cosimulation for Simulink.

---

**Note:** In case the folder path of the file for cosimulation for Simulink is not set in MATLAB enter the full filename.

---

For this simulation the stop time is set to 8,000 s and the communication step size is set to 50 s.

- 7 To run the simulation, click Run.