



Model created in COMSOL Multiphysics 6.4

Geometric Parameter Optimization of a Tuning Fork

Introduction

Tuning forks have traditionally been used for tuning of musical instruments due to their ability to sound a very pure tone at their fundamental eigenfrequency. To design a tuning fork that sounds the note A, 440 Hz, you first compute the fundamental eigenfrequency and eigenmode for a design with a prong length estimated from theory. Then you use geometric parameter optimization to fine tune the prong size so that the fundamental eigenfrequency corresponds to 440 Hz.

Model Definition

The model geometry is shown in [Figure 1](#). The fundamental frequency of the fork is determined by the length of the prongs, the cross-sectional geometry of the prongs, and the material properties of the fork.

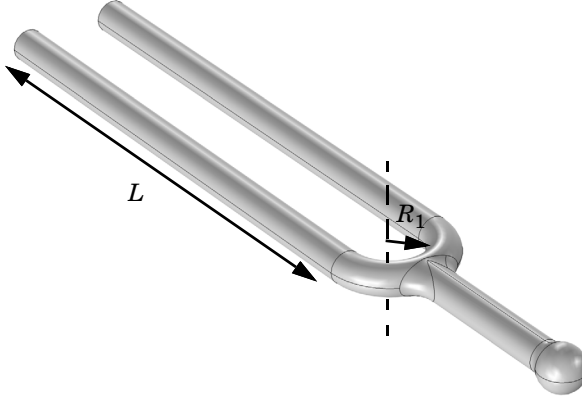

Figure 1: Tuning fork geometry.

The following formula gives a theoretical estimation for the fundamental frequency of a tuning fork with cylindrical cross section of the prong ([Ref. 1](#)):

$$f = \frac{1.875^2 R_2}{4\pi L_p^2} \sqrt{\frac{E}{\rho}} \quad (1)$$

where R_2 is the radius of the cross section of the prongs, E denotes Young's modulus, and ρ is the density. The length of the prong can be estimated as

$$L_p = L + \frac{1}{2}\pi R_1 \quad (2)$$

where R_1 the radius of the base, and L is the length of the straight cylindrical part, see [Figure 1](#).

In the fundamental eigenmode, the prongs move apart and together while the handle moves up and down as shown in [Figure 2](#). Thus, the eigenmode is symmetric with a symmetry plane placed between the prongs.

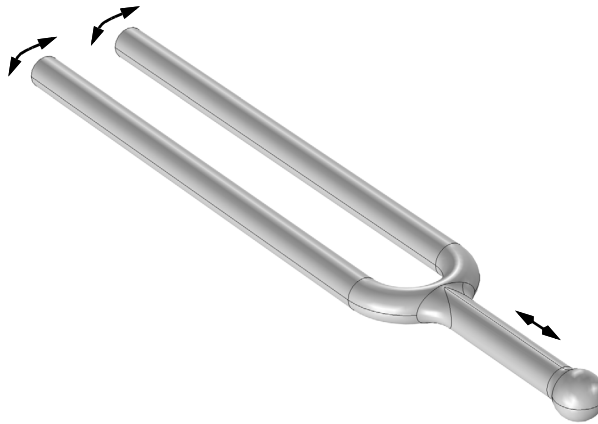

Figure 2: Vibration of the tuning fork in its fundamental eigenmode.

The advantage with the shape of the fundamental eigenmode is that the relative displacements in the handle are very small, which makes it possible to hold the fork without damping the vibration. This also allows to make use of the theoretical estimation for the frequency [Equation 1](#) which is based on the solution for a cantilever beam representing each prong.

The parameters used in the model are: $R_1 = 7.5$ mm and $R_2 = 2.5$ mm. The fork material is Steel AISI 4340, for which $E = 205$ GPa and $\rho = 7850$ kg/m³.

For the frequency $f = 440$ Hz, [Equation 1](#) and [Equation 2](#) give the length of the prong cylindrical part as $L = 7.8$ cm. This presents an underestimation because the part of the prong near the base has larger bending stiffness compared to that for a straight cantilever beam.

Results and Discussion

For the prong length of $L = 78$ mm the simulation results in an eigenfrequency of 457 Hz. This number is higher than expected, since Equation 1 and Equation 2 underestimate the prong length due to the higher stiffness at the base compared to a straight cantilever beam.

Figure 3 shows the mode shape plot for the prong length optimized for the fundamental eigenfrequency of 440 Hz. The optimized length is 79.65 mm, which, as expected, is longer than the from theory estimated 78 mm.

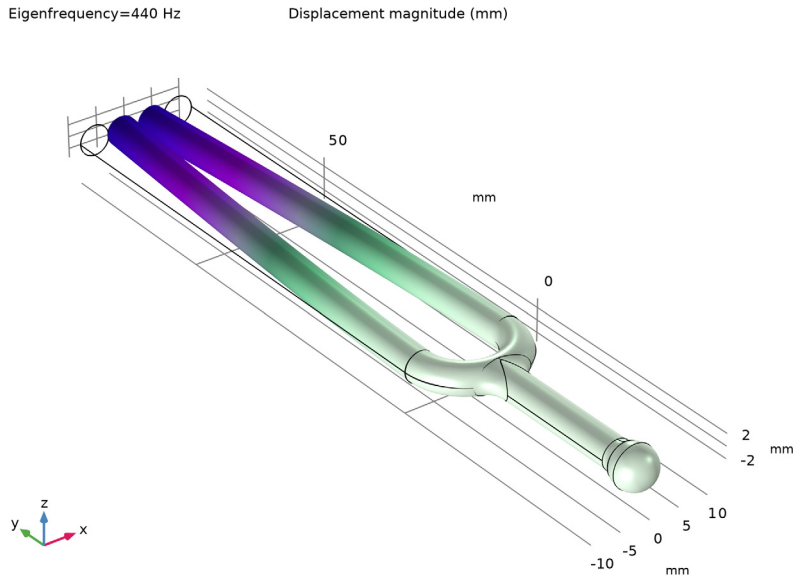

Figure 3: Frequency and mode shape of the fundamental eigenmode for the optimized tuning fork.

Notes About the COMSOL Implementation

The tuning fork geometry you are using in this model comes from an Inventor design. Using LiveLink for Inventor you synchronize the geometry and the parameter for the tuning fork prong length between Inventor and COMSOL Multiphysics. In order for this to work you need to have both programs running during modeling, and you need to make sure that the tuning fork file is the active file in Inventor.

Reference

1. *Tuning fork*, en.wikipedia.org/wiki/Tuning_fork
-

Application Library path: LiveLink_for_Inventor/Tutorials,
_LiveLink_Interface/tuning_fork_llinventor

Modeling Instructions

You can set up this simulation both by working inside Inventor, using the embedded COMSOL simulation environment, and by working in the standalone COMSOL Desktop. Regardless which way you proceed, first you need to open the CAD file with the geometry in Inventor.

- 1 In Inventor open the file `tuning_fork.ipt` located in the model's Application Library folder.
- 2 Switch to the COMSOL Desktop, and skip the next section. Or, continue below if you are working inside Inventor.

MODELING INSIDE INVENTOR

- 1 On the **COMSOL Multiphysics** tab click the **New** button.
In case it is not already running, the COMSOL modeling environment will be started, and the geometry will be synchronized automatically.
- 2 Continue with step 2 under the Model Wizard section.



COMSOL DESKTOP

From the **File** menu, choose **New**.

NEW

In the **New** window, click  **Model Wizard**.

MODEL WIZARD

- 1 In the **Model Wizard** window, click  **3D**.
- 2 In the **Select Physics** tree, select **Structural Mechanics > Solid Mechanics (solid)**.
- 3 Click **Add**.
- 4 Click  **Study**.

5 In the **Select Study** tree, select **General Studies > Eigenfrequency**.

6 Click **Done**.

GEOMETRY I

The geometry is already synchronized if you are modeling inside Inventor, and you can skip to step 4 in the section LiveLink for Inventor 1 (cad1).

Make sure that the CAD Import Module kernel is used.

1 In the **Model Builder** window, under **Component 1 (comp1)** click **Geometry 1**.

2 In the **Settings** window for **Geometry**, locate the **Advanced** section.

3 From the **Geometry representation** list, choose **CAD kernel**.

LiveLink for Inventor 1 (cad1)

1 Right-click **Component 1 (comp1) > Geometry 1** and choose **LiveLink Interfaces > LiveLink for Inventor**.

2 In the **Settings** window for **LiveLink for Inventor**, locate the **Synchronize** section.

3 Click **Synchronize**.

After a few moments the geometry of the tuning fork appears in the **Graphics** window.

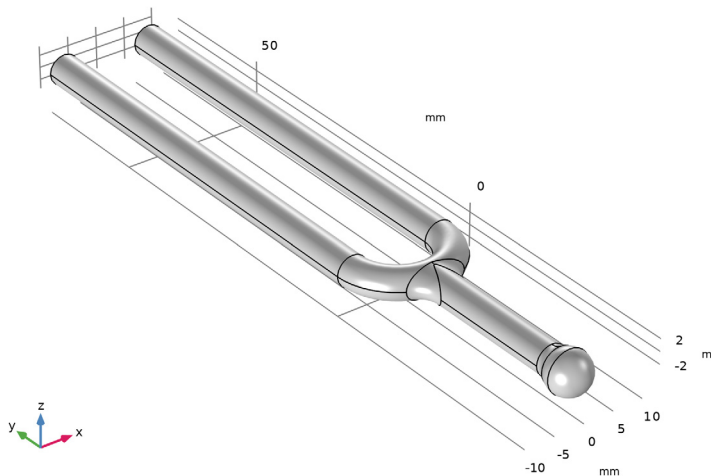

4 Click to expand the **Parameters in CAD Package** section. The dimensional parameter for the prong length, d1 in the Inventor file, has been linked to COMSOL Multiphysics and is therefore synchronized with the geometry. To manage linked parameters, you can

click **Parameter Selection** on the **COMSOL Multiphysics** tab in Inventor. The global parameter, LL_d1, is automatically generated in the COMSOL Multiphysics model during synchronization to enable parametric sweeps and optimization of the geometry.

GLOBAL DEFINITIONS

Parameters I

- 1 In the **Model Builder** window, under **Global Definitions** click **Parameters I**.
- 2 In the **Settings** window for **Parameters**, locate the **Parameters** section.
- 3 In the table, enter the following settings:

Name	Expression	Value	Description
LL_d1	78 [mm]	0.078 m	

GEOMETRY I

LiveLink for Inventor I (cad I)

- 1 In the **Model Builder** window, under **Component I (comp1) > Geometry I** click **LiveLink for Inventor I (cad I)**.
- 2 In the **Settings** window for **LiveLink for Inventor**, locate the **Synchronize** section.
- 3 Click **Synchronize** (**Update** if you are setting up the model inside Inventor).

MATERIALS

Add Material

From the **Home** menu, choose **Add Material**.

ADD MATERIAL

- 1 Go to the **Add Material** window.
- 2 In the tree, select **Built-in > Steel AISI 4340**.
- 3 Click the right end of the **Add to Component** split button in the window toolbar.
- 4 From the menu, choose **Add to Component**.
- 5 From the **Home** menu, choose **Add Material**.

STUDY I

Step 1: Eigenfrequency

Set up the study to search for the fundamental eigenfrequency.

- 1 In the **Settings** window for **Eigenfrequency**, locate the **Study Settings** section.
- 2 Select the **Desired number of eigenfrequencies** checkbox. In the associated text field, type 1.
- 3 In the **Search for eigenfrequencies around shift** text field, type 440[Hz].
- 4 In the **Model Builder** window, right-click **Study 1** and choose **Compute**.

RESULTS

Mode Shape (solid)

After the computation is finished a plot similar to the one below appears.

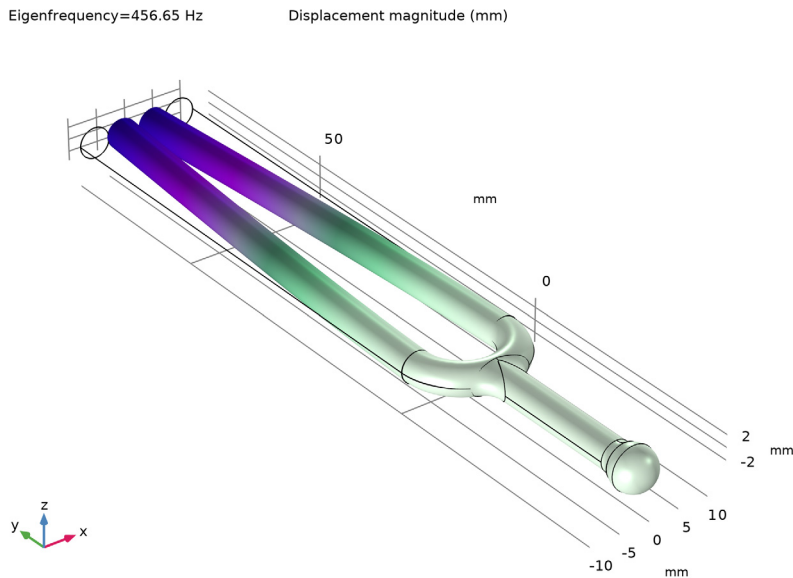

STUDY 1

Continue with setting up the optimization.

General Optimization

- 1 Right-click **Study 1** and choose **Optimization > General Optimization**.
- 2 In the **Settings** window for **General Optimization**, locate the **Optimization Solver** section.
- 3 From the **Method** list, choose **BOBYQA**.

4 Locate the **Objective Function** section. In the table, enter the following settings:

Expression	Description	Evaluate for
$(\text{freq}-440[\text{Hz}])^2$	Frequency	Eigenfrequency

5 Locate the **Control Variables and Parameters** section. Click **+ Add**.

6 In the table, enter the following settings:

Parameter	Initial value	Scale	Lower bound	Upper bound	Unit
LL_d1	78 [mm]	10 [mm]	70 [mm]	81 [mm]	m

7 Right-click **Study 1** and choose **Compute**.

RESULTS

Mode Shape (solid)

After the optimization is finished a plot similar to [Figure 3](#) is displayed. You can read the value of the eigenfrequency from the plot. Continue with displaying the value of the optimized prong length parameter in a table.

Global Evaluation 1

- 1 In the **Model Builder** window, under **Results** right-click **Derived Values** and choose **Global Evaluation**.
- 2 In the **Settings** window for **Global Evaluation**, click **Replace Expression** in the upper-right corner of the **Expressions** section. From the menu, choose **Solver > Control parameters > LL_d1 - Control parameter LL_d1 - m**.
- 3 Click **= Evaluate**.

GEOMETRY 1

LiveLink for Inventor 1 (cad1)

- 1 In the **Model Builder** window, under **Component 1 (comp1) > Geometry 1** click **LiveLink for Inventor 1 (cad1)**.
- 2 In the **Settings** window for **LiveLink for Inventor**, locate the **Parameters in CAD Package** section.
- 3 Click **Update Parameters from CAD** in the upper-right corner of the section.

Form Union (fin)

- 1 In the **Model Builder** window, click **Form Union (fin)**.

2 In the **Settings** window for **Form Union/Assembly**, click  **Build All**.