

Model created in COMSOL Multiphysics 6.4

Geometric Parameter Optimization of a Tuning Fork

Introduction

Tuning forks have traditionally been used for tuning of musical instruments due to their ability to sound a very pure tone at their fundamental eigenfrequency. To design a tuning fork that sounds the note A, 440 Hz, you first compute the fundamental eigenfrequency and eigenmode for a design with a prong length estimated from theory. Then you use geometric parameter optimization to fine tune the prong size so that the fundamental eigenfrequency corresponds to 440 Hz.

Model Definition

The model geometry is shown in [Figure 1](#). The fundamental frequency of the fork is determined by the length of the prongs, the cross-sectional geometry of the prongs, and the material properties of the fork.

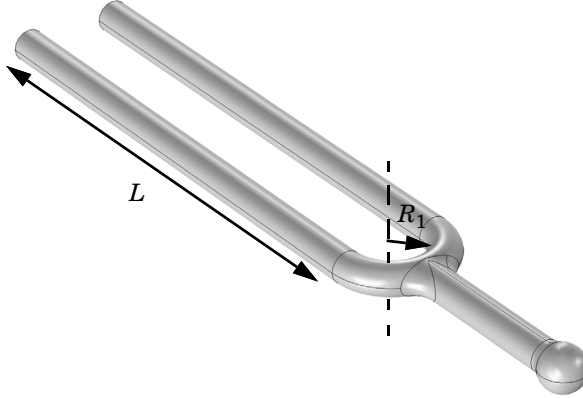

Figure 1: Tuning fork geometry.

The following formula gives a theoretical estimation for the fundamental frequency of a tuning fork with cylindrical cross section of the prong ([Ref. 1](#)):

$$f = \frac{1.875^2 R_2}{4\pi L_p^2} \sqrt{\frac{E}{\rho}} \quad (1)$$

where R_2 is the radius of the cross section of the prongs, E denotes Young's modulus, and ρ is the density. The length of the prong can be estimated as

$$L_p = L + \frac{1}{2}\pi R_1 \quad (2)$$

where R_1 the radius of the base, and L is the length of the straight cylindrical part, see [Figure 1](#).

In the fundamental eigenmode, the prongs move apart and together while the handle moves up and down as shown in [Figure 2](#). Thus, the eigenmode is symmetric with a symmetry plane placed between the prongs.

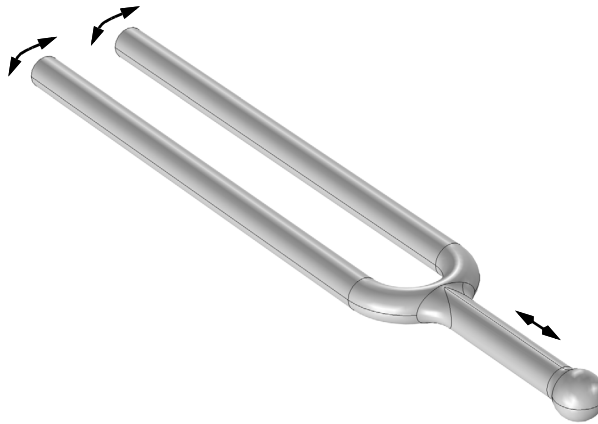

Figure 2: Vibration of the tuning fork in its fundamental eigenmode.

The advantage with the shape of the fundamental eigenmode is that the relative displacements in the handle are very small, which makes it possible to hold the fork without damping the vibration. This also allows to make use of the theoretical estimation for the frequency [Equation 1](#) which is based on the solution for a cantilever beam representing each prong.

The parameters used in the model are: $R_1 = 7.5$ mm and $R_2 = 2.5$ mm. The fork material is Steel AISI 4340, for which $E = 205$ GPa and $\rho = 7850$ kg/m³.

For the frequency $f = 440$ Hz, [Equation 1](#) and [Equation 2](#) give the length of the prong cylindrical part as $L = 7.8$ cm. This presents an underestimation because the part of the prong near the base has larger bending stiffness compared to that for a straight cantilever beam.

Reference

1. *Tuning fork*, en.wikipedia.org/wiki/Tuning_fork
-

Application Library path: LiveLink_for_PTC_Creo_Parametric/Tutorials, _LiveLink_Interface/tuning_fork_llcreop

Modeling Instructions

- 1 In PTC Creo Parametric open the file `tuning_fork.prt` located in the model's Application Library folder.
- 2 Switch to the COMSOL Desktop.



COMSOL DESKTOP

From the **File** menu, choose **New**.

NEW

In the **New** window, click  **Model Wizard**.

MODEL WIZARD

- 1 In the **Model Wizard** window, click  **3D**.
- 2 In the **Select Physics** tree, select **Structural Mechanics > Solid Mechanics (solid)**.
- 3 Click **Add**.
- 4 Click  **Study**.
- 5 In the **Select Study** tree, select **General Studies > Eigenfrequency**.
- 6 Click  **Done**.

GEOMETRY I

Make sure that the CAD Import Module kernel is used.

- 1 In the **Model Builder** window, under **Component 1 (comp1)** click **Geometry 1**.
- 2 In the **Settings** window for **Geometry**, locate the **Advanced** section.
- 3 From the **Geometry representation** list, choose **CAD kernel**.

LiveLink for PTC Creo Parametric 1 (cad1)

- 1 In the **Home** toolbar, click  **LiveLink** and choose **LiveLink for PTC Creo Parametric**.

2 In the **Settings** window for **LiveLink for PTC Creo Parametric**, locate the **Synchronize** section.

3 Click **Synchronize**.

After a few moments the geometry of the tuning fork appears in the **Graphics** window.

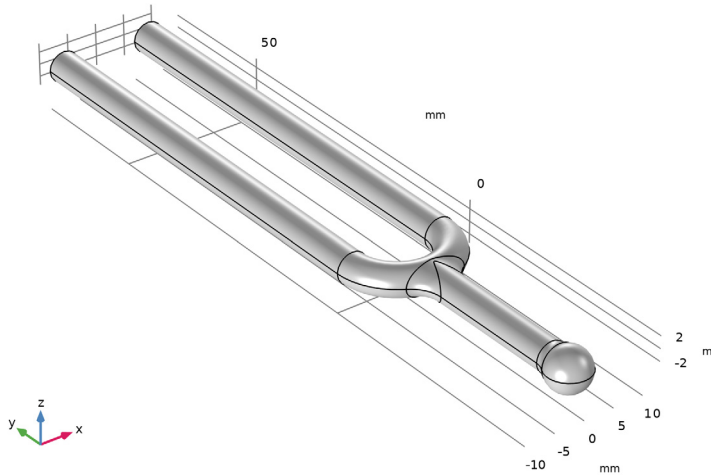

4 Click to expand the **Parameters in CAD Package** section. The dimensional parameter for the prong length, d1 in the PTC Creo Parametric file, has been linked to COMSOL Multiphysics and is therefore synchronized with the geometry. To manage linked parameters, you can click **Parameter Selection** on the **COMSOL Multiphysics** tab in PTC Creo Parametric. The global parameter, LL_d1, is automatically generated in the COMSOL Multiphysics model during synchronization to enable parametric sweeps and optimization of the geometry.

GLOBAL DEFINITIONS

Parameters 1

1 In the **Model Builder** window, under **Global Definitions** click **Parameters 1**.

2 In the **Settings** window for **Parameters**, locate the **Parameters** section.

3 In the table, enter the following settings:



Name	Expression	Value	Description
LL_d1	78 [mm]	0.078 m	

GEOMETRY I

LiveLink for PTC Creo Parametric I (cad I)

- 1 In the **Model Builder** window, under **Component I (comp I) > Geometry I** click **LiveLink for PTC Creo Parametric I (cad I)**.
- 2 In the **Settings** window for **LiveLink for PTC Creo Parametric**, locate the **Synchronize** section.
- 3 Click **Synchronize**.

ADD MATERIAL

- 1 In the **Materials** toolbar, click  **Add Material** to open the **Add Material** window.
- 2 Go to the **Add Material** window.
- 3 In the tree, select **Built-in > Steel AISI 4340**.
- 4 Click the right end of the **Add to Component** split button in the window toolbar.
- 5 From the menu, choose **Add to Component**.
- 6 In the **Materials** toolbar, click  **Add Material** to close the **Add Material** window.

STUDY I

Step 1: Eigenfrequency

Set up the study to search for the fundamental eigenfrequency.

- 1 In the **Settings** window for **Eigenfrequency**, locate the **Study Settings** section.
- 2 Select the **Desired number of eigenfrequencies** checkbox. In the associated text field, type 1.
- 3 In the **Search for eigenfrequencies around shift** text field, type 440[Hz].
- 4 In the **Study** toolbar, click  **Compute**.

RESULTS

Mode Shape (solid)

After the computation is finished a plot similar to the one below appears.

Eigenfrequency=456.61 Hz

Displacement magnitude (mm)

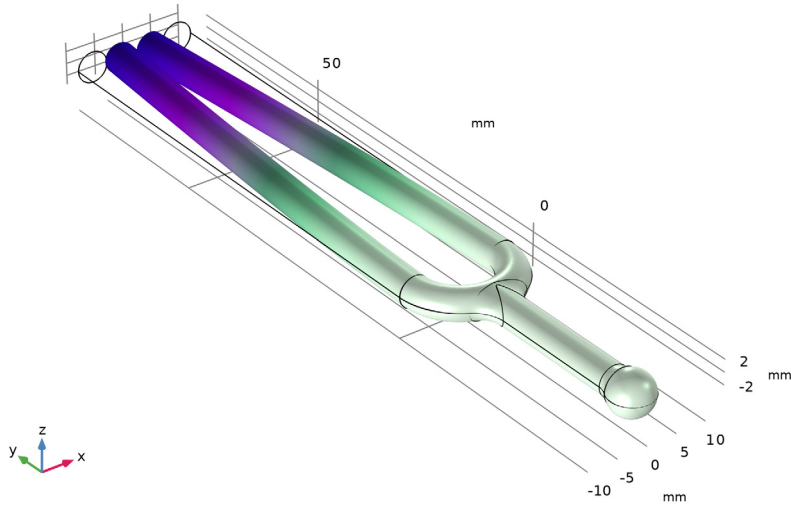

STUDY I

Continue with setting up the optimization.

General Optimization

- 1 In the **Study** toolbar, click  **Optimization** and choose **General Optimization**.
- 2 In the **Settings** window for **General Optimization**, locate the **Optimization Solver** section.
- 3 From the **Method** list, choose **BOBYQA**.
- 4 Locate the **Objective Function** section. In the table, enter the following settings:

Expression	Description	Evaluate for
$(\text{freq}-440[\text{Hz}])^2$	Frequency	Eigenfrequency

- 5 Locate the **Control Variables and Parameters** section. Click  **Add**.

6 In the table, enter the following settings:

Parameter	Initial value	Scale	Lower bound	Upper bound	Unit
LL_d1	78 [mm]	10 [mm]	70 [mm]	81 [mm]	m



7 In the **Study** toolbar, click  **Compute**.

RESULTS

Mode Shape (solid)

After the optimization is finished a plot similar to [Figure 3](#) is displayed. You can read the value of the eigenfrequency from the plot. Continue with displaying the value of the optimized prong length parameter in a table.

Global Evaluation 1

- 1 In the **Results** toolbar, click  **Global Evaluation**.
- 2 In the **Settings** window for **Global Evaluation**, click **Replace Expression** in the upper-right corner of the **Expressions** section. From the menu, choose **Solver > Control parameters > LL_d1 - Control parameter LL_d1 - m**.
- 3 Click  **Evaluate**.

GEOMETRY 1

LiveLink for PTC Creo Parametric 1 (cad1)

- 1 In the **Model Builder** window, under **Component 1 (comp1) > Geometry 1** click **LiveLink for PTC Creo Parametric 1 (cad1)**.
- 2 In the **Settings** window for **LiveLink for PTC Creo Parametric**, locate the **Parameters in CAD Package** section.
- 3 Click **Update Parameters from CAD** in the upper-right corner of the section.

Form Union (fin)

In the **Geometry** toolbar, click  **Build All**.