



Model created in COMSOL Multiphysics 6.4

Two-Pole Three-Phase Induction Motor

Introduction

Using a skewed squirrel cage in synchronous motors helps to reduce the rotor locking tendency. This locking tendency appears when the squirrel cage slots are under the stator windings, which cause magnetic attraction. Due to this nonsymmetrical design, a simulation to compute the motor torque needs to be performed either on the full motor geometry or on a 2D cross section for several angular positions of the rotor cage.

The geometry for this model is an assembly in PTC Creo Parametric. The assembly is transferred using the LiveLink interface to COMSOL Multiphysics, where the magnetic field is computed for 5 cross sections along the motor. Leveraging the selections defined with the LiveLink interface on the geometry in the PTC Creo Parametric, it is straightforward to set up the simulation.

x0(3)=0 mm freq(29)=30 Hz Surface: Magnetic flux density norm (T) Surface: 1 (1)

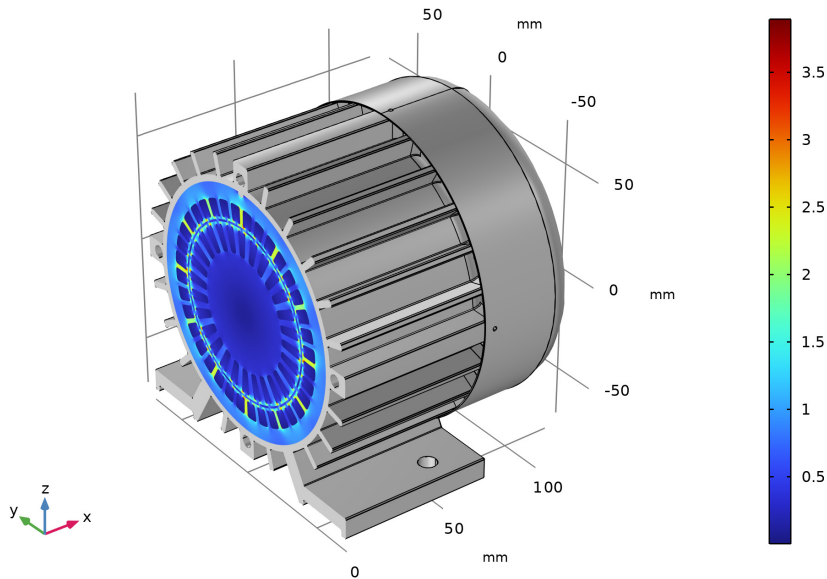

Figure 1: Plot of the magnetic flux density norm on a cross section along the motor displayed at the correct axial position on the 3D geometry.

Model Definition

The geometry of the three-phase induction motor housing is shown in [Figure 2](#) below.

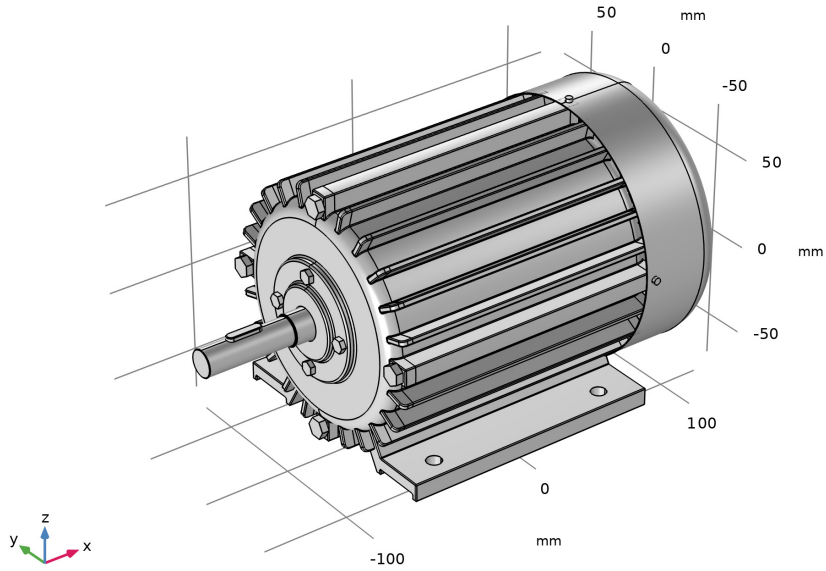

Figure 2: The geometry of a three-phase induction motor housing assembly.

The rotor consists of an iron core and an aluminum skewed squirrel cage. The cage is made of 24 bars with a tilt of 30 degrees/m.

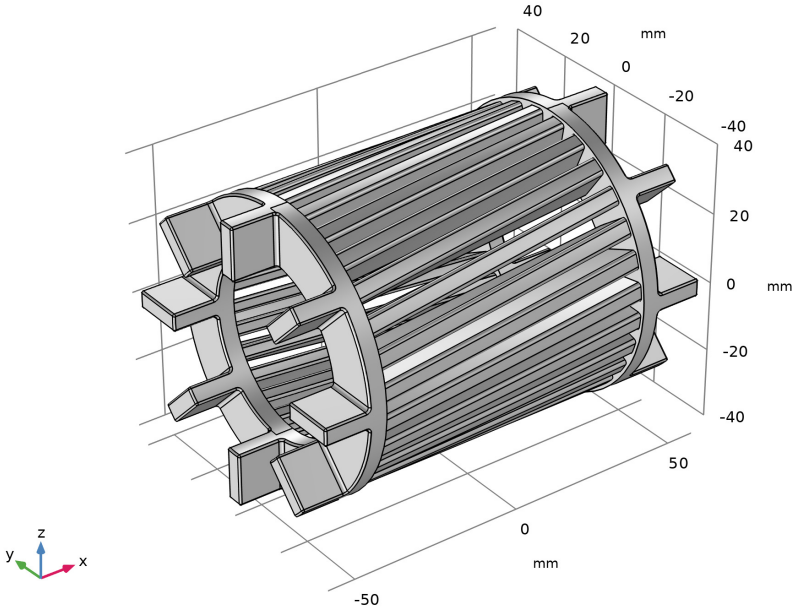

Figure 3: Skewed squirrel cage geometry of the motor.

To reduce the computational time, the simulation is solved on 2D cross sections (for example, the cross section shown in [Figure 4](#) in below).

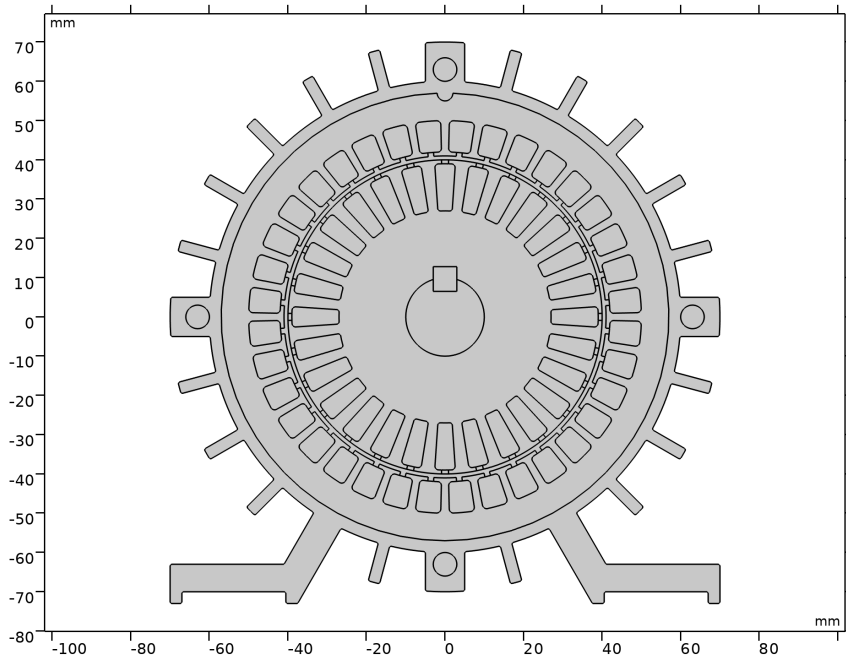

Figure 4: 2D cross section of the induction motor.

Due to the skewed shape of the squirrel cage the problem is not symmetric. Thus, you need to compute the magnetic field at several positions along the axis of the motor and then average the obtained results in order to get a better approximation. A parametric sweep is set up to automatically generate the 2D geometry and compute the solution at different positions.

The stator is made of 6 coils (single windings) with 3 slots per pole and phase, which make a total of 36 slots for a such a 2 pole pairs design. The stator core is made of soft iron and the stator coils are made of copper.

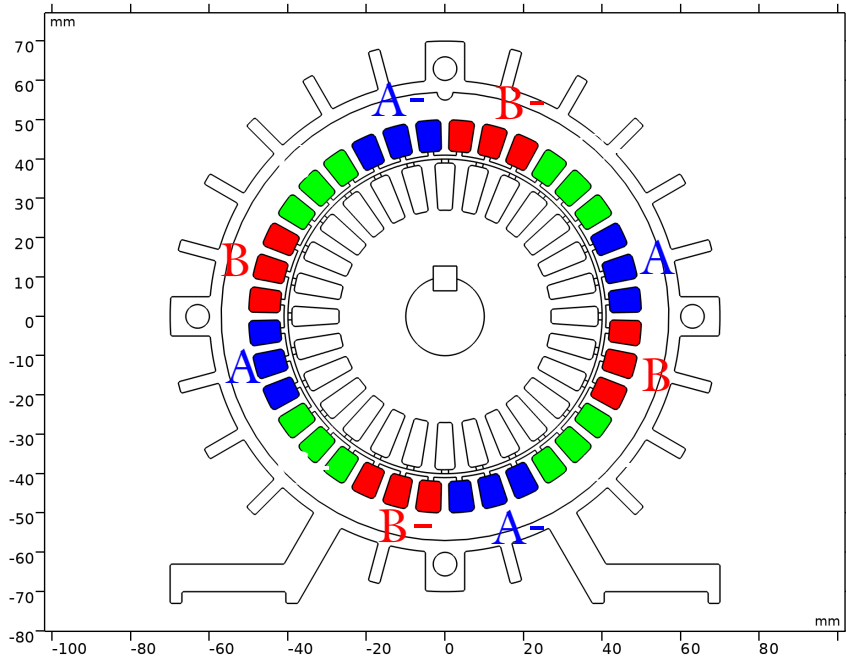

Figure 5: Windings of the 2 pairs pole three-phase induction motor.

A 0.01 A three-phase current is applied to the stator coil. The current supply frequency, f_0 , is 50 Hz. The angular speed of stator ω_s is defined as:

$$\omega_s = 2\pi \frac{f_0}{n}$$

where n is the number of pole pairs. This means that the expected angular speed of the stator is 157.08 Hz.

The slip in is defined as the ratio of the difference between the stator and rotor angular frequency relative to the stator angular frequency:

$$\text{slip} = \frac{\omega_s - \omega_r}{\omega_s}$$

When the slip is null the rotor is rotating at the same speed as the stator field. When the slip is 1 the rotor is fixed.

In this model, a time-harmonic analysis is considered to compute the motor torque, the steel losses, and the rotor losses. The implementation of a time-harmonic analysis for an induction problem is discussed in the Frequency Domain Study of Three-Phase Motor model, available in the AC/DC Module's Application Library. This model uses the approach of frozen rotor where the stator is excited at the slip angular frequency. The slip angular frequency is defined as

$$\omega_{\text{slip}} = \omega_s \cdot \text{slip}$$

The model's focus is for a slip with the range between 0% and 5%. For such a design, you can expect acceptable accuracy for a qualitative analysis.

Not all the parts of the assembly are physically modeled; only the rotor and the cage, the rotor, and the coil are considered.

Results and Discussion

Figure 6 shows the norm magnetic field together with the contour distribution of the z-component of the vector potential at 0% and 5% slip.

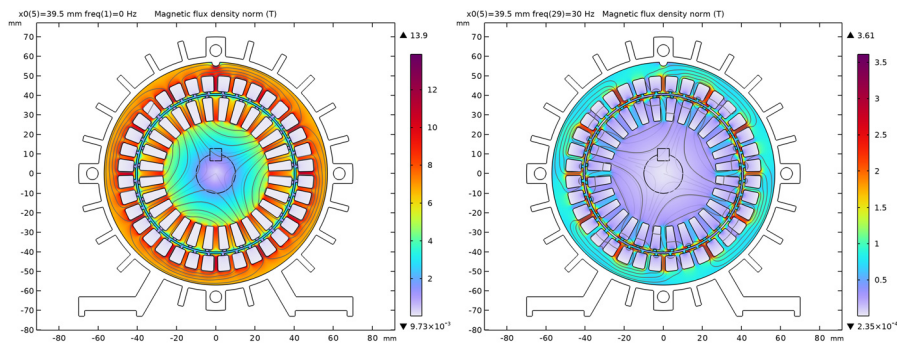

Figure 6: Norm of the magnetic field (surface) and vector potential (contour), z-component, at 0% (left) and 5% slip (right).

Figure 7 shows the out-of-plane component of the current density at 0 and 5% slip.

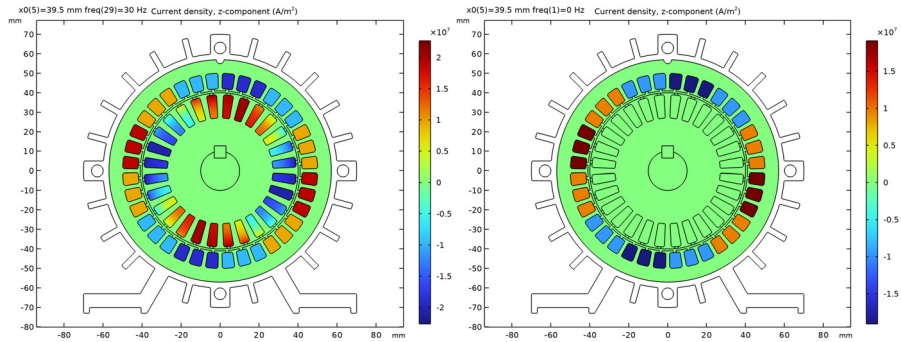

Figure 7: Current density, z-component, at 0% (left) and 5% slip (right).

Since the analysis performed is in the frequency domain, the solutions plotted in Figure 6 and Figure 7 are the real part of the norm of the magnetic field and the current density. It is possible to visualize the evolution of the fields during a cycle by changing the value of the phase in the dataset or by creating an animation using the dynamic data extension.

Figure 8 shows the torque versus the slip at several cut sections in the motor; the dashed line representing the average value. As expected for an induction motor, the torque is null at the synchronous speed. Also, a maximum is visible at a 0.3% slip. Notice the difference between the torque values depending on the cage position in the motor. The difference

can be at a maximum of 20%, which is not negligible. The average value provides a solution closer to reality.

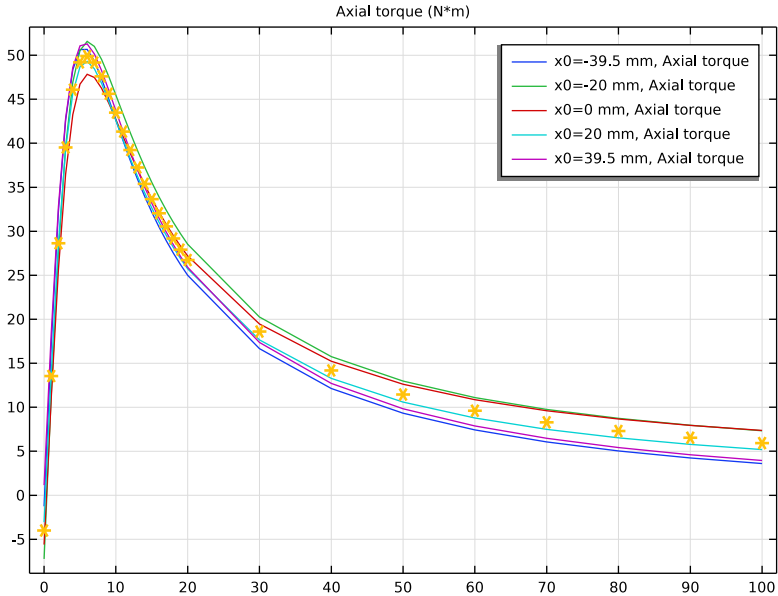

Figure 8: Torque versus slip at five different cut sections within the motor and average value (dashed).

Figure 9 shows the rotor losses versus the slip at several cut sections in the motor. As expected for an induction motor, the losses are minimal at the synchronous speed.

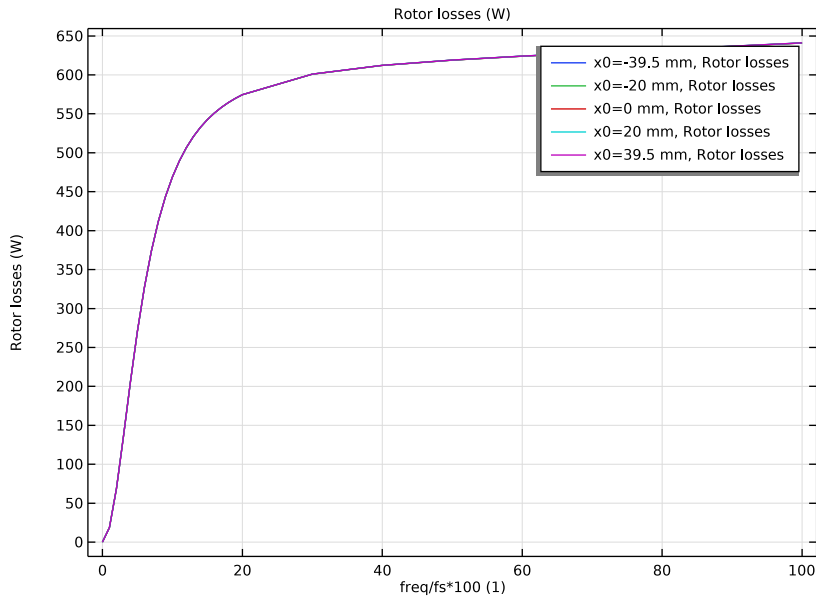

Figure 9: Rotor losses versus slip at five different cut sections within the motor.

Notes About the COMSOL Implementation

The motor assembly is transferred from PTC Creo Parametric using the LiveLink interface. For assembly components that are important for the analysis setup, selections are defined on the CAD assembly in PTC Creo Parametric using the LiveLink interface. These selections are transferred together with the geometry to COMSOL Multiphysics, and they are also mapped to the geometry of the 2D cross section, simplifying the simulation setup. The selections defined in the PTC Creo Parametric file are listed in the table below.

TABLE 1: MATERIAL SELECTIONS.

Selection name	Part name
BOLTS	M6X165_.PRT
CASING_FAN	CASING_MAIN_.PRT CASING_SIDE_.PRT CASING_LEFT_.PRT
PHASE_A	STATOR_COIL_.PRT

TABLE 1: MATERIAL SELECTIONS.

Selection name	Part name
PHASE_A_MINUS	STATOR_COIL_.PRT
PHASE_B	STATOR_COIL_2_.PRT
PHASE_B_MINUS	STATOR_COIL_2_.PRT
PHASE_C	STATOR_COIL_3_.PRT
PHASE_C_MINUS	STATOR_COIL_3_.PRT
ROTOR_COIL	ROTOR_COIL.PRT
ROTOR_CORE_SHAFT	ROTOR_CORE.prt SHAFT_.PRT KEY_80_.PRT
STATOR_CORE	STATOR_CORE_.PRT

The CAD assembly in PTC Creo Parametric is parameterized, and some key dimensional parameters have been modifiable from the simulation, so that a parametric sweep can be set up, although this currently not done in this tutorial. These parameters are listed in the table below.

TABLE 2: PARAMETERS IN CAD PACKAGE.

CAD name	COMSOL name
AIR_GAP	LL_AIR_GAP
N_BARS	LL_N_BARS
N_POLES	LL_N_POLES
N_SLOT_PER_POLE	LL_N_SLOT_PER_POLE
R_ROTOR	LL_R_ROTOR
RA_STATOR	LL_RA_STATOR
RI_CAGE	LL_RI_CAGE

For a faster update of the plot combining results from the 2D simulation with the 3D geometry, displayed in [Figure 1](#), a model method is used. The method updates the 3D representation of the geometry and the 2D solution for a specified cross-section position.

Application Library path: LiveLink_for_PTC_Creo_Parametric/Tutorials,
_LiveLink_Interface/induction_motor_llcreop

- 1 In PTC Creo Parametric open the file `induction_motor_cad/induction_motor.asm` located in the model's Application Library folder.
- 2 Switch to the COMSOL Desktop.



COMSOL DESKTOP

From the **File** menu, choose **New**.

NEW

In the **New** window, click  **Model Wizard**.

MODEL WIZARD

- 1 In the **Model Wizard** window, click  **3D**.
- 2 Click  **Done**.

GEOMETRY I

Make sure that the CAD Import Module kernel is used.

- 1 In the **Model Builder** window, under **Component 1 (comp1)** click **Geometry 1**.
- 2 In the **Settings** window for **Geometry**, locate the **Advanced** section.
- 3 From the **Geometry representation** list, choose **CAD kernel**.

LiveLink for PTC Creo Parametric 1 (cad1)

- 1 In the **Home** toolbar, click  **LiveLink** and choose **LiveLink for PTC Creo Parametric**.
- 2 In the **Settings** window for **LiveLink for PTC Creo Parametric**, locate the **Synchronize** section.
- 3 Click **Synchronize**.

GLOBAL DEFINITIONS

Parameters 1

- 1 In the **Model Builder** window, under **Global Definitions** click **Parameters 1**.
- 2 In the **Settings** window for **Parameters**, locate the **Parameters** section.

3 In the table, enter the following settings:



Name	Expression	Value	Description
x0	0	0	Section cut position
f0	60[Hz]	60 Hz	Supply frequency
a0	1[mm^2]	1E-6 m ²	Coil wire cross-section area
I_stat	5[A]	5 A	Coil wire current
fs	2*f0/LL_N_POLES	30 Hz	Synchronous frequency
L	80[mm]	0.08 m	Motor length

GEOMETRY I

Work Plane I (wp1)

- 1 In the **Geometry** toolbar, click  **Work Plane**.
- 2 In the **Settings** window for **Work Plane**, locate the **Plane Definition** section.
- 3 From the **Plane** list, choose **yz-plane**.
- 4 In the **x-coordinate** text field, type x0.

Adjacent Selection I (adjsel1)

- 1 In the **Geometry** toolbar, click  **Selections** and choose **Adjacent Selection**.
- 2 In the **Settings** window for **Adjacent Selection**, locate the **Input Entities** section.
- 3 Click  **Add**.
- 4 In the **Add** dialog, select **CASING_FAN** in the **Input selections** list.
- 5 Click **OK**.

Form Union (fin)

- 1 In the **Model Builder** window, under **Component I (comp1)** > **Geometry I** click **Form Union (fin)**.
- 2 In the **Settings** window for **Form Union/Assembly**, locate the **Form Union/Assembly** section.
- 3 From the **Action** list, choose **Form an assembly**.
- 4 Clear the **Create pairs** checkbox.

MESH I

Free Triangular I

- 1 In the **Mesh** toolbar, click  **More Generators** and choose **Free Triangular**.

- 2 In the **Settings** window for **Free Triangular**, locate the **Boundary Selection** section.
- 3 From the **Selection** list, choose **Adjacent Selection I**.
- 4 Click  **Build All**.



ADD COMPONENT

In the **Model Builder** window, right-click the root node and choose **Add Component > 2D**.

GEOMETRY 2

- 1 In the **Settings** window for **Geometry**, locate the **Units** section.
- 2 From the **Length unit** list, choose **mm**.

Cross Section 1 (crol)

- 1 In the **Geometry** toolbar, click  **Cross Section**.
- 2 In the **Settings** window for **Cross Section**, locate the **Selections of Resulting Entities** section.
- 3 Select the **Resulting objects selection** checkbox.
- 4 From the **Show in physics** list, choose **All levels**.
- 5 Select the **Selections from 3D** checkbox.
- 6 Click  **Build Selected**.

Convert to Solid 1 (csol1)

- 1 In the **Geometry** toolbar, click  **Conversions** and choose **Convert to Solid**.
- 2 In the **Settings** window for **Convert to Solid**, locate the **Input** section.
- 3 From the **Input objects** list, choose **Cross Section I**.
- 4 From the **Repair tolerance** list, choose **Relative**.
- 5 In the **Relative repair tolerance** text field, type 1.0E-5.

Force Calculation Domain

- 1 In the **Geometry** toolbar, click  **Circle**.
- 2 In the **Settings** window for **Circle**, type Force Calculation Domain in the **Label** text field.
- 3 Locate the **Size and Shape** section. In the **Radius** text field, type LL_R_ROTOR.
- 4 Locate the **Selections of Resulting Entities** section. Select the **Resulting objects selection** checkbox.

All_domains

- 1 In the **Geometry** toolbar, click  **Selections** and choose **Box Selection**.

- 2 In the **Settings** window for **Box Selection**, type All_domains in the **Label** text field.
- 3 Locate the **Resulting Selection** section. From the **Show in physics** list, choose **Off**.

Study_domains

- 1 In the **Geometry** toolbar, click  **Selections** and choose **Difference Selection**.
- 2 In the **Settings** window for **Difference Selection**, type Study_domains in the **Label** text field.
- 3 Locate the **Input Entities** section. Click the **+ Add** button for **Selections to add**.
- 4 In the **Add** dialog, select **All_domains** in the **Selections to add** list.
- 5 Click **OK**.
- 6 In the **Settings** window for **Difference Selection**, locate the **Input Entities** section.
- 7 Click the **+ Add** button for **Selections to subtract**.
- 8 In the **Add** dialog, in the **Selections to subtract** list, choose **BOLTS (Cross Section I)** and **CASING_FAN (Cross Section I)**.
- 9 Click **OK**.

Structural_steel_domains

- 1 In the **Geometry** toolbar, click  **Selections** and choose **Union Selection**.
- 2 In the **Settings** window for **Union Selection**, type Structural_steel_domains in the **Label** text field.
- 3 Locate the **Input Entities** section. Click **+ Add**.
- 4 In the **Add** dialog, in the **Selections to add** list, choose **ROTOR_CORE_SHAFT (Cross Section I)** and **STATOR_CORE (Cross Section I)**.
- 5 Click **OK**.

Form Union (fin)

- 1 In the **Model Builder** window, click **Form Union (fin)**.
- 2 In the **Settings** window for **Form Union/Assembly**, click  **Build Selected**.

ADD MATERIAL

- 1 In the **Materials** toolbar, click  **Add Material** to open the **Add Material** window.
- 2 Go to the **Add Material** window.
- 3 In the tree, select **Built-in > Air**.
- 4 Right-click and choose **Add to Global Materials**.
- 5 In the tree, select **Built-in > Aluminum**.

- 6 Right-click and choose **Add to Global Materials**.
- 7 In the tree, select **Built-in > Structural steel**.
- 8 Right-click and choose **Add to Global Materials**.
- 9 In the **Materials** toolbar, click  **Add Material** to close the **Add Material** window.

GLOBAL DEFINITIONS

Structural steel (mat3)

- 1 In the **Settings** window for **Material**, locate the **Material Contents** section.
- 2 In the table, enter the following settings:

Property	Variable	Value	Unit	Property group
Relative permeability	mur_iso ; murii = mur_iso, murij = 0	1000		Basic
Electric conductivity	sigma_iso ; sigmaii = sigma_iso, sigmaij = 0	0 [S/m]	S/m	Basic
Relative permittivity	epsilon_r_iso ; epsilon_rii = epsilon_r_iso, epsilon_rij = 0	1		Basic

MATERIALS

Material Link 1 (matLnk1)

In the **Model Builder** window, under **Component 2 (comp2)** right-click **Materials** and choose **More Materials > Material Link**.

Material Link 2 (matLnk2)

- 1 Right-click **Materials** and choose **More Materials > Material Link**.
- 2 In the **Settings** window for **Material Link**, locate the **Geometric Entity Selection** section.
- 3 From the **Selection** list, choose **ROTOR_COIL (Cross Section 1)**.
- 4 Locate the **Link Settings** section. From the **Material** list, choose **Aluminum (mat2)**.

Material Link 3 (matLnk3)

- 1 Right-click **Materials** and choose **More Materials > Material Link**.
- 2 In the **Settings** window for **Material Link**, locate the **Geometric Entity Selection** section.

- 3 From the **Selection** list, choose **Structural_steel_domains**.
- 4 Locate the **Link Settings** section. From the **Material** list, choose **Structural steel (mat3)**.

DEFINITIONS (COMP2)

Integration 1 (intop1)

- 1 In the **Definitions** toolbar, click  **Nonlocal Couplings** and choose **Integration**.
- 2 In the **Settings** window for **Integration**, locate the **Source Selection** section.
- 3 From the **Selection** list, choose **PHASE_A (Cross Section 1)**.

Variables 1



- 1 In the **Model Builder** window, right-click **Definitions** and choose **Variables**.
- 2 In the **Settings** window for **Variables**, locate the **Variables** section.
- 3 In the table, enter the following settings:

Name	Expression	Unit	Description
A_poles	intop1(1)/LL_N_POLES	m ²	Total coil area per poles

Integration 2 (intop2)

- 1 In the **Definitions** toolbar, click  **Nonlocal Couplings** and choose **Integration**.
- 2 In the **Settings** window for **Integration**, locate the **Source Selection** section.
- 3 From the **Selection** list, choose **Force Calculation Domain**.

ADD PHYSICS

- 1 In the **Home** toolbar, click  **Add Physics** to open the **Add Physics** window.
- 2 Go to the **Add Physics** window.
- 3 In the tree, select **AC/DC** > **Electromagnetic Fields** > **Magnetic Fields (mf)**.
- 4 Click the **Add to Component 2** button in the window toolbar.
- 5 In the **Home** toolbar, click  **Add Physics** to close the **Add Physics** window.

MAGNETIC FIELDS (MF)

- 1 In the **Settings** window for **Magnetic Fields**, locate the **Domain Selection** section.
- 2 From the **Selection** list, choose **Study_domains**.
- 3 Locate the **Thickness** section. In the d text field, type L.

Ampère's Law in Solids 1

- 1 In the **Physics** toolbar, click  **Domains** and choose **Ampère's Law in Solids**.

- 2 In the **Settings** window for **Ampère's Law in Solids**, locate the **Domain Selection** section.
- 3 From the **Selection** list, choose **Structural_steel_domains**.

Coil, phase A

- 1 In the **Physics** toolbar, click  **Domains** and choose **Domain Coil**.
- 2 In the **Settings** window for **Domain Coil**, type Coil, phase A in the **Label** text field.
- 3 Locate the **Domain Selection** section. From the **Selection** list, choose **PHASE_A (Cross Section I)**.
- 4 Locate the **Coil** section. In the **Coil name** text field, type A.
- 5 From the **Conductor model** list, choose **Homogenized multiturn**.
- 6 Select the **Coil group** checkbox.
- 7 Locate the **Homogenized Conductor** section. In the N text field, type $0.9 \cdot A_{\text{poles}} / a_0$.
- 8 Locate the **Coil** section. In the I_{coil} text field, type $I_{\text{stat}} \cdot \sqrt{2} \cdot \exp(j \cdot 2 \cdot \pi)$.
- 9 Locate the **Homogenized Conductor** section. From the list, choose **User defined**.
- 10 Find the **High-frequency effective loss** subsection. Clear the **Include harmonic loss** checkbox.
- 11 In the a text field, type a_0 .

Reversed Current Direction I

- 1 In the **Physics** toolbar, click  **Attributes** and choose **Reversed Current Direction**.
- 2 In the **Settings** window for **Reversed Current Direction**, locate the **Domain Selection** section.
- 3 From the **Selection** list, choose **PHASE_AMINUS (Cross Section I)**.

Coil, phase B

- 1 In the **Physics** toolbar, click  **Domains** and choose **Domain Coil**.
- 2 In the **Settings** window for **Domain Coil**, locate the **Domain Selection** section.
- 3 From the **Selection** list, choose **PHASE_B (Cross Section I)**.
- 4 In the **Label** text field, type Coil, phase B.
- 5 Locate the **Coil** section. In the **Coil name** text field, type B.
- 6 From the **Conductor model** list, choose **Homogenized multiturn**.
- 7 Select the **Coil group** checkbox.
- 8 Locate the **Homogenized Conductor** section. In the N text field, type $0.9 \cdot A_{\text{poles}} / a_0$.
- 9 Locate the **Coil** section. In the I_{coil} text field, type $I_{\text{stat}} \cdot \sqrt{2} \cdot \exp(j \cdot 2 \cdot \pi / 6)$.
- 10 Locate the **Homogenized Conductor** section. From the list, choose **User defined**.

11 Find the **High-frequency effective loss** subsection. Clear the **Include harmonic loss** checkbox.

12 In the a text field, type $a0$.

Reversed Current Direction I

1 In the **Physics** toolbar, click  **Attributes** and choose **Reversed Current Direction**.

2 In the **Settings** window for **Reversed Current Direction**, locate the **Domain Selection** section.

3 From the **Selection** list, choose **PHASE_BMINUS (Cross Section I)**.

Coil, phase C

1 In the **Physics** toolbar, click  **Domains** and choose **Domain Coil**.

2 In the **Settings** window for **Domain Coil**, type `Coil`, phase `C` in the **Label** text field.

3 Locate the **Domain Selection** section. From the **Selection** list, choose **PHASE_C (Cross Section I)**.

4 Locate the **Coil** section. In the **Coil name** text field, type `C`.

5 From the **Conductor model** list, choose **Homogenized multiturn**.

6 Select the **Coil group** checkbox.

7 Locate the **Homogenized Conductor** section. In the N text field, type $0.9 \cdot A_{\text{poles}} / a0$.

8 Locate the **Coil** section. In the I_{coil} text field, type $I_{\text{stat}} \cdot \sqrt{2} \cdot \exp(j \cdot 2 \cdot \pi / 3)$.

9 Locate the **Homogenized Conductor** section. From the list, choose **User defined**.

10 Find the **High-frequency effective loss** subsection. Clear the **Include harmonic loss** checkbox.

11 In the a text field, type $a0$.

Reversed Current Direction I

1 In the **Physics** toolbar, click  **Attributes** and choose **Reversed Current Direction**.

2 In the **Settings** window for **Reversed Current Direction**, locate the **Domain Selection** section.

3 From the **Selection** list, choose **PHASE_CMINUS (Cross Section I)**.

DEFINITIONS (COMP2)

Cylindrical System 3 (sys3)

In the **Definitions** toolbar, click  **Coordinate Systems** and choose **Cylindrical System**.

MAGNETIC FIELDS (MF)

Force Calculation 1

- 1 In the **Physics** toolbar, click  **Domains** and choose **Force Calculation**.
- 2 In the **Settings** window for **Force Calculation**, locate the **Domain Selection** section.
- 3 From the **Selection** list, choose **Force Calculation Domain**.
- 4 Locate the **Force Calculation** section. In the **Force name** text field, type rotor.

Domain Coil 4

- 1 In the **Physics** toolbar, click  **Domains** and choose **Domain Coil**.
- 2 In the **Settings** window for **Domain Coil**, locate the **Domain Selection** section.
- 3 From the **Selection** list, choose **ROTOR_COIL (Cross Section 1)**.
- 4 Locate the **Coil** section. In the I_{coil} text field, type 0[A].

MESH 2

- 1 In the **Model Builder** window, under **Component 2 (comp2)** click **Mesh 2**.
- 2 In the **Settings** window for **Mesh**, locate the **Sequence Type** section.
- 3 From the list, choose **User-controlled mesh**.

Size

- 1 In the **Model Builder** window, under **Component 2 (comp2)** > **Mesh 2** click **Size**.
- 2 In the **Settings** window for **Size**, locate the **Element Size** section.
- 3 Click the **Custom** button.
- 4 Locate the **Element Size Parameters** section. In the **Curvature factor** text field, type 0.7.

Free Triangular 1

- 1 In the **Model Builder** window, click **Free Triangular 1**.
- 2 In the **Settings** window for **Free Triangular**, locate the **Domain Selection** section.
- 3 From the **Selection** list, choose **All domains**.
- 4 Click  **Build All**.

ADD STUDY

- 1 In the **Home** toolbar, click  **Add Study** to open the **Add Study** window.
- 2 Go to the **Add Study** window.
- 3 Find the **Studies** subsection. In the **Select Study** tree, select **General Studies** > **Frequency Domain**.



- 4 Right-click and choose **Add Study**.
- 5 In the **Home** toolbar, click  **Add Study** to close the **Add Study** window.

STUDY I

Step 1: Frequency Domain

- 1 In the **Settings** window for **Frequency Domain**, locate the **Study Settings** section.
- 2 In the **Frequencies** text field, type $fs*\{\text{range}(0,1e-2,0.2) \text{ range}(0.3,1e-1,1)\}$.

Parametric Sweep

- 1 In the **Study** toolbar, click  **Parametric Sweep**.
- 2 In the **Settings** window for **Parametric Sweep**, locate the **Study Settings** section.
- 3 Click  **Add**.
- 4 In the table, enter the following settings:

Parameter name	Parameter value list	Parameter unit
x0 (Section cut position)	-39.5 -20 0 20 39.5	mm

- 5 In the **Study** toolbar, click  **Compute**.

RESULTS

Magnetic Flux Density (mf)

- 1 In the **Settings** window for **2D Plot Group**, locate the **Data** section.
- 2 From the **Parameter value (freq (Hz))** list, choose **0**.
- 3 In the **Magnetic Flux Density (mf)** toolbar, click  **Plot**.

Current density

- 1 In the **Results** toolbar, click  **2D Plot Group**.
- 2 In the **Settings** window for **2D Plot Group**, type Current density in the **Label** text field.
- 3 Locate the **Data** section. From the **Dataset** list, choose **Study I/ Parametric Solutions I (sol2)**.

Surface I

- 1 Right-click **Current density** and choose **Surface**.
- 2 In the **Settings** window for **Surface**, locate the **Expression** section.
- 3 In the **Expression** text field, type $mf.Jz$.
- 4 In the **Current density** toolbar, click  **Plot**.

Current density

- 1 In the **Model Builder** window, click **Current density**.
- 2 In the **Settings** window for **2D Plot Group**, locate the **Data** section.
- 3 From the **Parameter value (freq (Hz))** list, choose **0**.
- 4 In the **Current density** toolbar, click  **Plot**.

Rotor torque

- 1 In the **Results** toolbar, click  **ID Plot Group**.
- 2 In the **Settings** window for **ID Plot Group**, type Rotor torque in the **Label** text field.
- 3 Locate the **Data** section. From the **Dataset** list, choose **Study 1/ Parametric Solutions 1 (sol2)**.

Global I

- 1 Right-click **Rotor torque** and choose **Global**.
- 2 In the **Settings** window for **Global**, locate the **y-Axis Data** section.
- 3 In the table, enter the following settings:

Expression	Unit	Description
mf.Tax_rotor	N*m	Axial torque

- 4 Locate the **x-Axis Data** section. From the **Parameter** list, choose **Expression**.
- 5 In the **Expression** text field, type $\text{freq}/\text{fs}*100$.
- 6 In the **Rotor torque** toolbar, click  **Plot**.

Global Evaluation I

- 1 In the **Results** toolbar, click  **Global Evaluation**.
- 2 In the **Settings** window for **Global Evaluation**, locate the **Data** section.
- 3 From the **Dataset** list, choose **Study 1/Parametric Solutions 1 (sol2)**.
- 4 From the **Table columns** list, choose **Inner solutions**.
- 5 Locate the **Expressions** section. In the table, enter the following settings:

Expression	Unit	Description
mf.Tax_rotor	N*m	Axial torque
freq/fs*100	1	Slip



- 6 Locate the **Data Series Operation** section. From the **Transformation** list, choose **Average**.
- 7 Click  **Evaluate**.

Table Graph 1

- 1 In the **Model Builder** window, right-click **Rotor torque** and choose **Table Graph**.
- 2 In the **Settings** window for **Table Graph**, locate the **Data** section.
- 3 From the **Plot columns** list, choose **Manual**.
- 4 In the **Columns** list box, select **Average: Axial torque (N*m)**.
- 5 From the **x-axis data** list, choose **Average: Slip (1)**.
- 6 Locate the **Coloring and Style** section. Find the **Line style** subsection. From the **Line** list, choose **None**.
- 7 Find the **Line markers** subsection. From the **Marker** list, choose **Cycle**.
- 8 In the **Rotor torque** toolbar, click  **Plot**.

Rotor losses

- 1 In the **Results** toolbar, click  **ID Plot Group**.
- 2 In the **Settings** window for **ID Plot Group**, type Rotor losses in the **Label** text field.
- 3 Locate the **Data** section. From the **Dataset** list, choose **Study 1/ Parametric Solutions 1 (sol2)**.

Global 1

- 1 Right-click **Rotor losses** and choose **Global**.
- 2 In the **Settings** window for **Global**, locate the **y-Axis Data** section.
- 3 In the table, enter the following settings:

Expression	Unit	Description
$\text{intop2}(\text{mf}.\text{Qh}*\text{L})$	W	Rotor losses

- 4 Locate the **x-Axis Data** section. From the **Parameter** list, choose **Expression**.
- 5 In the **Expression** text field, type $\text{freq}/\text{fs}*100$.
- 6 In the **Rotor losses** toolbar, click  **Plot**.

Study 1/Solution 1 (3) (sol1)

- 1 In the **Results** toolbar, click  **More Datasets** and choose **Solution**.
- 2 In the **Settings** window for **Solution**, locate the **Solution** section.
- 3 From the **Solution** list, choose **Parametric Solutions 1 (sol2)**.

3D Plot Group 5

- 1 In the **Results** toolbar, click  **3D Plot Group**.
- 2 In the **Settings** window for **3D Plot Group**, locate the **Plot Settings** section.

3 Clear the **Plot dataset edges** checkbox.

Surface 1

- 1 Right-click **3D Plot Group 5** and choose **Surface**.
- 2 In the **Settings** window for **Surface**, click to expand the **Title** section.
- 3 From the **Title type** list, choose **None**.
- 4 Locate the **Expression** section. In the **Expression** text field, type 1.
- 5 Locate the **Coloring and Style** section. From the **Coloring** list, choose **Uniform**.
- 6 From the **Color** list, choose **Gray**.

Filter 1

- 1 Right-click **Surface 1** and choose **Filter**.
- 2 In the **Settings** window for **Filter**, locate the **Element Selection** section.
- 3 In the **Logical expression for inclusion** text field, type $X > x0$.

3D Plot Group 5

Right-click **Filter 1** and choose **Line**.

Line 1

- 1 In the **Settings** window for **Line**, click to expand the **Title** section.
- 2 From the **Title type** list, choose **None**.
- 3 Locate the **Expression** section. In the **Expression** text field, type 1.
- 4 Locate the **Coloring and Style** section. From the **Coloring** list, choose **Uniform**.
- 5 From the **Color** list, choose **Black**.

Filter 1

- 1 Right-click **Line 1** and choose **Filter**.
- 2 In the **Settings** window for **Filter**, locate the **Element Selection** section.
- 3 In the **Logical expression for inclusion** text field, type $X > x0$.

3D Plot Group 5

Right-click **Filter 1** and choose **Surface**.

Surface 2

- 1 In the **Settings** window for **Surface**, locate the **Data** section.
- 2 From the **Dataset** list, choose **Study 1/Parametric Solutions 1 (2) (sol2)**.

- 3 Click **Replace Expression** in the upper-right corner of the **Expression** section. From the menu, choose **Component 2 (comp2) > Magnetic Fields > Magnetic > mf.normB - Magnetic flux density norm - T**.

Deformation 1

- 1 Right-click **Surface 2** and choose **Deformation**.
- 2 In the **Settings** window for **Deformation**, locate the **Expression** section.
- 3 In the **x-component** text field, type $-X+x0$.
- 4 In the **y-component** text field, type $-X-Y$.
- 5 In the **z-component** text field, type Y .
- 6 Locate the **Scale** section.
- 7 Select the **Scale factor** checkbox. In the associated text field, type 1.

Surface 3

- 1 Right-click **Surface 2** and choose **Duplicate**.
- 2 In the **Settings** window for **Surface**, locate the **Expression** section.
- 3 In the **Expression** text field, type 1.
- 4 Locate the **Coloring and Style** section. From the **Coloring** list, choose **Uniform**.
- 5 From the **Color** list, choose **Gray**.

Selection 1

- 1 Right-click **Surface 3** and choose **Selection**.
- 2 In the **Settings** window for **Selection**, locate the **Selection** section.
- 3 From the **Selection** list, choose **CASING_FAN (Cross Section 1)**.
- 4 In the **3D Plot Group 5** toolbar, click  **Plot**.

In the remaining part of the modeling, you will create a **Model Method**. This method updates the last plot group based on the selected parameters.

The method editor is only available in the Windows® version of the COMSOL Desktop.

NEW METHOD

- 1 In the **Developer** toolbar, click  **New Method**.
- 2 In the **New Method** dialog, type runPlot in the **Name** text field.
- 3 Click **OK**.

APPLICATION BUILDER

runPlot

- 1 In the **Application Builder** window, under **Methods** click **runPlot**.
- 2 Copy the following code into the **runPlot** window:

```
int[] arr = {0, 1};
for (int i : arr) {
    int j = model.result("pg5").getInt("looplevel", i);
    model.result("pg5").feature("surf2").setIndex("looplevel", j, i);
    model.result("pg5").feature("surf3").setIndex("looplevel", j, i);
}
model.result("pg5").run();
zoomExtents();
```

METHODS

In the **Home** toolbar, click  **Model Builder** to switch to the main desktop.

RESULTS

3D Plot Group 5

- 1 In the **Model Builder** window, under **Results** click **3D Plot Group 5**.
- 2 In the **Settings** window for **3D Plot Group**, locate the **Data** section.
- 3 From the **Parameter value (x0 (mm))** list, choose **0**.
- 4 In the **Developer** toolbar, click  **Method Call** and choose **runPlot**.

GLOBAL DEFINITIONS

RunPlot 1

In the **Model Builder** window, under **Global Definitions** right-click **RunPlot 1** and choose **Run**.