



Model created in COMSOL Multiphysics 6.4

Electrical Heating in a Busbar

Introduction

This example analyzes a busbar designed to conduct a direct current from a transformer to an electrical device; see [Figure 1](#). The current conducted in the busbar produces heat due to the resistive losses, a phenomenon referred to as Joule heating. The Joule heating effect is described by conservation laws for electric current and energy. Once solved for, the two conservation laws give the temperature and electric field, respectively.



Figure 1: Photo of a busbar installation, and the geometry of the busbar used in this example.

The goal of your simulation is to precisely calculate how much the busbar heats up, and to study the influence of two design parameters, the width and length of the device, on the phenomenon. By conducting a parametric sweep over a range of these parameters you can determine which combinations of the width and length parameters result in a temperature increase that is less than 30° above the ambient temperature.

Model Definition

The busbar is made of copper while for the bolts, instead of the usual steel, we choose titanium assuming a highly corrosive environment. This choice of materials is important since titanium has a lower electrical conductivity than copper and is subjected to a higher current density.

All surfaces, except the bolt contact surfaces, are cooled by natural convection in the air surrounding the busbar. We can assume that the bolt cross-section boundaries do not contribute to cooling or heating of the device. The electric potential at the upper-right

vertical bolt surface is 20 mV, and that the potential at the two horizontal surfaces of the lower bolts is 0 V.

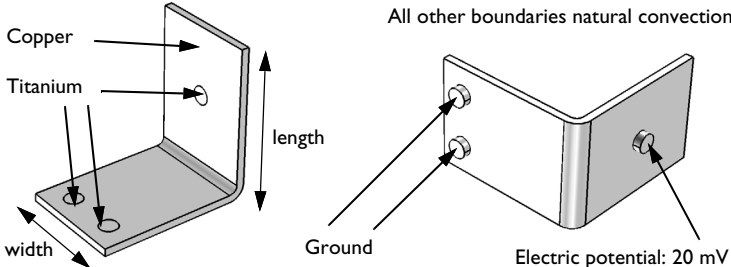

Figure 2: Material and boundary settings in the model.

Results and Discussion

The plot shown in [Figure 3](#) displays the temperature in the busbar, which is substantially higher than the ambient temperature 293 K. The temperature difference in the device is less than 10 K, due to the high thermal conductivity of copper and titanium. The

temperature variations are largest on the top bolt, which conducts double the amount of current compared to the two lower ones.

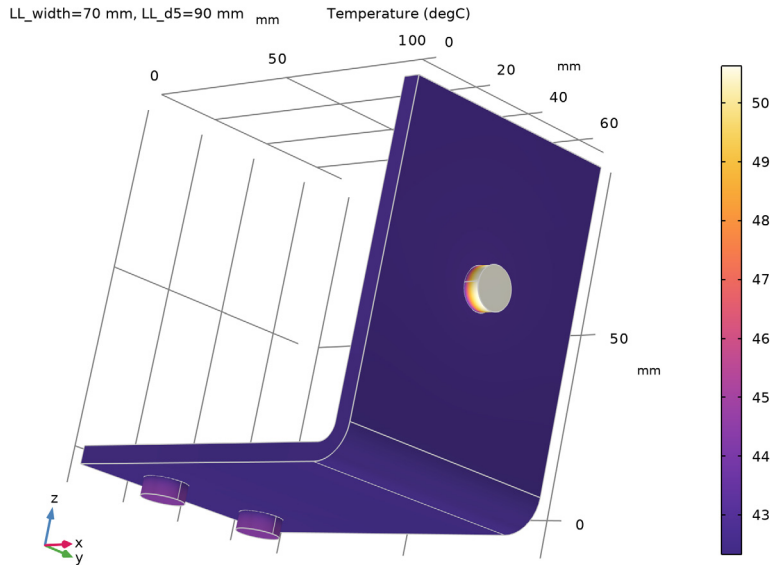

Figure 3: Temperature distribution in the busbar.

The color range of the plot in [Figure 4](#) better illustrates the low temperature variation in the copper part of the device. The temperature distribution is symmetric with a vertical mirror plane running between the two lower titanium bolts and running across the middle of the upper bolt. In this case, the model does not require much computing power and

you can model the whole geometry. For more complex models, you should consider using symmetries in order to reduce the size of the model.

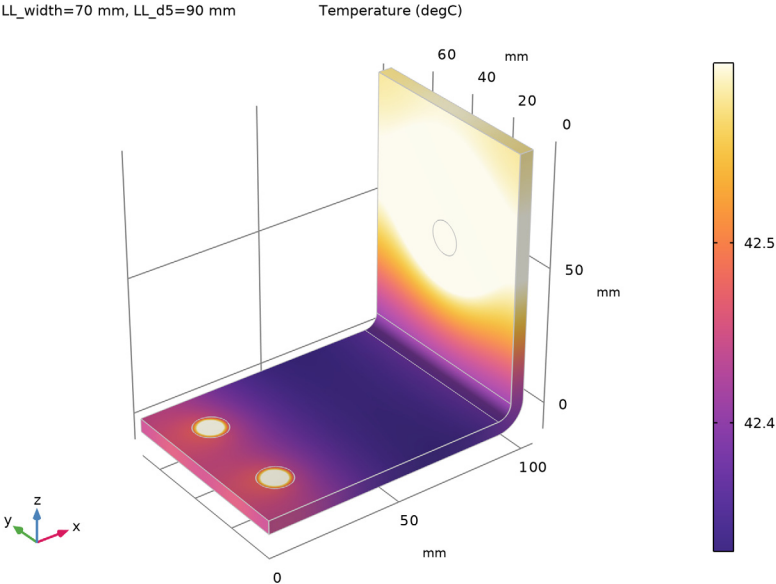

Figure 4: Temperature distribution in the copper part of the busbar.

Increasing the size of the busbar by increasing the width and length dimensions, while keeping the applied potential constant, leads to a lower temperature in the device. While the increased cross-sectional area leads to more heat produced by resistive losses, there is an even larger increase in the cooling effect as the total surface area increases, resulting in the lowering of the temperature.

By plotting the average temperature increase above the ambient temperature against the width and length parameters, and formatting the plot according to Figure 5, we can easily

determine which width and length combinations lead to an acceptable value of the temperature increase.

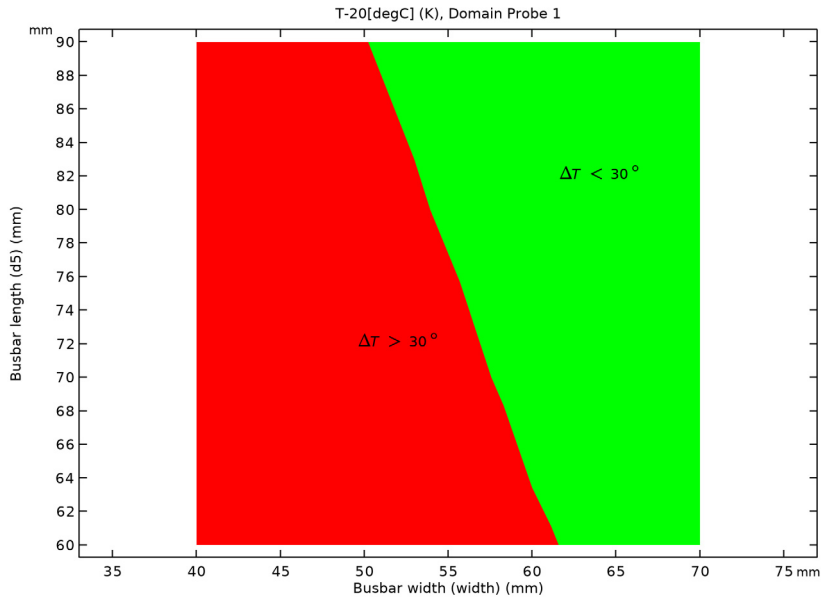

Figure 5: Average temperature increase above ambient temperature in the busbar plotted against the width and length parameters and formatted to show the parameter combinations that lead to a temperature increase of more than 30°.

Notes About the COMSOL Implementation

The busbar geometry you are using in this example comes from an AutoCAD drawing. The LiveLink interface transfers the geometry from AutoCAD to COMSOL Multiphysics. Using the interface you are also able to update the dimensions of the busbar in the AutoCAD file. In order for this to work you need to have both programs running during modeling, and you need to make sure that the busbar drawing file is the active file in AutoCAD.

Application Library path: LiveLink_for_AutoCAD/Tutorials,
_LiveLink_Interface/busbar_llac

Modeling Instructions

- 1 In AutoCAD open the file `busbar_surface.dwg` located in the model's Application Library folder.
- 2 Switch to the COMSOL Desktop.



COMSOL DESKTOP

From the **File** menu, choose **New**.

NEW

In the **New** window, click  **Model Wizard**.

MODEL WIZARD

- 1 In the **Model Wizard** window, click  **3D**.
- 2 In the **Select Physics** tree, select **Heat Transfer > Electromagnetic Heating > Joule Heating**.
- 3 Click **Add**.
- 4 Click  **Study**.
- 5 In the **Select Study** tree, select **General Studies > Stationary**.
- 6 Click  **Done**.

GEOMETRY I

Make sure that the CAD Import Module kernel is used.

- 1 In the **Model Builder** window, under **Component 1 (comp1)** click **Geometry 1**.
- 2 In the **Settings** window for **Geometry**, locate the **Advanced** section.
- 3 From the **Geometry representation** list, choose **CAD kernel**.

LiveLink for AutoCAD 1 (cad1)

- 1 In the **Home** toolbar, click  **LiveLink** and choose **LiveLink for AutoCAD**.
- 2 In the **Settings** window for **LiveLink for AutoCAD**, locate the **Synchronize** section.

3 Click **Synchronize**.

After a few moments the geometry of the busbar assembly appears in the **Graphics** window.

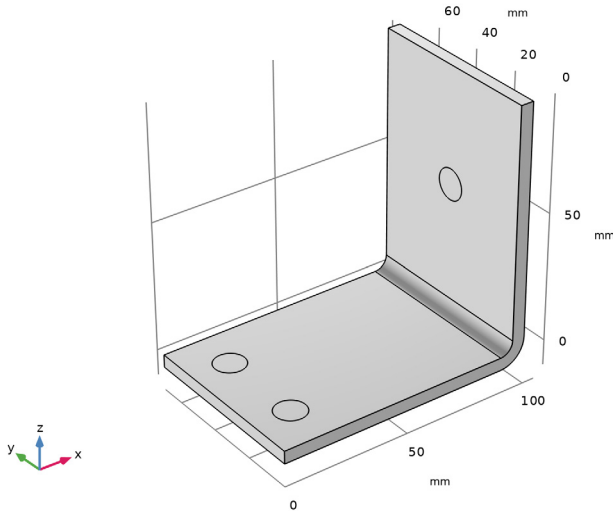

4 Click to expand the **Parameters in CAD Package** section. The table contains the two parameters, *width* and *d5*, which are part of the AutoCAD model. In AutoCAD, the **Parameter Selection** button on the **COMSOL Multiphysics** tab allows you to select and view parameters for synchronization. These parameters are retrieved, and appear in the **CAD name** column of the table. The corresponding entries in the **COMSOL name** column, *LL_width* and *LL_d5*, are global parameters in the COMSOL model. These are automatically generated during synchronization, and are assigned the values of the linked AutoCAD dimensions. The parameter values are displayed in the **COMSOL value** column.

Global parameters in a model allow you to parameterize settings and can be controlled by the parametric solver to perform parametric sweeps. Thus, by linking AutoCAD parameters to COMSOL global parameters, the parametric solver can automatically update and synchronize the geometry for each new value in a sweep.



5 Click to expand the **Object Selections** section. The selections displayed here are automatically generated based on the assigned materials in the AutoCAD file.

Knit to Solid 1 (knit1)



1 In the **Geometry** toolbar, click  **Defeaturing and Repair** and choose **Knit to Solid**.

- 2 Click in the **Graphics** window and then press Ctrl+A to select all objects.
- 3 In the **Settings** window for **Knit to Solid**, click  **Build Selected**.

Copper

- 1 In the **Geometry** toolbar, click  **Selections** and choose **Adjacent Selection**.
- 2 In the **Settings** window for **Adjacent Selection**, type Copper in the **Label** text field.
- 3 Locate the **Input Entities** section. From the **Geometric entity level** list, choose **Boundary**.
- 4 Click  **Add**.
- 5 In the **Add** dialog, select **Copper.surface** in the **Input selections** list.
- 6 Click **OK**.
- 7 In the **Settings** window for **Adjacent Selection**, locate the **Output Entities** section.
- 8 From the **Geometric entity level** list, choose **Adjacent domains**.

Titanium

- 1 In the **Geometry** toolbar, click  **Selections** and choose **Adjacent Selection**.
- 2 In the **Settings** window for **Adjacent Selection**, type Titanium in the **Label** text field.
- 3 Locate the **Input Entities** section. From the **Geometric entity level** list, choose **Boundary**.
- 4 Click  **Add**.
- 5 In the **Add** dialog, select **Titanium.surface** in the **Input selections** list.
- 6 Click **OK**.
- 7 In the **Settings** window for **Adjacent Selection**, locate the **Output Entities** section.
- 8 From the **Geometric entity level** list, choose **Adjacent domains**.

Form Union (fin)

In the **Model Builder** window, right-click **Form Union (fin)** and choose **Build Selected**.

Grounded boundaries

- 1 In the **Geometry** toolbar, click  **Selections** and choose **Explicit Selection**.
- 2 In the **Settings** window for **Explicit Selection**, type Grounded boundaries in the **Label** text field.
- 3 Locate the **Entities to Select** section. From the **Geometric entity level** list, choose **Boundary**.
- 4 On the object **fin**, select Boundaries 8 and 15 only. These are the bolt faces labeled with Ground in [Figure 2](#).

Electric potential boundary

- 1 In the **Geometry** toolbar, click  **Selections** and choose **Explicit Selection**.
- 2 In the **Settings** window for **Explicit Selection**, type **Electric potential boundary** in the **Label** text field.
- 3 Locate the **Entities to Select** section. From the **Geometric entity level** list, choose **Boundary**.
- 4 On the object **fin**, select **Boundary 31** only. This is the bolt face labeled with **Electric potential** in [Figure 2](#).

Heat flux boundaries

- 1 In the **Geometry** toolbar, click  **Selections** and choose **Difference Selection**.
- 2 In the **Settings** window for **Difference Selection**, type **Heat flux boundaries** in the **Label** text field.
- 3 Locate the **Geometric Entity Level** section. From the **Level** list, choose **Boundary**.
- 4 Locate the **Input Entities** section. Click the **+ Add** button for **Selections to add**.
- 5 In the **Add** dialog, in the **Selections to add** list, choose **Copper.surface** and **Titanium.surface**.
- 6 Click **OK**.
- 7 In the **Settings** window for **Difference Selection**, locate the **Input Entities** section.
- 8 Click the **+ Add** button for **Selections to subtract**.
- 9 In the **Add** dialog, in the **Selections to subtract** list, choose **Grounded boundaries** and **Electric potential boundary**.
- 10 Click **OK**.

GLOBAL DEFINITIONS

Parameters I

The table already contains the automatically generated global parameters that are linked to the AutoCAD parameters. It is possible to edit the values of these parameters here, and then synchronize, to modify the geometry. But here we will use the parametric solver to modify the parameters.

Continue with loading additional parameters for setting up the physics.

- 1 In the **Model Builder** window, under **Global Definitions** click **Parameters I**.
- 2 In the **Settings** window for **Parameters**, locate the **Parameters** section.
- 3 Click  **Load from File**.

- 4 Browse to the model's Application Libraries folder and double-click the file `busbar_parameters.txt`.

ADD MATERIAL

- 1 In the **Materials** toolbar, click  **Add Material** to open the **Add Material** window.
- 2 Go to the **Add Material** window.
- 3 In the tree, select **Built-in > Copper**.
- 4 Click the **Add to Component** button in the window toolbar.

MATERIALS

Copper (mat1)

- 1 In the **Settings** window for **Material**, locate the **Geometric Entity Selection** section.
- 2 From the **Selection** list, choose **Copper**.

ADD MATERIAL

- 1 Go to the **Add Material** window.
- 2 In the tree, select **Built-in > Titanium beta-21S**.
- 3 Click the **Add to Component** button in the window toolbar.
- 4 In the **Materials** toolbar, click  **Add Material** to close the **Add Material** window.

MATERIALS

Titanium beta-21S (mat2)

- 1 In the **Settings** window for **Material**, locate the **Geometric Entity Selection** section.
- 2 From the **Selection** list, choose **Titanium**.

ELECTRIC CURRENTS (EC)

Ground 1

- 1 In the **Physics** toolbar, click  **Boundaries** and choose **Ground**.
- 2 In the **Settings** window for **Ground**, locate the **Boundary Selection** section.
- 3 From the **Selection** list, choose **Grounded boundaries**.

Electric Potential 1

- 1 In the **Physics** toolbar, click  **Boundaries** and choose **Electric Potential**.
- 2 In the **Settings** window for **Electric Potential**, locate the **Boundary Selection** section.
- 3 From the **Selection** list, choose **Electric potential boundary**.

4 Locate the **Electric Potential** section. In the V_0 text field, type V_{tot} .





HEAT TRANSFER IN SOLIDS (HT)

Heat Flux I

- 1 In the **Physics** toolbar, click  **Boundaries** and choose **Heat Flux**.
- 2 In the **Settings** window for **Heat Flux**, locate the **Boundary Selection** section.
- 3 From the **Selection** list, choose **Heat flux boundaries**.
- 4 Locate the **Heat Flux** section. From the **Flux type** list, choose **Convective heat flux**.
- 5 In the h text field, type $htca$.

STUDY I

Parametric Sweep

- 1 In the **Study** toolbar, click  **Parametric Sweep**.
- 2 In the **Settings** window for **Parametric Sweep**, locate the **Study Settings** section.
- 3 Click  **Add**.
- 4 From the list in the **Parameter name** column, choose **LL_width**.
- 5 Click  **Range**.
- 6 In the **Range** dialog, type 40[mm] in the **Start** text field.
- 7 In the **Step** text field, type 10[mm].
- 8 In the **Stop** text field, type 70[mm].
- 9 Click **Replace**.
- 10 In the **Parameter unit** column, enter mm.
- 11 In the **Settings** window for **Parametric Sweep**, locate the **Study Settings** section.
- 12 Click  **Add**.
- 13 Click to select row number 2 in the table.
- 14 From the list in the **Parameter name** column, choose **LL_d5**.
- 15 Click  **Range**.
- 16 In the **Range** dialog, type 60[mm] in the **Start** text field.
- 17 In the **Step** text field, type 10[mm].
- 18 In the **Stop** text field, type 90[mm].
- 19 Click **Replace**.

20 In the **Parameter unit** column, enter mm.

As the last step before computing the solution, configure the sweep to include all combinations of the two parameters.

21 In the **Settings** window for **Parametric Sweep**, locate the **Study Settings** section.

22 From the **Sweep type** list, choose **All combinations**.

23 In the **Study** toolbar, click  **Compute**.

RESULTS

Temperature (ht)

1 In the **Model Builder** window, click **Temperature (ht)**.

2 In the **Settings** window for **3D Plot Group**, locate the **Plot Settings** section.

3 From the **Color** list, choose **Gray**.

Volume 1

1 In the **Model Builder** window, expand the **Temperature (ht)** node, then click **Volume 1**.

2 In the **Settings** window for **Volume**, locate the **Expression** section.

3 In the **Unit** field, type degC.

4 Locate the **Coloring and Style** section. From the **Color table** list, choose **HeatCameraLight**.

5 In the **Temperature (ht)** toolbar, click  **Plot**.

6 Rotate the plot in the **Graphics** window to get a view similar to the plot displayed in [Figure 3](#).

7 Click to expand the **Range** section. Select the **Manual color range** checkbox.

8 In the **Maximum** text field, type 42.6.

9 In the **Temperature (ht)** toolbar, click  **Plot**.

10 Click the  **Go to Default View** button in the **Graphics** toolbar.

You should now see a plot similar to the one in [Figure 4](#).

DEFINITIONS

Add a domain probe to calculate the average temperature increase from ambient temperature in the device.

Domain Probe 1 (dom1)

1 In the **Definitions** toolbar, click  **Probes** and choose **Domain Probe**.

2 In the **Settings** window for **Domain Probe**, locate the **Expression** section.

3 In the **Expression** text field, type T-20[degC].

4 Click  **Update Results.**

PROBE TABLE I

- 1 Go to the **Probe Table I** window.
- 2 Click the **Table Surface** button in the window toolbar.
A plot similar to the one displayed below appears.

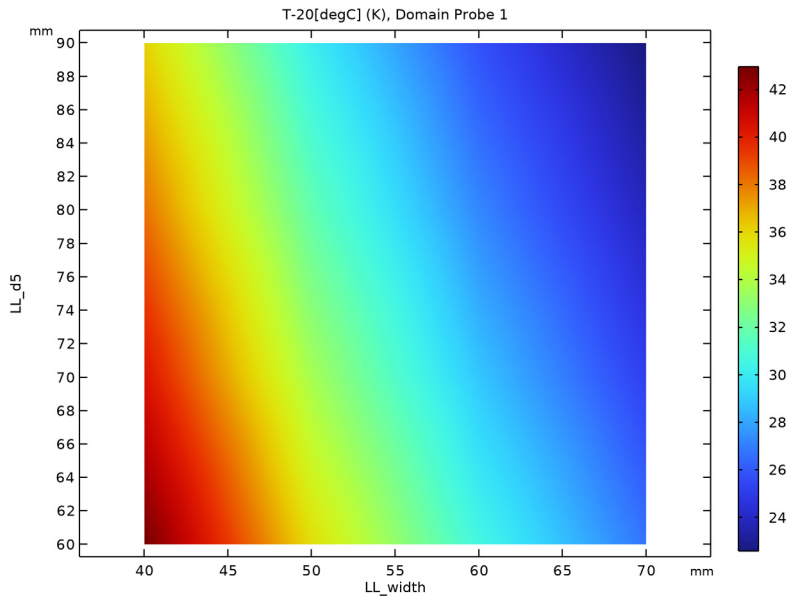

RESULTS

In the last few steps you can add annotations and format the plot to make it easier to read which parameter combinations result in an accepted temperature increase.

Table Surface 2

- 1 Right-click **Results > 2D Plot Group 5 > Table Surface 1** and choose **Duplicate**.
- 2 In the **Settings** window for **Table Surface**, click to expand the **Title** section.
- 3 From the **Title type** list, choose **None**.
- 4 Click to expand the **Range** section. Select the **Manual data range** checkbox.
- 5 In the **Maximum** text field, type 30.
- 6 Locate the **Coloring and Style** section. From the **Coloring** list, choose **Uniform**.
- 7 From the **Color** list, choose **Green**.

Table Surface 1

- 1 In the **Model Builder** window, click **Table Surface 1**.
- 2 In the **Settings** window for **Table Surface**, locate the **Range** section.
- 3 Select the **Manual data range** checkbox.
- 4 In the **Minimum** text field, type 30.
- 5 Locate the **Coloring and Style** section. From the **Coloring** list, choose **Uniform**.

2D Plot Group 5

- 1 In the **Model Builder** window, click **2D Plot Group 5**.
- 2 In the **Settings** window for **2D Plot Group**, locate the **Plot Settings** section.
- 3 Select the **x-axis label** checkbox. In the associated text field, type Busbar width (width) (mm).
- 4 Select the **y-axis label** checkbox. In the associated text field, type Busbar length (d5) (mm).

Annotation 1

- 1 Right-click **2D Plot Group 5** and choose **Annotation**.
- 2 In the **Settings** window for **Annotation**, locate the **Data** section.
- 3 From the **Dataset** list, choose **Domain Probe 1**.
- 4 Locate the **Annotation** section. In the **Text** text field, type $\Delta T > 30$ $^{\circ}$.
- 5 Locate the **Position** section. In the **x** text field, type 49[mm].
- 6 In the **y** text field, type 73[mm].
- 7 Locate the **Annotation** section. Select the **LaTeX markup** checkbox.
- 8 Locate the **Coloring and Style** section. Clear the **Show point** checkbox.

Annotation 2

- 1 Right-click **2D Plot Group 5** and choose **Annotation**.
- 2 In the **Settings** window for **Annotation**, locate the **Data** section.
- 3 From the **Dataset** list, choose **Domain Probe 1**.
- 4 Locate the **Annotation** section. In the **Text** text field, type $\Delta T < 30$ $^{\circ}$.
- 5 Locate the **Position** section. In the **x** text field, type 61[mm].
- 6 In the **y** text field, type 83[mm].
- 7 Locate the **Annotation** section. Select the **LaTeX markup** checkbox.

8 Locate the **Coloring and Style** section. Clear the **Show point** checkbox.

9 In the **2D Plot Group 5** toolbar, click  **Plot**.

The plot in the **Graphics** window should now look similar to the one in [Figure 5](#).