



Model created in COMSOL Multiphysics 6.4

Thermal Performances of Windows

Introduction

During the design of a building, environmental issues have gained considerable influence in the entire project. One of the first concerns is to improve thermal performances. In this process, simulation softwares provide key tools for modeling thermal losses and performances in the building.

The international standard ISO 10077-2:2012 (Ref. 1) deals with thermal performances of windows, doors, and shutters. It provides computed values of the thermal characteristics of frame profiles in order to validate a simulation software.

COMSOL Multiphysics successfully passes the entire benchmark. This document describes six frame profiles of ISO 10077-2:2012 related to windows only. Other test cases from this standard are available in the following applications:

- [Thermal Performances of Roller Shutters](#)
- [Glazing Influence on Thermal Performances of a Window](#)

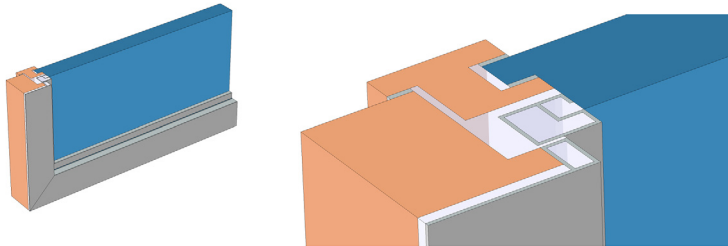

Figure 1: Geometry of one of the windows and cross-section view.

Model Definition

On each test case, a window section separates a hot internal side from a cold external side. In these applications, the traditional glazing is replaced by an insulation panel. After solving a model, two quantities are calculated and compared to the normative values:

- The thermal conductance between the internal and external sides
- The thermal transmittance of the window frame

AIR CAVITIES

A window frame contains many cavities. The purpose is to ensure thermal insulation. According to the standard, cavities are modeled in different ways, depending on their

shapes and on the width of the slit connecting them to the interior or exterior environment. Cavities are divided into three types:

- *unventilated cavities*, completely closed or connected either to the exterior or to the interior by a slit with a width not exceeding 2 mm
- *slightly ventilated cavities*, connected either to the exterior or to the interior by a slit greater than 2 mm but not exceeding 10 mm
- *well-ventilated cavities*, corresponding to a configuration not covered by one of the two preceding types

In unventilated and slightly ventilated cavities, the heat flow rate is represented by an equivalent thermal conductivity k_{eq} , which includes the heat flow by conduction, convection, and radiation, and depends on the geometry of the cavity and on the adjacent materials. See [Unventilated Rectangular Cavity](#), [Slightly Ventilated Rectangular Cavities](#), and [Nonrectangular Cavities](#) for the definition of k_{eq} . These cavities are explicitly represented as domains in the geometry.

In well-ventilated cavities, it is assumed that the whole surface of the cavity is exposed to the interior or exterior environment. Therefore, the interior of these cavities is not explicitly represented as a domain, and convective heat flux boundary conditions are applied instead to the surface of the cavity (see the [Boundary conditions](#) section below for more information). See [Figure 8](#) for an example configuration containing such a cavity connected to the exterior.

Unventilated Rectangular Cavity

For an unventilated rectangular cavity, the equivalent thermal conductivity is defined by

$$k_{eq} = \frac{d}{R}$$

where d is the cavity dimension in the heat flow rate direction, and R is the cavity thermal resistance given by

$$R = \frac{1}{h_a + h_r}$$

where h_a is the convective heat transfer coefficient, and h_r is the radiative heat transfer coefficient. These coefficients are defined by

$$h_a = \begin{cases} \frac{C_1}{d} & \text{if } b \leq 5 \text{ mm} \\ \max\left(\frac{C_1}{d}, C_2 \Delta T^{1/3}\right) & \text{otherwise} \end{cases}$$

$$h_r = 4\sigma T_m^3 EF$$

where

- $C_1 = 0.025 \text{ W}/(\text{m}\cdot\text{K})$
- $C_2 = 0.73 \text{ W}/(\text{m}^2\cdot\text{K}^{4/3})$
- ΔT is the maximum surface temperature difference in the cavity
- $\sigma = 5.67\cdot 10^{-8} \text{ W}/(\text{m}^2\cdot\text{K}^4)$ is the Stefan–Boltzmann constant
- T_m is the average temperature on the boundaries of the cavity
- E is the intersurface emittance, defined by

$$E = \frac{1}{\frac{1}{\varepsilon_1} + \frac{1}{\varepsilon_2} - 1}$$

- ε_1 and ε_2 are the surface emissivities (both are equal to 0.90 in this model)
- F is the view factor of the rectangular section, defined by

$$F = \frac{1}{2} \left(1 - \frac{d}{b} + \sqrt{1 + \left(\frac{d}{b}\right)^2} \right)$$

- d is the cavity dimension in the heat flow rate direction
- b is the cavity dimension perpendicular to the heat flow rate direction

Slightly Ventilated Rectangular Cavities

For a slightly ventilated cavity, the equivalent thermal conductivity is twice that of an unventilated cavity of the same size.

Nonrectangular Cavities

Nonrectangular cavities are transformed into rectangular cavities of same area and aspect ratio according to defined rules in ISO 10077-2:2012 presented below. Then, k_{eq} is evaluated following one of the two previous rectangular cases.

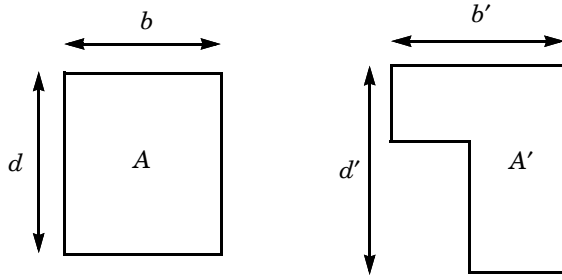

Figure 2: Nonrectangular cavity transformation.

Figure 2 shows a nonrectangular cavity of area A' . Then, d' and b' are the depth and the width (in accordance with the direction of the heat flow) of the smallest rectangle than can contain of the nonrectangular cavity. The equivalent rectangular cavity, of size $b \times d$ and area A must satisfy

$$A = A' \quad \frac{d}{b} = \frac{d'}{b'}$$

Hence, b and d are given by

$$b = \sqrt{A' \frac{b'}{d'}} \quad d = \sqrt{A' \frac{d'}{b'}}$$

BOUNDARY CONDITIONS

The heat flux conditions for internal and external sides are given by Newton's law of cooling:

$$-\mathbf{n} \cdot (-k\nabla T) = h(T_{\text{ext}} - T)$$

where T_{ext} is the exterior temperature ($T_{\text{ext}} = T_i = 20^\circ\text{C}$ for the internal side and $T_{\text{ext}} = T_e = 0^\circ\text{C}$ for the external side). The standard defines thermal surface resistance, R_s , which is related to the heat transfer coefficient, h , by

$$h = \frac{1}{R_s}$$

Internal and external thermal surface resistances are not equal. Moreover, on boundaries linked to the internal side, an increased thermal resistance is used in edges. [Figure 3](#) explains how to determine boundaries where it should be applied.

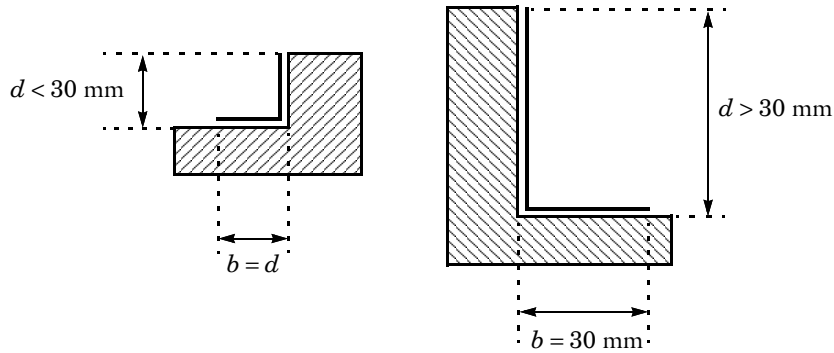

Figure 3: Protected boundaries.

If d is greater than 30 mm, b is set to 30 mm. Otherwise, $b = d$ is chosen. Furthermore, two boundaries are considered as adiabatic: the boundary in contact with the wall and the end of the insulation panel.

DESCRIPTION OF THE SIX APPLICATIONS

[Figure 4](#) to [Figure 9](#) depict the geometry of each application but only a part of the insulation panel is represented. Unventilated cavities are red-numbered while slightly ventilated cavities are green-numbered. Boundaries with an increased thermal resistance are represented with bold black lines. Adiabatic boundaries in contact with the wall are represented with a striped rectangle.

Application 1: Aluminum Frame with Thermal Break

The first application studies the heat conduction in an aluminum frame section with thermal break. The frame structure is made of aluminum with a high thermal conductivity k of $160 \text{ W}/(\text{m}\cdot\text{K})$. Four barriers made of polyamide 6.6 with 25% of glass fiber compose the thermal break. They have a low thermal conductivity of $0.30 \text{ W}/(\text{m}\cdot\text{K})$. Ethylene propylene diene monomer (EPDM) rubber gaskets are also used to waterproof the window. EPDM rubber has a thermal conductivity of $0.25 \text{ W}/(\text{m}\cdot\text{K})$. The insulation panel has a very low thermal conductivity of $0.035 \text{ W}/(\text{m}\cdot\text{K})$.

This frame is divided into many cavities: most of them (red-numbered from 1 to 9 on [Figure 4](#)) are considered as *unventilated cavities* because they are not connected to the exterior. One cavity is connected to the exterior. According to the standard, this cavity is cut into two “subcavities” due to its internal 2 mm width slit. The first cavity (red-

numbered 10 on Figure 4) is considered as *unventilated cavity* and the second cavity (green-numbered 1 on Figure 4) is considered as a *slightly ventilated cavity*.

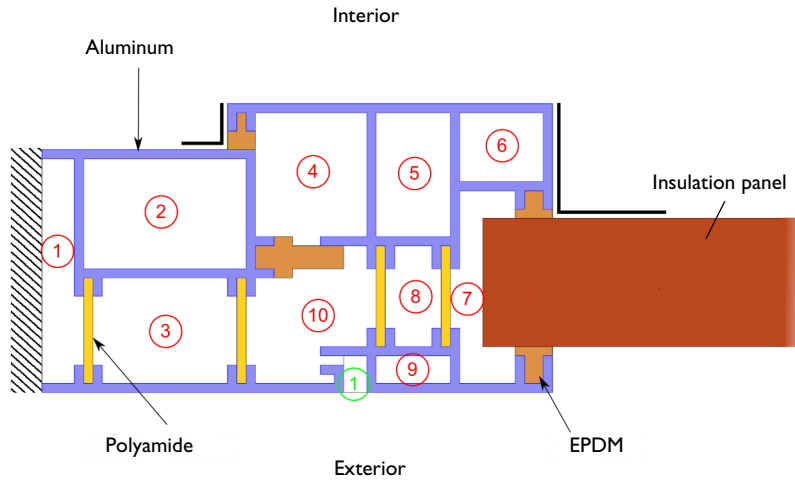

Figure 4: Geometry of the first window.

Application 2: Aluminum Clad Wood Frame

The second application studies the heat conduction in an aluminum clad wood frame section. The frame is made of two wood blocks with a thermal conductivity of $0.13 \text{ W}/(\text{m}\cdot\text{K})$. On the external side, a wood block is covered by an aluminum structure which has a high thermal conductivity. This application includes EPDM gaskets too.

All cavities are considered as *unventilated cavities* because they are either closed or connected to the exterior by a 2 mm width slit.

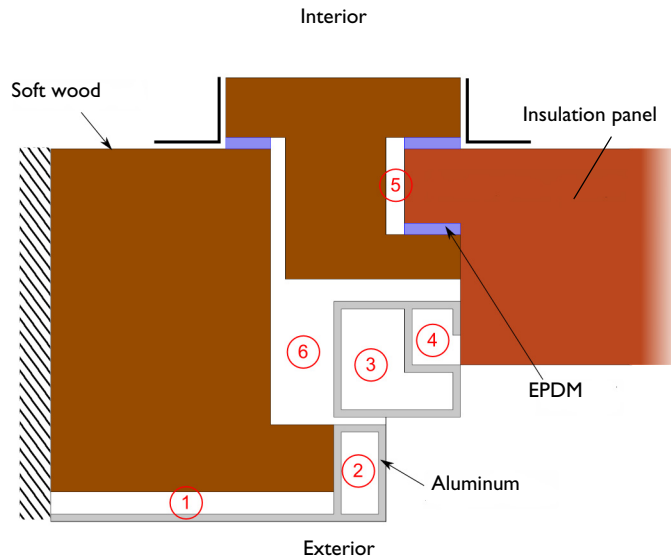

Figure 5: Geometry of the second window.

Application 3: PVC Frame with Steel Reinforcement

The third application studies the heat conduction in a PVC frame section with steel reinforcement. The main structure of the frame is made of PVC, which has a thermal conductivity of $0.17 \text{ W}/(\text{m}\cdot\text{K})$. Two reinforcements made of steel are also present. Steel has a high thermal conductivity of $50 \text{ W}/(\text{m}\cdot\text{K})$. EPDM gaskets are used.

Air cavities are all completely closed or connected to the exterior by a slit with a width not exceeding 2 mm. Thus they are considered as *unventilated cavities*.

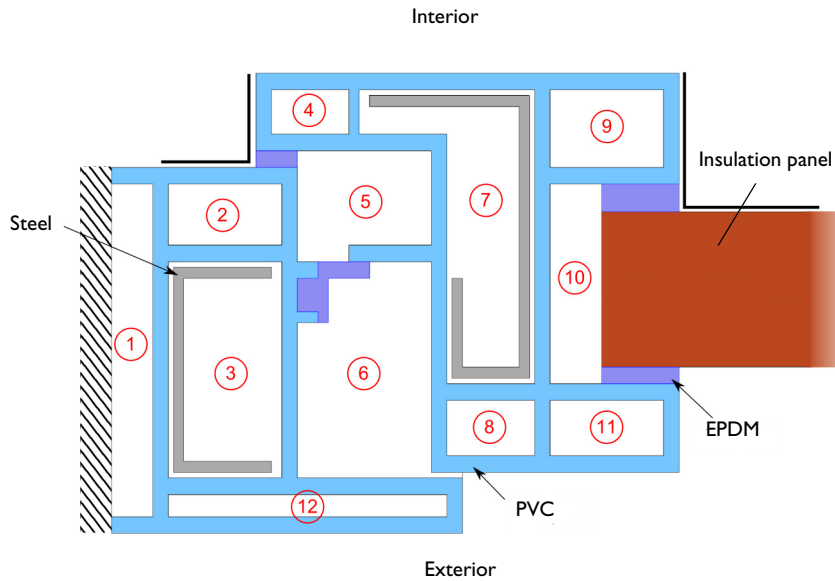

Figure 6: Geometry of the third window.

Application 4: Roof Window

The fourth application studies the heat conduction in a roof window frame section. The main part of the frame is made of two soft wood blocks. The interior part is aluminum clad and there are also EPDM gaskets.

Three air cavities are not connected to the exterior or only by a slit with a width smaller than 2 mm. They are considered as *unventilated*. Four others air cavities are considered as *slightly ventilated cavities*.

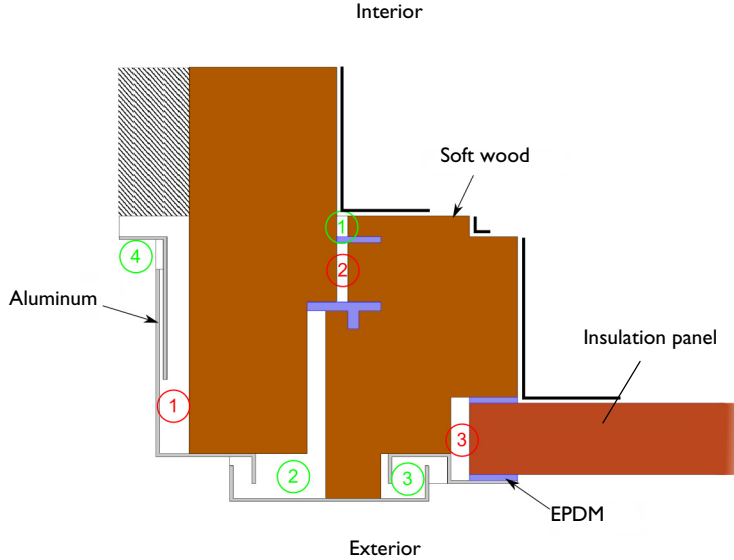

Figure 7: Geometry of the fourth window.

Application 5: Sliding Window

The fifth application studies the heat conduction in a sliding window frame section. The frame has an aluminum structure with a high thermal conductivity. There are some thermal breaks made of rigid polyurethane (PU), polyamide, and polyester mohair. Their thermal conductivities are $0.25 \text{ W}/(\text{m}\cdot\text{K})$, $0.25 \text{ W}/(\text{m}\cdot\text{K})$, and $0.14 \text{ W}/(\text{m}\cdot\text{K})$, respectively. There are also some EPDM gaskets to waterproof the window.

Four air cavities are completely closed, and two others are connected to the exterior by a 2 mm width slit. According to the standard, they are considered as *unventilated cavities*. One cavity is considered as a *slightly ventilated cavity* because it is connected to the exterior by a larger slit of 6 mm. In addition, one last cavity is considered as *well ventilated* because it is connected to the exterior with a 15 mm width slit.

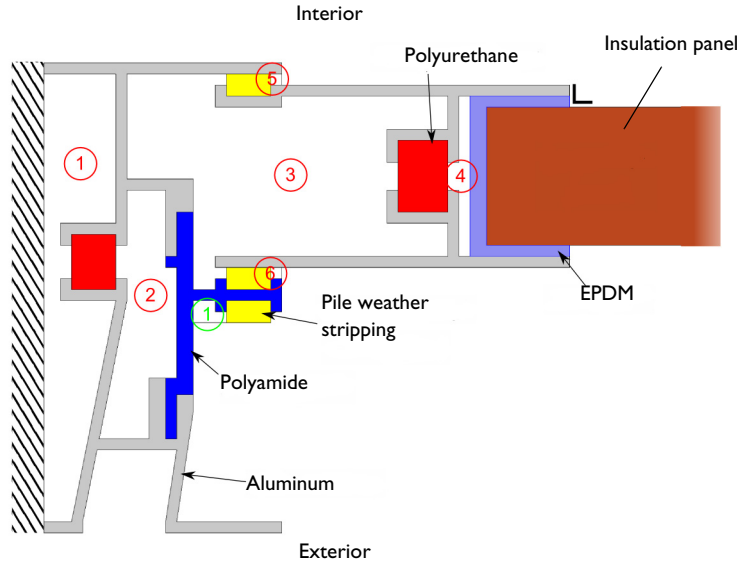

Figure 8: Geometry of the fifth window.

Application 6: PVC Frame

The sixth application studies the heat conduction in a fixed PVC frame section. Polyamide with a thermal conductivity of $0.25 \text{ W}/(\text{m}\cdot\text{K})$ is used. There are also some EPDM gaskets to waterproof the window.

In this application, there are seven closed cavities. They are considered as *unventilated*. In addition, one cavity is connected to the exterior by a 3 mm width slit so it is considered as *slightly ventilated*.

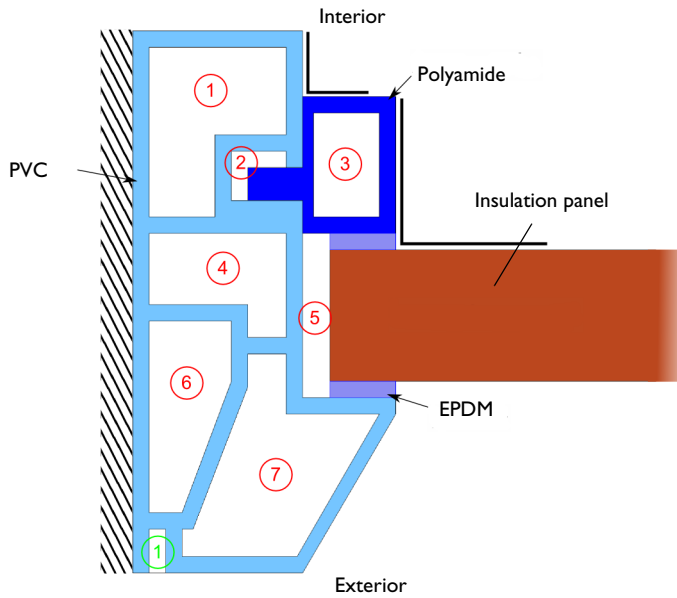

Figure 9: Geometry of the sixth window.

Results and Discussion

TEMPERATURE PROFILES

The temperature profiles for each application are shown in [Figure 10](#) through [Figure 15](#).

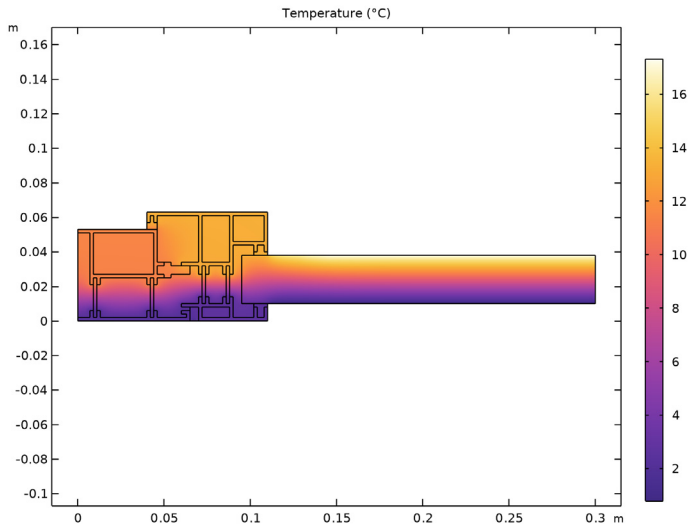

Figure 10: Temperature distribution in the aluminum frame with thermal break.

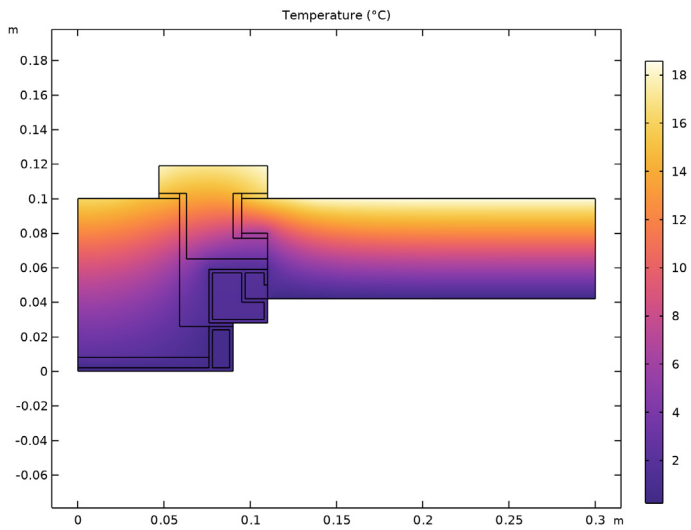

Figure 11: Temperature distribution in the aluminum clad wood frame.

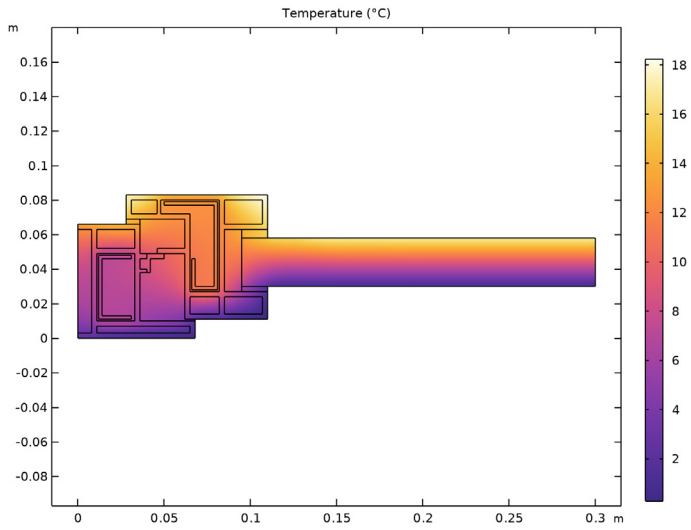

Figure 12: Temperature distribution in the PVC frame with steel reinforcement.

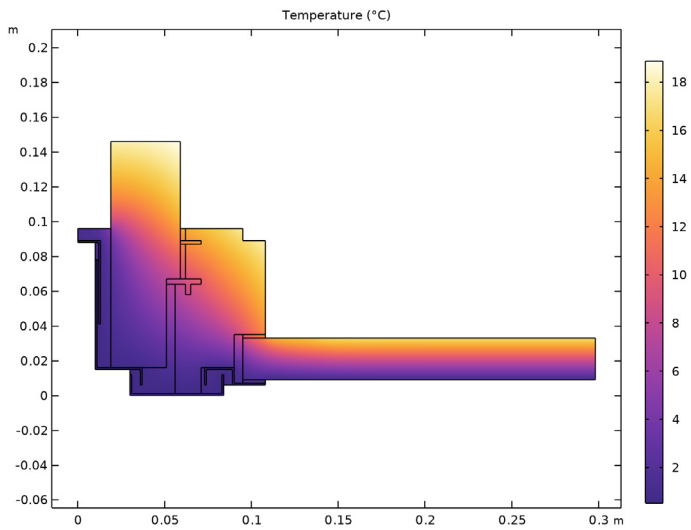

Figure 13: Temperature distribution in the roof window.

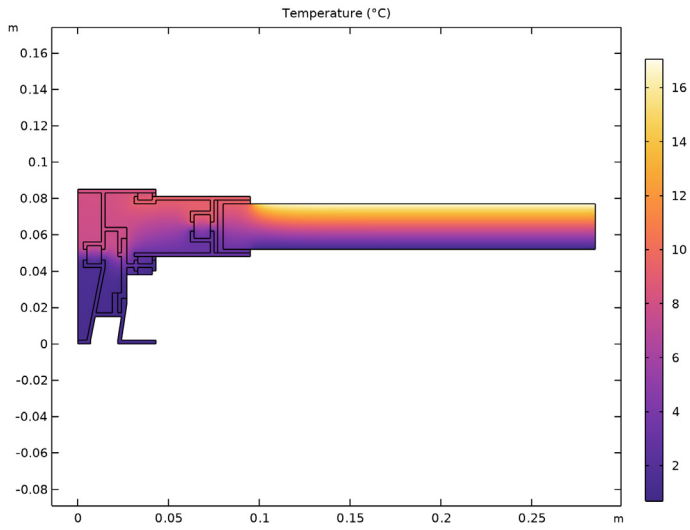

Figure 14: Temperature distribution in the sliding window.

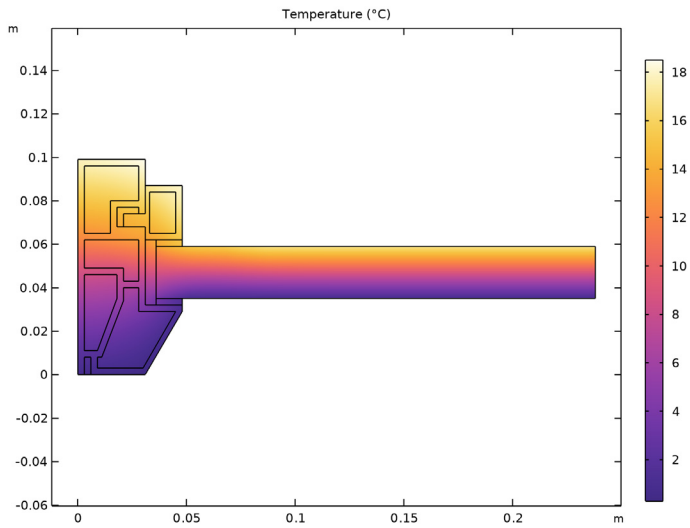

Figure 15: Temperature distribution in the PVC frame.

QUANTITIES OF INTEREST

The quantities of interest are the following:

- The thermal conductance of the entire section L^{2D} given by

$$L^{2D} = \frac{\phi}{T_e - T_i}$$

where ϕ is the heat flow rate through the window (in W/m), $T_e = 0^\circ\text{C}$ is the external temperature and $T_i = 20^\circ\text{C}$ is the internal temperature

- The thermal transmittance of the frame U_f defined by

$$U_f = \frac{L^{2D} - U_p b_p}{b_f}$$

where b_p is the visible width of the panel expressed in meters, b_f is the projected width of the frame section expressed in meters, and U_p is the thermal transmittance of the central area of the panel expressed in $\text{W}/(\text{m}^2 \cdot \text{K})$.

Table 1 to Table 6 compare the numerical results of COMSOL Multiphysics with the expected values provided by ISO 10077-2:2012.

TABLE 1: COMPARISON BETWEEN EXPECTED AND COMPUTED VALUES OF QUANTITIES IN APPLICATION 1.

QUANTITY	EXPECTED VALUE	COMPUTED VALUE	RELATIVE ERROR
L^{2D} (W/(m·K))	0.550	0.557	1.27%
U_f (W/(m ² ·K))	3.22	3.30	2.48%

TABLE 2: COMPARISON BETWEEN EXPECTED AND COMPUTED VALUES OF QUANTITIES IN APPLICATION 2.

QUANTITY	EXPECTED VALUE	COMPUTED VALUE	RELATIVE ERROR
L^{2D} (W/(m·K))	0.263	0.265	0.76%
U_f (W/(m ² ·K))	1.44	1.47	2.1%

TABLE 3: COMPARISON BETWEEN EXPECTED AND COMPUTED VALUES OF QUANTITIES IN APPLICATION 3.

L2D (W/(M·K))	EXPECTED VALUE	COMPUTED VALUE	RELATIVE ERROR
L^{2D} (W/(m·K))	0.424	0.428	0.94%
U_f (W/(m ² ·K))	2.07	2.13	2.9%

TABLE 4: COMPARISON BETWEEN EXPECTED AND COMPUTED VALUES OF QUANTITIES IN APPLICATION 4.

L2D (W/(M·K))	EXPECTED VALUE	COMPUTED VALUE	RELATIVE ERROR
L^{2D} (W/(m·K))	0.408	0.412	0.98%
U_f (W/(m ² ·K))	2.08	2.17	4.3%

TABLE 5: COMPARISON BETWEEN EXPECTED AND COMPUTED VALUES OF QUANTITIES IN APPLICATION 5.

L2D (W/(M·K))	EXPECTED VALUE	COMPUTED VALUE	RELATIVE ERROR
L^{2D} (W/(m·K))	0.659	0.662	0.45%
U_f (W/(m ² ·K))	4.67	4.71	0.85%

TABLE 6: COMPARISON BETWEEN EXPECTED AND COMPUTED VALUES OF QUANTITIES IN APPLICATION 6.

L2D (W/(M·K))	EXPECTED VALUE	COMPUTED VALUE	RELATIVE ERROR
L^{2D} (W/(m·K))	0.285	0.284	0.35%
U_f (W/(m ² ·K))	1.31	1.35	3.1%

The maximum permissible differences to pass this test case are 3% for the thermal conductance and 5% for the thermal transmittance. The measured values are completely coherent and meet the validation criteria.

Reference

1. European Committee for Standardization, *ISO 10077-2:2012, Thermal performance of windows, doors and shutters – Calculation of thermal transmittance – Part 2: Numerical method for frames*, 2012.

Application Library path: Heat_Transfer_Module/
Buildings_and_Constructions/windows_thermal_performances

Modeling Instructions

ROOT

Start by opening the following prepared file. It already contains global definitions, geometries, local variables, selections, operators and material properties.

APPLICATION LIBRARIES

- 1 From the **File** menu, choose **Application Libraries**.
- 2 In the **Application Libraries** window, select **Heat Transfer Module > Buildings and Constructions > windows_thermal_performances_preset** in the tree.
- 3 Click  **Open**.

FIRST WINDOW (COMPI)

Click the  **Zoom Extents** button in the **Graphics** toolbar.

First Window

FIRST WINDOW (COMPI)

In the **Model Builder** window, expand the **First Window (comp1)** node.

DEFINITIONS (COMPI)

Variables 1

- 1 In the **Model Builder** window, expand the **First Window (comp1) > Definitions** node, then click **Variables 1**.
- 2 In the **Settings** window for **Variables**, locate the **Variables** section.
- 3 Add a variable for the thermal conductance of the section to use in postprocessing:

Name	Expression	Unit	Description
L2D	$\text{int_internal}(\text{ht.ntflux} / (\text{Te}-\text{Ti}))$	W/(m·K)	Thermal conductance of the frame

Note that because boundaries linked to the wall and the end of the insulation panel are considered adiabatic, the heat flow rates through the internal and external boundaries are equal (in absolute values).

- 4 In the **Model Builder** window, collapse the **First Window (comp1) > Definitions** node.

HEAT TRANSFER IN SOLIDS AND FLUIDS (HT)

Fluid 1

- 1 In the **Model Builder** window, expand the **Heat Transfer in Solids and Fluids (ht)** node, then click **Fluid 1**.
- 2 Select Domains 2, 5, 6, 10, 12, 14, 15, 17, 18, 20, and 21 only.

Heat Flux 1

- 1 In the **Physics** toolbar, click  **Boundaries** and choose **Heat Flux**.
- 2 In the **Settings** window for **Heat Flux**, locate the **Boundary Selection** section.
- 3 From the **Selection** list, choose **Exterior Side**.
- 4 Locate the **Heat Flux** section. From the **Flux type** list, choose **Convective heat flux**.
- 5 In the h text field, type $1/R_{se}$.
- 6 In the T_{ext} text field, type T_e .

Heat Flux 2

- 1 In the **Physics** toolbar, click  **Boundaries** and choose **Heat Flux**.
- 2 In the **Settings** window for **Heat Flux**, locate the **Boundary Selection** section.
- 3 From the **Selection** list, choose **Interior Side (Flat Area)**.
- 4 Locate the **Heat Flux** section. From the **Flux type** list, choose **Convective heat flux**.
- 5 In the h text field, type $1/R_{si_n}$.
- 6 In the T_{ext} text field, type T_i .

Heat Flux 3

- 1 In the **Physics** toolbar, click  **Boundaries** and choose **Heat Flux**.
- 2 In the **Settings** window for **Heat Flux**, locate the **Boundary Selection** section.
- 3 From the **Selection** list, choose **Interior Side (Corner Area)**.
- 4 Locate the **Heat Flux** section. From the **Flux type** list, choose **Convective heat flux**.
- 5 In the h text field, type $1/R_{si_p}$.
- 6 In the T_{ext} text field, type T_i .
- 7 In the **Model Builder** window, collapse the **Heat Transfer in Solids and Fluids (ht)** node.

STUDY I



The heat flow rate through the interior (or exterior) side of the section needs to be determined to calculate the thermal conductance of the section. In order to have a sufficient precision on this value, the default relative tolerance of the solver has already been modified to 10^{-6} . To access to this value, expand the **Study I** node and click on the **Step 1: Stationary** node. In the **Stationary** settings window, locate the **Study Settings** section.

- 1 In the **Study** toolbar, click  **Compute**.

RESULTS

Change the unit of the temperature results to degrees Celsius.

Preferred Units I

- 1 In the **Results** toolbar, click  **Configurations** and choose **Preferred Units**.
- 2 In the **Settings** window for **Preferred Units**, locate the **Units** section.
- 3 Click  **Add Physical Quantity**.
- 4 In the **Physical Quantity** dialog, select **General > Temperature (K)** in the tree.
- 5 Click **OK**.
- 6 In the **Settings** window for **Preferred Units**, locate the **Units** section.
- 7 In the table, enter the following settings:

Quantity	Unit	Preferred unit
Temperature	K	°C

- 8 Click  **Apply**.

Add a **Global Evaluation** node to calculate the thermal conductance of the section and the thermal transmittance of the frame.

Thermal Conductance of the Section (L2D) I

- 1 In the **Model Builder** window, expand the **Results > Derived Values** node.
- 2 Right-click **Results > Derived Values** and choose **Global Evaluation**.
- 3 In the **Settings** window for **Global Evaluation**, type Thermal Conductance of the Section (L2D) 1 in the **Label** text field.
- 4 Locate the **Expressions** section. In the table, enter the following settings:

Expression	Unit	Description
L2D	W/(m*K)	Thermal Conductance of the Section (L2D)
$(L2D - U_p * p_{v1}) / f_{wtot}$	W/(m ² *K)	Thermal Transmittance of the Frame (U _f)

- 5 Click  **Evaluate**.

TABLE I

- 1 Go to the **Table I** window.

The results should be close to the expected values in [Table 1](#).

RESULTS

Surface 1

- 1 In the **Model Builder** window, expand the **Results > Temperature (ht)** node, then click **Surface 1**.
- 2 In the **Temperature (ht)** toolbar, click  **Plot**.

The current plot group shows the temperature distribution; compare with [Figure 10](#).

The same simulation method is applied on five other benchmarks. The instructions below describe the steps to achieve the calculations.

FIRST WINDOW (COMP1)

In the **Model Builder** window, collapse the **First Window (comp1)** node.

Second Window

SECOND WINDOW (COMP2)

In the **Model Builder** window, expand the **Second Window (comp2)** node.

DEFINITIONS (COMP2)

Variables 2

- 1 In the **Model Builder** window, expand the **Second Window (comp2) > Definitions** node, then click **Variables 2**.
- 2 In the **Settings** window for **Variables**, locate the **Variables** section.
- 3 In the table, enter the following settings:

Name	Expression	Unit	Description
L2D	$\text{int_internal}(\text{ht2.ntflux} / (\text{Te} - \text{Ti}))$	W/(m·K)	Thermal conductance of the frame

- 4 In the **Model Builder** window, collapse the **Second Window (comp2) > Definitions** node.

HEAT TRANSFER IN SOLIDS AND FLUIDS 2 (HT2)

Fluid 1

- 1 In the **Model Builder** window, expand the **Heat Transfer in Solids and Fluids 2 (ht2)** node, then click **Fluid 1**.
- 2 Select Domains 2, 6, 8–10, and 14 only.

Heat Flux 1

- 1 In the **Physics** toolbar, click  **Boundaries** and choose **Heat Flux**.
- 2 In the **Settings** window for **Heat Flux**, locate the **Boundary Selection** section.
- 3 From the **Selection** list, choose **Exterior Side**.
- 4 Locate the **Heat Flux** section. From the **Flux type** list, choose **Convective heat flux**.
- 5 In the h text field, type $1/R_{se}$.
- 6 In the T_{ext} text field, type T_e .

Heat Flux 2

- 1 In the **Physics** toolbar, click  **Boundaries** and choose **Heat Flux**.
- 2 In the **Settings** window for **Heat Flux**, locate the **Boundary Selection** section.
- 3 From the **Selection** list, choose **Interior Side (Flat Area)**.
- 4 Locate the **Heat Flux** section. From the **Flux type** list, choose **Convective heat flux**.
- 5 In the h text field, type $1/R_{si_n}$.
- 6 In the T_{ext} text field, type T_i .

Heat Flux 3

- 1 In the **Physics** toolbar, click  **Boundaries** and choose **Heat Flux**.
- 2 In the **Settings** window for **Heat Flux**, locate the **Boundary Selection** section.
- 3 From the **Selection** list, choose **Interior Side (Corner Area)**.
- 4 Locate the **Heat Flux** section. From the **Flux type** list, choose **Convective heat flux**.
- 5 In the h text field, type $1/R_{si_p}$.
- 6 In the T_{ext} text field, type T_i .
- 7 In the **Model Builder** window, collapse the **Heat Transfer in Solids and Fluids 2 (ht2)** node.

STUDY 2

In the **Study** toolbar, click  **Compute**.

RESULTS

A **Global Evaluation** node is added in order to calculate the thermal conductance of the section and the thermal transmittance of the frame.

Thermal Conductance of the Section (L2D) 2

- 1 In the **Results** toolbar, click  **Global Evaluation**.
- 2 In the **Settings** window for **Global Evaluation**, type Thermal Conductance of the Section (L2D) 2 in the **Label** text field.

3 Locate the **Data** section. From the **Dataset** list, choose **Study 2/Solution 1 (8) (sol1)**.

4 Locate the **Expressions** section. In the table, enter the following settings:

Expression	Unit	Description
L2D	W/(m*K)	Thermal Conductance of the Section (L2D)
$(L2D-Up*pv1)/f_wtot$	W/(m ² *K)	Thermal Transmittance of the Frame (Uf)

5 Click  **Evaluate**.

TABLE 2

1 Go to the **Table 2** window.

The results should be close to the expected values in [Table 2](#).

RESULTS

Surface 1

1 In the **Model Builder** window, expand the **Results > Temperature (ht2)** node, then click **Surface 1**.

2 In the **Temperature (ht2)** toolbar, click  **Plot**.

The current plot group shows the temperature distribution; compare with [Figure 11](#).

SECOND WINDOW (COMP2)

In the **Model Builder** window, collapse the **Second Window (comp2)** node.

Third Window

THIRD WINDOW (COMP3)

In the **Model Builder** window, expand the **Third Window (comp3)** node.

DEFINITIONS (COMP3)

Variables 3

1 In the **Model Builder** window, expand the **Third Window (comp3) > Definitions** node, then click **Variables 3**.

2 In the **Settings** window for **Variables**, locate the **Variables** section.

3 In the table, enter the following settings:

Name	Expression	Unit	Description
L2D	$\text{int_internal}(\text{ht3.ntflux} / (\text{Te}-\text{Ti}))$	W/(m·K)	Thermal conductance of the frame

4 In the **Model Builder** window, collapse the **Third Window (comp3)** > **Definitions** node.

HEAT TRANSFER IN SOLIDS AND FLUIDS 3 (HT3)

Fluid 1

- 1 In the **Model Builder** window, expand the **Heat Transfer in Solids and Fluids 3 (ht3)** node, then click **Fluid 1**.
- 2 Select Domains 2–5, 9, 10, 12, 13, and 15–18 only.

Heat Flux 1

- 1 In the **Physics** toolbar, click  **Boundaries** and choose **Heat Flux**.
- 2 In the **Settings** window for **Heat Flux**, locate the **Boundary Selection** section.
- 3 From the **Selection** list, choose **Exterior Side**.
- 4 Locate the **Heat Flux** section. From the **Flux type** list, choose **Convective heat flux**.
- 5 In the h text field, type $1/R_{se}$.
- 6 In the T_{ext} text field, type T_e .

Heat Flux 2

- 1 In the **Physics** toolbar, click  **Boundaries** and choose **Heat Flux**.
- 2 In the **Settings** window for **Heat Flux**, locate the **Boundary Selection** section.
- 3 From the **Selection** list, choose **Interior Side (Flat Area)**.
- 4 Locate the **Heat Flux** section. From the **Flux type** list, choose **Convective heat flux**.
- 5 In the h text field, type $1/R_{si_n}$.
- 6 In the T_{ext} text field, type T_i .

Heat Flux 3

- 1 In the **Physics** toolbar, click  **Boundaries** and choose **Heat Flux**.
- 2 In the **Settings** window for **Heat Flux**, locate the **Boundary Selection** section.
- 3 From the **Selection** list, choose **Interior Side (Corner Area)**.
- 4 Locate the **Heat Flux** section. From the **Flux type** list, choose **Convective heat flux**.
- 5 In the h text field, type $1/R_{si_p}$.

- 6 In the T_{ext} text field, type T_i .
- 7 In the **Model Builder** window, collapse the **Heat Transfer in Solids and Fluids 3 (ht3)** node.
Edit the default mesh settings to improve the mesh resolution of narrow regions.

MESH 3

In the **Model Builder** window, under **Third Window (comp3)** right-click **Mesh 3** and choose **Edit Physics-Induced Sequence**.

Size

- 1 In the **Model Builder** window, under **Third Window (comp3) > Mesh 3** click **Size**.
- 2 In the **Settings** window for **Size**, click to expand the **Element Size Parameters** section.
- 3 In the **Resolution of narrow regions** text field, type 2.
- 4 In the **Model Builder** window, collapse the **Mesh 3** node.

STUDY 3

In the **Study** toolbar, click  **Compute**.

RESULTS

A **Global Evaluation** node is added in order to calculate the thermal conductance of the section and the thermal transmittance of the frame.

Thermal Conductance of the Section (L2D) 3

- 1 In the **Results** toolbar, click  **Global Evaluation**.
- 2 In the **Settings** window for **Global Evaluation**, type Thermal Conductance of the Section (L2D) 3 in the **Label** text field.
- 3 Locate the **Data** section. From the **Dataset** list, choose **Study 3/Solution 2 (15) (sol2)**.
- 4 Locate the **Expressions** section. In the table, enter the following settings:

Expression	Unit	Description
L2D	W/(m*K)	Thermal Conductance of the Section (L2D)
$(L2D - U_p * p_{v1}) / f_{\text{wtot}}$	W/(m ² *K)	Thermal Transmittance of the Frame (U _f)

- 5 Click  **Evaluate**.

TABLE 3

1 Go to the **Table 3** window.

The results should be close to the expected values in [Table 3](#).

RESULTS

Surface 1

1 In the **Model Builder** window, expand the **Results > Temperature (ht3)** node, then click **Surface 1**.

2 In the **Temperature (ht3)** toolbar, click  **Plot**.

The current plot group shows the temperature distribution; compare with [Figure 12](#).

THIRD WINDOW (COMP3)

In the **Model Builder** window, collapse the **Third Window (comp3)** node.

Fourth Window

FOURTH WINDOW (COMP4)

In the **Model Builder** window, expand the **Fourth Window (comp4)** node.

DEFINITIONS (COMP4)

Variables 4

1 In the **Model Builder** window, expand the **Fourth Window (comp4) > Definitions** node, then click **Variables 4**.

2 In the **Settings** window for **Variables**, locate the **Variables** section.

3 In the table, enter the following settings:

Name	Expression	Unit	Description
L2D	$\text{int_internal}(\text{ht4.ntflux} / (\text{Te}-\text{Ti}))$	W/(m·K)	Thermal conductance of the frame

4 In the **Model Builder** window, collapse the **Fourth Window (comp4) > Definitions** node.

Another mean to improve the accuracy of the solution is to use second order elements for the discretization of the temperature field. Second order elements are particularly efficient for purely conductive models as the ones studied here.

HEAT TRANSFER IN SOLIDS AND FLUIDS 4 (HT4)

- 1 In the **Model Builder** window, under **Fourth Window (comp4)** click **Heat Transfer in Solids and Fluids 4 (ht4)**.
- 2 In the **Settings** window for **Heat Transfer in Solids and Fluids**, click to expand the **Discretization** section.
- 3 From the **Temperature** list, choose **Quadratic Lagrange**.

Fluid 1

- 1 In the **Model Builder** window, expand the **Heat Transfer in Solids and Fluids 4 (ht4)** node, then click **Fluid 1**.
- 2 Select Domains 2, 4, 7, 10, 12, 13, and 15 only.

Heat Flux 1

- 1 In the **Physics** toolbar, click  **Boundaries** and choose **Heat Flux**.
- 2 In the **Settings** window for **Heat Flux**, locate the **Boundary Selection** section.
- 3 From the **Selection** list, choose **Exterior Side**.
- 4 Locate the **Heat Flux** section. From the **Flux type** list, choose **Convective heat flux**.
- 5 In the h text field, type $1/R_{se}$.
- 6 In the T_{ext} text field, type T_e .

Heat Flux 2

- 1 In the **Physics** toolbar, click  **Boundaries** and choose **Heat Flux**.
- 2 In the **Settings** window for **Heat Flux**, locate the **Boundary Selection** section.
- 3 From the **Selection** list, choose **Interior Side (Flat Area)**.
- 4 Locate the **Heat Flux** section. From the **Flux type** list, choose **Convective heat flux**.
- 5 In the h text field, type $1/R_{si_n}$.
- 6 In the T_{ext} text field, type T_i .

Heat Flux 3

- 1 In the **Physics** toolbar, click  **Boundaries** and choose **Heat Flux**.
- 2 In the **Settings** window for **Heat Flux**, locate the **Boundary Selection** section.
- 3 From the **Selection** list, choose **Interior Side (Corner Area)**.
- 4 Locate the **Heat Flux** section. From the **Flux type** list, choose **Convective heat flux**.
- 5 In the h text field, type $1/R_{si_p}$.
- 6 In the T_{ext} text field, type T_i .
- 7 In the **Model Builder** window, collapse the **Heat Transfer in Solids and Fluids 4 (ht4)** node.

Edit the default mesh settings to improve the mesh resolution of narrow regions.

MESH 4

In the **Model Builder** window, under **Fourth Window (comp4)** right-click **Mesh 4** and choose **Edit Physics-Induced Sequence**.

Size

- 1 In the **Model Builder** window, under **Fourth Window (comp4)** > **Mesh 4** click **Size**.
- 2 In the **Settings** window for **Size**, locate the **Element Size Parameters** section.
- 3 In the **Resolution of narrow regions** text field, type 2.
- 4 In the **Model Builder** window, collapse the **Mesh 4** node.

STUDY 4

In the **Study** toolbar, click  **Compute**.

RESULTS

A **Global Evaluation** node is added in order to calculate the thermal conductance of the section and the thermal transmittance of the frame.

Thermal Conductance of the Section (L2D) 4

- 1 In the **Results** toolbar, click  **Global Evaluation**.
- 2 In the **Settings** window for **Global Evaluation**, type Thermal Conductance of the Section (L2D) 4 in the **Label** text field.
- 3 Locate the **Data** section. From the **Dataset** list, choose **Study 4/Solution 3 (22) (sol3)**.
- 4 Locate the **Expressions** section. In the table, enter the following settings:

Expression	Unit	Description
L2D	W/(m*K)	Thermal Conductance of the Section (L2D)
$(L2D-Up*pv1)/f_wtot$	W/(m ² *K)	Thermal Transmittance of the Frame (Uf)

- 5 Click  **Evaluate**.

TABLE 4

- 1 Go to the **Table 4** window.

The results should be close to the expected values in [Table 4](#).

RESULTS

Surface 1

- 1 In the **Model Builder** window, expand the **Results > Temperature (ht4)** node, then click **Surface 1**.
- 2 In the **Temperature (ht4)** toolbar, click  **Plot**.

The current plot group shows the temperature distribution; compare with [Figure 13](#).

FOURTH WINDOW (COMP4)

In the **Model Builder** window, collapse the **Fourth Window (comp4)** node.

Fifth Window

FIFTH WINDOW (COMP5)

In the **Model Builder** window, expand the **Fifth Window (comp5)** node.

DEFINITIONS (COMP5)

Variables 5

- 1 In the **Model Builder** window, expand the **Fifth Window (comp5) > Definitions** node, then click **Variables 5**.
- 2 In the **Settings** window for **Variables**, locate the **Variables** section.
- 3 In the table, enter the following settings:

Name	Expression	Unit	Description
L2D	$\text{int_internal}(\text{ht5.ntflux} / (\text{Te}-\text{Ti}))$	W/(m·K)	Thermal conductance of the frame

- 4 In the **Model Builder** window, collapse the **Fifth Window (comp5) > Definitions** node.

HEAT TRANSFER IN SOLIDS AND FLUIDS 5 (HT5)

Fluid 1

- 1 In the **Model Builder** window, expand the **Heat Transfer in Solids and Fluids 5 (ht5)** node, then click **Fluid 1**.
- 2 Select Domains 2, 5, 6, 8, 14, 15, and 17 only.

Heat Flux 1

- 1 In the **Physics** toolbar, click  **Boundaries** and choose **Heat Flux**.

- 2 In the **Settings** window for **Heat Flux**, locate the **Boundary Selection** section.
- 3 From the **Selection** list, choose **Exterior Side**.
- 4 Locate the **Heat Flux** section. From the **Flux type** list, choose **Convective heat flux**.
- 5 In the h text field, type $1/R_{se}$.
- 6 In the T_{ext} text field, type T_e .

Heat Flux 2

- 1 In the **Physics** toolbar, click  **Boundaries** and choose **Heat Flux**.
- 2 In the **Settings** window for **Heat Flux**, locate the **Boundary Selection** section.
- 3 From the **Selection** list, choose **Interior Side (Flat Area)**.
- 4 Locate the **Heat Flux** section. From the **Flux type** list, choose **Convective heat flux**.
- 5 In the h text field, type $1/R_{si_n}$.
- 6 In the T_{ext} text field, type T_i .

Heat Flux 3

- 1 In the **Physics** toolbar, click  **Boundaries** and choose **Heat Flux**.
- 2 In the **Settings** window for **Heat Flux**, locate the **Boundary Selection** section.
- 3 From the **Selection** list, choose **Interior Side (Corner Area)**.
- 4 Locate the **Heat Flux** section. From the **Flux type** list, choose **Convective heat flux**.
- 5 In the h text field, type $1/R_{si_p}$.
- 6 In the T_{ext} text field, type T_i .
- 7 In the **Model Builder** window, collapse the **Heat Transfer in Solids and Fluids 5 (ht5)** node.

STUDY 5

In the **Study** toolbar, click  **Compute**.

RESULTS

A **Global Evaluation** node is added in order to calculate the thermal conductance of the section and the thermal transmittance of the frame.

Thermal Conductance of the Section (L2D) 5

- 1 In the **Results** toolbar, click  **Global Evaluation**.
- 2 In the **Settings** window for **Global Evaluation**, type Thermal Conductance of the Section (L2D) 5 in the **Label** text field.
- 3 Locate the **Data** section. From the **Dataset** list, choose **Study 5/Solution 4 (29) (sol4)**.

4 Locate the **Expressions** section. In the table, enter the following settings:

Expression	Unit	Description
L2D	W/(m*K)	Thermal Conductance of the Section (L2D)
$(L2D - U_p * p_{v1}) / f_{wtot}$	W/(m ² *K)	Thermal Transmittance of the Frame (Uf)

5 Click  **Evaluate**.

TABLE 5

1 Go to the **Table 5** window.

The results should be close to the expected values in [Table 5](#).

RESULTS

Surface 1

1 In the **Model Builder** window, expand the **Results > Temperature (ht5)** node, then click **Surface 1**.

2 In the **Temperature (ht5)** toolbar, click  **Plot**.

The current plot group shows the temperature distribution; compare with [Figure 14](#).

FIFTH WINDOW (COMP5)

In the **Model Builder** window, collapse the **Fifth Window (comp5)** node.

Sixth Window

SIXTH WINDOW (COMP6)

In the **Model Builder** window, expand the **Sixth Window (comp6)** node.

DEFINITIONS (COMP6)

Variables 6

1 In the **Model Builder** window, expand the **Sixth Window (comp6) > Definitions** node, then click **Variables 6**.

2 In the **Settings** window for **Variables**, locate the **Variables** section.

3 In the table, enter the following settings:

Name	Expression	Unit	Description
L2D	$\text{int_internal}(\text{ht6.ntflux} / (\text{Te}-\text{Ti}))$	W/(m·K)	Thermal conductance of the frame

4 In the **Model Builder** window, collapse the **Sixth Window (comp6) > Definitions** node.

HEAT TRANSFER IN SOLIDS AND FLUIDS 6 (HT6)

Fluid 1

- 1 In the **Model Builder** window, expand the **Heat Transfer in Solids and Fluids 6 (ht6)** node, then click **Fluid 1**.
- 2 Select Domains 2–7, 9, and 10 only.

Heat Flux 1

- 1 In the **Physics** toolbar, click  **Boundaries** and choose **Heat Flux**.
- 2 In the **Settings** window for **Heat Flux**, locate the **Boundary Selection** section.
- 3 From the **Selection** list, choose **Exterior Side**.
- 4 Locate the **Heat Flux** section. From the **Flux type** list, choose **Convective heat flux**.
- 5 In the h text field, type $1/R_{se}$.
- 6 In the T_{ext} text field, type T_e .

Heat Flux 2

- 1 In the **Physics** toolbar, click  **Boundaries** and choose **Heat Flux**.
- 2 In the **Settings** window for **Heat Flux**, locate the **Boundary Selection** section.
- 3 From the **Selection** list, choose **Interior Side (Flat Area)**.
- 4 Locate the **Heat Flux** section. From the **Flux type** list, choose **Convective heat flux**.
- 5 In the h text field, type $1/R_{si_n}$.
- 6 In the T_{ext} text field, type T_i .

Heat Flux 3

- 1 In the **Physics** toolbar, click  **Boundaries** and choose **Heat Flux**.
- 2 In the **Settings** window for **Heat Flux**, locate the **Boundary Selection** section.
- 3 From the **Selection** list, choose **Internal (Corner Area)**.
- 4 Locate the **Heat Flux** section. From the **Flux type** list, choose **Convective heat flux**.
- 5 In the h text field, type $1/R_{si_p}$.

6 In the T_{ext} text field, type T_i .

7 In the **Model Builder** window, collapse the **Heat Transfer in Solids and Fluids 6 (ht6)** node.

STUDY 6

In the **Study** toolbar, click  **Compute**.

RESULTS

A **Global Evaluation** node is added in order to calculate the thermal conductance of the section and the thermal transmittance of the frame.

Thermal Conductance of the Section (L2D) 6

1 In the **Results** toolbar, click  **Global Evaluation**.

2 In the **Settings** window for **Global Evaluation**, type Thermal Conductance of the Section (L2D) 6 in the **Label** text field.

3 Locate the **Data** section. From the **Dataset** list, choose **Study 6/Solution 5 (36) (sol5)**.

4 Locate the **Expressions** section. In the table, enter the following settings:

Expression	Unit	Description
L2D	W/(m*K)	Thermal Conductance of the Section (L2D)
$(L2D - U_p * p_{v1}) / f_{wtot}$	W/(m ² *K)	Thermal Transmittance of the Frame (U _f)

5 Click  **Evaluate**.

TABLE 6

1 Go to the **Table 6** window.

The results should be close to the expected values in [Table 6](#).

RESULTS

Surface 1

1 In the **Model Builder** window, expand the **Results > Temperature (ht6)** node, then click **Surface 1**.

2 In the **Temperature (ht6)** toolbar, click  **Plot**.

The current plot group shows the temperature distribution; compare with [Figure 15](#).