



Model created in COMSOL Multiphysics 6.4

Thermal Contact Resistance Between an Electronic Package and a Heat Sink

Introduction

This example reproduces parts of the study of [Ref. 1](#) on the thermal contact resistance at the interface between a heat sink and an electronic package. As shown in [Figure 1](#), eight cooling fins equip the cylindrical heat sink and contact is made at the radial boundaries of the package.

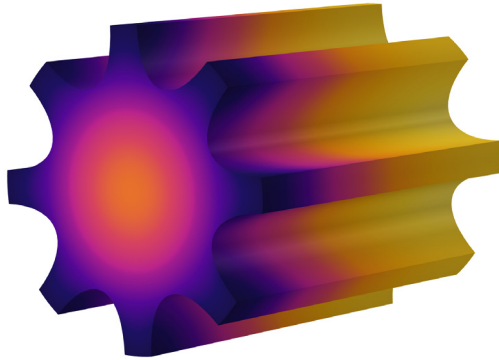

Figure 1: Heat sink with cooling fins around a cylindrical package.

The efficiency of the device depends on the cooling of the fins and the heat transfer from the package to the heat sink. This application focuses on the heat transfer through the contact interface where four parameters influence the joint conductance: contact pressure, microhardness of the softer material, surface roughness, and surface roughness slope.

Model Definition

The electronic package is simplified into a cylinder with radius 1 cm and height 5 cm and is made of silicon. The aluminum heat sink contains eight fins reaching a distance of 2 cm

from the cylinder axis. Only 1/16th of the geometry is represented thanks to the symmetries shown in [Figure 2](#).

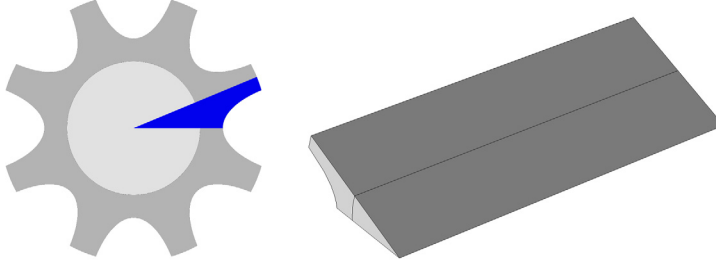

Figure 2: Symmetry and simplification of the geometry.

The package produces a total heat source of 5 W. To dissipate it, air at 293.15 K and 1 atm resulting from a cooling fan, cools the heat sink fins by forced convection. The COMSOL Multiphysics built-in local heat transfer coefficient is used, assuming that the velocity of air is 8.5 m/s. The extremities of the device are thermally insulated.

At the contact interface, the thermal contact conductance h is expressed by ([Ref. 1](#)):

$$h = h_{\text{constriction}} + h_{\text{gap}}$$

$$h_{\text{constriction}} = 1.25k_s \frac{m}{\sigma} \left(\frac{P}{H_c} \right)^{0.95}$$

$$h_{\text{gap}} = \frac{k_{\text{gap}}}{Y + M_{\text{gap}}}$$

where the contact pressure, p , the aluminum microhardness, H_{mic} , the surface roughness, σ , and the roughness slope, m , are the four parameters studied here by a parametric sweep. [Table 1](#) describes the quantities involved in these relations and gives the values ([Ref. 1](#)) used in the reference case.

The reference case uses the following additional relation for p/H_{mic} (4.16 in [Ref. 2](#)):

$$\frac{p}{H_{\text{mic}}} = \left(\frac{p}{c_1 \left(1.62 \frac{\sigma}{\sigma_0} m \right)^{c_2}} \right)^{\frac{1}{1 + 0.071c_2}}$$

where c_1 , c_2 , and σ_0 are detailed in [Table 1](#).

TABLE 1: QUANTITIES AND REFERENCE VALUES FOR COMPUTING THE JOINT CONDUCTANCE.

SYMBOL	QUANTITY	REFERENCE VALUE
p	Contact pressure	25 kPa
H_{mic}	Microhardness	0.25 MPa
σ	Surface roughness	2 μm
m	Surface roughness slope	0.12
k_s	Contact conductivity	-
k_{gap}	Gap conductivity	0.031 W/(m·K)
Y	Microscopic distance between mean planes	-
M_{gap}	Gas rarefaction parameter	-
c_1	Vickers correlation coefficient	6.23 GPa
c_2	Vickers size index	-0.23
σ_0	Reference roughness	1 μm

Results and Discussion

[Figure 3](#) shows the temperature profile obtained with the reference values. Near the fan, the temperature of the fins are about 483 K. It increases to reach 489 K at the opposite extremity.

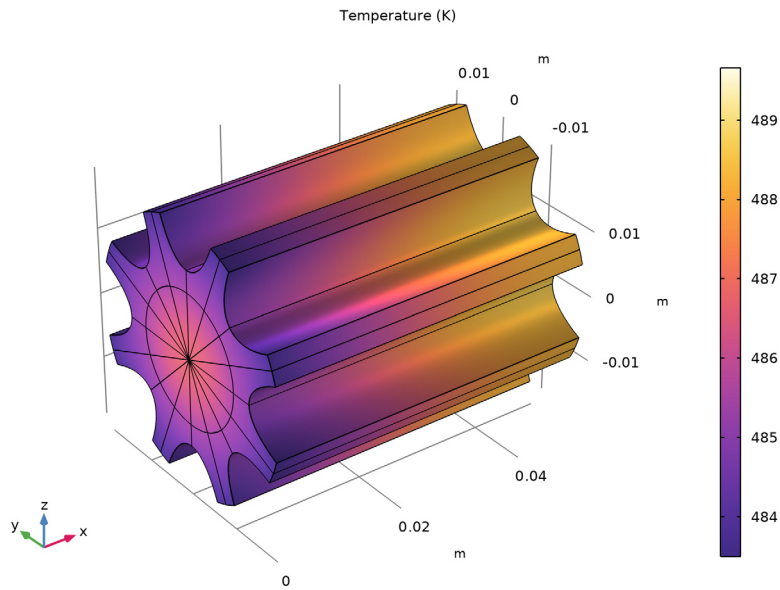

Figure 3: Temperature profile with reference values for the parameters.

Figure 4 and Figure 5 plot the evolution of the constriction resistance according to p and H_{mic} and to σ and m . Figure 6 and Figure 7 display the analogous results for the gap resistance.

The contour curves are the same as in Ref. 1. Because the study in Ref. 1 is not in 3D but simplified into a 2D model, the values of contact resistance differ slightly. The last figure shows almost constant values in the vertical direction, meaning that m has little influence on the gap conductance.

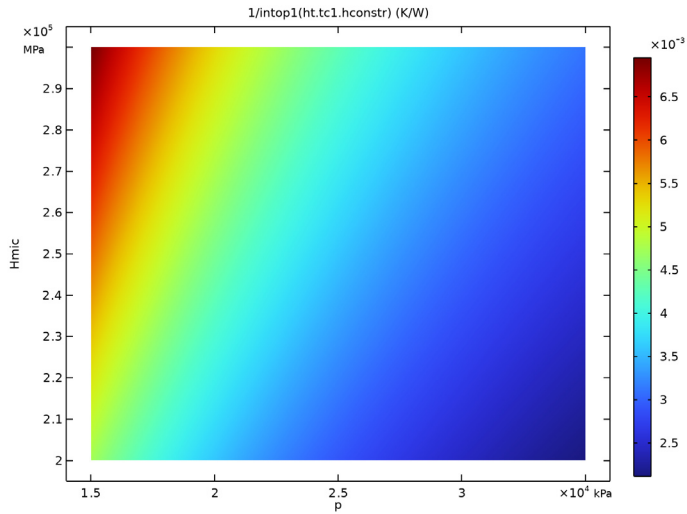

Figure 4: Constriction resistance depending on contact pressure (x-axis) and microhardness (y-axis).

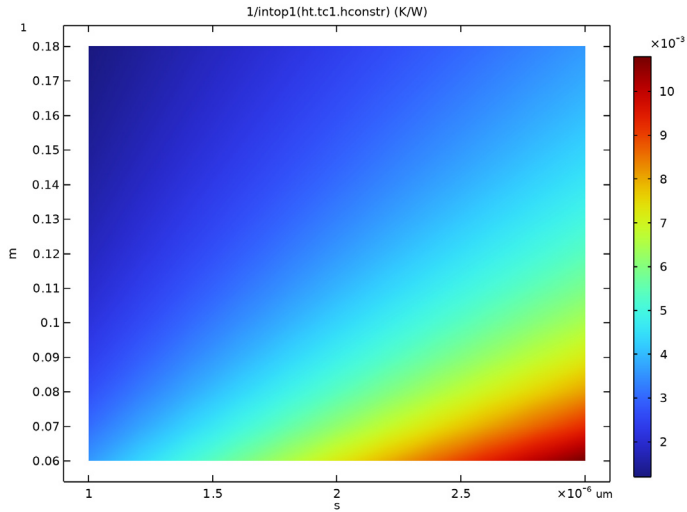

Figure 5: Constriction resistance depending on roughness (x-axis) and roughness slope (y-axis).

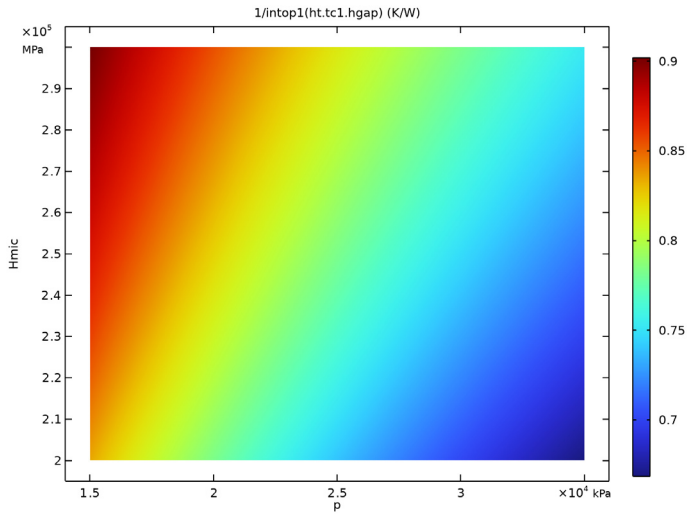

Figure 6: Gap resistance depending on contact pressure (x-axis) and microhardness (y-axis).

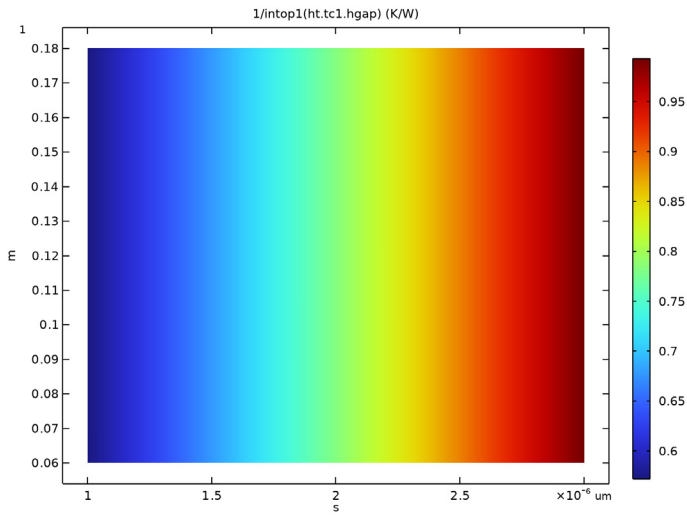

Figure 7: Gap resistance depending on roughness (x-axis) and roughness slope (y-axis).

References

1. M. Grujcic, C.L. Zhao, and E.C. Dusel, “The Effect of Thermal Resistance on Heat Management in the Electronic Packaging,” *Applied Surface Science*, vol. 246, pp. 290–302, 2005.
 2. A. Bejan and A. D. Kraus, eds., *Heat Transfer Handbook*, John Wiley & Sons, 2003.
-

Application Library path: Heat_Transfer_Module/
Thermal_Contact_and_Friction/
thermal_contact_electronic_package_heat_sink



Modeling Instructions

From the **File** menu, choose **New**.

NEW

In the **New** window, click  **Model Wizard**.

MODEL WIZARD

- 1 In the **Model Wizard** window, click  **3D**.
- 2 In the **Select Physics** tree, select **Heat Transfer > Heat Transfer in Solids (ht)**.
- 3 Click **Add**.
- 4 Click  **Study**.
- 5 In the **Select Study** tree, select **General Studies > Stationary**.
- 6 Click  **Done**.

GLOBAL DEFINITIONS

Parameters 1

- 1 In the **Model Builder** window, under **Global Definitions** click **Parameters 1**.
- 2 In the **Settings** window for **Parameters**, locate the **Parameters** section.



3 In the table, enter the following settings:

Name	Expression	Value	Description
p	25[kPa]	25000 Pa	Contact pressure
Hmic	0.25[MPa]	2.5E5 Pa	Aluminum microhardness
s	2[um]	2E-6 m	Surface roughness
m	0.12	0.12	Surface roughness slope

GEOMETRY I

Only 1/16th of the geometry is represented due to symmetry considerations in the device.

Work Plane 1 (wp1)

- 1 In the **Geometry** toolbar, click  **Work Plane**.
- 2 In the **Settings** window for **Work Plane**, locate the **Plane Definition** section.
- 3 From the **Plane** list, choose **yz-plane**.
- 4 Click  **Go to Plane Geometry**.

Work Plane 1 (wp1) > Circle 1 (c1)

- 1 In the **Work Plane** toolbar, click  **Circle**.
- 2 In the **Settings** window for **Circle**, locate the **Size and Shape** section.
- 3 In the **Radius** text field, type 2[cm].
- 4 In the **Sector angle** text field, type 360/16.
- 5 Click to expand the **Layers** section. In the table, enter the following settings:

Layer name	Thickness (m)
Layer 1	1[cm]

- 6 Click  **Build Selected**.

Work Plane 1 (wp1) > Quadratic Bézier 1 (qbl)



- 1 In the **Work Plane** toolbar, click  **More Primitives** and choose **Quadratic Bézier**.
- 2 In the **Settings** window for **Quadratic Bézier**, locate the **Control Points** section.
- 3 In row **1**, set **xw** to 2[cm], and **yw** to 0.6[cm].
- 4 In row **2**, set **xw** to 0.4[cm].
- 5 In row **3**, set **xw** to 2[cm], and **yw** to -0.6[cm].

Work Plane 1 (wp1) > Line Segment 1 (ls1)

- 1 In the **Work Plane** toolbar, click  **More Primitives** and choose **Line Segment**.

- 2 In the **Settings** window for **Line Segment**, locate the **Starting Point** section.
- 3 From the **Specify** list, choose **Coordinates**.
- 4 Locate the **Endpoint** section. From the **Specify** list, choose **Coordinates**.
- 5 Locate the **Starting Point** section. In the **xw** text field, type 2[cm].
- 6 In the **yw** text field, type 0.6[cm].
- 7 Locate the **Endpoint** section. In the **xw** text field, type 2[cm].
- 8 In the **yw** text field, type -0.6[cm].

Work Plane 1 (wp1) > Convert to Solid 1 (csol1)

- 1 In the **Work Plane** toolbar, click  **Conversions** and choose **Convert to Solid**.
- 2 Select the objects **ls1** and **qb1** only.
- 3 In the **Settings** window for **Convert to Solid**, click  **Build Selected**.
- 4 Click the  **Zoom Extents** button in the **Graphics** toolbar.

So far, the geometry should look like the figure below.

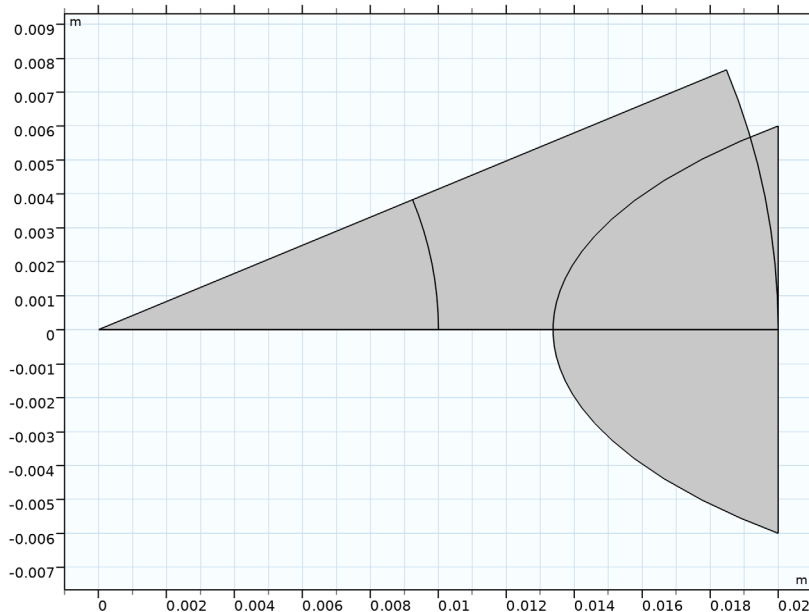

Work Plane 1 (wp1) > Partition Objects 1 (par1)

- 1 In the **Work Plane** toolbar, click  **Booleans and Partitions** and choose **Partition Objects**.
- 2 Select the object **cl** only.

- 3 In the **Settings** window for **Partition Objects**, locate the **Partition Objects** section.
- 4 Click to select the  **Activate Selection** toggle button for **Tool objects**.
- 5 Select the object **cs01** only.

Work Plane 1 (wp1) > Delete Entities 1 (del1)

- 1 In the **Model Builder** window, right-click **Plane Geometry** and choose **Delete Entities**.
- 2 In the **Settings** window for **Delete Entities**, locate the **Entities or Objects to Delete** section.
- 3 From the **Geometric entity level** list, choose **Domain**.
- 4 On the object **par1**, select Domain 3 only.
- 5 Click  **Build Selected**.

Work Plane 1 (wp1)

- 1 In the **Model Builder** window, under **Component 1 (comp1) > Geometry 1** click **Work Plane 1 (wp1)**.
- 2 In the **Settings** window for **Work Plane**, click  **Build Selected**.

Extrude 1 (ext1)

- 1 In the **Geometry** toolbar, click  **Extrude**.
- 2 In the **Settings** window for **Extrude**, locate the **Distances** section.
- 3 In the table, enter the following settings:



Distances (m)
5 [cm]

- 4 In the **Geometry** toolbar, click  **Build All**.

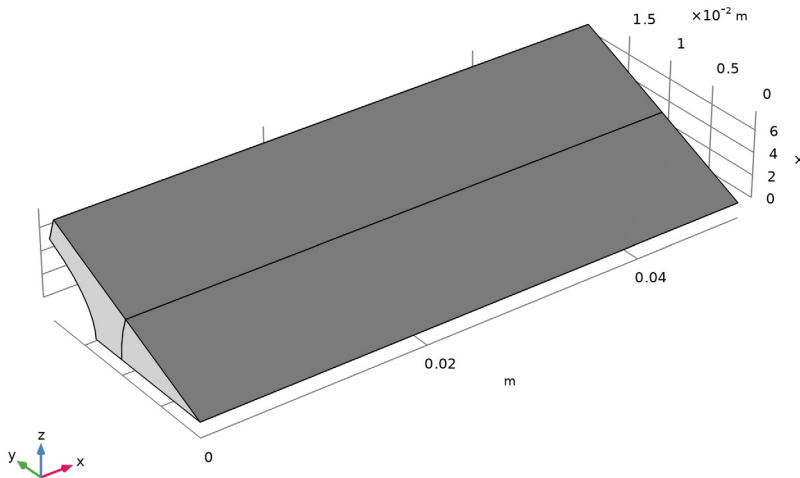
- 5 Click the  **Zoom Extents** button in the **Graphics** toolbar.



ADD MATERIAL

- 1 In the **Materials** toolbar, click  **Add Material** to open the **Add Material** window.
- 2 Go to the **Add Material** window.
- 3 In the tree, select **Built-in** > **Aluminum**.
- 4 Click the **Add to Component** button in the window toolbar.
- 5 In the tree, select **Built-in** > **Silicon**.
- 6 Click the **Add to Component** button in the window toolbar.
- 7 In the **Materials** toolbar, click  **Add Material** to close the **Add Material** window.

MATERIALS

Silicon (mat2)

Select Domain 1 only.

HEAT TRANSFER IN SOLIDS (HT)

Heat Source 1

- 1 In the **Physics** toolbar, click  **Domains** and choose **Heat Source**.

- 2 Select Domain 1 only.
- 3 In the **Settings** window for **Heat Source**, locate the **Heat Source** section.
- 4 From the **Heat source** list, choose **Heat rate**.
- 5 In the P_0 text field, type 5[W].

Heat Flux 1

- 1 In the **Physics** toolbar, click  **Boundaries** and choose **Heat Flux**.
- 2 Select Boundaries 8 and 9 only.
- 3 In the **Settings** window for **Heat Flux**, locate the **Heat Flux** section.
- 4 From the **Flux type** list, choose **Convective heat flux**.
- 5 From the **Heat transfer coefficient** list, choose **External forced convection**.
- 6 From the list, choose **Plate, local transfer coefficient**.
- 7 In the x_{pl} text field, type x.
- 8 In the U text field, type 8.5[m/s].

Thermal Contact 1



- 1 In the **Physics** toolbar, click  **Boundaries** and choose **Thermal Contact**.
- 2 Select Boundary 5 only.
- 3 In the **Settings** window for **Thermal Contact**, locate the **Thermal Contact** section.
- 4 From the h_g list, choose **Parallel-plate gap gas conductance**.
- 5 Locate the **Contact Surface Properties** section. In the σ_{asp} text field, type s.
- 6 In the m_{asp} text field, type m.
- 7 In the p text field, type p.
- 8 In the H_c text field, type Hmic.
- 9 Click to expand the **Gap Properties** section. From the k_{gap} list, choose **User defined**. In the associated text field, type 0.031[W/(m*K)].
- 10 In the p_{gap} text field, type 50[Torr].
- 11 In the α text field, type 0.78.

Symmetry 1

- 1 In the **Physics** toolbar, click  **Boundaries** and choose **Symmetry**.
- 2 Select Boundaries 2, 3, 6, and 7 only.

MESH I

Free Triangular I

- 1 In the **Mesh** toolbar, click  **More Generators** and choose **Free Triangular**.
- 2 Select Boundaries 1 and 4 only.
- 3 In the **Settings** window for **Free Triangular**, click  **Build Selected**.

Swept I

- 1 In the **Mesh** toolbar, click  **Swept**.
- 2 In the **Settings** window for **Swept**, click  **Build All**.

STUDY I

In the **Study** toolbar, click  **Compute**.

RESULTS



Temperature (ht)

The first default plot shows the temperature profile. To visualize the overall device, create a **Sector 3D** dataset according to the steps below.

Sector 3D I



- 1 In the **Results** toolbar, click  **More Datasets** and choose **Sector 3D**.
- 2 In the **Settings** window for **Sector 3D**, locate the **Axis Data** section.
- 3 In row **Point 2**, set **X** to 1, and **z** to 0.
- 4 Locate the **Symmetry** section. In the **Number of sectors** text field, type 16.
- 5 From the **Transformation** list, choose **Rotation and reflection**.
- 6 Find the **Radial direction of reflection plane** subsection. In the **X** text field, type 0.
- 7 In the **Z** text field, type 1.

Temperature (ht)

- 1 In the **Model Builder** window, under **Results** click **Temperature (ht)**.
- 2 In the **Settings** window for **3D Plot Group**, locate the **Data** section.
- 3 From the **Dataset** list, choose **Sector 3D I**.
- 4 In the **Temperature (ht)** toolbar, click  **Plot**.
- 5 Click the  **Zoom Extents** button in the **Graphics** toolbar.



To observe the influence of the two parameters s and m on the thermal contact conductance, create the next parametric study.

ADD STUDY

- 1 In the **Home** toolbar, click  **Add Study** to open the **Add Study** window.
- 2 Go to the **Add Study** window.
- 3 Find the **Studies** subsection. In the **Select Study** tree, select **General Studies > Stationary**.
- 4 Click the **Add Study** button in the window toolbar.
- 5 In the **Home** toolbar, click  **Add Study** to close the **Add Study** window.

STUDY 2

Parametric Sweep

- 1 In the **Study** toolbar, click  **Parametric Sweep**.
- 2 In the **Settings** window for **Parametric Sweep**, locate the **Study Settings** section.
- 3 From the **Sweep type** list, choose **All combinations**.
- 4 Click  **Add**.
- 5 From the list in the **Parameter name** column, choose **s (Surface roughness)**, then specify values and unit as follows:

Parameter name	Parameter value list	Parameter unit
s (Surface roughness)	range (1, 0.2, 3)	um

- 6 Click  **Add**.
- 7 From the list in the **Parameter name** column, choose **m (Surface roughness slope)**, then specify values and unit as follows:

Parameter name	Parameter value list	Parameter unit
m (Surface roughness slope)	range (0.06, 0.01, 0.18)	1

For assistance in entering ranges of different kinds in the **Parameter value list** column, click the **Range** button to launch the **Range** dialog.

- 8 In the **Model Builder** window, click **Study 2**.
- 9 In the **Settings** window for **Study**, locate the **Study Settings** section.
- 10 Clear the **Generate default plots** checkbox.

Before performing the study, define an **Integration** operator at the contact interface to calculate the total constriction and gap resistance.

DEFINITIONS

Integration 1 (intop1)

- 1 In the **Definitions** toolbar, click  **Nonlocal Couplings** and choose **Integration**.
- 2 In the **Settings** window for **Integration**, locate the **Source Selection** section.
- 3 From the **Geometric entity level** list, choose **Boundary**.
- 4 Select Boundary 5 only.

STUDY 2

In the **Study** toolbar, click  **Compute**.

RESULTS

Constriction Resistance (s, m)

- 1 In the **Results** toolbar, click  **Global Evaluation**.
- 2 In the **Settings** window for **Global Evaluation**, type Constriction Resistance (s, m) in the **Label** text field.
- 3 Locate the **Data** section. From the **Dataset** list, choose **Study 2/Solution 2 (sol2)**.
- 4 Locate the **Expressions** section. In the table, enter the following settings:

Expression	Unit	Description
1/intop1(ht.tc1.hconstr)	K/W	

- 5 Click  **Evaluate**.

TABLE 1

- 1 Go to the **Table 1** window.
Reproduce [Figure 5](#) as follows.
- 2 Click the **Table Surface** button in the window toolbar.

RESULTS

Constriction Resistance (s, m)

- 1 In the **Model Builder** window, under **Results** click **2D Plot Group 2**.
- 2 In the **Settings** window for **2D Plot Group**, type Constriction Resistance (s, m) in the **Label** text field.
- 3 Click the  **Zoom Extents** button in the **Graphics** toolbar.

Gap Resistance (s, m)

- 1 In the **Results** toolbar, click  **Global Evaluation**.
- 2 In the **Settings** window for **Global Evaluation**, type Gap Resistance (s, m) in the **Label** text field.
- 3 Locate the **Data** section. From the **Dataset** list, choose **Study 2/Solution 2 (sol2)**.
- 4 Locate the **Expressions** section. In the table, enter the following settings:

Expression	Unit	Description
1/intop1(ht.tc1.hgap)	K/W	

- 5 Click  **Evaluate**.

TABLE 2



- 1 Go to the **Table 2** window.
- 2 Click the **Table Surface** button in the window toolbar.

RESULTS

Gap Resistance (s, m)

- 1 In the **Model Builder** window, under **Results** click **2D Plot Group 3**.
- 2 In the **Settings** window for **2D Plot Group**, type Gap Resistance (s, m) in the **Label** text field.
- 3 Click the  **Zoom Extents** button in the **Graphics** toolbar.

ADD STUDY

- 1 In the **Home** toolbar, click  **Add Study** to open the **Add Study** window.
- 2 Go to the **Add Study** window.
- 3 Find the **Studies** subsection. In the **Select Study** tree, select **General Studies > Stationary**.
- 4 Click the **Add Study** button in the window toolbar.
- 5 In the **Home** toolbar, click  **Add Study** to close the **Add Study** window.

STUDY 3

Parametric Sweep

- 1 In the **Study** toolbar, click  **Parametric Sweep**.
- 2 In the **Settings** window for **Parametric Sweep**, locate the **Study Settings** section.
- 3 From the **Sweep type** list, choose **All combinations**.

4 Click **+** **Add**.

5 From the list in the **Parameter name** column, choose **p (Contact pressure)**, then specify values and unit as follows:

Parameter name	Parameter value list	Parameter unit
p (Contact pressure)	range (15 , 1 , 35)	kPa

6 Click **+** **Add**.

7 From the list in the **Parameter name** column, choose **Hmic (Aluminum microhardness)**, then specify values and unit as follows:

Parameter name	Parameter value list	Parameter unit
Hmic (Aluminum microhardness)	range (0.2 , 0.01 , 0.3)	MPa

For assistance in entering ranges of different kinds in the **Parameter value list** column, click the **Range** button to launch the **Range** dialog.

8 In the **Model Builder** window, click **Study 3**.

9 In the **Settings** window for **Study**, locate the **Study Settings** section.

10 Clear the **Generate default plots** checkbox.

11 In the **Study** toolbar, click **=** **Compute**.

RESULTS

Constriction Resistance (p, Hmic)

1 In the **Results** toolbar, click **8.5** **Global Evaluation**.

2 In the **Settings** window for **Global Evaluation**, type Constriction Resistance (p, Hmic) in the **Label** text field.

3 Locate the **Data** section. From the **Dataset** list, choose **Study 3/Solution 3 (sol3)**.

4 Locate the **Expressions** section. In the table, enter the following settings:

Expression	Unit	Description
1/intop1(ht.tc1.hconstr)	K/W	

5 Click **=** **Evaluate**.

TABLE 3

1 Go to the **Table 3** window.

2 Click the **Table Surface** button in the window toolbar.

RESULTS

Constriction Resistance (p, Hmic)

- 1 In the **Model Builder** window, under **Results** click **2D Plot Group 4**.
- 2 In the **Settings** window for **2D Plot Group**, type Constriction Resistance (p, Hmic) in the **Label** text field.
- 3 Click the  **Zoom Extents** button in the **Graphics** toolbar.

Gap Resistance (p, Hmic)

- 1 In the **Results** toolbar, click  **Global Evaluation**.
- 2 In the **Settings** window for **Global Evaluation**, type Gap Resistance (p, Hmic) in the **Label** text field.
- 3 Locate the **Data** section. From the **Dataset** list, choose **Study 3/Solution 3 (sol3)**.
- 4 Locate the **Expressions** section. In the table, enter the following settings:

Expression	Unit	Description
$1/\text{intop1}(\text{ht.tc1.hgap})$	K/W	

- 5 Click  **Evaluate**.

TABLE 4

- 1 Go to the **Table 4** window.
- 2 Click the **Table Surface** button in the window toolbar.

RESULTS

Gap Resistance (p, Hmic)

- 1 In the **Model Builder** window, under **Results** click **2D Plot Group 5**.
- 2 In the **Settings** window for **2D Plot Group**, type Gap Resistance (p, Hmic) in the **Label** text field.
- 3 Click the  **Zoom Extents** button in the **Graphics** toolbar.

In order to visualize the temperature on each side of the thermal contact, follow the next steps.

RESULT TEMPLATES

- 1 In the **Results** toolbar, click  **Result Templates** to open the **Result Templates** window.
- 2 Go to the **Result Templates** window.

- 3 In the tree, select **Study 1/Solution 1 (sol1) > Heat Transfer in Solids > Contact Temperature (ht)**.
- 4 Click the **Add Result Template** button in the window toolbar.
- 5 In the **Results** toolbar, click  **Result Templates** to close the **Result Templates** window.

RESULTS

Contact Temperature (ht)

- 1 In the **Settings** window for **3D Plot Group**, locate the **Data** section.
- 2 From the **Dataset** list, choose **Sector 3D 1**.