



Model created in COMSOL Multiphysics 6.4

Thermal Bridges in Building Construction — 3D Structure Between Two Floors

Introduction

The European standard EN ISO 10211:2017 for thermal bridges in building constructions provides four test cases — two 2D and two 3D — for validating a numerical method (Ref. 1). If the values obtained by a method conform to the results of all these four cases, the method is classified as a *three-dimensional steady-state high precision method*.

COMSOL Multiphysics successfully passes all the test cases described by the standard and is hence classified as a *three-dimensional steady-state high precision method*. This document presents an implementation of the first 3D model (Case 3).

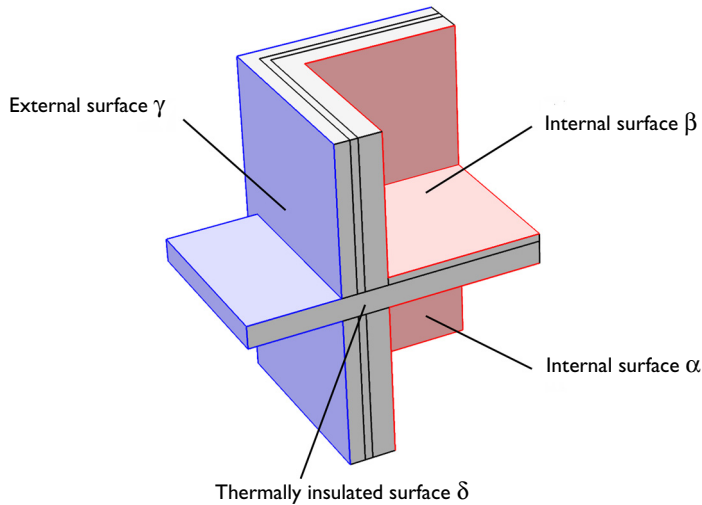

Figure 1: Geometry and boundary conditions of ISO 10211:2017 test case 3.

This tutorial studies the heat conduction in a building structure separating two floors from the external environment. The structure's surfaces are divided into four parts:

- the lower level, α ;
- the upper level, β ;
- the outside, γ ;
- and the remaining thermally insulated surfaces, δ .

The values of interest for validation are the lowest temperatures at surfaces α and β , and the heat fluxes through α , β , and γ .

Model Definition

Figure 1 illustrates the geometry. The external surface is at 0°C and the interior surface is at 20°C. Four materials with distinct thermal conductivities k are used in the structure. The horizontal block separating the two floors has the highest thermal conductivity (2.5 W/(m·K)). It crosses the wall, thereby creating a thermal bridge in the structure.

The surfaces α , β , and γ are subject to convective heat flux. The ISO 10211:2017 standard specifies the values of the thermal resistance, R , which is related to the heat transfer coefficient, h , according to

$$h = \frac{1}{R}$$

Results and Discussion

Figure 2 shows the temperature profile. The heat losses are greater near the thermal bridge formed by the horizontal block that crosses the wall.

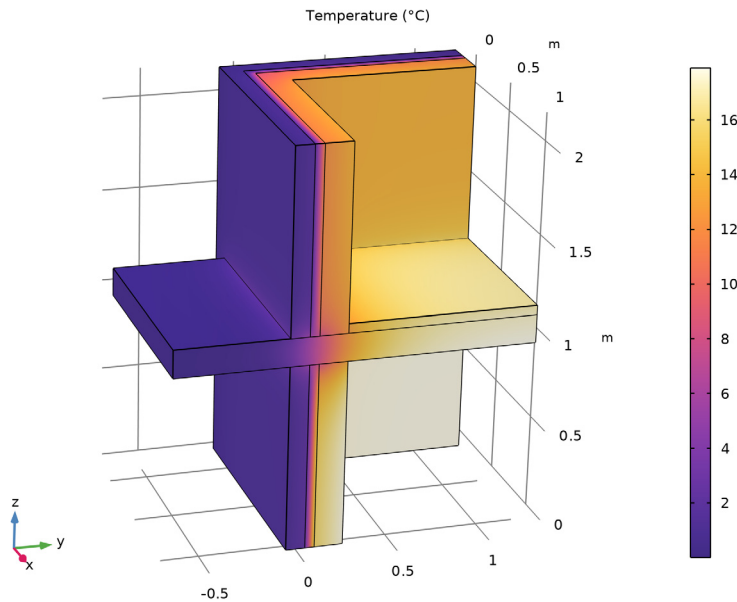

Figure 2: Temperature distribution of ISO 10211:2017 test case 3.

The numerical results of COMSOL Multiphysics are compared with the expected values provided by ISO 10211:2017 (Ref. 1) in Table 1.

TABLE 1: COMPARISON BETWEEN EXPECTED VALUES AND COMPUTED VALUES.

MEASURED QUANTITY	EXPECTED VALUES	COMPUTED VALUES	DIFFERENCE
Minimum temperature on α	11.32°C	11.32°C	<0.01°C
Minimum temperature on β	11.11°C	11.10°C	0.01°C
Heat flux through α	46.09 W	46.19 W	0.22%
Heat flux through β	13.89 W	13.92 W	0.25%
Heat flux through γ	59.98 W	60.12 W	0.23%

The maximum permissible differences to pass this test case are 0.1°C for temperature and 1% for heat flux. The measured values are completely consistent and meet the validation criteria. Note that they may change slightly depending on geometry representation and operating system.

As shown in Figure 3 and Figure 4, the minimum temperature of the surfaces α and β are located at their respective corners.

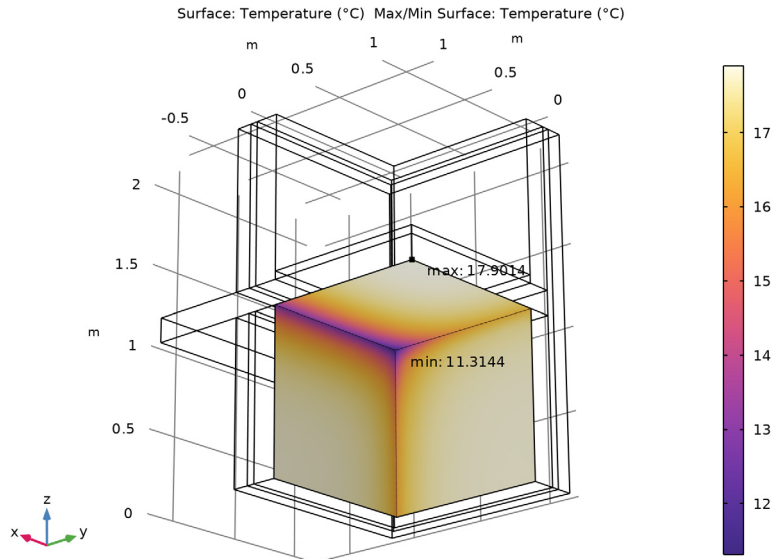

Figure 3: Minimum and maximum temperatures on surface α , ISO 10211:2017 test case 3.

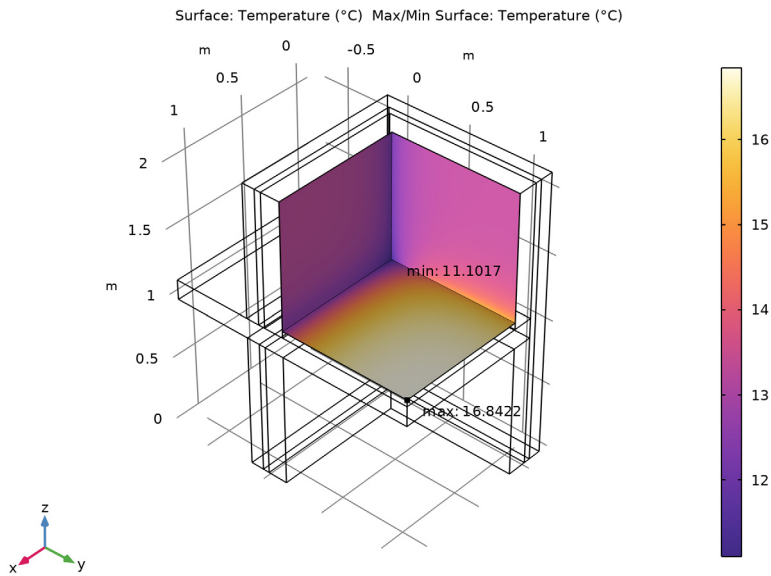

Figure 4: Minimum and maximum temperatures on surface β , ISO 10211:2017 test case 3.

Reference

1. European Committee for Standardization, *EN ISO 10211, Thermal bridges in building construction – Heat flows and surface temperatures – Detailed calculations (ISO 10211:2017)*, Appendix A, pp. 54–60, 2017.

Application Library path: Heat_Transfer_Module/
Buildings_and_Constructions/thermal_bridge_3d_two_floors



Modeling Instructions

From the **File** menu, choose **New**.

NEW

In the **New** window, click  **Model Wizard**.

MODEL WIZARD

- 1 In the **Model Wizard** window, click  **3D**.
- 2 In the **Select Physics** tree, select **Heat Transfer > Heat Transfer in Solids (ht)**.
- 3 Click **Add**.
- 4 Click  **Study**.
- 5 In the **Select Study** tree, select **General Studies > Stationary**.
- 6 Click  **Done**.

GLOBAL DEFINITIONS

Define the geometrical parameters.



Parameters I

- 1 In the **Model Builder** window, under **Global Definitions** click **Parameters I**.
- 2 In the **Settings** window for **Parameters**, locate the **Parameters** section.
- 3 In the table, enter the following settings:

Name	Expression	Value	Description
wall_t1	5[cm]	0.05 m	Insulation layer thickness
wall_t2	30[cm]	0.3 m	Wall thickness
rect1	1.2[m]	1.2 m	Wall first rectangle basis
rect2	1.3[m]	1.3 m	Wall second rectangle basis
rect_shift	-10[cm]	-0.1 m	Shift for the rectangles
wall_h	2.15[m]	2.15 m	Wall height
blk_w	1.15[m]	1.15 m	Rectangle horizontal block width
blk_d	1.9[m]	1.9 m	Rectangle horizontal block depth
blk_h	0.15[m]	0.15 m	Rectangle horizontal block height
blk_shiftx	5[cm]	0.05 m	Rectangle horizontal block x-shift
blk_shifty	-0.7[m]	-0.7 m	Rectangle horizontal block y-shift
blk_shiftz	1[m]	1 m	Rectangle horizontal block z-shift
sq_l	1[m]	1 m	Square horizontal block side length

Name	Expression	Value	Description
sq_h	5[cm]	0.05 m	Square horizontal block height
sq_shift	0.2[m]	0.2 m	Square horizontal block shift

Parameters - Physics

- 1 In the **Home** toolbar, click  **Parameters** and choose **Add > Parameters**.
- 2 In the **Settings** window for **Parameters**, type Parameters - Physics in the **Label** text field.
- 3 Locate the **Parameters** section. Click  **Load from File**.
- 4 Browse to the model's Application Libraries folder and double-click the file thermal_bridge_3d_two_floors_parameters.txt.

GEOMETRY I

To build the walls separating the external and internal surfaces, create the cross section geometry and extrude it.

Work Plane 1 (wp1)



- 1 In the **Geometry** toolbar, click  **Work Plane**.
- 2 In the **Settings** window for **Work Plane**, click  **Go to Plane Geometry**.

Work Plane 1 (wp1) > Plane Geometry



- 1 In the **Model Builder** window, click **Plane Geometry**.

The first two rectangles below correspond to the insulation layer of the wall.

Work Plane 1 (wp1) > Rectangle 1 (r1)



- 1 In the **Work Plane** toolbar, click  **Rectangle**.
- 2 In the **Settings** window for **Rectangle**, locate the **Size and Shape** section.
- 3 In the **Width** text field, type rect1.
- 4 In the **Height** text field, type wall_t1.
- 5 Click  **Build Selected**.

Work Plane 1 (wp1) > Rectangle 2 (r2)

- 1 In the **Work Plane** toolbar, click  **Rectangle**.
- 2 In the **Settings** window for **Rectangle**, locate the **Size and Shape** section.
- 3 In the **Width** text field, type wall_t1.
- 4 In the **Height** text field, type rect1.
- 5 Click  **Build Selected**.

6 Click the  **Zoom Extents** button in the **Graphics** toolbar.

Work Plane 1 (wp1) > Union 1 (uni1)

- 1 In the **Work Plane** toolbar, click  **Booleans and Partitions** and choose **Union**.
- 2 Click in the **Graphics** window and then press Ctrl+A to select both objects.
- 3 In the **Settings** window for **Union**, locate the **Union** section.
- 4 Clear the **Keep interior boundaries** checkbox.
- 5 Click  **Build Selected**.

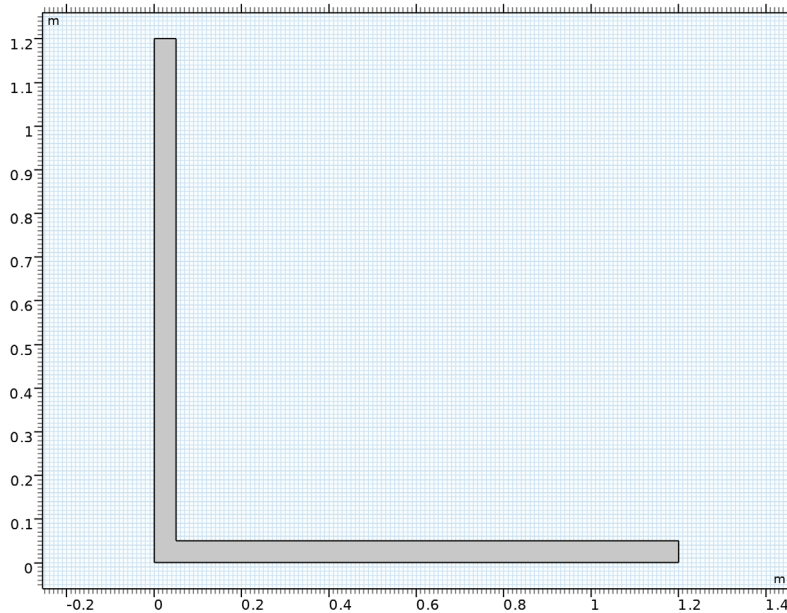

Work Plane 1 (wp1) > Plane Geometry

Build the remaining layers of the walls in a similar manner.

Work Plane 1 (wp1) > Rectangle 3 (r3)

- 1 In the **Work Plane** toolbar, click  **Rectangle**.
- 2 In the **Settings** window for **Rectangle**, locate the **Size and Shape** section.
- 3 In the **Width** text field, type rect2.
- 4 In the **Height** text field, type wall_t2.
- 5 Locate the **Position** section. In the **xw** text field, type rect_shift.
- 6 In the **yw** text field, type rect_shift.

7 Click  **Build Selected**.

Work Plane 1 (wp1) > Rectangle 4 (r4)

1 In the **Work Plane** toolbar, click  **Rectangle**.

2 In the **Settings** window for **Rectangle**, locate the **Size and Shape** section.

3 In the **Width** text field, type wall_t2.

4 In the **Height** text field, type rect2.

5 Locate the **Position** section. In the **xw** text field, type rect_shift.

6 In the **yw** text field, type rect_shift.

7 Click  **Build Selected**.

Work Plane 1 (wp1) > Union 2 (uni2)

1 In the **Work Plane** toolbar, click  **Booleans and Partitions** and choose **Union**.

2 Select the objects **r3** and **r4** only.

3 In the **Settings** window for **Union**, locate the **Union** section.

4 Clear the **Keep interior boundaries** checkbox.

5 Click  **Build Selected**.

Extrude 1 (ext1)

1 In the **Model Builder** window, right-click **Geometry 1** and choose **Extrude**.

2 In the **Settings** window for **Extrude**, locate the **Distances** section.

3 In the table, enter the following settings:

Distances (m)
wall_h

4 Click  **Build Selected**.

5 Click the  **Zoom Extents** button in the **Graphics** toolbar.

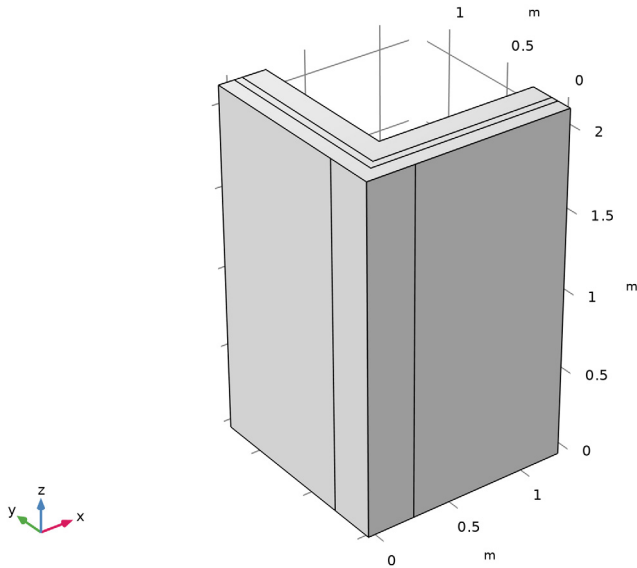

Block 1 (blk1)

1 In the **Geometry** toolbar, click  **Block**.

This block separates the two floors of the structure.

2 In the **Settings** window for **Block**, locate the **Size and Shape** section.

3 In the **Width** text field, type blk_w.

4 In the **Depth** text field, type blk_d.

5 In the **Height** text field, type blk_h.

6 Locate the **Position** section. In the **x** text field, type blk_shiftx.

7 In the **y** text field, type blk_shifty.

8 In the **z** text field, type blk_shiftz.



9 Click  **Build Selected**.

To avoid unnecessary edges, remove the intersection of the block with the walls. To do so, use the boolean operation **Difference** to subtract a copy of the block from the walls. Begin by creating the copy.



Block 2 (blk2)

Right-click **Block 1 (blk1)** and choose **Duplicate**.

Difference 1 (dif1)

- 1 In the **Geometry** toolbar, click  **Booleans and Partitions** and choose **Difference**.
- 2 Select the object **ext1** only.
The object labeled **ext1** is made up of the walls previously obtained by extrusion.
- 3 In the **Settings** window for **Difference**, locate the **Difference** section.
- 4 Click to select the  **Activate Selection** toggle button for **Objects to subtract**.
- 5 Select the object **blk1** only.
- 6 Click  **Build Selected**.

Block 3 (blk3)

- 1 In the **Geometry** toolbar, click  **Block**.
This block corresponds to the floor of the inside upper level.
- 2 In the **Settings** window for **Block**, locate the **Size and Shape** section.
- 3 In the **Width** text field, type `sq_1`.
- 4 In the **Depth** text field, type `sq_1`.
- 5 In the **Height** text field, type `sq_h`.
- 6 Locate the **Position** section. In the **x** text field, type `sq_shift`.
- 7 In the **y** text field, type `sq_shift`.
- 8 In the **z** text field, type `blk_shiftz+blk_h`.
- 9 Click  **Build Selected**.

Ignore Edges 1 (ige1)

- 1 In the **Geometry** toolbar, click  **Virtual Operations** and choose **Ignore Edges**.
In the first steps of the geometry sequence, six unused vertical edges were created on the walls. They are responsible for unnecessary constraints on the mesh and they generate extra boundaries by splitting some faces. For these reasons, follow the instructions below to remove them.
- 2 On the object **fin**, select Edges 6, 17, 33, 38, 60, and 63 only.
- 3 To reach the edges, click the **Wireframe Rendering** button in the **Graphics** toolbar. Note that you can make the selection by clicking the **Paste Selection** button and typing the indices in the dialog that opens.

- 4 In the **Settings** window for **Ignore Edges**, click  **Build Selected**.

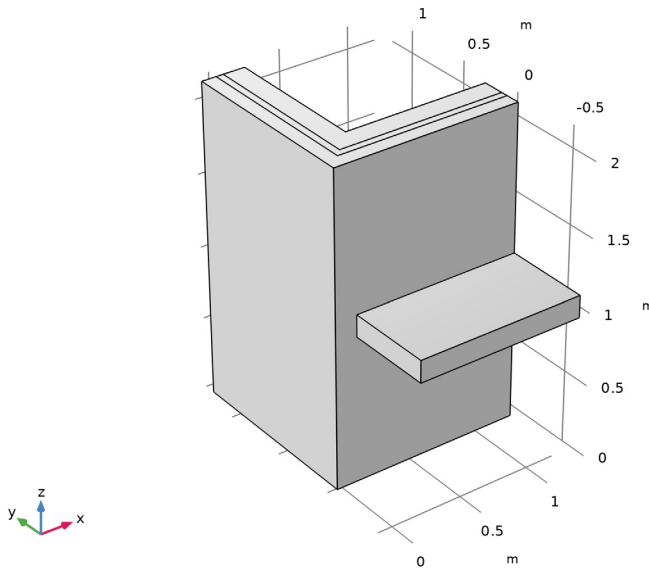

Interior wall

- 1 In the **Geometry** toolbar, click  **Selections** and choose **Explicit Selection**.
- 2 On the object **ige1**, select Domains 4 and 5 only.
- 3 In the **Settings** window for **Explicit Selection**, type Interior wall in the **Label** text field.

Isolation

- 1 In the **Geometry** toolbar, click  **Selections** and choose **Explicit Selection**.
- 2 On the object **ige1**, select Domain 2 only.
- 3 In the **Settings** window for **Explicit Selection**, type Isolation in the **Label** text field.

Exterior wall

- 1 In the **Geometry** toolbar, click  **Selections** and choose **Explicit Selection**.
- 2 In the **Settings** window for **Explicit Selection**, type Exterior wall in the **Label** text field.
- 3 On the object **ige1**, select Domain 1 only.

Horizontal Structure

- 1 In the **Geometry** toolbar, click  **Selections** and choose **Explicit Selection**.
- 2 In the **Settings** window for **Explicit Selection**, type Horizontal Structure in the **Label** text field.

3 On the object **ige1**, select Domain 3 only.

Floor

- 1 In the **Geometry** toolbar, click  **Selections** and choose **Explicit Selection**.
- 2 In the **Settings** window for **Explicit Selection**, type Floor in the **Label** text field.
- 3 On the object **ige1**, select Domain 6 only.

Alpha

- 1 In the **Geometry** toolbar, click  **Selections** and choose **Explicit Selection**.
- 2 In the **Settings** window for **Explicit Selection**, type Alpha in the **Label** text field.
- 3 Locate the **Entities to Select** section. From the **Geometric entity level** list, choose **Boundary**.
- 4 On the object **ige1**, select Boundaries 33–35 only.

Beta

- 1 In the **Geometry** toolbar, click  **Selections** and choose **Explicit Selection**.
- 2 In the **Settings** window for **Explicit Selection**, type Beta in the **Label** text field.
- 3 Locate the **Entities to Select** section. From the **Geometric entity level** list, choose **Boundary**.
- 4 On the object **ige1**, select Boundaries 39–41 only.

Gamma

- 1 In the **Geometry** toolbar, click  **Selections** and choose **Explicit Selection**.
- 2 In the **Settings** window for **Explicit Selection**, type Gamma in the **Label** text field.
- 3 Locate the **Entities to Select** section. From the **Geometric entity level** list, choose **Boundary**.
- 4 On the object **ige1**, select Boundaries 1, 2, and 11–14 only.

MATERIALS

Interior Wall

- 1 In the **Materials** toolbar, click  **Blank Material**.
- 2 In the **Settings** window for **Material**, type Interior Wall in the **Label** text field.
- 3 Locate the **Geometric Entity Selection** section. From the **Selection** list, choose **Interior wall**.

4 Locate the **Material Contents** section. In the table, enter the following settings:

Property	Variable	Value	Unit	Property group
Thermal conductivity	k_{iso} ; $k_{ii} = k_{iso}$, $k_{ij} = 0$	0.7 [W/ (m [*] K)]	W/(m·K)	Basic
Density	ρ	1700 [kg/ m ^{^3}]	kg/m ³	Basic
Heat capacity at constant pressure	C_p	800 [J/ (kg·K)]	J/(kg·K)	Basic

Isolation

- 1 In the **Materials** toolbar, click  **Blank Material**.
- 2 In the **Settings** window for **Material**, type Isolation in the **Label** text field.
- 3 Locate the **Geometric Entity Selection** section. From the **Selection** list, choose **Isolation**.
- 4 Locate the **Material Contents** section. In the table, enter the following settings:

Property	Variable	Value	Unit	Property group
Thermal conductivity	k_{iso} ; $k_{ii} = k_{iso}$, $k_{ij} = 0$	0.04 [W/ (m [*] K)]	W/(m·K)	Basic
Density	ρ	200 [kg/ m ^{^3}]	kg/m ³	Basic
Heat capacity at constant pressure	C_p	1000 [J/ (kg·K)]	J/(kg·K)	Basic

Exterior Wall

- 1 In the **Materials** toolbar, click  **Blank Material**.
- 2 In the **Settings** window for **Material**, type Exterior Wall in the **Label** text field.
- 3 Locate the **Geometric Entity Selection** section. From the **Selection** list, choose **Exterior wall**.
- 4 Locate the **Material Contents** section. In the table, enter the following settings:

Property	Variable	Value	Unit	Property group
Thermal conductivity	k_{iso} ; $k_{ii} = k_{iso}$, $k_{ij} = 0$	1 [W/ (m [*] K)]	W/(m·K)	Basic

Property	Variable	Value	Unit	Property group
Density	rho	2000 [kg / m ³]	kg/m ³	Basic
Heat capacity at constant pressure	Cp	1000 [J / (kg * K)]	J/(kg·K)	Basic

Horizontal Structure

- 1 In the **Materials** toolbar, click  **Blank Material**.
- 2 In the **Settings** window for **Material**, type Horizontal Structure in the **Label** text field.
- 3 Locate the **Geometric Entity Selection** section. From the **Selection** list, choose **Horizontal Structure**.
- 4 Locate the **Material Contents** section. In the table, enter the following settings:

Property	Variable	Value	Unit	Property group
Thermal conductivity	k_iso ; kii = k_iso, kij = 0	2.5 [W / (m * K)]	W/(m·K)	Basic
Density	rho	5000 [kg / m ³]	kg/m ³	Basic
Heat capacity at constant pressure	Cp	600 [J / (kg * K)]	J/(kg·K)	Basic

Floor

- 1 In the **Materials** toolbar, click  **Blank Material**.
- 2 In the **Settings** window for **Material**, type Floor in the **Label** text field.
- 3 Locate the **Geometric Entity Selection** section. From the **Selection** list, choose **Floor**.
- 4 Locate the **Material Contents** section. In the table, enter the following settings:

Property	Variable	Value	Unit	Property group
Thermal conductivity	k_iso ; kii = k_iso, kij = 0	1 [W / (m * K)]	W/(m·K)	Basic
Density	rho	1000 [kg / m ³]	kg/m ³	Basic
Heat capacity at constant pressure	Cp	800 [J / (kg * K)]	J/(kg·K)	Basic

HEAT TRANSFER IN SOLIDS (HT)

Heat Flux - Alpha

- 1 In the **Physics** toolbar, click  **Boundaries** and choose **Heat Flux**.
- 2 In the **Settings** window for **Heat Flux**, type Heat Flux - Alpha in the **Label** text field.
- 3 Locate the **Boundary Selection** section. From the **Selection** list, choose **Alpha**.
- 4 Locate the **Heat Flux** section. From the **Flux type** list, choose **Convective heat flux**.
- 5 In the h text field, type h_{alpha} .
- 6 In the T_{ext} text field, type T_{alpha} .

Heat Flux - Beta

- 1 In the **Physics** toolbar, click  **Boundaries** and choose **Heat Flux**.
- 2 In the **Settings** window for **Heat Flux**, type Heat Flux - Beta in the **Label** text field.
- 3 Locate the **Boundary Selection** section. From the **Selection** list, choose **Beta**.
- 4 Locate the **Heat Flux** section. From the **Flux type** list, choose **Convective heat flux**.
- 5 In the h text field, type h_{beta} .
- 6 In the T_{ext} text field, type T_{beta} .

Heat Flux - Gamma

- 1 In the **Physics** toolbar, click  **Boundaries** and choose **Heat Flux**.
- 2 Select Boundaries 1, 2, and 11–14 only.
- 3 In the **Settings** window for **Heat Flux**, type Heat Flux - Gamma in the **Label** text field.
- 4 Locate the **Boundary Selection** section. From the **Selection** list, choose **Gamma**.
- 5 Locate the **Heat Flux** section. From the **Flux type** list, choose **Convective heat flux**.
- 6 In the h text field, type h_{gamma} .
- 7 In the T_{ext} text field, type T_{gamma} .

MESH 1

- 1 In the **Model Builder** window, under **Component 1 (comp1)** click **Mesh 1**.
- 2 In the **Settings** window for **Mesh**, locate the **Physics-Controlled Mesh** section.
- 3 In the table, clear the **Use** checkbox for **Geometric Analysis, Detail Size**.
- 4 Click  **Build All**.



STUDY 1

In the **Study** toolbar, click  **Compute**.

RESULTS

Change the unit of the temperature results to degrees Celsius.

Preferred Units 1

- 1 In the **Results** toolbar, click  **Configurations** and choose **Preferred Units**.
- 2 In the **Settings** window for **Preferred Units**, locate the **Units** section.
- 3 Click  **Add Physical Quantity**.
- 4 In the **Physical Quantity** dialog, select **General > Temperature (K)** in the tree.
- 5 Click **OK**.
- 6 In the **Settings** window for **Preferred Units**, locate the **Units** section.
- 7 In the table, enter the following settings:

Quantity	Unit	Preferred unit
Temperature	K	°C

- 8 Click  **Apply**.

Temperature (ht)



The first plot group shows the temperature distribution; compare with [Figure 2](#).

Volume 1

- 1 In the **Model Builder** window, expand the **Temperature (ht)** node, then click **Volume 1**.
- 2 In the **Temperature (ht)** toolbar, click  **Plot**.

Follow the steps below to find the minimum temperatures on α and β as well as the heat fluxes through α , β , and γ .

Surface Minimum 1

- 1 In the **Results** toolbar, click  **More Derived Values** and choose **Minimum > Surface Minimum**.
- 2 In the **Settings** window for **Surface Minimum**, locate the **Selection** section.
- 3 From the **Selection** list, choose **Alpha**.
- 4 Click  **Evaluate**.

The displayed value should be close to 11.3°C.

Surface Minimum 2

- 1 In the **Results** toolbar, click  **More Derived Values** and choose **Minimum > Surface Minimum**.
- 2 In the **Settings** window for **Surface Minimum**, locate the **Selection** section.

3 From the **Selection** list, choose **Beta**.

4 Click **Evaluate**.

The displayed value should be close to 11.1°C.

Surface Integration 1

1 In the **Results** toolbar, click **More Derived Values** and choose **Integration > Surface Integration**.

2 In the **Settings** window for **Surface Integration**, locate the **Selection** section.

3 From the **Selection** list, choose **Alpha**.

4 Click **Replace Expression** in the upper-right corner of the **Expressions** section. From the menu, choose **Component 1 (comp1) > Heat Transfer in Solids > Boundary fluxes > ht.q0 - Inward heat flux - W/m²**.

5 Click **Evaluate**.

The displayed value should be close to 46.2 W.

Surface Integration 2

1 In the **Results** toolbar, click **More Derived Values** and choose **Integration > Surface Integration**.

2 In the **Settings** window for **Surface Integration**, locate the **Selection** section.

3 From the **Selection** list, choose **Beta**.

4 Click **Replace Expression** in the upper-right corner of the **Expressions** section. From the menu, choose **Component 1 (comp1) > Heat Transfer in Solids > Boundary fluxes > ht.q0 - Inward heat flux - W/m²**.

5 Click **Evaluate**.

The displayed value should be close to 13.9 W.

Surface Integration 3

1 In the **Results** toolbar, click **More Derived Values** and choose **Integration > Surface Integration**.

2 In the **Settings** window for **Surface Integration**, locate the **Selection** section.

3 From the **Selection** list, choose **Gamma**.

4 Click **Replace Expression** in the upper-right corner of the **Expressions** section. From the menu, choose **Component 1 (comp1) > Heat Transfer in Solids > Boundary fluxes > ht.q0 - Inward heat flux - W/m²**.

5 Click **Evaluate**.

TABLE 5

1 Go to the **Table 5** window.

The displayed value should be close to 60.1 W.

RESULTS

Temperature (ht)

To plot the location of the minimum temperature on α , follow the instructions below.

The resulting dataset is restricted to the surfaces α .

Minimum Temperature on Alpha

1 In the **Model Builder** window, expand the **Results > Datasets** node.

2 Right-click **Results** and choose **3D Plot Group**.

3 In the **Settings** window for **3D Plot Group**, type Minimum Temperature on Alpha in the **Label** text field.

4 Locate the **Plot Settings** section. From the **View** list, choose **New view**.

5 In the **Minimum Temperature on Alpha** toolbar, click  **Plot**.

This generates a dedicated view for the plot.

Surface 1

1 In the **Minimum Temperature on Alpha** toolbar, click  **Surface**.

2 In the **Settings** window for **Surface**, locate the **Coloring and Style** section.

3 From the **Color table** list, choose **HeatCameraLight**.

Selection 1

1 In the **Minimum Temperature on Alpha** toolbar, click  **Selection**.

2 In the **Settings** window for **Selection**, locate the **Selection** section.

3 From the **Selection** list, choose **Alpha**.

Minimum Temperature on Alpha

In the **Model Builder** window, under **Results** click **Minimum Temperature on Alpha**.

Max/Min Surface 1

In the **Minimum Temperature on Alpha** toolbar, click  **More Plots** and choose **Max/Min Surface**.

Selection 1

1 In the **Minimum Temperature on Alpha** toolbar, click  **Selection**.

2 In the **Settings** window for **Selection**, locate the **Selection** section.

3 From the **Selection** list, choose **Alpha**.

4 In the **Minimum Temperature on Alpha** toolbar, click  **Plot**.

As shown in [Figure 3](#), the minimum temperature is at the corner of α .

5 Click  **Plot**.

Now plot the location of the minimum temperature on β .

Minimum Temperature on Beta

1 Right-click **Minimum Temperature on Alpha** and choose **Duplicate**.

2 In the **Settings** window for **3D Plot Group**, type Minimum Temperature on Beta in the **Label** text field.

3 Locate the **Plot Settings** section. From the **View** list, choose **New view**.

4 In the **Minimum Temperature on Beta** toolbar, click  **Plot**.

5 In the **Model Builder** window, expand the **Minimum Temperature on Beta** node.

Selection 1

1 In the **Model Builder** window, expand the **Results > Minimum Temperature on Beta > Surface 1** node, then click **Selection 1**.

2 In the **Settings** window for **Selection**, locate the **Selection** section.

3 From the **Selection** list, choose **Beta**.

Selection 1

1 In the **Model Builder** window, expand the **Results > Minimum Temperature on Beta > Max/Min Surface 1** node, then click **Selection 1**.

2 In the **Settings** window for **Selection**, locate the **Selection** section.

3 From the **Selection** list, choose **Beta**.

4 In the **Minimum Temperature on Beta** toolbar, click  **Plot**.

5 Click the  **Zoom Extents** button in the **Graphics** toolbar.