



Model created in COMSOL Multiphysics 6.4

Thermomechanical Analysis of a Surface-Mounted Resistor

Introduction

The drive for miniaturizing electronic devices has resulted in today's extensive use of surface-mount electronic components. An important aspect in electronics design and the choice of materials is a product's durability and lifetime. For surface-mount resistors and other components producing heat it is a well-known problem that temperature cycling can lead to cracks propagating through the solder joints, resulting in premature failure ([Ref. 1](#)). For electronics in general there is a strong interest in changing the soldering material from lead- or tin-based solder alloys to other mixtures.

The following multiphysics example models the heat transport and structural stresses and deformations resulting from the temperature distribution using the Heat Transfer in Solids and Solid Mechanics interfaces.

Note: This model requires either the Structural Mechanics Module or the MEMS Module.

Model Definition

Figure 1 shows a photograph of a surface-mount resistor together with a diagram of it on a printed circuit board (PCB).

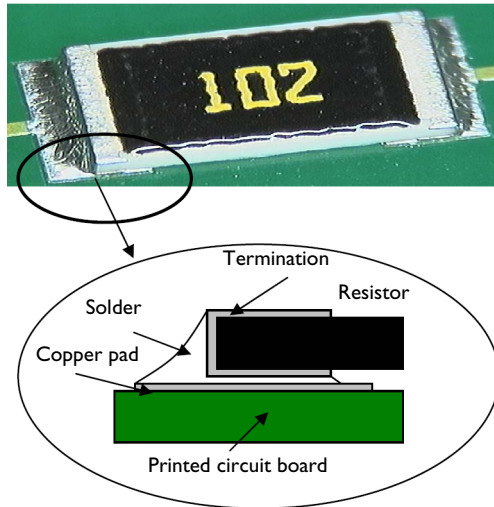

Figure 1: A photo and diagram of a typical surface-mounted resistor soldered to a PCB.

Table 1 shows the dimensions of the resistor and other key components in the model including the PCB.

TABLE 1: COMPONENT DIMENSIONS.

COMPONENT	LENGTH	WIDTH	HEIGHT
Resistor (Alumina)	6 mm	3 mm	0.5 mm
PCB (FR4)	16 mm	8 mm	1.6 mm
Cu pad	2 mm	3 mm	35 μm
Termination (Silver)	0.5 mm	3 mm	25 μm
Stand-off (gap to PCB)	-	-	105 μm

The simulation makes use of the symmetry so that it needs to include only half of the component (Figure 2). The modeling of the PCB is terminated a distance away from the resistor, in order to reduce effects of the boundary conditions.

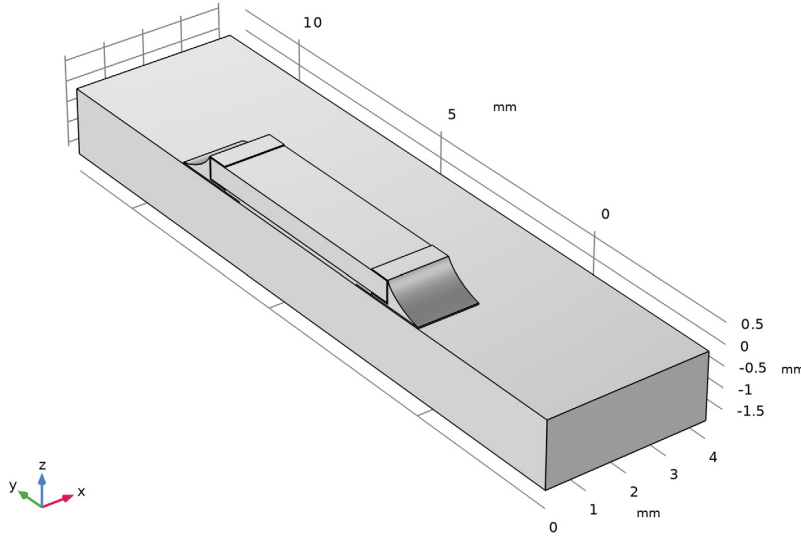

Figure 2: The simulation models only one half of the resistor.

In operation, the resistor dissipates 0.2 W of power as heat. Conduction to the PCB and convection to the surrounding air provide cooling. In this model, the heat transfer occurs through conduction in the subdomains. The model simplifies the surface cooling and describes it using a heat transfer coefficient, h , in this case set to $10 \text{ W}/(\text{m}^2 \cdot \text{K})$; the surrounding air temperature, T_{inf} , is at 300 K. The resulting heat transfer equation and boundary condition (included in the model using the Heat Transfer interface) are

$$\nabla \cdot (-k \nabla T) = Q$$

$$-\mathbf{n} \cdot (-k \nabla T) = h(T_{\text{inf}} - T)$$

where k is the thermal conductivity, and Q is the heating power per unit volume of the resistor (equal to $22.2 \text{ MW}/\text{m}^3$ corresponding to 0.2 W in total).

The model handles thermal expansion using a static structural analysis using the Structural Mechanics interface (a description of the corresponding equations is available in the *Structural Mechanics Module User's Guide*). The thermal and mechanical material

properties in this model are taken from the material library. The data for the solid materials, with the exception of Silver, are temperature independent, and the reference values are shown in the table below.

TABLE 2: MATERIAL PROPERTIES.

MATERIAL	E (GPa)	ν	α (ppm)	k (W/(m·K))	ρ (kg/m ³)	C_p (J/(kg·K))
Alumina	300	0.222	8.0	27	3900	900
Cu	110	0.35	17	400	8960	385
Fr4	22	0.15	18	0.3	1900	1369
60Sn-40Pb	10	0.4	21	50	9000	150

Air has temperature-dependent and pressure-dependent properties in the built-in material library. Because the temperature is a variable of the problem, it is automatically used. The pressure is by default set to 1 atm.

The stresses are zero at room temperature, 293 K. The boundary condition for the Solid Mechanics interface is that the cuts in the PCB do not rotate and have no net force normal to the cut.

Results and Discussion

The isosurfaces in [Figure 3](#) show the temperature distribution at steady state. The highest temperature occurs in the center of the resistor. The circuit board also heats up significantly.

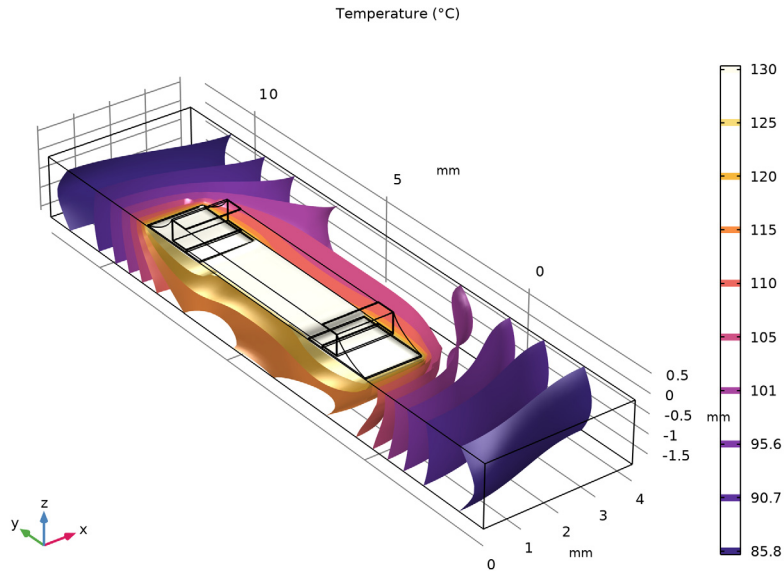

Figure 3: Temperature distribution in the resistor and the circuit board at steady state.

Thermal stresses appear as a result of the temperature increase; they arise from the materials' different expansion coefficients and from the bending of the PCB. [Figure 4](#) plots the equivalent stress (von Mises) together with the resulting deformation of the assembly.

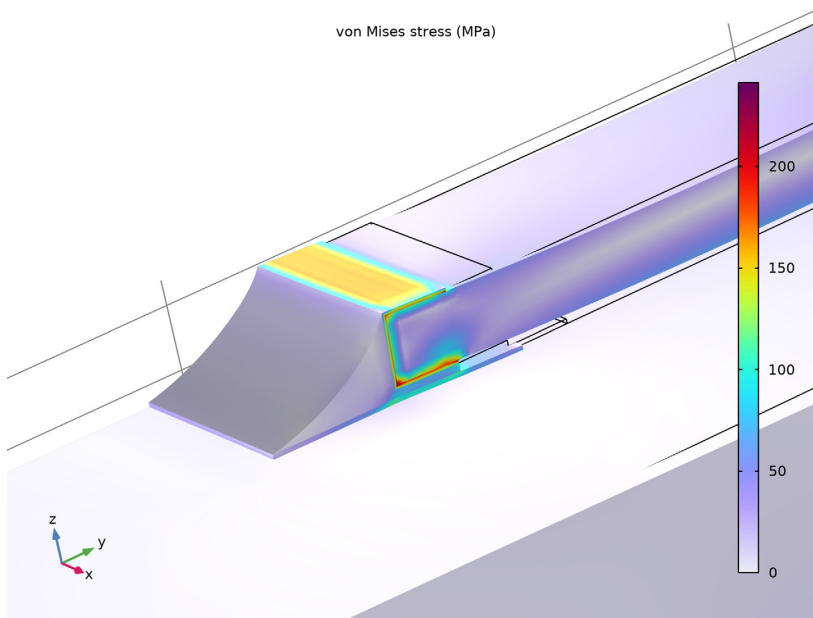

Figure 4: The thermally induced distribution of von Mises stress together with the deformation (magnified).

The highest stress seem to occur in the termination material. It is interesting to compare the equivalent stress to the yield stress and thereby investigate whether or not the material is irreversibly deformed. In that case the solder is the weak point. [Figure 5](#) shows the stress in the solder alone. The yield stress for solder is approximately 220 MPa. The highest stress in the solder is about 40 percent of this value. The structure does not get permanently deformed directly when heated. However, it is possible that the solder displays creep strains over time because of the combination of fairly high stress levels and elevated temperatures.

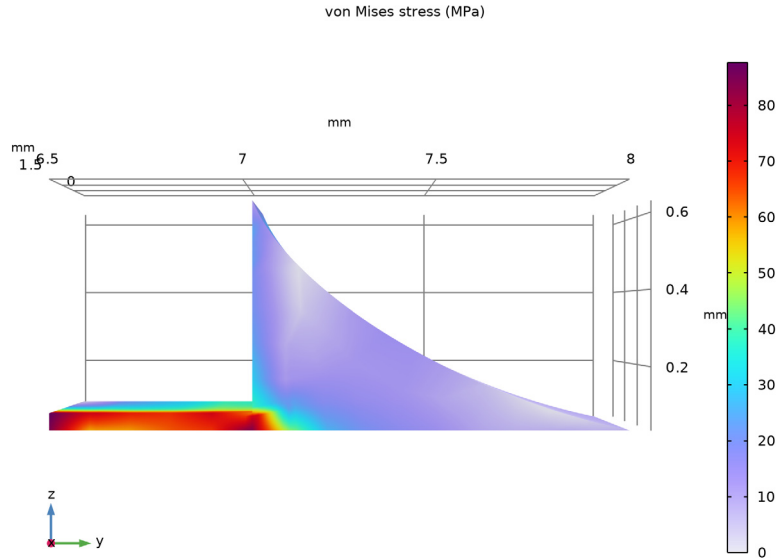

Figure 5: Close-up of the von Mises stress in the solder joints.

Notes About the COMSOL Implementation

In this example, the Thermal Stress interface automatically adds and couples the Solid Mechanics interface and the Heat Transfer interface. This is done by the predefined multiphysics coupling **Thermal Expansion**.

Build the geometry as an assembly of the bottom plate and the resistor to make it possible to mesh the parts independently. Use continuity conditions for the temperature and the displacements to connect the top and bottom parts of the geometry.

It is assumed that the temperature gradient in the normal direction on the cuts in the PCB is zero. The mechanical boundary conditions on the cuts must not impose a general state of compressive stress due to thermal expansion. At the same time, the restraint from the part of the PCB that is not modeled means that there is no rotation of the cross section. To obtain this effect, the entire cut must have the same (but unknown) displacement in the direction normal to the cut. This can be achieved by using a special setting in the **Symmetry** condition which allows a translation normal to the symmetry plane.

The heat transfer problem is nonlinear because the air has temperature-dependent properties, and is independent on the displacements. The structural problem, on the other hand, is linear but depends on the temperature. You can therefore solve the problem sequentially. Here this is done in a single study step by using a modified **Segregated solver**.

References

1. H. Lu, C. Bailey, M. Dusek, C. Hunt, and J. Nottay, “Modeling the Fatigue Life of Solder Joints of Surface Mount Resistors,” EMAP, 2000.
2. J.M. Coulson and J.F. Richardson, *Chemical Engineering*, vol. 1, Pergamon Press, appendix, 1990.

Application Library path: Heat_Transfer_Module/Thermal_Stress/
surface_resistor



Modeling Instructions

From the **File** menu, choose **New**.

NEW

In the **New** window, click  **Model Wizard**.

MODEL WIZARD

- 1 In the **Model Wizard** window, click  **3D**.
- 2 In the **Select Physics** tree, select **Structural Mechanics > Thermal–Structure Interaction > Thermal Stress, Solid**.
- 3 Click **Add**.
- 4 Click  **Study**.
- 5 In the **Select Study** tree, select **General Studies > Stationary**.
- 6 Click  **Done**.

GEOMETRY I

Insert the geometry sequence.

- 1 In the **Geometry** toolbar, click **Insert Sequence** and choose **Insert Sequence**.

- 2 Browse to the model's Application Libraries folder and double-click the file `surface_resistor_geom_sequence.mph`.
- 3 In the **Geometry** toolbar, click  **Build All**.

GLOBAL DEFINITIONS

Parameters I

- 1 In the **Model Builder** window, under **Global Definitions** click **Parameters I**.
- 2 In the **Settings** window for **Parameters**, locate the **Parameters** section.
- 3 In the table, enter the following settings:

Name	Expression	Value	Description
T_air	300[K]	300 K	Air temperature
h_air	10[W/(m ² *K)]	10 W/(m ² *K)	Heat transfer coefficient
Psouce	0.2[W]/2	0.1 W	Heat dissipated by the resistor on the half geometry
p0	1[atm]	1.0133E5 Pa	Air pressure
T0	80[degC]	353.15 K	Initial temperature guess

ADD MATERIAL

- 1 In the **Materials** toolbar, click  **Add Material** to open the **Add Material** window.
- 2 Go to the **Add Material** window.
- 3 In the tree, select **Built-in > FR4 (Circuit Board)**.
- 4 Click the **Add to Component** button in the window toolbar.
- 5 In the tree, select **Built-in > Alumina**.
- 6 Click the **Add to Component** button in the window toolbar.
- 7 In the tree, select **Built-in > Copper**.
- 8 Click the **Add to Component** button in the window toolbar.
- 9 In the tree, select **Material Library > Elements > Silver > Silver [solid] > Silver [solid, annealed]**.
- 10 Click the **Add to Component** button in the window toolbar.
- 11 In the tree, select **Built-in > Solder, 60Sn-40Pb**.
- 12 Click the **Add to Component** button in the window toolbar.
- 13 In the tree, select **Built-in > Air**.
- 14 Click the **Add to Component** button in the window toolbar.

15 In the **Materials** toolbar, click  **Add Material** to close the **Add Material** window.

MATERIALS

FR4 (Circuit Board) (mat1)

- 1 In the **Settings** window for **Material**, locate the **Geometric Entity Selection** section.
- 2 From the **Selection** list, choose **Manual**.
- 3 Click  **Clear Selection**.
- 4 Select Domain 1 only.

Alumina (mat2)

- 1 In the **Model Builder** window, click **Alumina (mat2)**.
- 2 Select Domain 5 only.

Copper (mat3)

- 1 In the **Model Builder** window, click **Copper (mat3)**.
- 2 Select Domains 2 and 7 only.

Silver [solid,annealed] (mat4)

- 1 In the **Model Builder** window, click **Silver [solid,annealed] (mat4)**.
- 2 Select Domains 4 and 9 only.

Solder, 60Sn-40Pb (mat5)

- 1 In the **Model Builder** window, click **Solder, 60Sn-40Pb (mat5)**.
- 2 Select Domains 3 and 8 only.

Air (mat6)

- 1 In the **Model Builder** window, click **Air (mat6)**.
- 2 Select Domain 6 only.

DEFINITIONS

Symmetry Plane

- 1 In the **Definitions** toolbar, click  **Box**.
- 2 In the **Settings** window for **Box**, type Symmetry Plane in the **Label** text field.
- 3 Locate the **Geometric Entity Level** section. From the **Level** list, choose **Boundary**.
- 4 Locate the **Box Limits** section. In the **x maximum** text field, type 0.1.
- 5 Locate the **Output Entities** section. From the **Include entity if** list, choose **Entity inside box**.

SOLID MECHANICS (SOLID)

- 1 In the **Model Builder** window, under **Component 1 (comp1)** click **Solid Mechanics (solid)**.
- 2 Select Domains 1–5 and 7–9 only.

Symmetry 1

- 1 In the **Physics** toolbar, click  **Boundaries** and choose **Symmetry**.
- 2 In the **Settings** window for **Symmetry**, locate the **Boundary Selection** section.
- 3 From the **Selection** list, choose **Symmetry Plane**.

Roller 1

- 1 In the **Physics** toolbar, click  **Boundaries** and choose **Roller**.
- 2 Select Boundary 8 only.

Symmetry 2

- 1 In the **Physics** toolbar, click  **Boundaries** and choose **Symmetry**.
- 2 Select Boundary 2 only.
- 3 In the **Settings** window for **Symmetry**, click to expand the **Normal Direction Condition** section.
- 4 From the list, choose **Free displacement**.

Symmetry 3

- 1 In the **Physics** toolbar, click  **Boundaries** and choose **Symmetry**.
- 2 Select Boundary 9 only.
- 3 In the **Settings** window for **Symmetry**, locate the **Normal Direction Condition** section.
- 4 From the list, choose **Free displacement**.

Prescribed Displacement 1

- 1 In the **Physics** toolbar, click  **Points** and choose **Prescribed Displacement**.
- 2 Select Point 1 only.
- 3 In the **Settings** window for **Prescribed Displacement**, locate the **Prescribed Displacement** section.
- 4 From the **Displacement in z direction** list, choose **Prescribed**.

HEAT TRANSFER IN SOLIDS (HT)

In the **Model Builder** window, under **Component 1 (comp1)** click **Heat Transfer in Solids (ht)**.

Fluid 1

- 1 In the **Physics** toolbar, click  **Domains** and choose **Fluid**.

2 Select Domain 6 only.

Heat Source I

1 In the **Physics** toolbar, click  **Domains** and choose **Heat Source**.

2 Select Domain 5 only.

3 In the **Settings** window for **Heat Source**, locate the **Heat Source** section.

4 From the **Heat source** list, choose **Heat rate**.

5 In the P_0 text field, type Psource.

Heat Flux I

1 In the **Physics** toolbar, click  **Boundaries** and choose **Heat Flux**.

2 Select Boundaries 3, 4, 11, 14, 15, 19, 29, 30, 44, 46, and 49–58 only.

3 In the **Settings** window for **Heat Flux**, locate the **Heat Flux** section.

4 From the **Flux type** list, choose **Convective heat flux**.

5 In the h text field, type h_air.

6 In the T_{ext} text field, type T_air.

Because the material properties are temperature dependent, the solution converges better if you supply an initial guess of the temperature.

Initial Values I

1 In the **Model Builder** window, click **Initial Values I**.

2 In the **Settings** window for **Initial Values**, locate the **Initial Values** section.

3 In the T text field, type T0.

MESH I

Mapped I

1 In the **Mesh** toolbar, click  **More Generators** and choose **Mapped**.

2 Select Boundaries 1, 10, 16, 20, 24, 33, 37, 40, 59, 61–63, 66, and 67 only.

Size I

1 Right-click **Mapped I** and choose **Size**.

2 Select Boundaries 10, 16, 20, 24, 33, 37, 40, 59, 61–63, 66, and 67 only.

3 In the **Settings** window for **Size**, locate the **Element Size** section.

4 Click the **Custom** button.

5 Locate the **Element Size Parameters** section.

6 Select the **Maximum element size** checkbox. In the associated text field, type 0.1.

Free Quad 1

- 1** In the **Mesh** toolbar, click  **More Generators** and choose **Free Quad**.
- 2** Select Boundaries 13 and 64 only.

Size 1

- 1** Right-click **Free Quad 1** and choose **Size**.
- 2** In the **Settings** window for **Size**, locate the **Element Size** section.
- 3** Click the **Custom** button.
- 4** Locate the **Element Size Parameters** section.
- 5** Select the **Maximum element size** checkbox. In the associated text field, type 0.1.

Swept 1

In the **Mesh** toolbar, click  **Swept**.

Size 1

- 1** Right-click **Swept 1** and choose **Size**.
- 2** In the **Settings** window for **Size**, locate the **Geometric Entity Selection** section.
- 3** From the **Geometric entity level** list, choose **Domain**.
- 4** Select Domains 2–16 only.
- 5** Locate the **Element Size** section. Click the **Custom** button.
- 6** Locate the **Element Size Parameters** section.
- 7** Select the **Maximum element size** checkbox. In the associated text field, type 0.2.

Size

- 1** In the **Model Builder** window, under **Component 1 (comp1) > Mesh 1** click **Size**.
- 2** In the **Settings** window for **Size**, locate the **Element Size** section.
- 3** From the **Predefined** list, choose **Extra fine**.

4 Click  **Build All**.

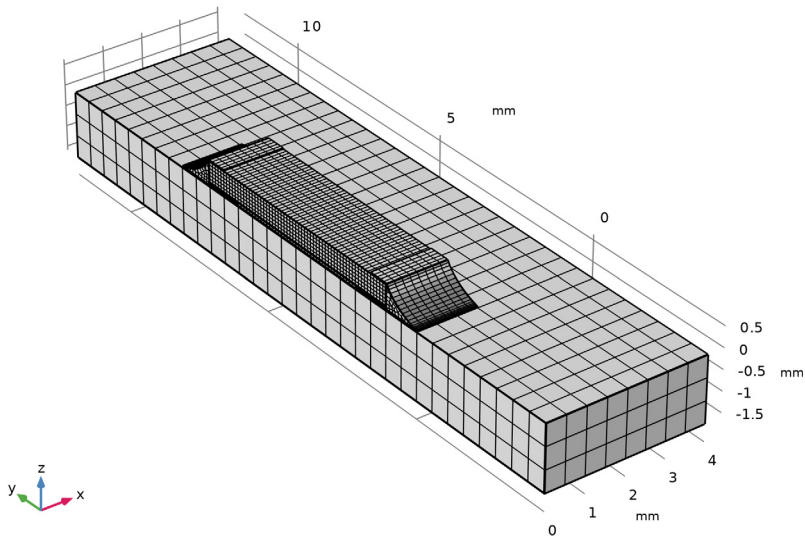

Because the heat transfer problem is independent of the displacements, the two fields can be solved to convergence in sequence with no outer iterations.

STUDY I

Solution 1 (sol1)

- 1 In the **Study** toolbar, click  **Show Default Solver**.
- 2 In the **Model Builder** window, expand the **Solution I (sol1)** node.
- 3 In the **Model Builder** window, expand the **Study I > Solver Configurations > Solution I (sol1) > Stationary Solver I** node, then click **Segregated I**.
- 4 In the **Settings** window for **Segregated**, locate the **General** section.
- 5 From the **Termination technique** list, choose **Iterations**.
- 6 In the **Model Builder** window, expand the **Study I > Solver Configurations > Solution I (sol1) > Stationary Solver I > Segregated I** node, then click **Temperature**.
- 7 In the **Settings** window for **Segregated Step**, click to expand the **Method and Termination** section.
- 8 From the **Termination technique** list, choose **Tolerance**.
- 9 In the **Tolerance factor** text field, type 1.

10 In the **Model Builder** window, under **Study 1 > Solver Configurations > Solution 1 (sol1) > Stationary Solver 1 > Segregated 1** click **Solid Mechanics**.

11 In the **Settings** window for **Segregated Step**, locate the **Method and Termination** section.

12 From the **Termination technique** list, choose **Tolerance**.

13 In the **Tolerance factor** text field, type 1.

14 In the **Study** toolbar, click  **Compute**.

Set default units for result presentation.

RESULTS

Preferred Units 1

1 In the **Results** toolbar, click  **Configurations** and choose **Preferred Units**.

2 In the **Settings** window for **Preferred Units**, locate the **Units** section.

3 Click  **Add Physical Quantity**.

4 In the **Physical Quantity** dialog, select **General > Temperature (K)** in the tree.

5 Click **OK**.

6 In the **Settings** window for **Preferred Units**, locate the **Units** section.

7 In the table, enter the following settings:

Quantity	Unit	Preferred unit
Temperature	K	°C

8 Click  **Add Physical Quantity**.

9 In the **Physical Quantity** dialog, select **Solid Mechanics > Stress tensor (N/m²)** in the tree.

10 Click **OK**.

11 In the **Settings** window for **Preferred Units**, locate the **Units** section.

12 In the table, enter the following settings:

Quantity	Unit	Preferred unit
Stress tensor	N/m ²	MPa

13 Click  **Apply**.

Volume 1

Hold down the left mouse button and drag in the **Graphics** window to rotate the geometry so that you see the opposite side of the resistor, which is where the largest stresses occur,

as shown in [Figure 4](#). Similarly, use the right mouse button to translate the geometry and the middle button to zoom.

Now, study the stresses in the solder.

- 1 From the **Results** menu, choose **Result Templates**.

RESULT TEMPLATES



- 1 Go to the **Result Templates** window.
- 2 In the tree, select **Study 1/Solution 1 (sol1) > Heat Transfer in Solids > Isothermal Contours (ht)**.
- 3 Click the **Add Result Template** button in the window toolbar.
- 4 From the **Results** menu, choose **Result Templates**.

RESULTS

Isothermal Contours (ht)

In the **Model Builder** window, expand the **Stress (solid)** node.

Isosurface 1

- 1 Click the  **Zoom Extents** button in the **Graphics** toolbar.
- 2 Click the  **Go to Default View** button in the **Graphics** toolbar.

Stress in Solder Joint

- 1 In the **Model Builder** window, expand the **Isothermal Contours (ht)** node.
- 2 Right-click **Results** and choose **3D Plot Group**.
- 3 In the **Settings** window for **3D Plot Group**, type **Stress in Solder Joint** in the **Label** text field.
- 4 Locate the **Plot Settings** section. Clear the **Plot dataset edges** checkbox.



Volume 1

- 1 Right-click **Stress in Solder Joint** and choose **Volume**.
- 2 In the **Settings** window for **Volume**, click **Replace Expression** in the upper-right corner of the **Expression** section. From the menu, choose **Component 1 (comp1) > Solid Mechanics > Stress > solid.misesGp - von Mises stress - N/m²**.
- 3 Locate the **Coloring and Style** section. From the **Color table** list, choose **Prism**.

Selection 1

- 1 Right-click **Volume 1** and choose **Selection**.
- 2 Select Domain 8 only.

Stress in Solder Joint

- 1 In the **Model Builder** window, under **Results** click **Stress in Solder Joint**.
- 2 In the **Stress in Solder Joint** toolbar, click  **Plot**.
- 3 Click the  **Go to YZ View** button in the **Graphics** toolbar.

Compare the resulting plot with that in [Figure 5](#).

Temperature (ht)

The second default plot group shows the temperature on the modeled geometry's surface.

- 1 Click the  **Go to Default View** button in the **Graphics** toolbar.
- 2 In the **Model Builder** window, click **Temperature (ht)**.

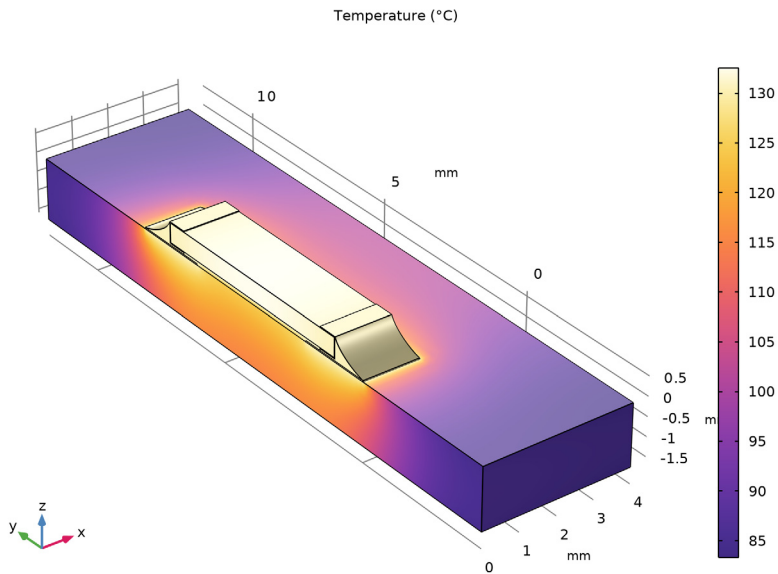

Isothermal Contours (ht)

The third default plot shows the isosurfaces ([Figure 3](#)).