



Model created in COMSOL Multiphysics 6.4

Lumped Composite Thermal Barrier with Shells

Introduction

This example shows how to replace two 3D finite element domains by thin structures for heat transfer modeling, and to connect them through a lumped thermal system to account for a thermal barrier.

The model is a variant of the [Composite Thermal Barrier](#) and [Lumped Composite Thermal Barrier](#) models, in which two ceramic thin layers with different thermal conductivities are sandwiched in a steel column.

Three modeling approaches are compared for the computation of the temperature distribution through the whole column. First, both the steel column and the composite (made of the ceramic layers) are modeled as 3D objects. In the second approach, to avoid resolving both the column and the ceramic layers in the geometry, the Heat Transfer in Shells interface is used to model the upper and lower parts of the steel column, and the Lumped Thermal System interface is used for the ceramic layers, and coupled to the two shells through boundary conditions. Finally, the equivalent lumped system is simulated with a single resistor carrying the equivalent thermal resistance of the ceramic layers. In case of such simple lumped thermal system, it can be entirely encapsulated in the **Thermal Connection, Interface-Interface** feature, the Lumped Thermal System physics interface is then not required.

This methodology is useful when modeling heat transfer through thermal barriers like multilayer coatings.

GEOMETRY

This tutorial uses a simple geometry as shown in [Figure 1](#). The cylinder has a radius of 2 cm and a height of 4 cm.

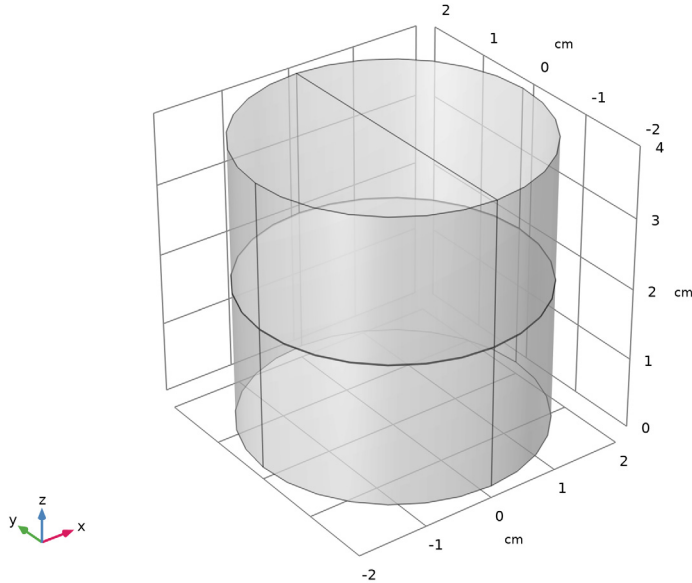

Figure 1: Geometry.

The composite consists of two layers with different thermal conductivities. The first approach resolves each layer as a 3D domain. The height of the layers is about three orders of magnitude smaller than the bulk height. This often requires to build a mesh manually to accurately resolve the thin structure.

THIN STRUCTURE REPRESENTATION OF THE STEEL COLUMN

The Heat Transfer in Shells interface is used to model the conductive heat transfer in the top and bottom parts of the steel column.

The top and bottom cylinders are represented by two circular shells whose thickness is defined in the **Layered Material** settings. Although the column thickness is not represented explicitly in the geometry, the Layered Material technology allows to solve the temperature distribution through the shells. The number of implicit mesh elements can be

set in the **Layered Material** node as well, to fit the settings used for the swept meshes of the 3D domains.

The **Temperature, Interface** condition is applied on the bottom interface of the lower part of the column, and on the top interface of the upper part of the column, to prescribe the temperature at each extremity of the column.

NETWORK REPRESENTATION OF THE THERMAL BARRIER

COMSOL Multiphysics provides the Lumped Thermal System physics interface, available from the Heat Transfer Module, and in which the **Conductive Thermal Resistor** feature allows to model conductive heat transfer without representing the underlying geometry.

The Lumped Thermal System physics interface uses a network representation of thermal systems to model heat transfer by analogy with electrical circuits. The domain and boundary conditions for heat transfer are idealized by components joined by a network of perfectly thermally conductive wires.

This 0D approach simplifies the geometry and thus the mesh. In complex geometries, this lumped approach can significantly reduce the amount of memory and time required for the simulation.

For the modeling of the thermally resistive ceramic layers, two **Conductive Thermal Resistor** components are connected in a serial circuit.

The coupling between the two physics interfaces, Heat Transfer in Shells (2D approach) and Lumped Thermal System (0D approach), is performed through the following features:

- **Thermal Connection, Interface-Interface** feature in the Heat Transfer in Shells interface, applied on the bottom interface of the top shell, and on the top interface of the bottom shell. This feature uses the heat rate defined by each **External Terminal** feature to set a heat flux on the corresponding boundary in the distributed finite element model.
- **External Terminal** feature in the Lumped Thermal System interface, applied at each extremity of the thermal circuit. This feature prescribes the temperature T_{ext} provided by the **Thermal Connection, Interface-Interface** feature of the Heat Transfer in Shells interface.

The complete thermal circuit modeled by the Lumped Thermal System interface is as shown in [Figure 2](#).

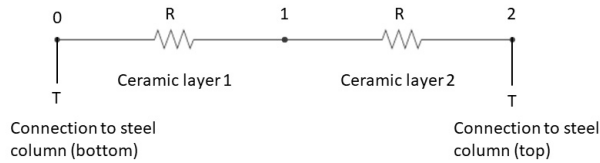

Figure 2: Thermal circuit for heat transfer in the ceramic layers.

CONDUCTIVE THERMAL RESISTOR

The **Conductive Thermal Resistor** feature models heat conduction in a thin shell of constant conductivity. In this example, a plane shell configuration is assumed, and the thermal resistance R (SI unit: K/W) of each layer is expressed from the thermal conductivity k (SI unit: W/(m·K)), the thickness L (SI unit: m), and the surface area A (SI unit: m²) as follows:

$$R = \frac{L}{kA}$$

It then assumes that the heat rate P (SI unit: W) through each layer is proportional to the temperature difference ΔT (SI unit: K) across it:

$$P = \frac{\Delta T}{R}$$

See *Theory for the Lumped Thermal System Interface* in the *Heat Transfer Module User's Guide* for more details about the underlying theory.

In case of a lumped thermal system consisting of two serially connected resistors as presented in [Figure 2](#), the total thermal resistance can be defined as the sum of the two resistances:

$$R_{tot} = R_1 + R_2$$

Such simple lumped systems can be directly encapsulated in the **Thermal Connection, Interface-Interface** feature of the Heat Transfer in Shells interface. In that case, the Lumped Thermal System physics interface is not required. This approach is demonstrated as well in the present tutorial.

MATERIAL PROPERTIES

The cylinder is made of steel. The composite consists of two layers of different ceramics.

TABLE I: CERAMICS MATERIAL PROPERTIES.

PROPERTY	CERAMIC 1	CERAMIC 2
Thermal conductivity	1 W/(m·K)	0.5 W/(m·K)
Density	6000 kg/m ³	5800 kg/m ³
Heat capacity at constant pressure	320 J/(kg·K)	280 J/(kg·K)

BOUNDARY CONDITIONS

The temperature at the bottom is fixed to 20°C whereas one half of the top boundary is held at 1220°C (1493 K). All other outer boundaries are perfectly insulated.

Results and Discussion

Figure 3 shows the temperature distribution in the cylinder. The composite acts as a thermal barrier resulting in a jump of the temperature over the layer.

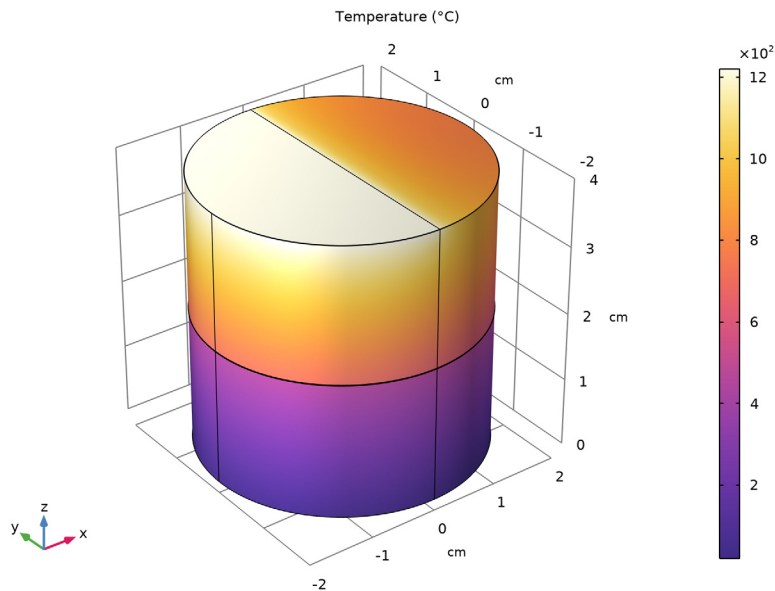

Figure 3: Temperature distribution.

Of interest is if the lumped approach (using Heat Transfer in Shells and Lumped Thermal System) produces reliable results compared to resolving the whole steel column in 3D. This can be done with a comparative line graph as in Figure 4. Using the lumped approaches accurate results for the bulk temperatures are obtained.

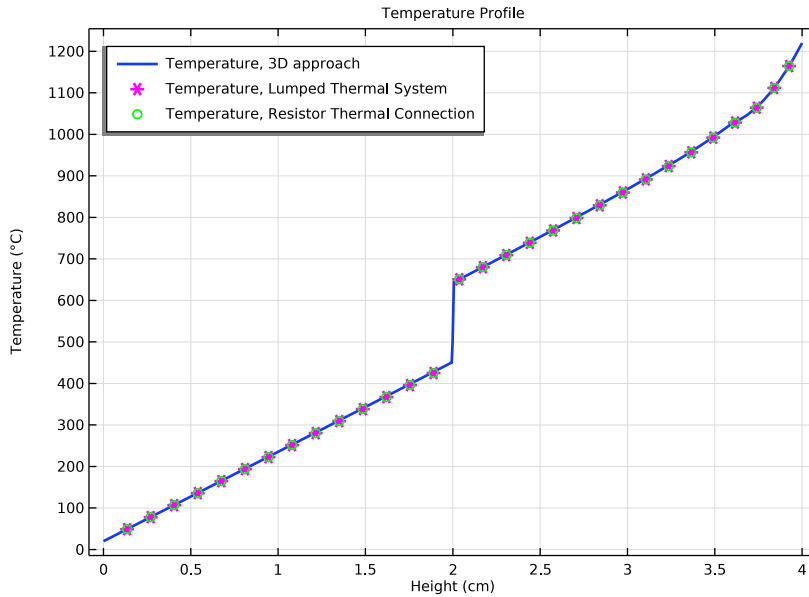

Figure 4: Temperature profile for 3D and lumped approaches.

Another important question for simulating is the influence on the mesh size and on the required RAM.

With the default tetrahedral mesh of the 3D model, the number of mesh elements is about 130,000 elements and the meshing algorithm gives some warnings.

With the swept mesh feature you can significantly reduce the number of elements to about 2800 elements (prisms), which is only 2% of the initial number of elements. Note that in complex geometries the swept mesh algorithm is often not applicable.

Using the lumped approach, the number of mesh elements reduces to about 1300 elements (triangles). You can see the number of mesh elements used in the **Messages** window below the **Graphics** window.

Notes About the COMSOL Implementation

To compare the results directly, three approaches are handled in a single MPH file.

Application Library path: Heat_Transfer_Module/Tutorials,_Thin_Structure/
lumped_composite_thermal_barrier_shells



Modeling Instructions

From the **File** menu, choose **New**.

NEW

In the **New** window, click  **Model Wizard**.

MODEL WIZARD

- 1 In the **Model Wizard** window, click  **3D**.
- 2 In the **Select Physics** tree, select **Heat Transfer > Heat Transfer in Solids (ht)**.
- 3 Click **Add**.
- 4 Click  **Study**.
- 5 In the **Select Study** tree, select **General Studies > Stationary**.
- 6 Click  **Done**.

GLOBAL DEFINITIONS

Parameters 1

- 1 In the **Model Builder** window, under **Global Definitions** click **Parameters 1**.
- 2 In the **Settings** window for **Parameters**, locate the **Parameters** section.
- 3 In the table, enter the following settings:



Name	Expression	Value	Description
d_ceram1	50[um]	5E-5 m	Thickness of layer 1
d_ceram2	75[um]	7.5E-5 m	Thickness of layer 2
k_ceram1	1[W/(m*K)]	1 W/(m·K)	Thermal conductivity of layer 1

Name	Expression	Value	Description
k_ceram2	0.5[W/(m*K)]	0.5 W/(m·K)	Thermal conductivity of layer 2
T_hot	1220[degC]	1493.2 K	Hot temperature

GEOMETRY I



- 1 In the **Model Builder** window, under **Component 1 (comp1)** click **Geometry 1**.
- 2 In the **Settings** window for **Geometry**, locate the **Units** section.
- 3 From the **Length unit** list, choose **cm**.

Cylinder 1 (cyl1)



- 1 In the **Geometry** toolbar, click  **Cylinder**.
- 2 In the **Settings** window for **Cylinder**, locate the **Size and Shape** section.
- 3 In the **Radius** text field, type 2.
- 4 In the **Height** text field, type 4.
- 5 In the **Geometry** toolbar, click  **Build All**.

Now, create thin cylinders to define the ceramic layers between the two steel domains.

Cylinder 2 (cyl2)

- 1 In the **Geometry** toolbar, click  **Cylinder**.
- 2 In the **Settings** window for **Cylinder**, locate the **Size and Shape** section.
- 3 In the **Radius** text field, type 2.
- 4 In the **Height** text field, type d_ceram1.
- 5 Locate the **Position** section. In the **z** text field, type 2 - (d_ceram1+d_ceram2) / 2.
- 6 In the **Geometry** toolbar, click  **Build All**.



Cylinder 3 (cyl3)

- 1 In the **Geometry** toolbar, click  **Cylinder**.
- 2 In the **Settings** window for **Cylinder**, locate the **Size and Shape** section.
- 3 In the **Radius** text field, type 2.
- 4 In the **Height** text field, type d_ceram2.
- 5 Locate the **Position** section. In the **z** text field, type 2 - (d_ceram1+d_ceram2) / 2 + d_ceram1.
- 6 In the **Geometry** toolbar, click  **Build All**.

Polygon 1 (pol1)

- 1 In the **Geometry** toolbar, click  **More Primitives** and choose **Polygon**.
- 2 In the **Settings** window for **Polygon**, locate the **Coordinates** section.
- 3 In the table, enter the following settings:

x (cm)	y (cm)	z (cm)
0	-2	4
0	2	4

- 4 In the **Geometry** toolbar, click  **Build All**.
- 5 Click the  **Zoom Extents** button in the **Graphics** toolbar.

MATERIALS

Material Link 1 (matlnk1)



- 1 In the **Model Builder** window, under **Component 1 (comp1)** right-click **Materials** and choose **More Materials > Material Link**.
- 2 In the **Settings** window for **Material Link**, locate the **Link Settings** section.
- 3 Click  **Add Material from Library**.

ADD MATERIAL TO MATERIAL LINK 1 (MATLNK1)

- 1 Go to the **Add Material to Material Link 1 (matlnk1)** window.
- 2 In the tree, select **Built-in > Steel AISI 4340**.
- 3 Right-click and choose **Add Material**.

MATERIALS

Material Link 2 (matlnk2)

- 1 Right-click **Materials** and choose **More Materials > Material Link**.
- 2 In the **Settings** window for **Material Link**, locate the **Geometric Entity Selection** section.
- 3 Click  **Paste Selection**.
- 4 In the **Paste Selection** dialog, type 2 in the **Selection** text field.
- 5 Click **OK**.
- 6 In the **Settings** window for **Material Link**, locate the **Link Settings** section.
- 7 Click  **Blank Material**.
- 8 In the **Model Builder** window, click **Material Link 2 (matlnk2)**.
- 9 Click  **Go to Material**.

GLOBAL DEFINITIONS



Ceramic 1

- 1 In the **Model Builder** window, under **Global Definitions > Materials** click **Material 2 (mat2)**.
- 2 In the **Settings** window for **Material**, type Ceramic 1 in the **Label** text field.
- 3 Locate the **Material Contents** section. In the table, enter the following settings:

Property	Variable	Value	Unit	Property group
Thermal conductivity	k_{iso} ; $k_{ii} = k_{iso}$, $k_{ij} = 0$	k_ceram1	W/(m·K)	Basic
Density	rho	6000 [kg/m ³]	kg/m ³	Basic
Heat capacity at constant pressure	Cp	320 [J/(kg·K)]	J/(kg·K)	Basic

MATERIALS

Material Link 3 (matlnk3)

- 1 In the **Model Builder** window, under **Component 1 (comp1)** right-click **Materials** and choose **More Materials > Material Link**.
- 2 In the **Settings** window for **Material Link**, locate the **Geometric Entity Selection** section.
- 3 Click  **Paste Selection**.
- 4 In the **Paste Selection** dialog, type 3 in the **Selection** text field.
- 5 Click **OK**.
- 6 In the **Settings** window for **Material Link**, locate the **Link Settings** section.
- 7 Click  **Blank Material**.
- 8 In the **Model Builder** window, click **Material Link 3 (matlnk3)**.
- 9 Click  **Go to Material**.

GLOBAL DEFINITIONS

Ceramic 2

- 1 In the **Model Builder** window, under **Global Definitions > Materials** click **Material 3 (mat3)**.
- 2 In the **Settings** window for **Material**, type Ceramic 2 in the **Label** text field.

3 Locate the **Material Contents** section. In the table, enter the following settings:

Property	Variable	Value	Unit	Property group
Thermal conductivity	k_{iso} ; $k_{ij} = k_{iso}$, $k_{ij} = 0$	k_ceram2	W/(m·K)	Basic
Density	rho	5800 [kg/m ³]	kg/m ³	Basic
Heat capacity at constant pressure	Cp	280 [J/(kg·K)]	J/(kg·K)	Basic

HEAT TRANSFER IN SOLIDS (HT)

Temperature 1

1 In the **Physics** toolbar, click  **Boundaries** and choose **Temperature**.

2 Select Boundary 3 only.

Temperature 2

1 In the **Physics** toolbar, click  **Boundaries** and choose **Temperature**.

2 Select Boundary 13 only.

3 In the **Settings** window for **Temperature**, locate the **Temperature** section.

4 In the T_0 text field, type T_{hot} .

MESH 1

First, mesh the top surface with a free triangular mesh and extrude it in layers through the cylindrical geometry. With a **Distribution** node, specify how many mesh layers are to be created within the domain. Resolve the composite layers with two elements in thickness.

Free Triangular 1

1 In the **Mesh** toolbar, click  **More Generators** and choose **Free Triangular**.

2 Select Boundaries 13 and 18 only.

3 In the **Settings** window for **Free Triangular**, click  **Build Selected**.

Swept 1

In the **Mesh** toolbar, click  **Swept**.

Distribution 1

1 Right-click **Swept 1** and choose **Distribution**.

2 Select Domains 2 and 3 only.

3 In the **Settings** window for **Distribution**, locate the **Distribution** section.

- 4 In the **Number of elements** text field, type 2.
- 5 Click  **Build All**.



STUDY I: 3D APPROACH

- 1 In the **Model Builder** window, right-click **Study I** and choose **Rename**.
- 2 In the **Rename Study** dialog, type Study 1: 3D Approach in the **New label** text field.
- 3 Click **OK**.
- 4 In the **Study** toolbar, click  **Compute**.

RESULTS

Change the unit of the temperature results to degrees Celsius.

Preferred Units I

- 1 In the **Results** toolbar, click  **Configurations** and choose **Preferred Units**.
- 2 In the **Settings** window for **Preferred Units**, locate the **Units** section.
- 3 Click  **Add Physical Quantity**.
- 4 In the **Physical Quantity** dialog, select **General > Temperature (K)** in the tree.
- 5 Click **OK**.
- 6 In the **Settings** window for **Preferred Units**, locate the **Units** section.
- 7 In the table, enter the following settings:

Quantity	Unit	Preferred unit
Temperature	K	°C

- 8 Click  **Apply**.

Temperature, 3D Approach

The following plot is produced by default: temperature profile on the volume as in [Figure 3](#).

- 1 In the **Model Builder** window, under **Results** click **Temperature (ht)**.
- 2 In the **Settings** window for **3D Plot Group**, type Temperature, 3D Approach in the **Label** text field.

Create now the second model which uses the **Heat Transfer in Shells** and **Lumped Thermal System** interfaces and compare the results to the first approach.

ADD COMPONENT

In the **Model Builder** window, right-click the root node and choose **Add Component > 3D**.

GEOMETRY 2

Work Plane 1 (wp1)

- 1 In the **Geometry** toolbar, click  **Work Plane**.
- 2 In the **Settings** window for **Geometry**, locate the **Units** section.
- 3 From the **Length unit** list, choose **cm**.

Work Plane 1 (wp1) > Plane Geometry

In the **Model Builder** window, click **Plane Geometry**.

Work Plane 1 (wp1) > Circle 1 (c1)

- 1 In the **Work Plane** toolbar, click  **Circle**.
- 2 In the **Settings** window for **Circle**, locate the **Size and Shape** section.
- 3 In the **Radius** text field, type 2.

Work Plane 2 (wp2)

- 1 In the **Model Builder** window, right-click **Geometry 2** and choose **Work Plane**.
- 2 In the **Settings** window for **Work Plane**, locate the **Plane Definition** section.
- 3 In the **z-coordinate** text field, type $2+(d_ceram1+d_ceram2)/2$.

Work Plane 2 (wp2) > Plane Geometry

In the **Model Builder** window, click **Plane Geometry**.



Work Plane 2 (wp2) > Circle 1 (c1)

- 1 In the **Work Plane** toolbar, click  **Circle**.
- 2 In the **Settings** window for **Circle**, locate the **Size and Shape** section.
- 3 In the **Radius** text field, type 2.

Polygon 1 (pol1)

- 1 In the **Model Builder** window, right-click **Geometry 2** and choose **More Primitives > Polygon**.
- 2 In the **Settings** window for **Polygon**, locate the **Coordinates** section.
- 3 In the table, enter the following settings:

x (cm)	y (cm)	z (cm)
0	-2	$2+(d_ceram1+d_ceram2)/2$
0	2	$2+(d_ceram1+d_ceram2)/2$

- 4 Click  **Build All Objects**.
- 5 Click the  **Zoom Extents** button in the **Graphics** toolbar.

MATERIALS

Layered Material Link 1 (lmat1)

- 1 In the **Model Builder** window, under **Component 2 (comp2)** right-click **Materials** and choose **Layers > Layered Material Link**.
- 2 In the **Settings** window for **Layered Material Link**, locate the **Layered Material Settings** section.
- 3 Click **+ Add Layered Material**.

GLOBAL DEFINITIONS

Layered Material 1 (lmat1)

- 1 In the **Model Builder** window, under **Global Definitions > Materials** click **Layered Material 1 (lmat1)**.
- 2 In the **Settings** window for **Layered Material**, locate the **Layer Definition** section.
- 3 In the table, enter the following settings:

Layer	Material	Rotation	Value	Thickness	Mesh elements
Layer 1	Steel AISI 4340 (mat1)	0.0	0 rad	2[cm] - (d_ceram1 + d_ceram2) / 2	2

MATERIALS

Layered Material Link 1 (lmat1)

- 1 In the **Model Builder** window, under **Component 2 (comp2) > Materials** click **Layered Material Link 1 (lmat1)**.
- 2 In the **Settings** window for **Layered Material Link**, click **Section_bar** in the upper-right corner of the **Layered Material Settings** section. From the menu, choose **Layer Cross-Section Preview**.
- 3 Locate the **Orientation and Position** section. From the **Position** list, choose **Bottom side on boundary**.

GLOBAL DEFINITIONS



Layered Material 1 (lmat1)

- 1 In the **Model Builder** window, under **Global Definitions > Materials** click **Layered Material 1 (lmat1)**.
- 2 In the **Settings** window for **Layered Material**, locate the **Layer Definition** section.

3 In the table, enter the following settings:

Layer	Material	Rotation	Value	Thickness	Mesh elements
Layer 1	Steel AISI 4340 (mat1)	0.0	0 rad	2 [cm] - (d_ceram1+d_ceram2) / 2	5

ADD PHYSICS

- 1 In the **Home** toolbar, click  **Add Physics** to open the **Add Physics** window.
- 2 Go to the **Add Physics** window.
- 3 In the tree, select **Heat Transfer > Thin Structures > Heat Transfer in Shells (htlsh)**.
- 4 Find the **Physics interfaces in study** subsection. In the table, clear the **Solve** checkbox for **Study 1: 3D Approach**.
- 5 Click the **Add to Component 2** button in the window toolbar.
- 6 In the tree, select **Heat Transfer > Lumped Thermal System (lts)**.
- 7 In the table, clear the **Solve** checkbox for **Study 1: 3D Approach**.
- 8 Click the **Add to Component 2** button in the window toolbar.
- 9 In the **Home** toolbar, click  **Add Physics** to close the **Add Physics** window.

LUMPED THERMAL SYSTEM (LTS)

Ceramic 1

- 1 In the **Physics** toolbar, click  **Global** and choose **Conductive Thermal Resistor**.
- 2 In the **Settings** window for **Conductive Thermal Resistor**, type Ceramic 1 in the **Label** text field.
- 3 Locate the **Component Parameters** section. From the **Specify** list, choose **Thermal and geometric properties**.
- 4 From the **Material** list, choose **Ceramic 1 (mat2)**.
- 5 In the **A** text field, type $\pi \cdot (2[\text{cm}])^2$.
- 6 In the **L** text field, type d_ceram1.

Ceramic 2

- 1 In the **Physics** toolbar, click  **Global** and choose **Conductive Thermal Resistor**.
- 2 In the **Settings** window for **Conductive Thermal Resistor**, type Ceramic 2 in the **Label** text field.

3 Locate the **Node Connections** section. In the table, enter the following settings:

Label	Node names
p1	1
p2	2

4 Locate the **Component Parameters** section. From the **Specify** list, choose **Thermal and geometric properties**.

5 From the **Material** list, choose **Ceramic 2 (mat3)**.

6 In the *A* text field, type $\pi \cdot (2[\text{cm}])^2$.

7 In the *L* text field, type *d_ceram2*.

External Terminal 1 (term1)

1 In the **Physics** toolbar, click  **Global** and choose **External Terminal**.

2 In the **Settings** window for **External Terminal**, locate the **Node Connections** section.

3 In the **Node name** text field, type 0.

External Terminal 2 (term2)

1 In the **Physics** toolbar, click  **Global** and choose **External Terminal**.

2 In the **Settings** window for **External Terminal**, locate the **Node Connections** section.

3 In the **Node name** text field, type 2.

HEAT TRANSFER IN SHELLS (HTLSH)

Solid 1

1 In the **Model Builder** window, under **Component 2 (comp2)** > **Heat Transfer in Shells (htlsh)** click **Solid 1**.

2 In the **Settings** window for **Solid**, locate the **Layer Model** section.

3 From the **Layer type** list, choose **General**.

Add **Thermal Connection, Interface-Interface** feature on top and bottom boundaries of the composite barrier to connect the **External Terminal** features added previously.

Thermal Connection, Interface-Interface 1

1 In the **Physics** toolbar, click  **Global** and choose **Thermal Connection, Interface-Interface**.

2 In the **Settings** window for **Thermal Connection, Interface-Interface**, locate the **Shell Properties** section.

3 From the **Layered material for connector 1** list, choose **Layered Material Link 1 (llmat1)**.

- 4 From the **Layered material for connector 2** list, choose **Layered Material Link 1 (lmat1)**.
- 5 Select Boundary 1 only.
- 6 Locate the **Boundary Selection, Connector 2** section. Click to select the  **Activate Selection** toggle button.
- 7 Select Boundaries 2 and 3 only.
- 8 Locate the **Interface Selection** section. From the **Connector 2, apply to** list, choose **Bottom interface**.
- 9 Locate the **Thermal Connection** section. From the **Connection type** list, choose **Lumped thermal system**.
- 10 Find the **Connector 2** subsection. From the $P_{\text{ext},2}$ list, choose **External Terminal 2 (term2) (Its/term2)**.

Temperature, Interface 1

- 1 In the **Physics** toolbar, click  **Boundaries** and choose **Temperature, Interface**.
- 2 Select Boundary 1 only.
- 3 In the **Settings** window for **Temperature, Interface**, locate the **Interface Selection** section.
- 4 From the **Apply to** list, choose **Bottom interface**.

Temperature, Interface 2

- 1 In the **Physics** toolbar, click  **Boundaries** and choose **Temperature, Interface**.
- 2 Select Boundary 2 only.
- 3 In the **Settings** window for **Temperature, Interface**, locate the **Interface Selection** section.
- 4 From the **Apply to** list, choose **Top interface**.
- 5 Locate the **Temperature** section. In the T_0 text field, type T_hot.

MESH 2

- 1 In the **Model Builder** window, under **Component 2 (comp2)** click **Mesh 2**.
- 2 In the **Settings** window for **Mesh**, locate the **Physics-Controlled Mesh** section.
- 3 In the table, clear the **Use** checkbox for **Geometric Analysis, Detail Size**.

ADD STUDY

- 1 In the **Home** toolbar, click  **Add Study** to open the **Add Study** window.
- 2 Go to the **Add Study** window.
- 3 Find the **Studies** subsection. In the **Select Study** tree, select **General Studies > Stationary**.
- 4 Click the **Add Study** button in the window toolbar.

5 In the **Home** toolbar, click  **Add Study** to close the **Add Study** window.

STUDY 2

Step 1: Stationary

- 1 In the **Settings** window for **Stationary**, locate the **Physics and Variables Selection** section.
- 2 In the **Solve** column of the table, under **Component 1 (comp1)**, clear the checkbox for **Heat Transfer in Solids (ht)**.
- 3 In the **Model Builder** window, right-click **Study 2** and choose **Rename**.
- 4 In the **Rename Study** dialog, type Study 2: Lumped Thermal System Approach in the **New label** text field.
- 5 Click **OK**.
- 6 In the **Study** toolbar, click  **Compute**.

RESULTS

Temperature, Lumped Thermal System Approach

In the **Settings** window for **3D Plot Group**, type Temperature, Lumped Thermal System Approach in the **Label** text field.

Volume 1

- 1 In the **Model Builder** window, expand the **Temperature, Lumped Thermal System Approach** node, then click **Volume 1**.
- 2 In the **Settings** window for **Volume**, locate the **Expression** section.
- 3 From the **Unit** list, choose **°C**.
- 4 Click the  **Zoom Extents** button in the **Graphics** toolbar.

Create now the third model which represents a simplified version of the second model. It simulates the same lumped thermal system but with one single resistor of resistance R_{tot} previously defined. Such simple systems with one single resistor can be defined directly in **Thermal Connection, Interface-Interface** boundary feature. Create this model and compare the results to the previous approaches.

ADD COMPONENT

In the **Model Builder** window, right-click the root node and choose **Add Component > 3D**.

GEOMETRY 3

Work Plane 1 (wp1)

- 1 In the **Geometry** toolbar, click  **Work Plane**.
- 2 In the **Settings** window for **Geometry**, locate the **Units** section.
- 3 From the **Length unit** list, choose **cm**.

Work Plane 1 (wp1) > Plane Geometry

In the **Model Builder** window, click **Plane Geometry**.

Work Plane 1 (wp1) > Circle 1 (c1)

- 1 In the **Work Plane** toolbar, click  **Circle**.
- 2 In the **Settings** window for **Circle**, locate the **Size and Shape** section.
- 3 In the **Radius** text field, type 2.

Work Plane 2 (wp2)

- 1 In the **Model Builder** window, right-click **Geometry 3** and choose **Work Plane**.
- 2 In the **Settings** window for **Work Plane**, locate the **Plane Definition** section.
- 3 In the **z-coordinate** text field, type $2+(d_ceram1+d_ceram2)/2$.

Work Plane 2 (wp2) > Plane Geometry

In the **Model Builder** window, click **Plane Geometry**.



Work Plane 2 (wp2) > Circle 1 (c1)

- 1 In the **Work Plane** toolbar, click  **Circle**.
- 2 In the **Settings** window for **Circle**, locate the **Size and Shape** section.
- 3 In the **Radius** text field, type 2.

Polygon 1 (pol1)

- 1 In the **Model Builder** window, right-click **Geometry 3** and choose **More Primitives > Polygon**.
- 2 In the **Settings** window for **Polygon**, locate the **Coordinates** section.
- 3 In the table, enter the following settings:

x (cm)	y (cm)	z (cm)
0	-2	$2+(d_ceram1+d_ceram2)/2$
0	2	$2+(d_ceram1+d_ceram2)/2$



- 4 Click  **Build All Objects**.
- 5 Click the  **Zoom Extents** button in the **Graphics** toolbar.

MATERIALS

Layered Material Link 2 (lmat2)

- 1 In the **Model Builder** window, under **Component 3 (comp3)** right-click **Materials** and choose **Layers > Layered Material Link**.
- 2 In the **Settings** window for **Layered Material Link**, locate the **Orientation and Position** section.
- 3 From the **Position** list, choose **Bottom side on boundary**.

ADD PHYSICS

- 1 In the **Home** toolbar, click  **Add Physics** to open the **Add Physics** window.
- 2 Go to the **Add Physics** window.
- 3 In the tree, select **Heat Transfer > Thin Structures > Heat Transfer in Shells (htlsh)**.
- 4 Find the **Physics interfaces in study** subsection. In the table, clear the **Solve** checkboxes for **Study 1: 3D Approach** and **Study 2: Lumped Thermal System Approach**.
- 5 Click the **Add to Component 3** button in the window toolbar.
- 6 In the **Home** toolbar, click  **Add Physics** to close the **Add Physics** window.

HEAT TRANSFER IN SHELLS 2 (HTLSH2)

Solid 1

- 1 In the **Settings** window for **Solid**, locate the **Layer Model** section.
- 2 From the **Layer type** list, choose **General**.



Temperature, Interface 1

- 1 In the **Physics** toolbar, click  **Boundaries** and choose **Temperature, Interface**.
- 2 Select Boundary 1 only.
- 3 In the **Settings** window for **Temperature, Interface**, locate the **Interface Selection** section.
- 4 From the **Apply to** list, choose **Bottom interface**.

Temperature, Interface 2

- 1 In the **Physics** toolbar, click  **Boundaries** and choose **Temperature, Interface**.
- 2 Select Boundary 2 only.
- 3 In the **Settings** window for **Temperature, Interface**, locate the **Interface Selection** section.
- 4 From the **Apply to** list, choose **Top interface**.
- 5 Locate the **Temperature** section. In the T_0 text field, type T_hot.



Thermal Connection, Interface–Interface 1

- 1 In the **Physics** toolbar, click  **Global** and choose **Thermal Connection, Interface–Interface**.
- 2 In the **Settings** window for **Thermal Connection, Interface–Interface**, locate the **Shell Properties** section.
- 3 From the **Layered material for connector 1** list, choose **Layered Material Link 2 (llmat2)**.
- 4 From the **Layered material for connector 2** list, choose **Layered Material Link 2 (llmat2)**.
- 5 Select Boundary 1 only.
- 6 Locate the **Boundary Selection, Connector 2** section. Click to select the  **Activate Selection** toggle button.
- 7 Select Boundaries 2 and 3 only.
- 8 Locate the **Interface Selection** section. From the **Connector 2, apply to** list, choose **Bottom interface**.
- 9 Locate the **Thermal Connection** section. In the R text field, type $(d_ceram1/k_ceram1+d_ceram2/k_ceram2)/(pi*(2[cm])^2)$.

MESH 3

- 1 In the **Model Builder** window, under **Component 3 (comp3)** click **Mesh 3**.
- 2 In the **Settings** window for **Mesh**, locate the **Physics-Controlled Mesh** section.
- 3 In the table, clear the **Use** checkbox for **Geometric Analysis, Detail Size**.
- 4 Click  **Build All**.

ADD STUDY

- 1 In the **Home** toolbar, click  **Add Study** to open the **Add Study** window.
- 2 Go to the **Add Study** window.
- 3 Find the **Studies** subsection. In the **Select Study** tree, select **General Studies > Stationary**.
- 4 Click the **Add Study** button in the window toolbar.
- 5 In the **Home** toolbar, click  **Add Study** to close the **Add Study** window.

STUDY 3: RESISTOR THERMAL CONNECTION APPROACH

- 1 In the **Model Builder** window, right-click **Study 3** and choose **Rename**.
- 2 In the **Rename Study** dialog, type Study 3: Resistor Thermal Connection Approach in the **New label** text field.
- 3 Click **OK**.

Step 1: Stationary

- 1 In the **Model Builder** window, under **Study 3: Resistor Thermal Connection Approach** click **Step 1: Stationary**.
- 2 In the **Settings** window for **Stationary**, locate the **Physics and Variables Selection** section.
- 3 In the **Solve for** column of the table, clear the checkboxes for **Component 1 (comp1)** and **Component 2 (comp2)**.
- 4 In the **Study** toolbar, click  **Compute**.

RESULTS

Temperature, Resistor Thermal Connection Approach

In the **Settings** window for **3D Plot Group**, type Temperature, Resistor Thermal Connection Approach in the **Label** text field.

Volume 1

- 1 In the **Model Builder** window, expand the **Temperature, Resistor Thermal Connection Approach** node, then click **Volume 1**.
- 2 In the **Settings** window for **Volume**, locate the **Expression** section.
- 3 From the **Unit** list, choose °C.
- 4 Click the  **Zoom Extents** button in the **Graphics** toolbar.

Now, create temperature profiles along the height of the cylinder for all three approaches.

Temperature Profiles

- 1 In the **Results** toolbar, click  **ID Plot Group**.
- 2 In the **Settings** window for **ID Plot Group**, type Temperature Profiles in the **Label** text field.
- 3 Locate the **Plot Settings** section.
- 4 Select the **x-axis label** checkbox. In the associated text field, type Height (cm).
- 5 Select the **Flip the x- and y-axes** checkbox.
- 6 Click to expand the **Title** section. From the **Title type** list, choose **Manual**.
- 7 In the **Title** text area, type Temperature Profiles.
- 8 Locate the **Legend** section. From the **Position** list, choose **Upper left**.
- 9 In the **Maximum relative width** text field, type 0.6.

Line Graph 1

- 1 Right-click **Temperature Profiles** and choose **Line Graph**.

- 2 Select Edges 15, 17, 19, and 21 only.
- 3 In the **Settings** window for **Line Graph**, locate the **y-Axis Data** section.
- 4 In the **Expression** text field, type z.
- 5 Locate the **x-Axis Data** section. From the **Parameter** list, choose **Expression**.
- 6 Click to expand the **Coloring and Style** section. From the **Width** list, choose **2**.
- 7 Click to expand the **Legends** section. From the **Legends** list, choose **Manual**.
- 8 Select the **Show legends** checkbox.
- 9 In the table, enter the following settings:

Legends

Temperature, 3D approach

Temperature Profiles

In the **Model Builder** window, click **Temperature Profiles**.

Through Thickness 1

- 1 In the **Temperature Profiles** toolbar, click  **More Plots** and choose **Through Thickness**.
- 2 In the **Settings** window for **Through Thickness**, locate the **Data** section.
- 3 From the **Dataset** list, choose **Study 2: Lumped Thermal System Approach/ Solution 2 (3) (sol2)**.
- 4 Select Point 3 only.
- 5 Locate the **x-Axis Data** section. In the **Expression** text field, type T2.
- 6 Locate the **y-Axis Data** section. From the **Parameter** list, choose **Expression**.
- 7 In the **Expression** text field, type `l1mat1.th`.
- 8 Click to expand the **Coloring and Style** section. Find the **Line style** subsection. From the **Line** list, choose **None**.
- 9 From the **Color** list, choose **Red**.
- 10 Find the **Line markers** subsection. From the **Marker** list, choose **Asterisk**.
- 11 From the **Positioning** list, choose **Interpolated**.
- 12 Set the **Number** value to **15**.
- 13 Click to expand the **Legends** section. Select the **Show legends** checkbox.
- 14 From the **Legends** list, choose **Manual**.

15 In the table, enter the following settings:



Legends

Temperature, Lumped Thermal System

Temperature Profiles

In the **Model Builder** window, click **Temperature Profiles**.

Through Thickness 2

- 1 In the **Temperature Profiles** toolbar, click  **More Plots** and choose **Through Thickness**.
- 2 In the **Settings** window for **Through Thickness**, locate the **Data** section.
- 3 From the **Dataset** list, choose **Study 2: Lumped Thermal System Approach/ Solution 2 (3) (sol2)**.
- 4 Select Point 4 only.
- 5 Locate the **x-Axis Data** section. In the **Expression** text field, type T2.
- 6 Locate the **y-Axis Data** section. From the **Parameter** list, choose **Expression**.
- 7 In the **Expression** text field, type $l1mat1.th + 2[cm]$.
- 8 Locate the **Coloring and Style** section. Find the **Line style** subsection. From the **Line** list, choose **None**.
- 9 From the **Color** list, choose **Red**.
- 10 Find the **Line markers** subsection. From the **Marker** list, choose **Asterisk**.
- 11 From the **Positioning** list, choose **Interpolated**.
- 12 Set the **Number** value to **15**.
- 13 In the **Temperature Profiles** toolbar, click  **Plot**.

Temperature Profiles

In the **Model Builder** window, click **Temperature Profiles**.

Through Thickness 3

- 1 In the **Temperature Profiles** toolbar, click  **More Plots** and choose **Through Thickness**.
- 2 In the **Settings** window for **Through Thickness**, locate the **Data** section.
- 3 From the **Dataset** list, choose **Study 3: Resistor Thermal Connection Approach/ Solution 3 (6) (sol3)**.
- 4 Select Point 3 only.
- 5 Locate the **x-Axis Data** section. In the **Expression** text field, type T3.
- 6 Locate the **y-Axis Data** section. From the **Parameter** list, choose **Expression**.

- 7 In the **Expression** text field, type `l1mat2.th`.
- 8 Locate the **Coloring and Style** section. Find the **Line style** subsection. From the **Line** list, choose **None**.
- 9 From the **Color** list, choose **Green**.
- 10 Find the **Line markers** subsection. From the **Marker** list, choose **Circle**.
- 11 From the **Positioning** list, choose **Interpolated**.
- 12 Set the **Number** value to **15**.
- 13 Locate the **Legends** section. Select the **Show legends** checkbox.
- 14 From the **Legends** list, choose **Manual**.
- 15 In the table, enter the following settings:



Legends

Temperature, Resistor Thermal Connection

Temperature Profiles

In the **Model Builder** window, click **Temperature Profiles**.

Through Thickness 4

- 1 In the **Temperature Profiles** toolbar, click  **More Plots** and choose **Through Thickness**.
- 2 In the **Settings** window for **Through Thickness**, locate the **Data** section.
- 3 From the **Dataset** list, choose **Study 3: Resistor Thermal Connection Approach/ Solution 3 (6) (sol3)**.
- 4 Select Point 4 only.
- 5 Locate the **x-Axis Data** section. In the **Expression** text field, type `T3`.
- 6 Locate the **y-Axis Data** section. From the **Parameter** list, choose **Expression**.
- 7 In the **Expression** text field, type `l1mat2.th + 2[cm]`.
- 8 Locate the **Coloring and Style** section. Find the **Line style** subsection. From the **Line** list, choose **None**.
- 9 From the **Color** list, choose **Green**.
- 10 Find the **Line markers** subsection. From the **Marker** list, choose **Circle**.
- 11 From the **Positioning** list, choose **Interpolated**.
- 12 Set the **Number** value to **15**.
- 13 In the **Temperature Profiles** toolbar, click  **Plot**.

Temperature, 3D Approach

In the **Model Builder** window, under **Results** click **Temperature, 3D Approach**.

