



Model created in COMSOL Multiphysics 6.4

Lumped Composite Thermal Barrier

Introduction

This example shows how to connect two 3D finite element domains through a Thermal Lumped System for heat transfer modeling.

The model is a variant of the [Composite Thermal Barrier](#) model, in which two ceramic thin layers with different thermal conductivities are sandwiched in a steel column.

Three modeling approaches are compared for the computation of the temperature distribution through the whole column. First, the composite (made of the ceramic layers) is modeled as a 3D object. In the second approach, to avoid resolving the thin domains, the Lumped Thermal System physics interface is used and coupled to the remaining domains through boundary conditions. Finally, the equivalent lumped system is simulated with a single resistor carrying the equivalent thermal resistance of the ceramic layers. In case of such simple lumped thermal system, it can be entirely encapsulated in the **Thermal Connection** feature, the Lumped Thermal System physics interface is then not required.

The methodology is useful when modeling heat transfer through thermal barriers like multilayer coatings.

GEOMETRY

This tutorial uses a simple geometry as shown in [Figure 1](#). The cylinder has a radius of 2 cm and a height of 4 cm.

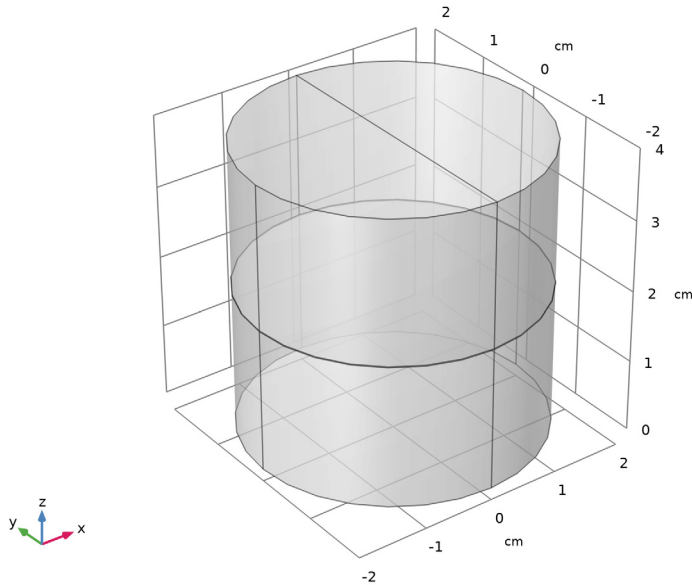

Figure 1: Geometry.

The composite consists of two layers with different thermal conductivities. The first approach resolves each layer as a 3D domain. The height of the layers is about three orders of magnitude smaller than the bulk height. This often requires to build a mesh manually to accurately resolve the thin structure.

NETWORK REPRESENTATION OF THE THERMAL SYSTEM

COMSOL Multiphysics provides the Lumped Thermal System physics interface, available from the Heat Transfer Module, and in which the **Conductive Thermal Resistor** feature allows to model conductive heat transfer without representing the underlying geometry.

The Lumped Thermal System physics interface uses a network representation of thermal systems to model heat transfer by analogy with electrical circuits. The domain and

boundary conditions for heat transfer are idealized by components joined by a network of perfectly thermally conductive wires.

This 0D approach simplifies the geometry and thus the mesh. In complex geometries, this lumped approach can reduce the amount of memory and time required for the simulation significantly.

For the modeling of the thermally resistive ceramic layers, two **Conductive Thermal Resistor** components are connected in a serial circuit.

In the steel column, the Heat Transfer in Solids interface is applied, and the coupling between the two physics, Heat Transfer in Solids (3D approach) and Lumped Thermal System (0D approach), is performed through the following features:

- **Thermal Connection** feature in the Heat Transfer in Solids interface
- **External Terminal** feature in the Lumped Thermal System interface

The complete thermal circuit modeled by the Lumped Thermal System interface is as shown in [Figure 2](#).

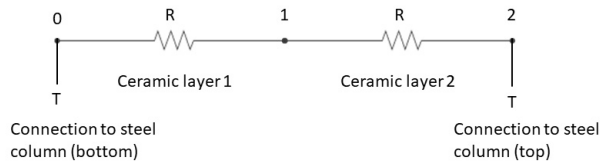

Figure 2: Thermal circuit for heat transfer in the ceramic layers.

CONDUCTIVE THERMAL RESISTOR

The **Conductive Thermal Resistor** feature models heat conduction in a thin shell of constant conductivity. In this example, a plane shell configuration is assumed, and the thermal resistance R (SI unit: K/W) of each layer is expressed from the thermal conductivity k (SI unit: W/(m·K)), the thickness L (SI unit: m), and the surface area A (SI unit: m²) as follows:

$$R = \frac{L}{kA}$$

It then assumes that the heat rate P (SI unit: W) through each layer is proportional to the temperature difference ΔT (SI unit: K) across it:

$$P = \frac{\Delta T}{R}$$

See *Theory for the Lumped Thermal System Interface* in the *Heat Transfer Module User's Guide* for more details about the underlying theory.

In case of a lumped thermal system consisting of two serially connected resistors as presented in [Figure 2](#), the total thermal resistance can be defined as the sum of the two resistances:

$$R_{tot} = R_1 + R_2$$

Such simple lumped systems can be directly encapsulated in the **Thermal Connection** feature of the Heat Transfer in Solids interface. In that case, the Lumped Thermal System physics interface is not required. This approach is demonstrated as well in the present tutorial.

MATERIAL PROPERTIES

The cylinder is made of steel. The composite consists of two layers of different ceramics.

TABLE 1: CERAMICS MATERIAL PROPERTIES.

PROPERTY	CERAMIC 1	CERAMIC 2
Thermal conductivity	1 W/(m·K)	0.5 W/(m·K)
Density	6000 kg/m ³	5800 kg/m ³
Heat capacity at constant pressure	320 J/(kg·K)	280 J/(kg·K)

BOUNDARY CONDITIONS

The temperature at the bottom is fixed to 20°C whereas one half of the top boundary is held at 1220°C (1493 K). All other outer boundaries are perfectly insulated.

Results and Discussion

Figure 3 shows the temperature distribution in the cylinder. The composite acts as a thermal barrier resulting in a jump of the temperature over the layer.

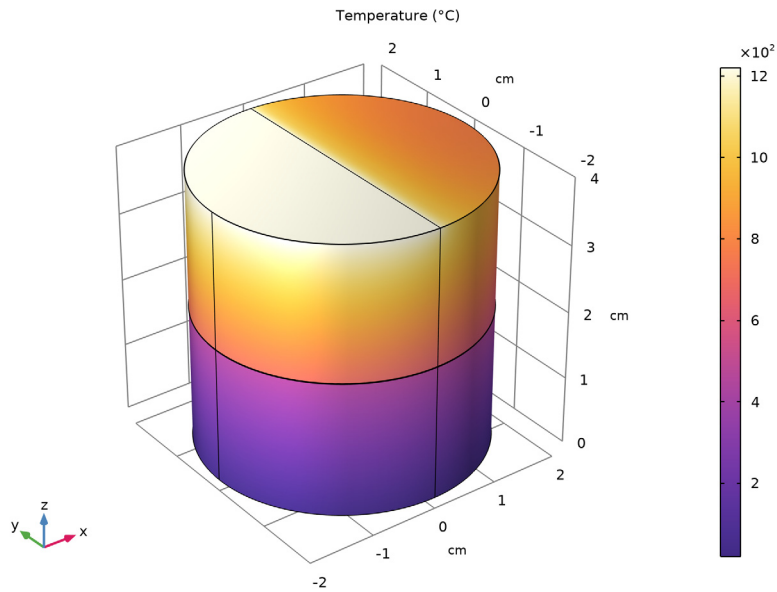

Figure 3: Temperature distribution.

Of interest is if the Lumped Thermal System approaches produce reliable results compared to resolving the thin layers in 3D. This can be done with a comparative line graph as in

Figure 4. It shows that the Lumped Thermal System approaches produce accurate results for the bulk temperatures.

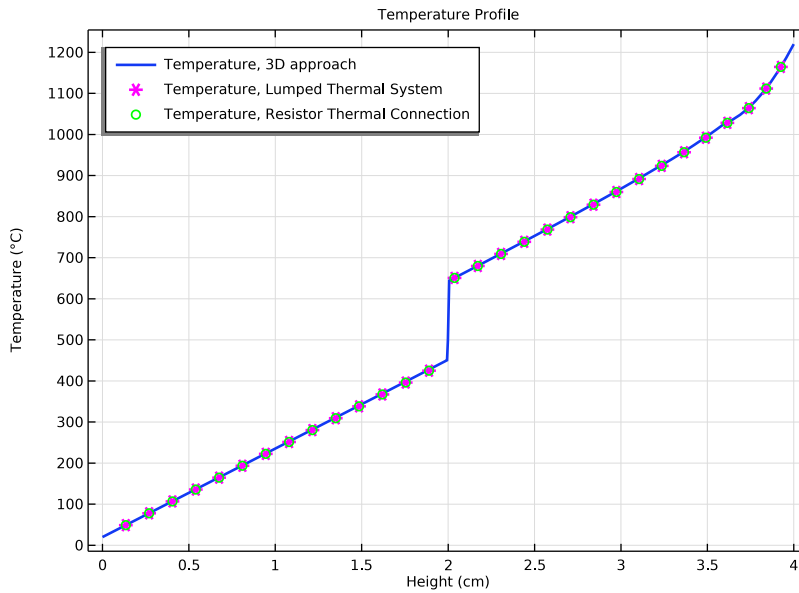

Figure 4: Temperature profile for 3D and 0D approaches.

Another important question for simulating is the influence on the mesh size and on the required RAM.

With the default tetrahedral mesh the number of mesh elements is about 130,000 elements and the meshing algorithm gives some warnings.

With the swept mesh feature you can significantly reduce the number of elements to about 2800 elements which is only 2% of the initial number of elements. In complex geometries the swept mesh algorithm may not be applicable. Using the Lumped Thermal System approach, the number of mesh elements reduces from 2800 to 2000 which is about 30% less, even in this simple geometry. You can see the number of mesh elements used in the **Messages** window below the **Graphics** window.

Notes About the COMSOL Implementation

To compare the results directly, both approaches are handled in a single MPH file.

Application Library path: Heat_Transfer_Module/Tutorials,_Thin_Structure/
lumped_composite_thermal_barrier



Modeling Instructions

From the **File** menu, choose **New**.

NEW

In the **New** window, click  **Model Wizard**.

MODEL WIZARD

- 1 In the **Model Wizard** window, click  **3D**.
- 2 In the **Select Physics** tree, select **Heat Transfer** > **Heat Transfer in Solids (ht)**.
- 3 Click **Add**.
- 4 Click  **Study**.
- 5 In the **Select Study** tree, select **General Studies** > **Stationary**.
- 6 Click  **Done**.

GLOBAL DEFINITIONS

Parameters 1



- 1 In the **Model Builder** window, under **Global Definitions** click **Parameters 1**.
- 2 In the **Settings** window for **Parameters**, locate the **Parameters** section.
- 3 In the table, enter the following settings:

Name	Expression	Value	Description
d_ceram1	50[um]	5E-5 m	Thickness of layer 1
d_ceram2	75[um]	7.5E-5 m	Thickness of layer 2
k_ceram1	1[W/(m*K)]	1 W/(m·K)	Thermal conductivity of layer 1
k_ceram2	0.5[W/(m*K)]	0.5 W/(m·K)	Thermal conductivity of layer 2
T_hot	1220[degC]	1493.2 K	Hot temperature

GEOMETRY I



- 1 In the **Model Builder** window, under **Component 1 (comp1)** click **Geometry I**.
- 2 In the **Settings** window for **Geometry**, locate the **Units** section.
- 3 From the **Length unit** list, choose **cm**.

Cylinder 1 (cyl1)



- 1 In the **Geometry** toolbar, click  **Cylinder**.
- 2 In the **Settings** window for **Cylinder**, locate the **Size and Shape** section.
- 3 In the **Radius** text field, type 2.
- 4 In the **Height** text field, type 4.
- 5 In the **Geometry** toolbar, click  **Build All**.

Now, create thin cylinders to define the ceramic layers between the two steel domains.

Cylinder 2 (cyl2)

- 1 In the **Geometry** toolbar, click  **Cylinder**.
- 2 In the **Settings** window for **Cylinder**, locate the **Size and Shape** section.
- 3 In the **Radius** text field, type 2.
- 4 In the **Height** text field, type d_{ceram1} .
- 5 Locate the **Position** section. In the **z** text field, type $2 - (d_{\text{ceram1}} + d_{\text{ceram2}}) / 2$.
- 6 In the **Geometry** toolbar, click  **Build All**.

Cylinder 3 (cyl3)

- 1 In the **Geometry** toolbar, click  **Cylinder**.
- 2 In the **Settings** window for **Cylinder**, locate the **Size and Shape** section.
- 3 In the **Radius** text field, type 2.
- 4 In the **Height** text field, type d_{ceram2} .
- 5 Locate the **Position** section. In the **z** text field, type $2 - (d_{\text{ceram1}} + d_{\text{ceram2}}) / 2 + d_{\text{ceram1}}$.
- 6 In the **Geometry** toolbar, click  **Build All**.

Polygon 1 (pol1)

- 1 In the **Geometry** toolbar, click  **More Primitives** and choose **Polygon**.
- 2 In the **Settings** window for **Polygon**, locate the **Coordinates** section.

3 In the table, enter the following settings:

x (cm)	y (cm)	z (cm)
0	-2	4
0	2	4

4 In the **Geometry** toolbar, click  **Build All**.

5 Click the  **Zoom Extents** button in the **Graphics** toolbar.

MATERIALS

Material Link 1 (matlnk1)

1 In the **Model Builder** window, under **Component 1 (comp1)** right-click **Materials** and choose **More Materials > Material Link**.

2 In the **Settings** window for **Material Link**, locate the **Link Settings** section.

3 Click  **Add Material from Library**.

ADD MATERIAL TO MATERIAL LINK 1 (MATLNK1)

1 Go to the **Add Material to Material Link 1 (matlnk1)** window.

2 In the tree, select **Built-in > Steel AISI 4340**.

3 Right-click and choose **Add Material**.

MATERIALS

Material Link 2 (matlnk2)

1 Right-click **Materials** and choose **More Materials > Material Link**.

2 In the **Settings** window for **Material Link**, locate the **Geometric Entity Selection** section.

3 Click  **Paste Selection**.

4 In the **Paste Selection** dialog, type 2 in the **Selection** text field.

5 Click **OK**.

6 In the **Settings** window for **Material Link**, locate the **Link Settings** section.

7 Click  **Blank Material**.

8 In the **Model Builder** window, click **Material Link 2 (matlnk2)**.

9 Click  **Go to Material**.

GLOBAL DEFINITIONS



Ceramic 1

- 1 In the **Model Builder** window, under **Global Definitions > Materials** click **Material 2 (mat2)**.
- 2 In the **Settings** window for **Material**, type Ceramic 1 in the **Label** text field.
- 3 Locate the **Material Contents** section. In the table, enter the following settings:

Property	Variable	Value	Unit	Property group
Thermal conductivity	k_{iso} ; $k_{ii} = k_{iso}$, $k_{ij} = 0$	k_ceram1	W/(m·K)	Basic
Density	rho	6000 [kg/m ³]	kg/m ³	Basic
Heat capacity at constant pressure	Cp	320 [J/(kg·K)]	J/(kg·K)	Basic

MATERIALS

Material Link 3 (matlnk3)

- 1 In the **Model Builder** window, under **Component 1 (comp1)** right-click **Materials** and choose **More Materials > Material Link**.
- 2 In the **Settings** window for **Material Link**, locate the **Geometric Entity Selection** section.
- 3 Click  **Paste Selection**.
- 4 In the **Paste Selection** dialog, type 3 in the **Selection** text field.
- 5 Click **OK**.
- 6 In the **Settings** window for **Material Link**, locate the **Link Settings** section.
- 7 Click  **Blank Material**.
- 8 In the **Model Builder** window, click **Material Link 3 (matlnk3)**.
- 9 Click  **Go to Material**.

GLOBAL DEFINITIONS

Ceramic 2

- 1 In the **Model Builder** window, under **Global Definitions > Materials** click **Material 3 (mat3)**.
- 2 In the **Settings** window for **Material**, type Ceramic 2 in the **Label** text field.

3 Locate the **Material Contents** section. In the table, enter the following settings:

Property	Variable	Value	Unit	Property group
Thermal conductivity	k_{iso} ; $k_{ij} = k_{iso}$, $k_{ij} = 0$	k_ceram2	W/(m·K)	Basic
Density	rho	5800 [kg/m ³]	kg/m ³	Basic
Heat capacity at constant pressure	Cp	280 [J/(kg·K)]	J/(kg·K)	Basic

HEAT TRANSFER IN SOLIDS (HT)

Temperature 1

1 In the **Physics** toolbar, click  **Boundaries** and choose **Temperature**.

2 Select Boundary 3 only.

Temperature 2

1 In the **Physics** toolbar, click  **Boundaries** and choose **Temperature**.

2 Select Boundary 13 only.

3 In the **Settings** window for **Temperature**, locate the **Temperature** section.

4 In the T_0 text field, type T_{hot} .

MESH 1

First, mesh the top surface with a free triangular mesh and extrude it in layers through the cylindrical geometry. With a **Distribution** node, specify how many mesh layers are to be created within the domain. Resolve the composite layers with two elements in thickness.

Free Triangular 1

1 In the **Mesh** toolbar, click  **More Generators** and choose **Free Triangular**.

2 Select Boundaries 13 and 18 only.

3 In the **Settings** window for **Free Triangular**, click  **Build Selected**.

Swept 1

In the **Mesh** toolbar, click  **Swept**.

Distribution 1

1 Right-click **Swept 1** and choose **Distribution**.

2 Select Domains 2 and 3 only.

3 In the **Settings** window for **Distribution**, locate the **Distribution** section.

- 4 In the **Number of elements** text field, type 2.
- 5 Click  **Build All**.



STUDY 1: 3D APPROACH

- 1 In the **Model Builder** window, right-click **Study 1** and choose **Rename**.
- 2 In the **Rename Study** dialog, type Study 1: 3D approach in the **New label** text field.
- 3 Click **OK**.
- 4 In the **Study** toolbar, click  **Compute**.

RESULTS

Change the unit of the temperature results to degrees Celsius.

Preferred Units I

- 1 In the **Results** toolbar, click  **Configurations** and choose **Preferred Units**.
- 2 In the **Settings** window for **Preferred Units**, locate the **Units** section.
- 3 Click  **Add Physical Quantity**.
- 4 In the **Physical Quantity** dialog, select **General > Temperature (K)** in the tree.
- 5 Click **OK**.
- 6 In the **Settings** window for **Preferred Units**, locate the **Units** section.
- 7 In the table, enter the following settings:

Quantity	Unit	Preferred unit
Temperature	K	°C

- 8 Click  **Apply**.

Temperature, 3D approach

The following plot is produced by default: temperature profile on the volume as in [Figure 3](#).



- 1 In the **Model Builder** window, under **Results** click **Temperature (ht)**.
- 2 In the **Settings** window for **3D Plot Group**, type Temperature, 3D approach in the **Label** text field.

Create now the second model which uses the **Lumped Thermal System** interface and compare the results to the first approach.



ADD COMPONENT

In the **Model Builder** window, right-click the root node and choose **Add Component > 3D**.

ADD PHYSICS

- 1 In the **Home** toolbar, click  **Add Physics** to open the **Add Physics** window.
- 2 Go to the **Add Physics** window.
- 3 In the tree, select **Heat Transfer** > **Heat Transfer in Solids (ht)**.
- 4 Find the **Physics interfaces in study** subsection. In the table, clear the **Solve** checkbox for **Study 1: 3D approach**.
- 5 Click the **Add to Component 2** button in the window toolbar.
- 6 In the tree, select **Heat Transfer** > **Lumped Thermal System (Its)**.
- 7 In the table, clear the **Solve** checkbox for **Study 1: 3D approach**.
- 8 Click the **Add to Component 2** button in the window toolbar.
- 9 In the **Home** toolbar, click  **Add Physics** to close the **Add Physics** window.

ADD STUDY

- 1 In the **Home** toolbar, click  **Add Study** to open the **Add Study** window.
- 2 Go to the **Add Study** window.
- 3 Find the **Studies** subsection. In the **Select Study** tree, select **General Studies** > **Stationary**.
- 4 Find the **Physics interfaces in study** subsection. In the table, clear the **Solve** checkbox for **Heat Transfer in Solids (ht)**.
- 5 Click the **Add Study** button in the window toolbar.
- 6 In the **Home** toolbar, click  **Add Study** to close the **Add Study** window.

GEOMETRY 2

- 1 In the **Settings** window for **Geometry**, locate the **Units** section.
- 2 From the **Length unit** list, choose **cm**.

Cylinder 1 (cyl1)

- 1 In the **Geometry** toolbar, click  **Cylinder**.
- 2 In the **Settings** window for **Cylinder**, locate the **Size and Shape** section.
- 3 In the **Radius** text field, type 2.
- 4 In the **Height** text field, type $2 - (d_ceram1 + d_ceram2) / 2$.

Cylinder 2 (cyl2)

- 1 In the **Geometry** toolbar, click  **Cylinder**.
- 2 In the **Settings** window for **Cylinder**, locate the **Size and Shape** section.
- 3 In the **Radius** text field, type 2.

- 4 In the **Height** text field, type $2 - (d_ceram1 + d_ceram2) / 2$.
- 5 Locate the **Position** section. In the **z** text field, type $2 + (d_ceram1 + d_ceram2) / 2$.
- 6 In the **Geometry** toolbar, click  **Build All**.

Polygon 1 (pol1)

- 1 In the **Geometry** toolbar, click  **More Primitives** and choose **Polygon**.
- 2 In the **Settings** window for **Polygon**, locate the **Coordinates** section.
- 3 In the table, enter the following settings:

x (cm)	y (cm)	z (cm)
0	-2	4
0	2	4

- 4 In the **Geometry** toolbar, click  **Build All**.
- 5 Click the  **Zoom Extents** button in the **Graphics** toolbar.

MATERIALS

Material Link 4 (matlnk4)

In the **Model Builder** window, under **Component 2 (comp2)** right-click **Materials** and choose **More Materials > Material Link**.

LUMPED THERMAL SYSTEM (LTS)

Ceramic 1

- 1 In the **Physics** toolbar, click  **Global** and choose **Conductive Thermal Resistor**.
- 2 In the **Settings** window for **Conductive Thermal Resistor**, type Ceramic 1 in the **Label** text field.
- 3 Locate the **Component Parameters** section. From the **Specify** list, choose **Thermal and geometric properties**.
- 4 From the **Material** list, choose **Ceramic 1 (mat2)**.
- 5 In the **A** text field, type $\pi * (2[\text{cm}])^2$.
- 6 In the **L** text field, type d_ceram1 .

Ceramic 2

- 1 Right-click **Ceramic 1** and choose **Duplicate**.
- 2 In the **Settings** window for **Conductive Thermal Resistor**, type Ceramic 2 in the **Label** text field.

- 3 Locate the **Component Parameters** section. From the **Material** list, choose **Ceramic 2 (mat3)**.
- 4 In the L text field, type d_ceram2.
- 5 Locate the **Node Connections** section. In the table, enter the following settings:

Label	Node names
p1	1
p2	2

External Terminal 1 (term1)

- 1 In the **Physics** toolbar, click  **Global** and choose **External Terminal**.
- 2 In the **Settings** window for **External Terminal**, locate the **Node Connections** section.
- 3 In the **Node name** text field, type 0.



External Terminal 2 (term2)

- 1 In the **Physics** toolbar, click  **Global** and choose **External Terminal**.
- 2 In the **Settings** window for **External Terminal**, locate the **Node Connections** section.
- 3 In the **Node name** text field, type 2.

HEAT TRANSFER IN SOLIDS 2 (HT2)

Add **Thermal Connection** feature on top and bottom boundaries of the composite barrier to connect the **External Terminal** features added previously.

Thermal Connection 1

- 1 In the **Physics** toolbar, click  **Global** and choose **Thermal Connection**.
- 2 In the **Settings** window for **Thermal Connection**, locate the **Boundary Selection, Connector 1** section.
- 3 Click  **Paste Selection**.
- 4 In the **Paste Selection** dialog, type 4 in the **Selection** text field.
- 5 Click **OK**.
- 6 In the **Settings** window for **Thermal Connection**, locate the **Boundary Selection, Connector 2** section.
- 7 Click  **Paste Selection**.
- 8 In the **Paste Selection** dialog, type 7 in the **Selection** text field.
- 9 Click **OK**.
- 10 In the **Settings** window for **Thermal Connection**, locate the **Thermal Connection** section.

- 11 From the **Connection type** list, choose **Lumped thermal system**.
- 12 Find the **Connector 2** subsection. From the $P_{\text{ext},2}$ list, choose **External Terminal 2 (term2) (Its/term2)**.

Temperature 1



- 1 In the **Physics** toolbar, click  **Boundaries** and choose **Temperature**.
- 2 Select Boundary 3 only.

Temperature 2

- 1 In the **Physics** toolbar, click  **Boundaries** and choose **Temperature**.
- 2 Select Boundary 8 only.
- 3 In the **Settings** window for **Temperature**, locate the **Temperature** section.
- 4 In the T_0 text field, type T_hot.

MESH 2

Free Triangular 1

- 1 In the **Mesh** toolbar, click  **More Generators** and choose **Free Triangular**.
- 2 Select Boundaries 8 and 11 only.
- 3 In the **Settings** window for **Free Triangular**, click  **Build Selected**.

Swept 1

- 1 In the **Mesh** toolbar, click  **Swept**.
- 2 In the **Settings** window for **Swept**, click  **Build All**.

STUDY 2: LUMPED THERMAL SYSTEM APPROACH

- 1 In the **Model Builder** window, right-click **Study 2** and choose **Rename**.
- 2 In the **Rename Study** dialog, type Study 2: Lumped Thermal System approach in the **New label** text field.
- 3 Click **OK**.
- 4 In the **Study** toolbar, click  **Compute**.

RESULTS

Temperature, Lumped Thermal System approach



In the **Settings** window for **3D Plot Group**, type Temperature, Lumped Thermal System approach in the **Label** text field.

Create now the third model which represents a simplified version of the second model. It simulates the same lumped thermal system but with one single resistor of resistance R_{tot} previously defined. Such simple systems with one single resistor can be defined directly in **Thermal Connection** boundary feature. Create this model and compare the results to the previous approaches.



ADD COMPONENT

In the **Model Builder** window, right-click the root node and choose **Add Component** > **3D**.

ADD PHYSICS

- 1 In the **Home** toolbar, click  **Add Physics** to open the **Add Physics** window.
- 2 Go to the **Add Physics** window.
- 3 In the tree, select **Heat Transfer** > **Heat Transfer in Solids (ht)**.
- 4 Find the **Physics interfaces in study** subsection. In the table, clear the **Solve** checkboxes for **Study 1: 3D approach** and **Study 2: Lumped Thermal System approach**.
- 5 Click the **Add to Component 3** button in the window toolbar.
- 6 In the **Home** toolbar, click  **Add Physics** to close the **Add Physics** window.

ADD STUDY

- 1 In the **Home** toolbar, click  **Add Study** to open the **Add Study** window.
- 2 Go to the **Add Study** window.
- 3 Find the **Studies** subsection. In the **Select Study** tree, select **General Studies** > **Stationary**.
- 4 Find the **Physics interfaces in study** subsection. In the table, clear the **Solve** checkboxes for **Heat Transfer in Solids (ht)**, **Heat Transfer in Solids 2 (ht2)**, and **Lumped Thermal System (Its)**.
- 5 Click the **Add Study** button in the window toolbar.
- 6 In the **Home** toolbar, click  **Add Study** to close the **Add Study** window.

GEOMETRY 3



- 1 In the **Settings** window for **Geometry**, locate the **Units** section.
- 2 From the **Length unit** list, choose **cm**.

Cylinder 1 (cyl1)

- 1 In the **Geometry** toolbar, click  **Cylinder**.
- 2 In the **Settings** window for **Cylinder**, locate the **Size and Shape** section.
- 3 In the **Radius** text field, type 2.

4 In the **Height** text field, type $2 - (d_ceram1 + d_ceram2) / 2$.



Cylinder 2 (cyl2)

- 1 In the **Geometry** toolbar, click  **Cylinder**.
- 2 In the **Settings** window for **Cylinder**, locate the **Size and Shape** section.
- 3 In the **Radius** text field, type 2.
- 4 In the **Height** text field, type $2 - (d_ceram1 + d_ceram2) / 2$.
- 5 Locate the **Position** section. In the **z** text field, type $2 + (d_ceram1 + d_ceram2) / 2$.
- 6 In the **Geometry** toolbar, click  **Build All**.

Polygon 1 (pol1)

- 1 In the **Geometry** toolbar, click  **More Primitives** and choose **Polygon**.
- 2 In the **Settings** window for **Polygon**, locate the **Coordinates** section.
- 3 In the table, enter the following settings:

x (cm)	y (cm)	z (cm)
0	-2	4
0	2	4

- 4 In the **Geometry** toolbar, click  **Build All**.
- 5 Click the  **Zoom Extents** button in the **Graphics** toolbar.



MATERIALS

Material Link 5 (matlnk5)

In the **Model Builder** window, under **Component 3 (comp3)** right-click **Materials** and choose **More Materials > Material Link**.

HEAT TRANSFER IN SOLIDS 3 (HT3)

Thermal Connection 1

- 1 In the **Physics** toolbar, click  **Global** and choose **Thermal Connection**.
- 2 In the **Settings** window for **Thermal Connection**, locate the **Boundary Selection, Connector 1** section.
- 3 Click  **Paste Selection**.
- 4 In the **Paste Selection** dialog, type 4 in the **Selection** text field.
- 5 Click **OK**.

- 6 In the **Settings** window for **Thermal Connection**, locate the **Boundary Selection, Connector 2** section.
- 7 Click  **Paste Selection**.
- 8 In the **Paste Selection** dialog, type 7 in the **Selection** text field.
- 9 Click **OK**.
- 10 In the **Settings** window for **Thermal Connection**, locate the **Thermal Connection** section.
- 11 In the R text field, type $(d_ceram1/k_ceram1+d_ceram2/k_ceram2)/(pi*(2[cm])^2)$.

Temperature 1



- 1 In the **Physics** toolbar, click  **Boundaries** and choose **Temperature**.
- 2 Select Boundary 3 only.

Temperature 2

- 1 In the **Physics** toolbar, click  **Boundaries** and choose **Temperature**.
- 2 Select Boundary 8 only.
- 3 In the **Settings** window for **Temperature**, locate the **Temperature** section.
- 4 In the T_0 text field, type T_hot .

MESH 3

Free Triangular 1

- 1 In the **Mesh** toolbar, click  **More Generators** and choose **Free Triangular**.
- 2 Select Boundaries 8 and 11 only.
- 3 In the **Settings** window for **Free Triangular**, click  **Build Selected**.

Swept 1

- 1 In the **Mesh** toolbar, click  **Swept**.
- 2 In the **Settings** window for **Swept**, click  **Build All**.

STUDY 3: RESISTOR THERMAL CONNECTION APPROACH

- 1 In the **Model Builder** window, right-click **Study 3** and choose **Rename**.
- 2 In the **Rename Study** dialog, type Study 3: Resistor Thermal Connection approach in the **New label** text field.
- 3 Click **OK**.
- 4 In the **Study** toolbar, click  **Compute**.

RESULTS

Temperature, Resistor Thermal Connection approach

In the **Settings** window for **3D Plot Group**, type Temperature, Resistor Thermal Connection approach in the **Label** text field.

Next, create a temperature profile along the height of the cylinder and compare the profiles from the three approaches.

Temperature Profiles

- 1 In the **Results** toolbar, click  **ID Plot Group**.
- 2 In the **Settings** window for **ID Plot Group**, type Temperature Profiles in the **Label** text field.
- 3 Locate the **Plot Settings** section.
- 4 Select the **x-axis label** checkbox. In the associated text field, type Height (cm).
- 5 Click to expand the **Title** section. From the **Title type** list, choose **Manual**.
- 6 In the **Title** text area, type Temperature Profile.
- 7 Locate the **Legend** section. From the **Position** list, choose **Upper left**.
- 8 In the **Maximum relative width** text field, type 0.6.

Line Graph 1

- 1 Right-click **Temperature Profiles** and choose **Line Graph**.
- 2 Select Edges 15, 17, 19, and 21 only.
- 3 In the **Settings** window for **Line Graph**, locate the **Data** section.
- 4 From the **Dataset** list, choose **Study 1: 3D approach/Solution 1 (sol1)**.
- 5 Locate the **x-Axis Data** section. From the **Parameter** list, choose **Expression**.
- 6 In the **Expression** text field, type z.
- 7 Click to expand the **Coloring and Style** section. From the **Width** list, choose **2**.
- 8 Click to expand the **Legends** section. Select the **Show legends** checkbox.
- 9 From the **Legends** list, choose **Manual**.
- 10 In the table, enter the following settings:

Legends
Temperature, 3D approach

Line Graph 2

- 1 In the **Model Builder** window, right-click **Temperature Profiles** and choose **Line Graph**.

- 2 In the **Settings** window for **Line Graph**, locate the **Data** section.
- 3 From the **Dataset** list, choose **Study 2: Lumped Thermal System approach/ Solution 2 (3) (sol2)**.
- 4 Select Edges 11 and 14 only.
- 5 Locate the **y-Axis Data** section. In the **Expression** text field, type T2.
- 6 Locate the **x-Axis Data** section. From the **Parameter** list, choose **Expression**.
- 7 In the **Expression** text field, type z.
- 8 Locate the **Coloring and Style** section. Find the **Line style** subsection. From the **Line** list, choose **None**.
- 9 From the **Color** list, choose **Magenta**.
- 10 Find the **Line markers** subsection. From the **Marker** list, choose **Asterisk**.
- 11 From the **Positioning** list, choose **Interpolated**.
- 12 In the **Number** text field, type 30.
- 13 Locate the **Legends** section. Select the **Show legends** checkbox.
- 14 From the **Legends** list, choose **Manual**.
- 15 In the table, enter the following settings:

Legends

Temperature, Lumped Thermal System

Line Graph 3

- 1 Right-click **Temperature Profiles** and choose **Line Graph**.
- 2 In the **Settings** window for **Line Graph**, locate the **Data** section.
- 3 From the **Dataset** list, choose **Study 3: Resistor Thermal Connection approach/ Solution 3 (6) (sol3)**.
- 4 Select Edges 11 and 14 only.
- 5 Locate the **y-Axis Data** section. In the **Expression** text field, type T3.
- 6 Locate the **x-Axis Data** section. From the **Parameter** list, choose **Expression**.
- 7 In the **Expression** text field, type z.
- 8 Locate the **Coloring and Style** section. Find the **Line style** subsection. From the **Line** list, choose **None**.
- 9 Find the **Line markers** subsection. From the **Marker** list, choose **Circle**.
- 10 From the **Color** list, choose **Green**.
- 11 From the **Positioning** list, choose **Interpolated**.

12 In the **Number** text field, type 30.

13 Locate the **Legends** section. Select the **Show legends** checkbox.

14 From the **Legends** list, choose **Manual**.

15 In the table, enter the following settings:

Legends

Temperature, Resistor Thermal Connection

16 In the **Temperature Profiles** toolbar, click  **Plot**.

The plot should look like that in [Figure 4](#).