



Model created in COMSOL Multiphysics 6.4

# Radiative Cooling of a Glass Plate

## Introduction

---

In glass production, the glass melt is cooled down mainly by radiation. To avoid stresses it is important to evenly cool the glass body.

Numerical treatment of radiative heat transfer helps to optimize this cooling process. The governing equation — the Radiative Transfer Equation (RTE) — is an integro-differential equation that requires a lot of computational resources to be solved. Therefore, COMSOL Multiphysics offers three common methods to solve the RTE along with the heat transfer equation.

This tutorial is intended to show the typical set up of all methods computing the heat transfer by radiation inside a gray medium.

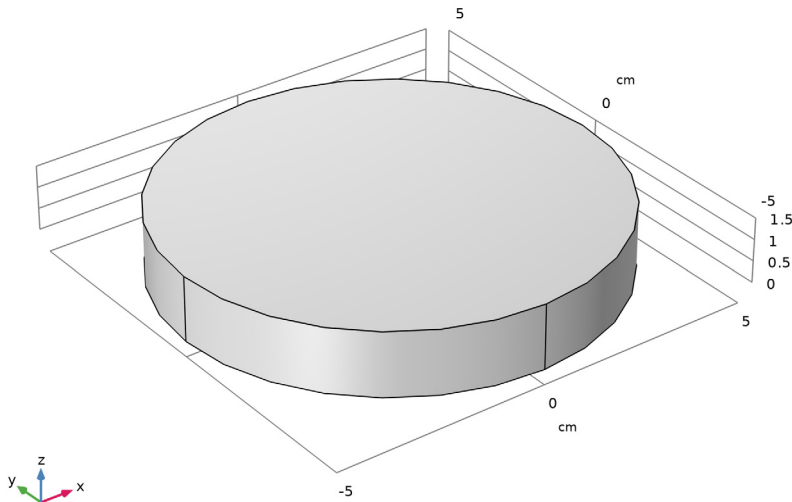

*Figure 1: Cylindrical glass plate.*

## Model Definition

---

The model geometry is shown in [Figure 1](#). It is a cylinder of radius  $r = 5$  cm and height  $h = 1.5$  cm. The radiative cooling starts from an initial temperature of  $600^{\circ}\text{C}$  due to radiation into an ambient surrounding at  $20^{\circ}\text{C}$ . Convective cooling is neglected, which is reasonable for high temperatures as in this model.

The material properties for the glass body are summarized in [Table 1](#).

TABLE 1: MATERIAL PROPERTIES FOR GLASS.

| MATERIAL PROPERTY                  | VALUE                  |
|------------------------------------|------------------------|
| Thermal conductivity               | 1.2 W/(m·K)            |
| Density                            | 2200 kg/m <sup>3</sup> |
| Heat capacity at constant pressure | 850 J/(kg·K)           |
| Scattering coefficient             | 0                      |

Scattering effects are neglected. For the absorption coefficient, a parametric sweep is used to get results for  $k = 5, 70, 120$ . The boundaries of the glass body have a surface emissivity,  $\epsilon$ , equal to 1.

### THERMAL ANALYSIS

A detailed explanation about the discrete ordinates method and the PI method can be found in [Radiative Heat Transfer in Finite Cylindrical Media](#) or [Radiative Heat Transfer in Finite Cylindrical Media — PI Method](#) respectively.

The Rosseland approximation is a simplified method that results in an additional nonlinear term for the thermal conductivity. Hence, this method has almost no impact on the computational cost.

For large optical thickness where the integral of the absorption coefficient along a typical path is large, radiation effects only spread at its close surrounding and does not travel far through the medium before being absorbed or scattered. This leads to a diffusion-like equation for the radiative heat flux ([Ref. 1](#)):

$$q_{r,\lambda} = -\frac{4\pi}{3\beta_\lambda} \nabla I_{b,\lambda}$$

For a gray medium (after integration over all wave numbers) the radiative heat flux depends on the temperature gradient and can be expressed as:

$$q_r = -k_r \nabla T$$

where  $k_r$  is a highly nonlinear coefficient, considered as a conductivity, for radiative transfer of the form

$$k_r = \frac{16n^2\sigma T^3}{3\beta_r}$$

with  $\beta_r$ , the Rosseland-mean extinction coefficient,  $\sigma$  the scattering coefficient and  $n$  the refractive index. Thus the Rosseland approximation method is also called the diffusion method.

### Results and Discussion

---

The figures below compare the results for a low and a high absorption coefficient. The P1 method provides a very good approximation for lower absorption coefficients (Figure 2), but with increasing absorption coefficients the results differ increasingly.

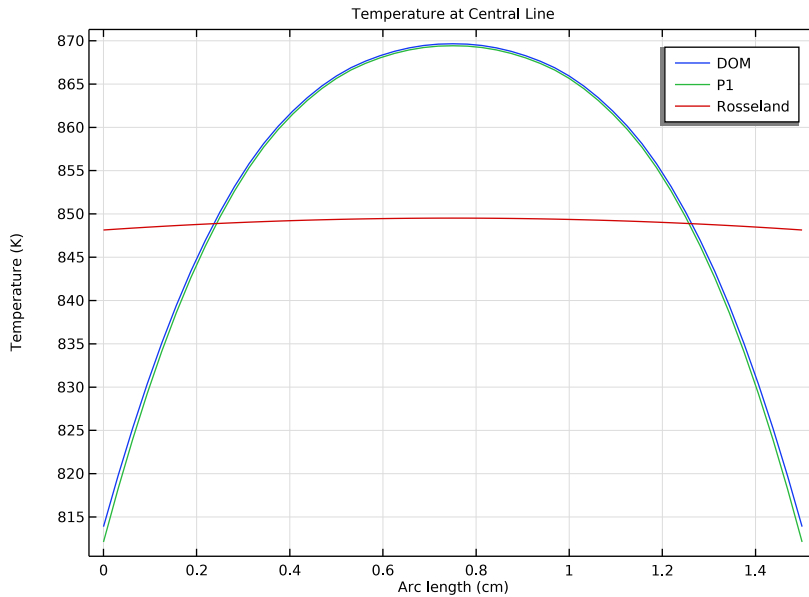

Figure 2: Vertical temperature distribution at the center of the cylinder for  $k = 5$ .

The Rosseland approximation provides a fast and satisfying solution for the temperature field when a very high absorption coefficient or a rather high optical thickness is considered (Figure 3).

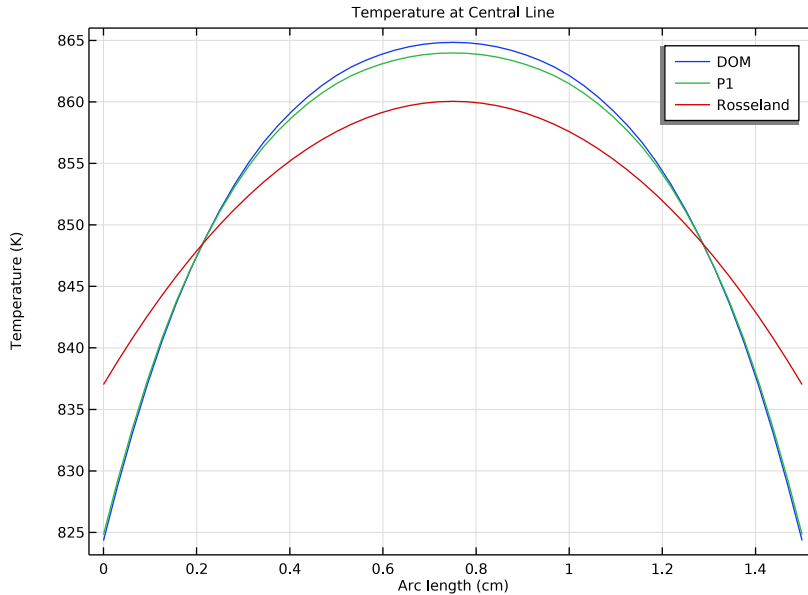

Figure 3: Vertical temperature distribution at the center of the cylinder for  $k = 120$ .

Both methods need to be used carefully and it is recommended to validate their applicability. If they can be used, they provide a very fast solution compared to the highly accurate discrete ordinates method.

### Reference

---

1. M.F. Modest, *Radiative Heat Transfer*, 2nd ed., Academic Press, 2003.

---

**Application Library path:** Heat\_Transfer\_Module/Thermal\_Radiation/  
glass\_plate

---

## Modeling Instructions



---

From the **File** menu, choose **New**.

### NEW

In the **New** window, click  **Model Wizard**.

### MODEL WIZARD

- 1 In the **Model Wizard** window, click .
- 2 In the **Select Physics** tree, select **Heat Transfer > Radiation > Heat Transfer with Radiation in Participating Media**.
- 3 Click **Add**.
- 4 Click  **Study**.
- 5 In the **Select Study** tree, select **General Studies > Time Dependent**.
- 6 Click  **Done**.

### GLOBAL DEFINITIONS

#### Parameters 1

- 1 In the **Model Builder** window, under **Global Definitions** click **Parameters 1**.
- 2 In the **Settings** window for **Parameters**, locate the **Parameters** section.
- 3 In the table, enter the following settings:

| Name  | Expression | Value    | Description            |
|-------|------------|----------|------------------------|
| nr    | 1.45       | 1.45     | Refractive index       |
| T0    | 600[degC]  | 873.15 K | Initial temperature    |
| T_amb | 20[degC]   | 293.15 K | Ambient temperature    |
| k     | 5[1/m]     | 5 1/m    | Absorption coefficient |

### GEOMETRY 1

- 1 In the **Model Builder** window, under **Component 1 (comp1)** click **Geometry 1**.
- 2 In the **Settings** window for **Geometry**, locate the **Units** section.
- 3 From the **Length unit** list, choose **cm**.

#### Cylinder 1 (cyl1)

- 1 In the **Geometry** toolbar, click  **Cylinder**.
- 2 In the **Settings** window for **Cylinder**, locate the **Size and Shape** section.

- 3 In the **Radius** text field, type 5.
- 4 In the **Height** text field, type 1.5.
- 5 In the **Geometry** toolbar, click  **Build All**.

Create a user-defined material for the glass body.

## GLOBAL DEFINITIONS

### *Glass*

- 1 In the **Model Builder** window, under **Global Definitions** right-click **Materials** and choose **Blank Material**.
- 2 In the **Settings** window for **Material**, type Glass in the **Label** text field.

## MATERIALS

### *Material Link 1 (matlnk1)*

In the **Model Builder** window, under **Component 1 (comp1)** right-click **Materials** and choose **More Materials > Material Link**.

### *Material Link 2 (matlnk2)*

- 1 Right-click **Materials** and choose **More Materials > Material Link**.
- 2 In the **Settings** window for **Material Link**, locate the **Geometric Entity Selection** section.
- 3 From the **Geometric entity level** list, choose **Boundary**.
- 4 From the **Selection** list, choose **All boundaries**.

## GLOBAL DEFINITIONS

### *Glass (mat1)*

- 1 In the **Model Builder** window, under **Global Definitions > Materials** click **Glass (mat1)**.
- 2 In the **Settings** window for **Material**, locate the **Material Contents** section.

3 In the table, enter the following settings:

| Property                           | Variable                                      | Value                       | Unit              | Property group |
|------------------------------------|---|-----------------------------|-------------------|----------------|
| Thermal conductivity               | $k_{iso}$ ; $k_{ij} = k_{iso}$ , $k_{ij} = 0$ | 1.2 [W/ (m* K) ]            | W/(m·K)           | Basic          |
| Density                            | $\rho$  | 2200 [ kg/ m <sup>3</sup> ] | kg/m <sup>3</sup> | Basic          |
| Heat capacity at constant pressure | $C_p$   | 850 [ J/ (kg·K) ]           | J/(kg·K)          | Basic          |

For radiative heat transfer, the absorption and scattering coefficients are also needed. Add these properties to the material.

4 In the table, enter the following settings:

| Property               | Variable   | Value       | Unit | Property group |
|------------------------|------------|-------------|------|----------------|
| Absorption coefficient | $\kappa_R$ | k           | 1/m  | Basic          |
| Scattering coefficient | $\sigma_S$ | 0 [ 1 / m ] | 1/m  | Basic          |

The boundary condition for radiative cooling requires a surface emissivity. One way to define this coefficient is to add a material for the boundaries.

5 In the table, enter the following settings:

| Property           | Variable         | Value | Unit | Property group |
|--------------------|------------------|-------|------|----------------|
| Surface emissivity | $\epsilon_{rad}$ | 1     | 1    | Basic          |

Start with the discrete ordinates method to compute the radiative cooling of the glass plate. This method provides the most accurate solution for arbitrary radiation models and is therefore the default method for radiation in participating media.

### RADIATION IN PARTICIPATING MEDIA (RPM)

- 1 In the **Model Builder** window, under **Component 1 (comp1)** click **Radiation in Participating Media (rpm)**.
- 2 In the **Settings** window for **Radiation in Participating Media**, locate the **Participating Media Settings** section.
- 3 Find the **Radiation settings** subsection. In the  $n_r$  text field, type nr.

## HEAT TRANSFER IN SOLIDS (HT)

### *Initial Values 1*

- 1 In the **Model Builder** window, under **Component 1 (comp1) > Heat Transfer in Solids (ht)** click **Initial Values 1**.
- 2 In the **Settings** window for **Initial Values**, locate the **Initial Values** section.
- 3 In the  $T$  text field, type  $T_0$ .  
Set the initial temperature to 600°C.

### *Surface-to-Ambient Radiation 1*

- 1 In the **Physics** toolbar, click  **Boundaries** and choose **Surface-to-Ambient Radiation**.
- 2 In the **Settings** window for **Surface-to-Ambient Radiation**, locate the **Boundary Selection** section.
- 3 From the **Selection** list, choose **All boundaries**.
- 4 Locate the **Surface-to-Ambient Radiation** section. In the  $T_{\text{amb}}$  text field, type  $T_{\text{amb}}$ .

## MESH 1

Build a suitable mesh manually. First, mesh the surface with a free triangular mesh and then add a swept mesh.

### *Free Triangular 1*

- 1 In the **Mesh** toolbar, click  **More Generators** and choose **Free Triangular**.
- 2 Select Boundary 4 only.

### *Size 1*

- 1 In the **Mesh** toolbar, click **Size Attribute** and choose **Extra Fine**.
- 2 In the **Settings** window for **Size**, locate the **Geometric Entity Selection** section.
- 3 From the **Geometric entity level** list, choose **Edge**.
- 4 Select Edges 4, 5, 8, and 11 only.

### *Size 2*

- 1 In the **Mesh** toolbar, click **Size Attribute** and choose **Fine**.
- 2 In the **Settings** window for **Size**, click  **Build Selected**.

### *Swept 1*

In the **Mesh** toolbar, click  **Swept**.

### *Distribution 1*

- 1 Right-click **Swept 1** and choose **Distribution**.

- 2 In the **Settings** window for **Distribution**, locate the **Distribution** section.
- 3 In the **Number of elements** text field, type 8.
- 4 Click  **Build Selected**.

The mesh should look like that in the figure below.

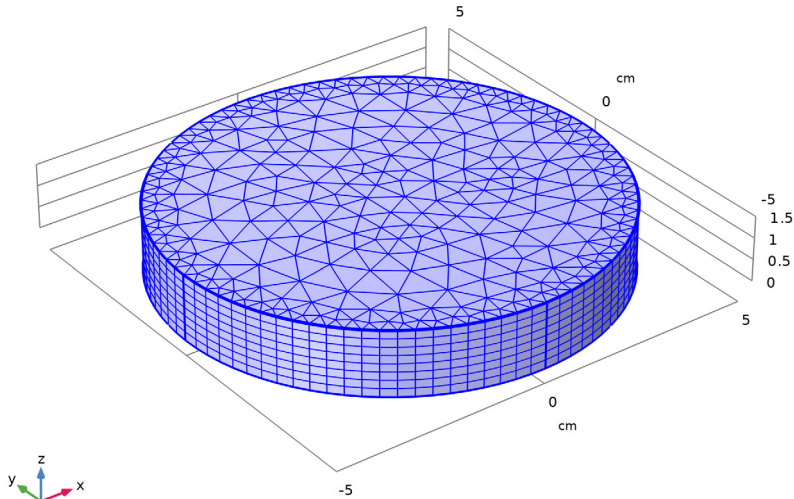

### STUDY 1: DOM

Next, rename the study node to identify the studies and the related solutions easily.



- 1 In the **Model Builder** window, click **Study 1**.
- 2 In the **Settings** window for **Study**, type Study 1: DOM in the **Label** text field.

#### *Step 1: Time Dependent*

The model only compares the results after 10 seconds. To keep the file size small, let COMSOL Multiphysics store only this time step in the file. The computational time step is chosen automatically.

- 1 In the **Model Builder** window, under **Study 1: DOM** click **Step 1: Time Dependent**.
- 2 In the **Settings** window for **Time Dependent**, locate the **Study Settings** section.
- 3 In the **Output times** text field, type 10.

### Parametric Sweep

- 1 In the **Study** toolbar, click  **Parametric Sweep**.
- 2 In the **Settings** window for **Parametric Sweep**, locate the **Study Settings** section.
- 3 Click  **Add**.
- 4 In the table, enter the following settings:

| Parameter name             | Parameter value list | Parameter unit |
|----------------------------|----------------------|----------------|
| k (Absorption coefficient) | 5 70 120             | 1 /m           |

When a model involves the discrete ordinates method, the memory requirement during computation is generally lead by the radiative intensities since there are as many dependent variables as the number of directions accounted for. By default with the discrete ordinates method, a **Direct, radiation variables** solver is used to solve for the radiative intensities since it is generally the fastest. If it requires too much memory, the **AMG, radiation variables** iterative solver is an alternative that is more economical in memory. Follow these steps to select the linear solver used for the computation of radiative intensities.

### Solution 1 (sol1)

- 1 In the **Study** toolbar, click  **Show Default Solver**.
- 2 In the **Model Builder** window, expand the **Solution 1 (sol1)** node.
- 3 In the **Model Builder** window, expand the **Solution 1 (sol1) > Time-Dependent Solver 1** node.
- 4 In the **Model Builder** window, expand the **Solution 1 (sol1) > Time-Dependent Solver 1 > Segregated 1** node, then click **Radiative Intensities 1**.

This segregated step controls the computation of all radiative intensities. If you have more than 10 GB of RAM, keep the default **Direct, radiation variables** solver in the **Linear solver** field. If you have less, switch to the **AMG, radiation variables** iterative solver.

- 5 In the **Settings** window for **Segregated Step**, locate the **General** section.
- 6 From the **Linear solver** list, choose either **Direct, radiation variables** or **AMG, radiation variables**.
- 7 In the **Study** toolbar, click  **Compute**.

## RESULTS

### *Temperature (ht)*

Next, run the same model but with the P1 method. The only modification to do is to change the **Radiation discretization method** in the **Heat Transfer with Radiation in Participating Media** settings window.

## ADD COMPONENT

In the **Model Builder** window, right-click the root node and choose **Add Component > 3D**.

## GEOMETRY 2

- 1 In the **Settings** window for **Geometry**, locate the **Units** section.
- 2 From the **Length unit** list, choose **cm**.

## MESH 2

### *Import 1*

- 1 In the **Mesh** toolbar, click  **Import**.
- 2 In the **Settings** window for **Import**, locate the **Import** section.
- 3 From the **Source** list, choose **Meshing sequence**.
- 4 Click **Import**.

## MATERIALS

### *Material Link 3 (matlnk3)*

In the **Model Builder** window, under **Component 2 (comp2)** right-click **Materials** and choose **More Materials > Material Link**.

### *Material Link 4 (matlnk4)*

- 1 Right-click **Materials** and choose **More Materials > Material Link**.
- 2 In the **Settings** window for **Material Link**, locate the **Geometric Entity Selection** section.
- 3 From the **Geometric entity level** list, choose **Boundary**.
- 4 From the **Selection** list, choose **All boundaries**.

## HEAT TRANSFER IN SOLIDS (HT), RADIATION IN PARTICIPATING MEDIA (RPM)

- 1 In the **Model Builder** window, under **Component 1 (comp1)**, Ctrl-click to select **Heat Transfer in Solids (ht)** and **Radiation in Participating Media (rpm)**.
- 2 Right-click and choose **Copy**.

## HEAT TRANSFER IN SOLIDS (HT2)

In the **Model Builder** window, right-click **Component 2 (comp2)** and choose **Paste Multiple Items**.

## HEAT TRANSFER IN SOLIDS (HT2), RADIATION IN PARTICIPATING MEDIA (RPM2)

In the **Messages from Paste** dialog, click **OK**.

## MULTIPHYSICS

*Heat Transfer with Radiation in Participating Media 2 (htrpm2)*

In the **Physics** toolbar, click  **Multiphysics Couplings** and choose **Domain > Heat Transfer with Radiation in Participating Media**.

## RADIATION IN PARTICIPATING MEDIA (RPM2)

- 1 In the **Model Builder** window, under **Component 2 (comp2)** click **Radiation in Participating Media (rpm2)**.
- 2 In the **Settings** window for **Radiation in Participating Media**, locate the **Participating Media Settings** section.
- 3 Find the **Radiation settings** subsection. From the **Radiation discretization method** list, choose **P1 approximation**.

To compare the results, a second study is used to compute the same setup with the P1 method. Add an empty study and copy the settings from the first one.

## ADD STUDY

- 1 In the **Home** toolbar, click  **Add Study** to open the **Add Study** window.
- 2 Go to the **Add Study** window.
- 3 Find the **Studies** subsection. In the **Select Study** tree, select **Empty Study**.
- 4 Click the **Add Study** button in the window toolbar.

## STUDY 2: P1

In the **Settings** window for **Study**, type Study 2: P1 in the **Label** text field.

## STUDY 1: DOM

*Parametric Sweep, Step 1: Time Dependent*

- 1 In the **Model Builder** window, under **Study 1: DOM**, Ctrl-click to select **Parametric Sweep** and **Step 1: Time Dependent**.

- 2 Right-click and choose **Copy**.

### STUDY 2: P I

In the **Model Builder** window, right-click **Study 2: P I** and choose **Paste Multiple Items**.

#### *Step 1: Time Dependent*

- 1 In the **Settings** window for **Time Dependent**, locate the **Physics and Variables Selection** section.
- 2 In the **Solve for** column of the table, under **Component 1 (comp1)**, clear the checkboxes for **Heat Transfer in Solids (ht)** and **Radiation in Participating Media (rpm)**.
- 3 In the **Solve for** column of the table, under **Component 1 (comp1) > Multiphysics**, clear the checkbox for **Heat Transfer with Radiation in Participating Media 1 (htrpm1)**.

### STUDY 1: D O M

- 1 In the **Model Builder** window, under **Study 1: D O M** click **Step 1: Time Dependent**.
- 2 In the **Settings** window for **Time Dependent**, locate the **Physics and Variables Selection** section.
- 3 In the **Solve for** column of the table, under **Component 2 (comp2)**, clear the checkboxes for **Heat Transfer in Solids (ht2)** and **Radiation in Participating Media (rpm2)**.
- 4 In the **Solve for** column of the table, under **Component 2 (comp2) > Multiphysics**, clear the checkbox for **Heat Transfer with Radiation in Participating Media 2 (htrpm2)**.

### STUDY 2: P I

- 1 In the **Study** toolbar, click  **Compute**.

The same procedure applies for solving with the Rosseland approximation.

### ADD COMPONENT

In the **Model Builder** window, right-click the root node and choose **Add Component > 3D**.

### GEOMETRY 3

- 1 In the **Settings** window for **Geometry**, locate the **Units** section.
- 2 From the **Length unit** list, choose **cm**.

### MESH 3

#### *Import 1*

- 1 In the **Mesh** toolbar, click  **Import**.
- 2 In the **Settings** window for **Import**, locate the **Import** section.

3 From the **Source** list, choose **Meshing sequence**.

4 Click **Import**.

## **MATERIALS**

### *Material Link 5 (matlnk5)*

In the **Model Builder** window, under **Component 3 (comp3)** right-click **Materials** and choose **More Materials > Material Link**.

### *Material Link 6 (matlnk6)*

1 Right-click **Materials** and choose **More Materials > Material Link**.

2 In the **Settings** window for **Material Link**, locate the **Geometric Entity Selection** section.

3 From the **Geometric entity level** list, choose **Boundary**.

4 From the **Selection** list, choose **All boundaries**.

## **HEAT TRANSFER IN SOLIDS (HT2)**

In the **Model Builder** window, under **Component 2 (comp2)** right-click **Heat Transfer in Solids (ht2)** and choose **Copy**.

## **HEAT TRANSFER IN SOLIDS (HT3)**

In the **Model Builder** window, right-click **Component 3 (comp3)** and choose **Paste Heat Transfer in Solids**.

## **HEAT TRANSFER IN SOLIDS (HT2)**

In the **Messages from Paste** dialog, click **OK**.

## **HEAT TRANSFER IN SOLIDS (HT3)**

### *Solid 1*

In the **Model Builder** window, under **Component 3 (comp3) > Heat Transfer in Solids (ht3)** click **Solid 1**.

### *Optically Thick Participating Medium 1*

1 In the **Physics** toolbar, click  **Attributes** and choose **Optically Thick Participating Medium**.

2 In the **Settings** window for **Optically Thick Participating Medium**, locate the **Optically Thick Participating Medium** section.

3 In the  $n_r$  text field, type nr.

## ADD STUDY

- 1 Go to the **Add Study** window.
- 2 Find the **Studies** subsection. In the **Select Study** tree, select **Empty Study**.
- 3 Click the **Add Study** button in the window toolbar.
- 4 In the **Model Builder** window, under **Component 1 (comp1)** click **Heat Transfer in Solids (ht)**.
- 5 In the **Home** toolbar, click  **Add Study** to close the **Add Study** window.

## STUDY 3: ROSSELAND

In the **Settings** window for **Study**, type Study 3: Rosseland in the **Label** text field.

## STUDY 2: P I

*Parametric Sweep, Step 1: Time Dependent*

- 1 In the **Model Builder** window, under **Study 2: P I**, Ctrl-click to select **Parametric Sweep** and **Step 1: Time Dependent**.
- 2 Right-click and choose **Copy**.

## STUDY 3: ROSSELAND

In the **Model Builder** window, right-click **Study 3: Rosseland** and choose **Paste Multiple Items**.

*Step 1: Time Dependent*

- 1 In the **Settings** window for **Time Dependent**, locate the **Physics and Variables Selection** section.
- 2 In the **Solve for** column of the table, under **Component 2 (comp2)**, clear the checkboxes for **Heat Transfer in Solids (ht2)** and **Radiation in Participating Media (rpm2)**.
- 3 In the **Solve for** column of the table, under **Component 2 (comp2) > Multiphysics**, clear the checkbox for **Heat Transfer with Radiation in Participating Media 2 (htrpm2)**.

## STUDY 1: DOM

- 1 In the **Model Builder** window, under **Study 1: DOM** click **Step 1: Time Dependent**.
- 2 In the **Settings** window for **Time Dependent**, locate the **Physics and Variables Selection** section.
- 3 In the **Solve for** column of the table, under **Component 3 (comp3)**, clear the checkbox for **Heat Transfer in Solids (ht3)**.

## STUDY 2: P1

- 1 In the **Model Builder** window, under **Study 2: P1** click **Step 1: Time Dependent**.
- 2 In the **Settings** window for **Time Dependent**, locate the **Physics and Variables Selection** section.
- 3 In the **Solve for** column of the table, under **Component 3 (comp3)**, clear the checkbox for **Heat Transfer in Solids (ht3)**.

## STUDY 3: ROSSELAND

In the **Study** toolbar, click  **Compute**.

## RESULTS

### *Incident Radiation (rpm2)*

To compare the results, add a temperature plot along the centerline of the glass plate. Therefore create a cut line dataset for each parametric solution.

### *Cut Line 3D 1*

- 1 In the **Model Builder** window, expand the **Results > Datasets** node.
- 2 Right-click **Results > Datasets** and choose **Cut Line 3D**.
- 3 In the **Settings** window for **Cut Line 3D**, locate the **Data** section.
- 4 From the **Dataset** list, choose **Study 1: DOM/Parametric Solutions 1 (sol2)**.
- 5 Locate the **Line Data** section. In row **Point 2**, set **X** to 0, and **z** to 1.5.

6 Click  **Plot**.

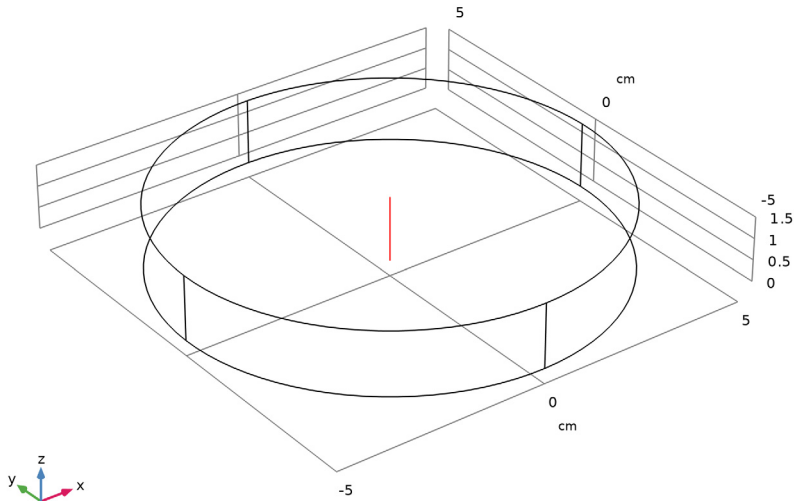

Copy the dataset twice and assign the solutions from the other studies.

#### *Cut Line 3D 2*

- 1 Right-click **Cut Line 3D 1** and choose **Duplicate**.
- 2 In the **Settings** window for **Cut Line 3D**, locate the **Data** section.
- 3 From the **Dataset** list, choose **Study 2: PI/Parametric Solutions 2 (6) (sol7)**.

#### *Cut Line 3D 3*

- 1 Right-click **Cut Line 3D 2** and choose **Duplicate**.
- 2 In the **Settings** window for **Cut Line 3D**, locate the **Data** section.
- 3 From the **Dataset** list, choose **Study 3: Rosseland/Parametric Solutions 3 (12) (sol12)**.

Now, add a 1D plot group for the temperature.

#### *Temperature at Central Line for $k = 5$*

- 1 In the **Results** toolbar, click  **ID Plot Group**.
- 2 In the **Settings** window for **ID Plot Group**, type **Temperature at Central Line for  $k = 5$**  in the **Label** text field.
- 3 Click to expand the **Title** section. From the **Title type** list, choose **Manual**.

4 In the **Title** text area, type **Temperature at Central Line**.

*Line Graph 1*

- 1 In the **Temperature at Central Line for k = 5** toolbar, click  **Line Graph**.
- 2 In the **Settings** window for **Line Graph**, locate the **Data** section.
- 3 From the **Dataset** list, choose **Cut Line 3D 1**.
- 4 From the **Parameter selection (k)** list, choose **First**.
- 5 From the **Time selection** list, choose **Last**.
- 6 Click to expand the **Legends** section. From the **Legends** list, choose **Manual**.
- 7 Select the **Show legends** checkbox.
- 8 In the table, enter the following settings:

---

**Legends**

---

DOM

---

- 9 In the **Temperature at Central Line for k = 5** toolbar, click  **Plot**.

*Line Graph 2*

- 1 Right-click **Line Graph 1** and choose **Duplicate**.
- 2 In the **Settings** window for **Line Graph**, locate the **Data** section.
- 3 From the **Dataset** list, choose **Cut Line 3D 2**.
- 4 Locate the **Legends** section. In the table, enter the following settings:

---

**Legends**

---

P1

---

*Line Graph 3*

- 1 Right-click **Line Graph 2** and choose **Duplicate**.
- 2 In the **Settings** window for **Line Graph**, locate the **Data** section.
- 3 From the **Dataset** list, choose **Cut Line 3D 3**.
- 4 Locate the **Legends** section. In the table, enter the following settings:

---

**Legends**

---

Roseland

---

- 5 In the **Temperature at Central Line for k = 5** toolbar, click  **Plot**.

*Temperature at Central Line for  $k = 5$*

Duplicate the plot group and change the dataset to  $k = 120$ .

*Temperature at Central Line for  $k = 120$*

- 1 In the **Model Builder** window, right-click **Temperature at Central Line for  $k = 5$**  and choose **Duplicate**.
- 2 In the **Settings** window for **ID Plot Group**, type **Temperature at Central Line for  $k = 120$**  in the **Label** text field.

*Line Graph 1*

- 1 In the **Model Builder** window, expand the **Temperature at Central Line for  $k = 120$**  node, then click **Line Graph 1**.
- 2 In the **Settings** window for **Line Graph**, locate the **Data** section.
- 3 From the **Parameter selection (k)** list, choose **Last**.

*Line Graph 2*

- 1 In the **Model Builder** window, click **Line Graph 2**.
- 2 In the **Settings** window for **Line Graph**, locate the **Data** section.
- 3 From the **Parameter selection (k)** list, choose **Last**.

*Line Graph 3*

- 1 In the **Model Builder** window, click **Line Graph 3**.
- 2 In the **Settings** window for **Line Graph**, locate the **Data** section.
- 3 From the **Parameter selection (k)** list, choose **Last**.
- 4 In the **Temperature at Central Line for  $k = 120$**  toolbar, click  **Plot**.

The plots are shown in [Figure 2](#) and [Figure 3](#). For high optical thicknesses, the Rosseland approximation better represents the overall temperature distribution, whereas the P1 approximation is appropriate for lower optical thicknesses.