



Model created in COMSOL Multiphysics 6.4

Forced Convection Cooling of an Enclosure with Fan and Grille

The bottom of the box represents the printed circuit board (PCB). It has an anisotropic thermal conductivity of 10, 10, and 0.36 W/(m·K) along the x -, y -, and z -axes, respectively. Its density is 430 kg/m³ and its heat capacity at constant pressure is 1100 J/(kg·K). Because the thermal conductivity along the z -axis is relatively low, and that the PCB and the enclosure sides are separated by a thin air layer, it is not necessary to model the bottom wall, nor take into account the cooling on these sides.

The capacitors are approximated by aluminum components. The heat sink fins and the enclosure are made of the same aluminum alloy. The inductors are mainly composed of steel cores and copper coils. The transformers are made of three materials: copper, steel, and plastic. The transistors are modeled as two-domain components: a core made of silicon held in a plastic case. The core is in contact with an aluminum heat sink to allow a more efficient heat transfer. The airflow is considered as turbulent and is modeled using the Algebraic y Plus turbulence model.

The simulated PSU consumes a maximum of 230 W. Components have been grouped and assigned to various heat sources as listed in Table 1. The overall heat loss is 41 W, which is about 82% of efficiency.

TABLE 1: HEAT SOURCES OF ELECTRONIC COMPONENTS.

Components	Dissipated heat rate (W)
Transistor cores	25
Large transformer coil	5
Small transformer coils	3
Inductors	2
Large capacitors	2
Medium capacitors	3
Small capacitors	1

The inlet air temperature is set at 30°C because it is supposed to come from the computer case in which air has already cooled other components. The inlet boundary is configured with a **Grille** boundary condition with **Perforated plate** option. This condition describes head loss caused by air entry into the enclosure and provides built-in correlation for the head loss coefficient k_{grille} :

$$k_{grille} = 0,94((1 - \sigma_s)^{-2} - 1)^{1,28} \quad (1)$$

where σ_s is the solidity of the grille. The head loss, ΔP (Pa), is given by

$$\Delta P = k_{\text{grille}} \frac{\rho V_0^2}{2}$$

where ρ is the density (kg/m^3), and V_0 is the flow rate (m^3/s).

The box, the PCB, the inductor surfaces, and the heat sink fins are configured as thin conductive layers.

Results and Discussion

The most interesting aspect of this simulation is to locate which components are subject to overheating. Figure 2 clearly shows that the temperature distribution is not homogeneous.

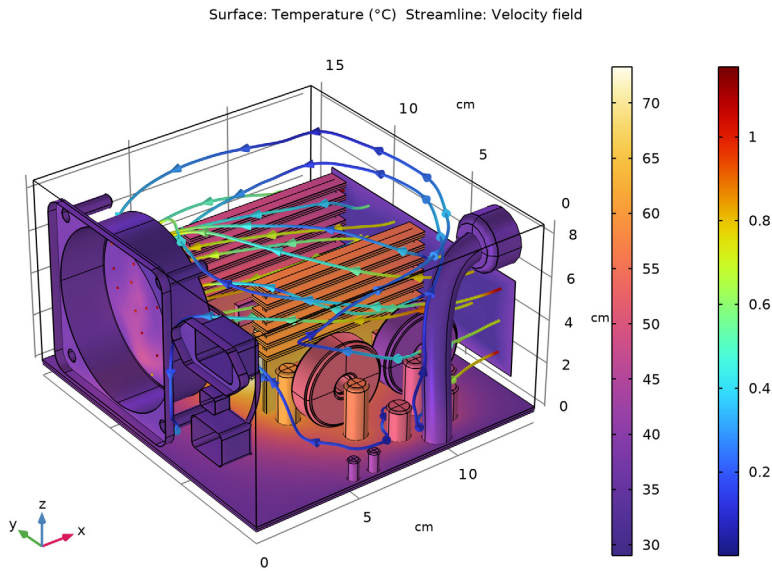

Figure 2: Temperature and fluid velocity fields.

The maximum temperature is about 73°C and is located at one of the transistor cores. The components furthest away from the air inlet are subject to the highest temperature. Although transistor cores are rather hot, Figure 2 shows that they are significantly cooled by the aluminum heat sinks. The printed circuit board has a significant impact as well by distributing and draining heat off.

On the flow side, air avoids obstacles and tends to go through the upper space of the enclosure. The maximum velocity is about 1.2 m/s.

Figure 3 shows the head loss created by obstacles encountered by air on its path.

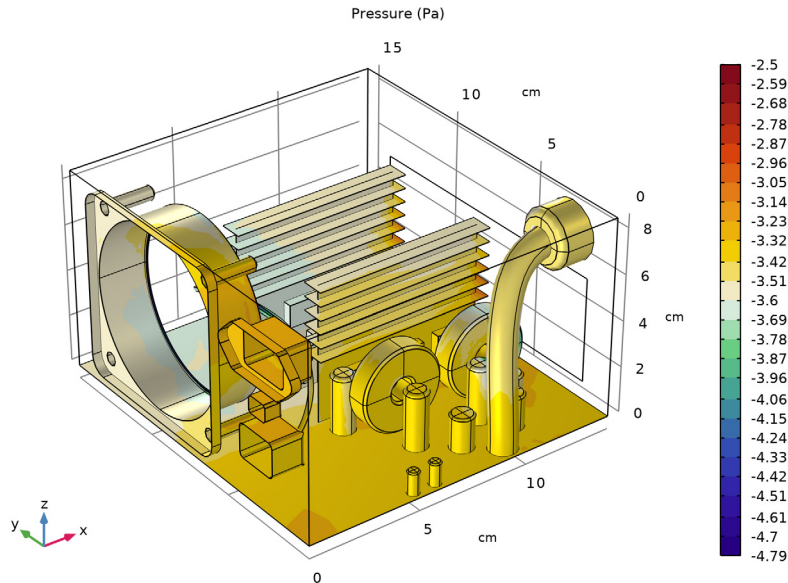

Figure 3: Pressure isosurfaces show the head loss created by electronic components.

As shown in Figure 3, the fluid flow is impacted by obstacles and yields to local head losses.

Notes About the COMSOL Implementation

To model heat sink fins, enclosure walls and circuit board it is strongly recommended to use the **Thin Layer** feature, which is completely adapted for thin geometries and significantly reduces the number of degrees of freedom in the model.

COMSOL Multiphysics provides a useful boundary condition for modeling fan behavior. You just need to provide a few points of a static pressure curve to configure this boundary condition. These data are, most of the time, provided by fan manufacturers.

Reference

1. R.D. Blevins, *Applied Fluid Dynamics Handbook*, Van Nostrand Reinhold, 1984.

Application Library path: Heat_Transfer_Module/
Power_Electronics_and_Electronic_Cooling/electronic_enclosure_cooling

Modeling Instructions

ROOT

The file `electronic_enclosure_cooling_geom.mph` contains a parameterized geometry and prepared selections for the model. Start by loading this file.

APPLICATION LIBRARIES

- 1 From the **File** menu, choose **Application Libraries**.
- 2 In the **Application Libraries** window, select **Heat Transfer Module** > **Power Electronics and Electronic Cooling** > **electronic_enclosure_cooling_geom** in the tree.
- 3 Click  **Open**.

ROOT

In the **Model Builder** window, click the root node.

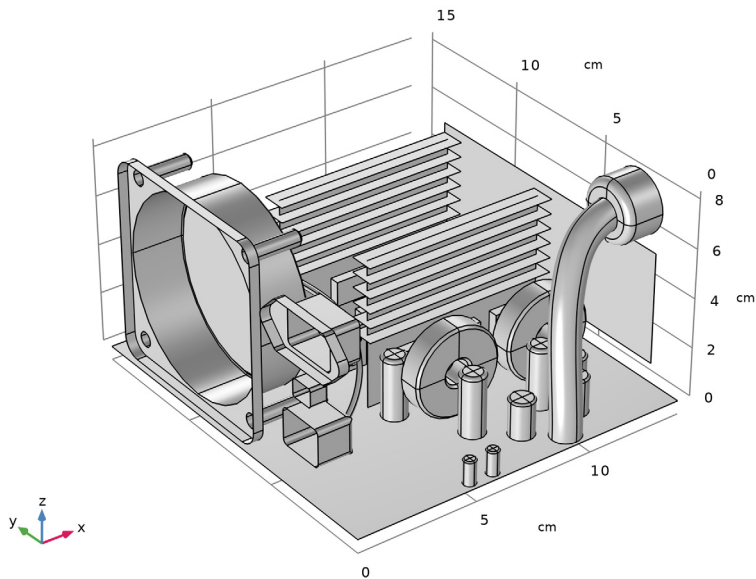

MATERIALS

In this section, you define the materials of the enclosure and its components. The prepared selections make it easier to select the appropriate domains and boundaries.

ADD MATERIAL

- 1 In the **Materials** toolbar, click  **Add Material** to open the **Add Material** window.
- 2 Go to the **Add Material** window.
- 3 In the tree, select **Built-in > Air**.
- 4 Click the **Add to Component** button in the window toolbar.
- 5 In the tree, select **Built-in > Acrylic plastic**.
- 6 Click the **Add to Component** button in the window toolbar.
- 7 In the tree, select **Built-in > Steel AISI 4340**.
- 8 Click the **Add to Component** button in the window toolbar.
- 9 In the tree, select **Built-in > Aluminum**.
- 10 Click the **Add to Component** button in the window toolbar.
- 11 In the tree, select **Built-in > Copper**.
- 12 Click the **Add to Component** button in the window toolbar.
- 13 In the tree, select **Built-in > Silicon**.
- 14 Click the **Add to Component** button in the window toolbar.
- 15 In the tree, select **Built-in > Aluminum 6063-T83**.
- 16 Click the **Add to Component** button in the window toolbar.
- 17 In the tree, select **Built-in > Copper**.
- 18 Click the **Add to Component** button in the window toolbar.
- 19 In the **Materials** toolbar, click  **Add Material** to close the **Add Material** window.

MATERIALS

Air (mat1)

- 1 In the **Settings** window for **Material**, locate the **Geometric Entity Selection** section.
- 2 From the **Selection** list, choose **Air**.

Acrylic plastic (mat2)

- 1 In the **Model Builder** window, click **Acrylic plastic (mat2)**.
- 2 In the **Settings** window for **Material**, locate the **Geometric Entity Selection** section.
- 3 From the **Selection** list, choose **Plastic**.

Steel AISI 4340 (mat3)

- 1 In the **Model Builder** window, click **Steel AISI 4340 (mat3)**.
- 2 In the **Settings** window for **Material**, locate the **Geometric Entity Selection** section.
- 3 From the **Selection** list, choose **Steel Parts**.

Aluminum (mat4)

- 1 In the **Model Builder** window, click **Aluminum (mat4)**.
- 2 In the **Settings** window for **Material**, locate the **Geometric Entity Selection** section.
- 3 From the **Selection** list, choose **Capacitors**.

Copper (mat5)

- 1 In the **Model Builder** window, click **Copper (mat5)**.
- 2 In the **Settings** window for **Material**, locate the **Geometric Entity Selection** section.
- 3 From the **Selection** list, choose **Transformer Coils**.

Silicon (mat6)

- 1 In the **Model Builder** window, click **Silicon (mat6)**.
- 2 In the **Settings** window for **Material**, locate the **Geometric Entity Selection** section.
- 3 From the **Selection** list, choose **Transistors Silicon Cores**.

Heat Sink

- 1 In the **Model Builder** window, under **Component 1 (comp1) > Materials** click **Aluminum 6063-T83 (mat7)**.
- 2 In the **Settings** window for **Material**, type Heat Sink in the **Label** text field.
- 3 Locate the **Geometric Entity Selection** section. From the **Geometric entity level** list, choose **Boundary**.
- 4 From the **Selection** list, choose **Aluminum Boundaries**.
- 5 Click to expand the **Material Properties** section. In the **Material properties** tree, select **Geometric Properties > Shell > Thickness (lth)**.
- 6 Click **+ Add to Material**.
- 7 Click to collapse the **Material Properties** section. Locate the **Material Contents** section. In the table, enter the following settings:

Property	Variable	Value	Unit	Property group
Thickness	lth	2 [mm]	m	Shell

Copper layers

- 1 In the **Model Builder** window, under **Component 1 (comp1) > Materials** click **Copper 1 (mat8)**.
- 2 In the **Settings** window for **Material**, type Copper layers in the **Label** text field.
- 3 Locate the **Geometric Entity Selection** section. From the **Geometric entity level** list, choose **Boundary**.
- 4 From the **Selection** list, choose **Copper Layers**.
- 5 Click to expand the **Material Properties** section. In the **Material properties** tree, select **Geometric Properties > Shell > Thickness (lth)**.
- 6 Click **+ Add to Material**.
- 7 Click to collapse the **Material Properties** section. Locate the **Material Contents** section. In the table, enter the following settings:

Property	Variable	Value	Unit	Property group
Thickness	lth	2 [mm]	m	Shell

FR4 (Circuit Board)

- 1 In the **Model Builder** window, right-click **Materials** and choose **Blank Material**.
- 2 In the **Settings** window for **Material**, type FR4 (Circuit Board) in the **Label** text field.
- 3 Locate the **Geometric Entity Selection** section. From the **Geometric entity level** list, choose **Boundary**.
- 4 From the **Selection** list, choose **Circuit Board**.
- 5 Click to expand the **Material Properties** section. In the **Material properties** tree, select **Geometric Properties > Shell > Thickness (lth)**.
- 6 Click **+ Add to Material**.
- 7 In the **Material properties** tree, select **Basic Properties > Heat Capacity at Constant Pressure**.
- 8 Click **+ Add to Material**.
- 9 In the **Material properties** tree, select **Basic Properties > Density**.
- 10 Click **+ Add to Material**.
- 11 In the **Material properties** tree, select **Basic Properties > Thermal Conductivity**.
- 12 Click **+ Add to Material**.

13 Click to collapse the **Material Properties** section. Locate the **Material Contents** section. In the table, enter the following settings:

Property	Variable	Value	Unit	Property group
Thickness	lth	2 [mm]	m	Shell
Heat capacity at constant pressure	Cp	1369 [J / (kg* K)]	J/(kg·K)	Basic
Density	rho	1900 [kg/m^3]	kg/m ³	Basic

14 Right-click the **Thermal conductivity** row and choose **Edit**.

15 In the **Thermal conductivity** dialog, choose **Diagonal** from the list.

16 In the table, enter the following settings:

10 [W/ (m*K)]	0	0
0	10 [W/ (m*K)]	0
0	0	0.3 [W/ (m*K)]

17 Click **OK**.

The next steps define the boundary conditions of the model.

DEFINITIONS (COMPI)

Ambient Properties 1 (ampr1)

1 In the **Model Builder** window, expand the **Component 1 (comp1) > Heat Transfer in Solids and Fluids (ht)** node.

2 Right-click **Component 1 (comp1) > Definitions** and choose **Shared Properties > Ambient Properties**.

Set the ambient temperature to be used in initial values of the Heat Transfer interface.

3 In the **Settings** window for **Ambient Properties**, locate the **Ambient Conditions** section.

4 In the T_{amb} text field, type 30[degC].

HEAT TRANSFER IN SOLIDS AND FLUIDS (HT)

Fluid 1

1 In the **Model Builder** window, under **Component 1 (comp1) > Heat Transfer in Solids and Fluids (ht)** click **Fluid 1**.

2 In the **Settings** window for **Fluid**, locate the **Domain Selection** section.

3 From the **Selection** list, choose **Air**.

Initial Values 1

- 1 In the **Model Builder** window, click **Initial Values 1**.
- 2 In the **Settings** window for **Initial Values**, locate the **Initial Values** section.
- 3 From the T list, choose **Ambient temperature (ampri)**.

Now, define the heat rate produced by the different components. [Table 1](#) summarizes the values chosen for each kind of component.

Heat Source 1: Transistors

- 1 In the **Physics** toolbar, click  **Domains** and choose **Heat Source**.
- 2 In the **Settings** window for **Heat Source**, type Heat Source 1: Transistors in the **Label** text field.
- 3 Locate the **Domain Selection** section. From the **Selection** list, choose **Transistors Silicon Cores**.
- 4 Locate the **Heat Source** section. From the **Heat source** list, choose **Heat rate**.
- 5 In the P_0 text field, type 25[W].

Heat Source 2: Large Transformer Coil

- 1 In the **Physics** toolbar, click  **Domains** and choose **Heat Source**.
- 2 In the **Settings** window for **Heat Source**, type Heat Source 2: Large Transformer Coil in the **Label** text field.
- 3 Locate the **Domain Selection** section. From the **Selection** list, choose **Large Transformer Coil**.
- 4 Locate the **Heat Source** section. From the **Heat source** list, choose **Heat rate**.
- 5 In the P_0 text field, type 5[W].

Heat Source 3: Small Transformer Coils

- 1 In the **Physics** toolbar, click  **Domains** and choose **Heat Source**.
- 2 In the **Settings** window for **Heat Source**, type Heat Source 3: Small Transformer Coils in the **Label** text field.
- 3 Locate the **Heat Source** section. From the **Heat source** list, choose **Heat rate**.
- 4 In the P_0 text field, type 3[W].
- 5 Locate the **Domain Selection** section. From the **Selection** list, choose **Small Transformer Coils**.

Heat Source 4: Inductor

- 1 In the **Physics** toolbar, click  **Domains** and choose **Heat Source**.

- 2 In the **Settings** window for **Heat Source**, type Heat Source 4: Inductor in the **Label** text field.
- 3 Locate the **Domain Selection** section. From the **Selection** list, choose **Inductors**.
- 4 Locate the **Heat Source** section. From the **Heat source** list, choose **Heat rate**.
- 5 In the P_0 text field, type 2[W].

Heat Source 5: Large Capacitors

- 1 In the **Physics** toolbar, click  **Domains** and choose **Heat Source**.
- 2 In the **Settings** window for **Heat Source**, type Heat Source 5: Large Capacitors in the **Label** text field.
- 3 Locate the **Domain Selection** section. From the **Selection** list, choose **Large Capacitors**.
- 4 Locate the **Heat Source** section. From the **Heat source** list, choose **Heat rate**.
- 5 In the P_0 text field, type 2[W].

Heat Source 6: Medium Capacitors

- 1 In the **Physics** toolbar, click  **Domains** and choose **Heat Source**.
- 2 In the **Settings** window for **Heat Source**, type Heat Source 6: Medium Capacitors in the **Label** text field.
- 3 Locate the **Domain Selection** section. From the **Selection** list, choose **Medium Capacitors**.
- 4 Locate the **Heat Source** section. From the **Heat source** list, choose **Heat rate**.
- 5 In the P_0 text field, type 3[W].

Heat Source 7: Small Capacitors

- 1 In the **Physics** toolbar, click  **Domains** and choose **Heat Source**.
- 2 In the **Settings** window for **Heat Source**, type Heat Source 7: Small Capacitors in the **Label** text field.
- 3 Locate the **Domain Selection** section. From the **Selection** list, choose **Small Capacitors**.
- 4 Locate the **Heat Source** section. From the **Heat source** list, choose **Heat rate**.
- 5 In the P_0 text field, type 1[W].

Inflow 1

- 1 In the **Physics** toolbar, click  **Boundaries** and choose **Inflow**.
- 2 In the **Settings** window for **Inflow**, locate the **Boundary Selection** section.
- 3 From the **Selection** list, choose **Grille**.
- 4 Locate the **Upstream Properties** section. From the T_{ustr} list, choose **Ambient temperature (ampr1)**.

Thin Layer 1

- 1 In the **Physics** toolbar, click  **Boundaries** and choose **Thin Layer**.
- 2 In the **Settings** window for **Thin Layer**, locate the **Boundary Selection** section.
- 3 From the **Selection** list, choose **Conductive Layers**.
- 4 Locate the **Layer Model** section. From the **Layer type** list, choose **Thermally thin approximation**.

Outflow 1

- 1 In the **Physics** toolbar, click  **Boundaries** and choose **Outflow**.
- 2 In the **Settings** window for **Outflow**, locate the **Boundary Selection** section.
- 3 From the **Selection** list, choose **Fan**.

TURBULENT FLOW, ALGEBRAIC YPLUS (SPF)

- 1 In the **Model Builder** window, under **Component 1 (comp1)** click **Turbulent Flow, Algebraic yPlus (spf)**.
- 2 In the **Settings** window for **Turbulent Flow, Algebraic yPlus**, locate the **Domain Selection** section.
- 3 From the **Selection** list, choose **Air**.
- 4 Locate the **Turbulence** section. From the **Wall treatment** list, choose **Low Re**.

The thin heat sink fins are represented by interior boundaries in the geometry. An interior wall condition is used to prevent the fluid from flowing through these boundaries.

Interior Wall 1

- 1 In the **Physics** toolbar, click  **Boundaries** and choose **Interior Wall**.
- 2 In the **Settings** window for **Interior Wall**, locate the **Boundary Selection** section.
- 3 From the **Selection** list, choose **Fins**.

Fan 1

- 1 In the **Physics** toolbar, click  **Boundaries** and choose **Fan**.
- 2 In the **Settings** window for **Fan**, locate the **Boundary Selection** section.
- 3 From the **Selection** list, choose **Fan**.

4 Locate the **Flow Direction** section. From the **Flow direction** list, choose **Outlet**.

The **Graphics** window displays an arrow indicating the orientation of the flow through the fan. Compare with the figure below.

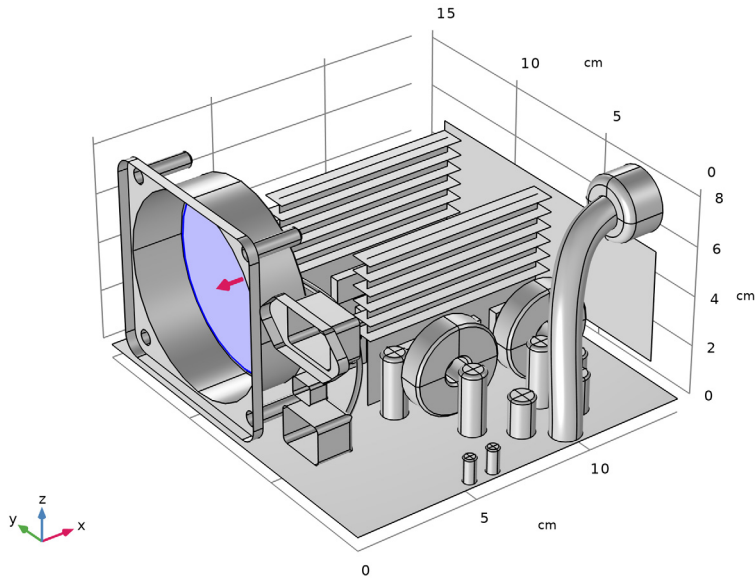

Here, the **Fan** condition is set up by loading a data file for the static pressure curve.

5 Locate the **Parameters** section. From the **Flow condition** list, choose **Static pressure curve, data**.

6 Locate the **Static Pressure Curve Data** section. Click  **Load from File**.

7 Browse to the model's Application Libraries folder and double-click the file `electronic_enclosure_cooling_fan_curve.txt`.

8 Locate the **Static Pressure Curve Interpolation** section. From the **Interpolation function type** list, choose **Piecewise cubic**.

The exhaust fan previously defined extracts air entering from an opposite grille. Proceed to create the corresponding boundary condition.

Grille 1

1 In the **Physics** toolbar, click  **Boundaries** and choose **Grille**.

2 In the **Settings** window for **Grille**, locate the **Boundary Selection** section.

3 From the **Selection** list, choose **Grille**.

- 4 Locate the **Parameters** section. From the **Flow condition** list, choose **Grille type**.
- 5 From the **Grille type** list, choose **Perforated plate**.
- 6 In the σ_s text field, type σ_g .

Initial Values I

- 1 In the **Model Builder** window, click **Initial Values I**.
- 2 In the **Settings** window for **Initial Values**, locate the **Initial Values** section.
- 3 Specify the **u** vector as

-1 [m/s]	x
----------	---

MESH I

Now configure the meshing part. Start by discretizing the surfaces of key components. They would drive the tetrahedral mesh of the whole domain. Boundary layers at walls are added at the end.

Mapped I

In the **Mesh** toolbar, click  **More Generators** and choose **Mapped**.

Size

- 1 In the **Model Builder** window, click **Size**.
- 2 In the **Settings** window for **Size**, locate the **Element Size** section.
- 3 From the **Predefined** list, choose **Coarse**.

Mapped I

- 1 In the **Model Builder** window, click **Mapped I**.
- 2 In the **Settings** window for **Mapped**, locate the **Boundary Selection** section.
- 3 From the **Selection** list, choose **Wire Group Surface**.
- 4 Click to expand the **Reduce Element Skewness** section. In order to get a regular mesh, select the option to adjust the mesh position on the edges in the swept direction.
- 5 Select the **Adjust edge mesh** checkbox.

Size I

- 1 Right-click **Mapped I** and choose **Size**.
- 2 In the **Settings** window for **Size**, locate the **Element Size** section.
- 3 From the **Predefined** list, choose **Finer**.
- 4 Click the **Custom** button.
- 5 Locate the **Element Size Parameters** section.

- 6 Select the **Maximum element size** checkbox. In the associated text field, type 0.5.
- 7 Select the **Minimum element size** checkbox. In the associated text field, type 0.4.
- 8 Click  **Build Selected**.

Mapped 2

- 1 In the **Mesh** toolbar, click  **More Generators** and choose **Mapped**.
- 2 In the **Settings** window for **Mapped**, locate the **Boundary Selection** section.
- 3 From the **Selection** list, choose **Small Wire Surface**.
- 4 Locate the **Reduce Element Skewness** section. Select the **Adjust edge mesh** checkbox.

Size 1

- 1 Right-click **Mapped 2** and choose **Size**.
- 2 In the **Settings** window for **Size**, locate the **Element Size** section.
- 3 From the **Calibrate for** list, choose **Fluid dynamics**.
- 4 From the **Predefined** list, choose **Extra fine**.
- 5 Click the **Custom** button.
- 6 Locate the **Element Size Parameters** section.
- 7 Select the **Maximum element size** checkbox. In the associated text field, type 0.15.

8 Click  **Build Selected**.

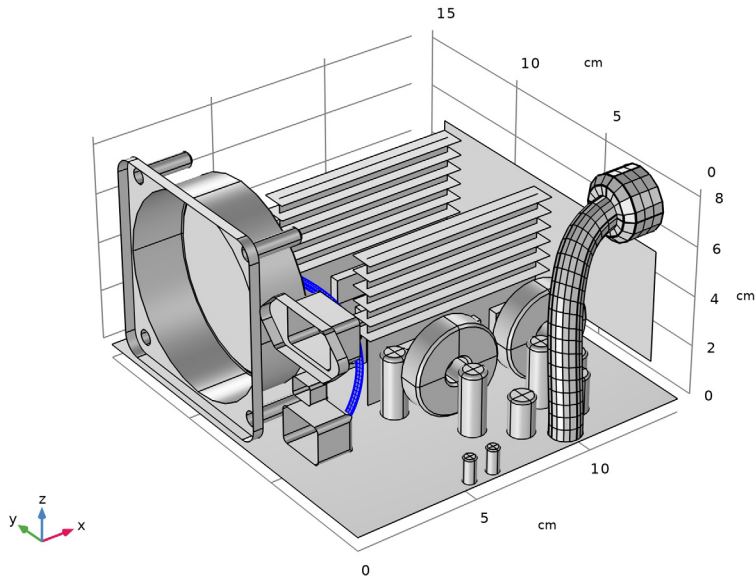

Free Triangular I

- 1 In the **Mesh** toolbar, click  **More Generators** and choose **Free Triangular**.
- 2 In the **Settings** window for **Free Triangular**, locate the **Boundary Selection** section.
- 3 From the **Selection** list, choose **Heat Exchange Surface**.

Size I

- 1 Right-click **Free Triangular I** and choose **Size**.
- 2 In the **Settings** window for **Size**, locate the **Element Size** section.
- 3 Click the **Custom** button.
- 4 Locate the **Element Size Parameters** section.
- 5 Select the **Maximum element size** checkbox. In the associated text field, type 0.5.
- 6 Select the **Minimum element size** checkbox. In the associated text field, type 0.4.
- 7 Select the **Maximum element growth rate** checkbox. In the associated text field, type 1.05.
- 8 Select the **Curvature factor** checkbox. In the associated text field, type 1.
- 9 Select the **Resolution of narrow regions** checkbox. In the associated text field, type 1.
- 10 Click  **Build Selected**.

Free Triangular 2

- 1 In the **Mesh** toolbar, click  **More Generators** and choose **Free Triangular**.
- 2 In the **Settings** window for **Free Triangular**, locate the **Boundary Selection** section.
- 3 From the **Selection** list, choose **Curved Area**.

Size 1

- 1 Right-click **Free Triangular 2** and choose **Size**.
- 2 In the **Settings** window for **Size**, locate the **Element Size** section.
- 3 From the **Calibrate for** list, choose **Fluid dynamics**.
- 4 Click  **Build Selected**.

Free Tetrahedral 1

In the **Mesh** toolbar, click  **Free Tetrahedral**.

Boundary Layers 1

- 1 In the **Mesh** toolbar, click  **Boundary Layers**.
- 2 In the **Settings** window for **Boundary Layers**, locate the **Geometric Entity Selection** section.
- 3 From the **Geometric entity level** list, choose **Domain**.
- 4 From the **Selection** list, choose **Air**.
- 5 Click to expand the **Corner Settings** section. From the **Handling of sharp edges** list, choose **Trimming**.

Boundary Layer Properties

- 1 In the **Model Builder** window, click **Boundary Layer Properties**.
- 2 In the **Settings** window for **Boundary Layer Properties**, locate the **Boundary Selection** section.
- 3 From the **Selection** list, choose **Walls**.
- 4 Locate the **Layers** section. In the **Number of layers** text field, type 3.

5 Click  **Build All**.

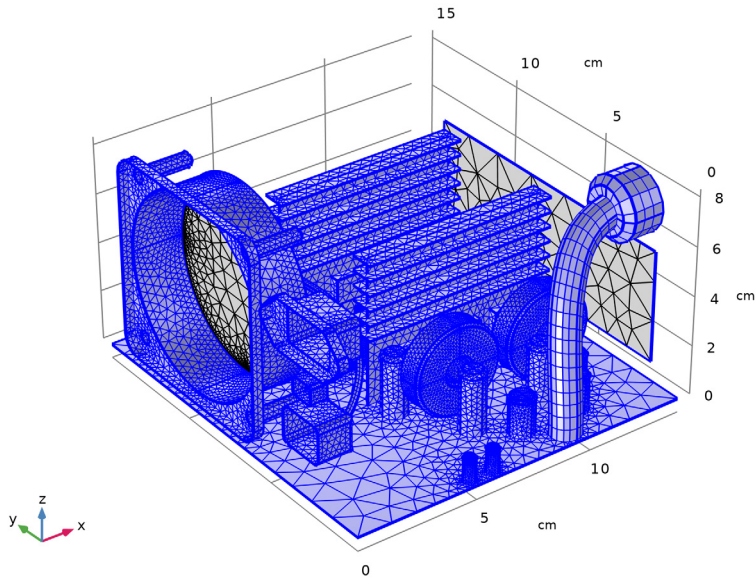



STUDY I

In the **Study** toolbar, click  **Compute**.

RESULTS

Change the unit of the temperature results to degrees Celsius.

Preferred Units I

- 1 In the **Results** toolbar, click  **Configurations** and choose **Preferred Units**.
- 2 In the **Settings** window for **Preferred Units**, locate the **Units** section.
- 3 Click  **Add Physical Quantity**.
- 4 In the **Physical Quantity** dialog, select **General > Temperature (K)** in the tree.
- 5 Click **OK**.
- 6 In the **Settings** window for **Preferred Units**, locate the **Units** section.
- 7 In the table, enter the following settings:

Quantity	Unit	Preferred unit
Temperature	K	°C

8 Click  **Apply**.

Temperature (ht)

The first default plot shows the temperature field. To reproduce the plot in [Figure 2](#) of the temperature and the air velocity, proceed as follows.

Domain

- 1 In the **Model Builder** window, expand the **Temperature (ht)** node.
- 2 Right-click **Domain** and choose **Delete**.

Layered Shell

- 1 In the **Settings** window for **Volume**, locate the **Coloring and Style** section.
- 2 From the **Color table** list, choose **HeatCameraLight**.

Surface 1

- 1 In the **Model Builder** window, right-click **Temperature (ht)** and choose **Surface**.
- 2 In the **Settings** window for **Surface**, click to expand the **Title** section.
- 3 Click to expand the **Inherit Style** section. From the **Plot** list, choose **Layered Shell**.



Temperature (ht)

In the **Model Builder** window, click **Temperature (ht)**.

Streamline 1

- 1 In the **Temperature (ht)** toolbar, click  **Streamline**.
- 2 In the **Settings** window for **Streamline**, click **Replace Expression** in the upper-right corner of the **Expression** section. From the menu, choose **Component 1 (comp1) > Turbulent Flow, Algebraic yPlus > Velocity and pressure > u,v,w - Velocity field**.
- 3 Locate the **Selection** section. From the **Selection** list, choose **Grille**.
- 4 Locate the **Coloring and Style** section. Find the **Line style** subsection. From the **Type** list, choose **Tube**.
- 5 Find the **Point style** subsection. From the **Type** list, choose **Arrow**.

Color Expression 1

- 1 In the **Temperature (ht)** toolbar, click  **Color Expression**.
- 2 In the **Settings** window for **Color Expression**, click **Replace Expression** in the upper-right corner of the **Expression** section. From the menu, choose **Component 1 (comp1) > Turbulent Flow, Algebraic yPlus > Velocity and pressure > spf.U - Velocity magnitude - m/s**.
- 3 In the **Temperature (ht)** toolbar, click  **Plot**.

Velocity (spf)

The second default plot group shows the air velocity profile in a mutlislice plot.

Pressure (spf)

The third default plot group shows the pressure field.

Wall Resolution (spf)

The fourth default plot group shows the wall resolution on the concerned boundaries of the domain.

Temperature and Fluid Flow (nitfl)

The last default plot group shows the wall temperature along with the air velocity field within the enclosure.