



Model created in COMSOL Multiphysics 6.4

Double-Pipe Heat Exchanger

Introduction

A double-pipe heat exchanger consists of two concentric pipes often performing a U-turn. Due to low costs, it has a large range of applications especially in the chemical process industry. Another advantage is that it can operate at very high pressures. For different scopes, the double-pipe heat exchanger can be stacked in series.

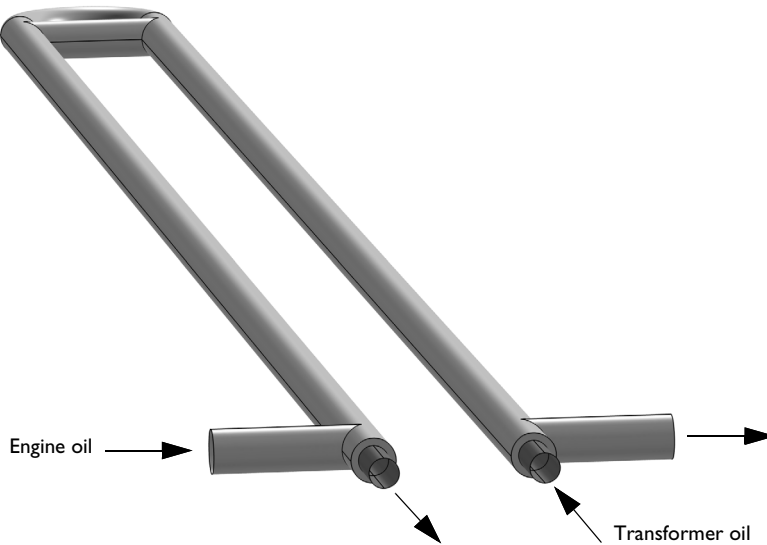

Figure 1: Geometry and concept of the double-pipe heat exchanger.

This tutorial shows how to efficiently model a double-pipe heat exchanger and focuses on preparing the geometry in order to build a suitable mesh manually. In addition, typical postprocessing options are shown.

Model Definition

The concept and basic geometry of the double-pipe heat exchanger is shown in [Figure 1](#). The heat exchanger is made of high tensile steel (Steel AISI 4340). The radii of the concentric pipes are 2.55 cm and 4.8 cm, while the overall length is about 6 m. Due to this high aspect ratio, the mesh has to be carefully handled.

Engine oil at 130°C flows through the outer pipe and is cooled by a transformer oil at 60°C, flowing in countercurrent through the inner pipe to prevent the engine oil from

overheating. The material properties of both oils depend on the temperature, and thus the Nonisothermal Flow predefined multiphysics coupling is used.

FLOW REGIME

To decide whether the flow is laminar or turbulent, estimate the Reynolds number beforehand. The Reynolds number for flows inside a pipe is defined as

$$\text{Re} = \frac{\rho v D_H}{\mu}$$

where ρ is the density of the fluid, v the typical velocity (taken as the inlet velocity), μ the viscosity, and D_H the hydraulic diameter. For the inner pipe, D_H is equal to the diameter of the pipe, and for the outer pipe it is the difference between the pipes radii. Adhere to the typical values in [Table 1](#) to evaluate Re .

TABLE 1: TYPICAL QUANTITIES FOR THE REYNOLDS NUMBER.

Quantity	Symbol	Inner pipe	Outer pipe
Density	ρ	850 kg/m ³	825 kg/m ³
Inlet velocity	v	0.205 m/s	0.09 m/s
Typical length	D_H	5.1 cm	1.3 cm
Dynamic viscosity	μ	5·10 ⁻³ Pa·s	1·10 ⁻³ Pa·s

The Reynolds numbers for the inner and outer pipes are about 1800 and 1000, respectively. Based on this approximation the Nonisothermal Flow multiphysics coupling in laminar regime is used.

Meanwhile, the densities of the two separated fluids can be considered constant thanks to small temperature variations in each of the inner and outer pipes. Both fluid flows can then be modeled by incompressible formulations.

BOUNDARY CONDITIONS

The body of the heat exchanger is modeled as a shell in 3D. This requires special boundary conditions for the flow and heat transport equations. The interior wall condition separates the pipes and applies a no slip condition for the flow on both sides.

To account for the in-plane heat flux in the shell, the **Thin Layer** boundary condition is applied. This boundary condition simulates heat transfer in thin shell structures. Here, the shell is made of steel with a 7 mm thickness.

The inlet boundary condition applies a laminar inflow profile at the pipe's ends. Refer to the *Heat Transfer Module User's Guide* for more information about the settings for this

boundary condition. The engine oil enters the outer pipe at 130°C and with an average velocity of 0.09 m/s. The transformer oil enters the inner pipe at 60°C and with an average velocity of 0.205 m/s.

The outlets are connected to pipes of same diameter. For this configuration, the **Suppress backflow** option in the **Outlet** feature is particularly suited.

At exterior boundaries, the model assumes thermal insulation because the losses to the outside are considered negligible.

Results and Discussion

Figure 2 shows the temperature distribution along the center plane. The transformer oil is heated up by 9.5°C to 69.5°C while the engine oil is cooled by 6.5°C to 122.5°C.

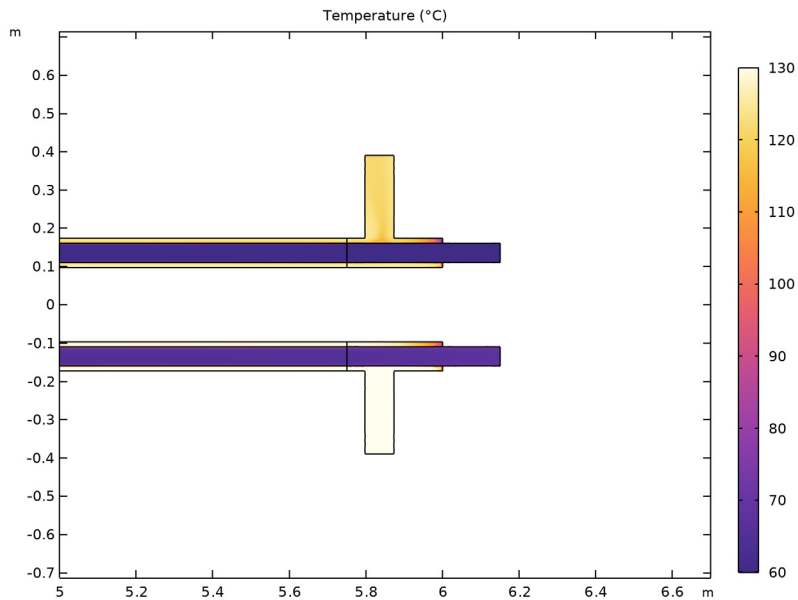

Figure 2: Temperature field in the central plane, zoomed at inlet and outlet regions.

The next plot shows the velocity field.

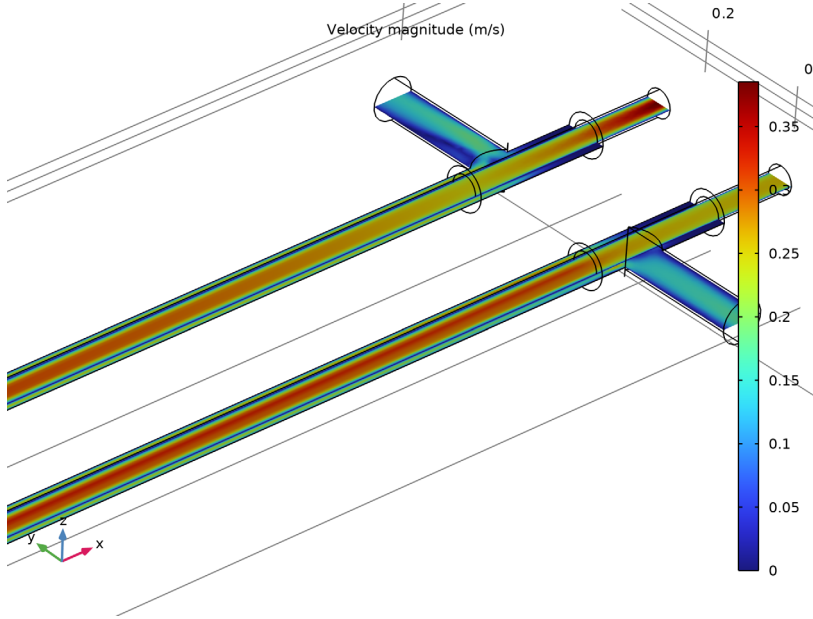

Figure 3: Velocity magnitude inside the pipes, zoomed at inlet and outlet regions.

The calculated pressure drops are close to 155 Pa for the inner pipe and close to 1350 Pa for the outer pipe.

The equivalent heat transfer coefficient describes the heat exchanger's performance. It is given by

$$h_{\text{eq}} = \frac{P}{A(T_{\text{hot}} - T_{\text{cold}})} \quad (1)$$

where P is the total exchanged power and A is the surface area of the interface between the two fluids. In this model the value of h_{eq} is about $42 \text{ W}/(\text{m}^2 \cdot \text{K})$.

Notes About the COMSOL Implementation

Setting up of the Nonisothermal Flow multiphysics coupling is straightforward according to the descriptions above. Due to the high nonlinearity in the model, initial values affect convergence. It is sufficient to set the initial temperature to $(T_{\text{hot}} + T_{\text{cold}})/2$.

Furthermore, the fluids that are considered incompressible would have densities equal to

a reference value, $\rho(T_{\text{ref}})$, taken at a reference temperature of T_{cold} at inner pipes and T_{hot} at outer pipes.

In this tutorial, using a physics-induced mesh leads to a large number of mesh elements. The long straight parts of the pipes can be meshed more efficiently with a swept mesh without losing accuracy. Therefore, the geometry needs to be divided into three parts: the U-turn, the straight parts, and the inlets/outlets (see Figure 4). The [Modeling Instructions](#) section below contains the steps for preparing and meshing the geometry as well as the postprocessing part.



Figure 4: Geometry of the double-pipe heat exchanger divided into three parts.

Application Library path: Heat_Transfer_Module/Heat_Exchangers/
double_pipe_heat_exchanger

Reference

1. H. S. Lee, *Thermal Design*, John Wiley & Sons, 2010.

Modeling Instructions

APPLICATION LIBRARIES

- 1 From the **File** menu, choose **Application Libraries**.
- 2 In the **Application Libraries** window, select **Heat Transfer Module > Heat Exchangers > double_pipe_heat_exchanger_preset** in the tree.
- 3 Click  **Open**.

COMPONENT 1 (COMPI)

To evaluate the equivalent heat transfer coefficient after the simulation, define a nonlocal integration coupling over the interior walls.

DEFINITIONS (COMPI)

Average Over Interior Wall

- 1 In the **Definitions** toolbar, click  **Nonlocal Couplings** and choose **Average**.
- 2 In the **Settings** window for **Average**, type Average Over Interior Wall in the **Label** text field.
- 3 Locate the **Source Selection** section. From the **Geometric entity level** list, choose **Boundary**.
- 4 From the **Selection** list, choose **Interior Walls**.

The physics-controlled mesh is suitable for fluid-flow models with boundary layers at all no-slip boundaries. The gradient along the pipes is expected to be very low compared to the gradient perpendicular to the pipe cross sections. Hence, a swept mesh is an appropriate choice for meshing the straight part of the pipes, reducing the computational costs while keeping accuracy. Before it is applicable, the geometry needs to be prepared to have the straight part of the pipes as separate domains. This can be done by partitioning the geometry with work planes. The predefined selections in **Component 1 > Definitions** ensure that the physical settings still apply to the correct entities, even after the partitioning operations.

GEOMETRY 1

Work Plane 1 (wp1)

- 1 In the **Geometry** toolbar, click  **Work Plane**.
- 2 In the **Settings** window for **Work Plane**, locate the **Plane Definition** section.
- 3 From the **Plane type** list, choose **Face parallel**.
- 4 On the object **imp1**, select Boundary 27 only.

It might be easier to select the correct boundary by using the **Selection List** window. To open this window, in the **Home** toolbar click **Windows** and choose **Selection List**. (If you are running the cross-platform desktop, you find **Windows** in the main menu.)

- 5 In the **Offset in normal direction** text field, type 0.4.
- 6 Select the **Reverse normal direction** checkbox.

Partition Objects 1 (par1)



- 1 In the **Geometry** toolbar, click  **Booleans and Partitions** and choose **Partition Objects**.

- 2 Select the object **imp1** only.
- 3 In the **Settings** window for **Partition Objects**, locate the **Partition Objects** section.
- 4 From the **Partition with** list, choose **Work plane**.

Work Plane 2 (wp2)

- 1 In the **Geometry** toolbar, click  **Work Plane**.
- 2 In the **Settings** window for **Work Plane**, locate the **Plane Definition** section.
- 3 From the **Plane type** list, choose **Face parallel**.
- 4 On the object **par1**, select Boundary 40 only.
- 5 In the **Offset in normal direction** text field, type 6.
- 6 Select the **Reverse normal direction** checkbox.

Partition Objects 2 (par2)

- 1 In the **Geometry** toolbar, click  **Booleans and Partitions** and choose **Partition Objects**.
- 2 Select the object **par1** only.
- 3 In the **Settings** window for **Partition Objects**, locate the **Partition Objects** section.
- 4 From the **Partition with** list, choose **Work plane**.
- 5 Click  **Build All Objects**.

The mesh can be set up. Start by the inlet and outlet parts, then sweep the mesh through the straight pipes. The U-turn again is meshed with free tetrahedral elements. The last step is to introduce the boundary-layer mesh at all no-slip walls.

MESH 1

Free Tetrahedral 1

In the **Mesh** toolbar, click  **Free Tetrahedral**.

Size

- 1 In the **Model Builder** window, click **Size**.
- 2 In the **Settings** window for **Size**, locate the **Element Size** section.
- 3 From the **Calibrate for** list, choose **Fluid dynamics**.
- 4 From the **Predefined** list, choose **Finer**.

Free Tetrahedral 1

- 1 In the **Model Builder** window, click **Free Tetrahedral 1**.
- 2 In the **Settings** window for **Free Tetrahedral**, locate the **Domain Selection** section.
- 3 From the **Geometric entity level** list, choose **Domain**.

4 Select Domains 7–10 only.

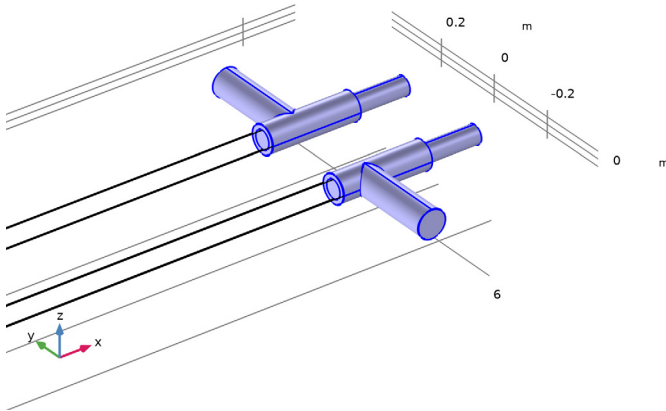

Size 1

- 1 In the **Mesh** toolbar, click **Size Attribute** and choose **Extra Fine**.
- 2 In the **Settings** window for **Size**, locate the **Geometric Entity Selection** section.
- 3 From the **Geometric entity level** list, choose **Boundary**.
- 4 Select Boundaries 27, 30, 33, and 36 only.
- 5 Locate the **Element Size** section. From the **Calibrate for** list, choose **Fluid dynamics**.
- 6 Click the **Custom** button.
- 7 Locate the **Element Size Parameters** section.
- 8 Select the **Maximum element size** checkbox. In the associated text field, type 0.009.
- 9 Click  **Build Selected**.

Swept 1

- 1 In the **Mesh** toolbar, click  **Swept**.
- 2 In the **Settings** window for **Swept**, locate the **Domain Selection** section.
- 3 From the **Geometric entity level** list, choose **Domain**.
- 4 Select Domains 3–6 only.

Distribution 1

- 1 Right-click **Swept 1** and choose **Distribution**.

- 2 In the **Settings** window for **Distribution**, locate the **Distribution** section.
- 3 From the **Distribution type** list, choose **Predefined**.
- 4 In the **Number of elements** text field, type 150.
- 5 In the **Element ratio** text field, type 5.
- 6 Select the **Symmetric distribution** checkbox.
- 7 Click  **Build Selected**.

Free Tetrahedral 2

- 1 In the **Mesh** toolbar, click  **Free Tetrahedral**.
- 2 In the **Settings** window for **Free Tetrahedral**, click  **Build Selected**.

Boundary Layers 1

In the **Mesh** toolbar, click  **Boundary Layers**.

In this geometry it is possible to generate the boundary layer elements without the corner splitting. This will result in a more homogeneous boundary layer mesh.

- 1 In the **Settings** window for **Boundary Layers**, click to expand the **Corner Settings** section.
- 2 From the **Handling of sharp edges** list, choose **No special handling**.
- 3 Click to expand the **Transition** section. Clear the **Smooth transition to interior mesh** checkbox.

Boundary Layer Properties

- 1 In the **Model Builder** window, click **Boundary Layer Properties**.
- 2 In the **Settings** window for **Boundary Layer Properties**, locate the **Geometric Entity Selection** section.
- 3 From the **Selection** list, choose **Steel Walls**.
- 4 Locate the **Layers** section. In the **Number of layers** text field, type 2.
- 5 In the **Thickness adjustment factor** text field, type 5.
- 6 Click  **Build All**.

STUDY 1

Change the nonlinear solver to get faster convergence.

Solution 1 (sol1)



- 1 In the **Study** toolbar, click  **Show Default Solver**.
- 2 In the **Model Builder** window, expand the **Solution 1 (sol1)** node.

- 3 In the **Model Builder** window, expand the **Study 1 > Solver Configurations > Solution 1 (sol1) > Stationary Solver 1** node, then click **Segregated 1**.
- 4 In the **Settings** window for **Segregated**, locate the **General** section.
- 5 From the **Stabilization and acceleration** list, choose **Anderson acceleration**.
- 6 In the **Model Builder** window, expand the **Study 1 > Solver Configurations > Solution 1 (sol1) > Stationary Solver 1 > AMG, fluid flow variables (spf)** node, then click **Multigrid 1**.
- 7 In the **Settings** window for **Multigrid**, locate the **General** section.
- 8 Select the **Compact aggregation** checkbox.
- 9 In the **Study** toolbar, click  **Compute**.

RESULTS

Change the unit of the temperature results to degrees Celsius.

Preferred Units 1

- 1 In the **Results** toolbar, click  **Configurations** and choose **Preferred Units**.
- 2 In the **Settings** window for **Preferred Units**, locate the **Units** section.
- 3 Click  **Add Physical Quantity**.
- 4 In the **Physical Quantity** dialog, select **General > Temperature (K)** in the tree.
- 5 Click **OK**.
- 6 In the **Settings** window for **Preferred Units**, locate the **Units** section.
- 7 In the table, enter the following settings:

Quantity	Unit	Preferred unit
Temperature	K	°C

- 8 Click  **Apply**.

Velocity (spf)

To create the plot shown in [Figure 3](#) change the settings of the default velocity plot. Begin by generating a dedicated view for the plot.

- 1 In the **Model Builder** window, under **Results** click **Velocity (spf)**.
- 2 In the **Settings** window for **3D Plot Group**, locate the **Plot Settings** section.
- 3 From the **View** list, choose **New view**.
- 4 In the **Velocity (spf)** toolbar, click  **Plot**.

Multislice 1



- 1 In the **Model Builder** window, expand the **Velocity (spf)** node, then click **Multislice 1**.
- 2 In the **Settings** window for **Multislice**, locate the **Multiplane Data** section.
- 3 Find the **x-planes** subsection. In the **Planes** text field, type 0.
- 4 Find the **y-planes** subsection. In the **Planes** text field, type 0.
- 5 In the **Velocity (spf)** toolbar, click  **Plot**.
- 6 Use the **Graphics** toolbox to get a satisfying view.

A 2D plot provides a better view of the temperature distribution along the pipes. Therefore, create a new dataset and use it for a 2D surface plot. [Figure 2](#) shows the temperature distribution in the center plane of the heat exchanger.



Cut Plane 1

- 1 In the **Results** toolbar, click  **Cut Plane**.
- 2 In the **Settings** window for **Cut Plane**, locate the **Plane Data** section.
- 3 From the **Plane** list, choose **xy-planes**.

Temperature (2D Center Plane)

- 1 In the **Results** toolbar, click  **2D Plot Group**.
- 2 In the **Settings** window for **2D Plot Group**, type Temperature (2D Center Plane) in the **Label** text field.
- 3 Locate the **Plot Settings** section. From the **View** list, choose **New view**.
- 4 In the **Temperature (2D Center Plane)** toolbar, click  **Plot** to generate the View node.

Surface 1

- 1 In the **Temperature (2D Center Plane)** toolbar, click  **Surface**.
- 2 In the **Settings** window for **Surface**, click **Replace Expression** in the upper-right corner of the **Expression** section. From the menu, choose **Component 1 (comp1) > Heat Transfer in Fluids > Temperature > T - Temperature - K**.
- 3 Locate the **Coloring and Style** section. From the **Color table** list, choose **HeatCameraLight**.
- 4 In the **Temperature (2D Center Plane)** toolbar, click  **Plot**.
- 5 Use the **Graphics** toolbox to get a satisfying view.

Heat Transfer Coefficient

The equivalent heat transfer coefficient can be calculated according to [Equation 1](#).

- 1 In the **Results** toolbar, click  **Global Evaluation**.

2 In the **Settings** window for **Global Evaluation**, type Heat Transfer Coefficient in the **Label** text field.

3 Locate the **Expressions** section. In the table, enter the following settings:

Expression	Unit	Description
aveop1(-ht.ntflux)/(T_hot-T_cold)	W/(m ² *K)	

4 Click **Evaluate** .

TABLE 1

1 Go to the **Table 1** window.

You should get around 42.5 W/(m²·K).

RESULTS

Evaluate the outlet temperatures and the pressure drops in the pipes.

Outlet Temperature, Transformer Oil

1 In the **Results** toolbar, click **More Derived Values** and choose **Average > Surface Average**.

2 In the **Settings** window for **Surface Average**, type Outlet Temperature, Transformer Oil in the **Label** text field.

3 Locate the **Selection** section. From the **Selection** list, choose **Inner Pipe, Outlet**.

4 Click **Replace Expression** in the upper-right corner of the **Expressions** section. From the menu, choose **Component 1 (comp1) > Heat Transfer in Fluids > Temperature > T - Temperature - K**.

5 Click **Evaluate** .

Outlet Temperature, Engine Oil

1 Right-click **Outlet Temperature, Transformer Oil** and choose **Duplicate**.

2 In the **Settings** window for **Surface Average**, type Outlet Temperature, Engine Oil in the **Label** text field.

3 Locate the **Selection** section. From the **Selection** list, choose **Outer Pipe, Outlet**.

4 Click **Evaluate** .

TABLE 2

1 Go to the **Table 2** window.

The transformer oil is heated up to 70°C while the engine oil is cooled to 123°C.

RESULTS

Inlet Pressure, Transformer Oil

- 1 In the **Results** toolbar, click 8.85×10^{-12} **More Derived Values** and choose **Average > Surface Average**.

The pressure drop is the difference between the inlet and outlet pressure. Because the pressure at the outlets is approximately zero, it is sufficient to calculate the inlet pressures.

- 2 In the **Settings** window for **Surface Average**, type Inlet Pressure, Transformer Oil in the **Label** text field.
- 3 Locate the **Selection** section. From the **Selection** list, choose **Inner Pipe, Inlet**.
- 4 Click **Replace Expression** in the upper-right corner of the **Expressions** section. From the menu, choose **Component 1 (comp1) > Laminar Flow > Velocity and pressure > p - Pressure - Pa**.
- 5 Click ∇ next to = Evaluate , then choose **New Table**.

Inlet Pressure, Engine Oil

- 1 Right-click **Inlet Pressure, Transformer Oil** and choose **Duplicate**.
- 2 In the **Settings** window for **Surface Average**, type Inlet Pressure, Engine Oil in the **Label** text field.
- 3 Locate the **Selection** section. From the **Selection** list, choose **Outer Pipe, Inlet**.
- 4 Click = Evaluate .

TABLE 3

- 1 Go to the **Table 3** window.

The pressure drop at the inner and outer pipes are close to 160 Pa and 1350 Pa, respectively.