



Model created in COMSOL Multiphysics 6.4

# Temperature Field in a Cooling Flange

## Introduction

---

Chemical reaction fluids can be cooled using glass flanges. The reaction fluid is passed through the flange and the air surrounding the flange then serves as the coolant. Engineers looking to optimize the cooling performance of such flanges can look to simulation for help.

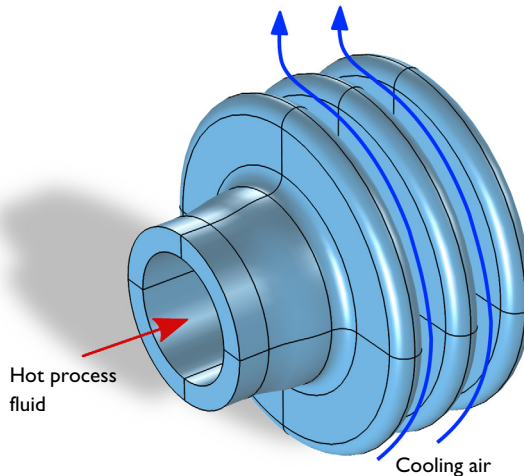

*Figure 1: Operating principle of the cooling flange.*

First off, the physics to analyze in this case is heat transfer, involving both convection and conduction. Heat transfer occurs via convection with both interior and exterior surfaces of the flange, and via conduction through the glass. The tube is heated from the inside by the process fluid, conduction then diffuses the heat in the flange, which in turn heats the air, causing a convective flow due to buoyancy effects. The cooling performance of the flange therefore depends on both convection and conduction.

To simplify the simulation convection cooling is analyzed using the heat transfer coefficient,  $h$ . Since this describes the fluid flow influence and the convective fluxes, the flow field does not have to be computed.

This particular example uses external research data ([Ref. 1](#)) for the outer surface heat transfer coefficient, which was originally obtained through semi-empirical data for natural

convection around a cylinder. For the tube-facing surface a coefficient for forced convection in a tube is used.

### *Model Definition*

---

Figure 2 presents the modeled geometry.

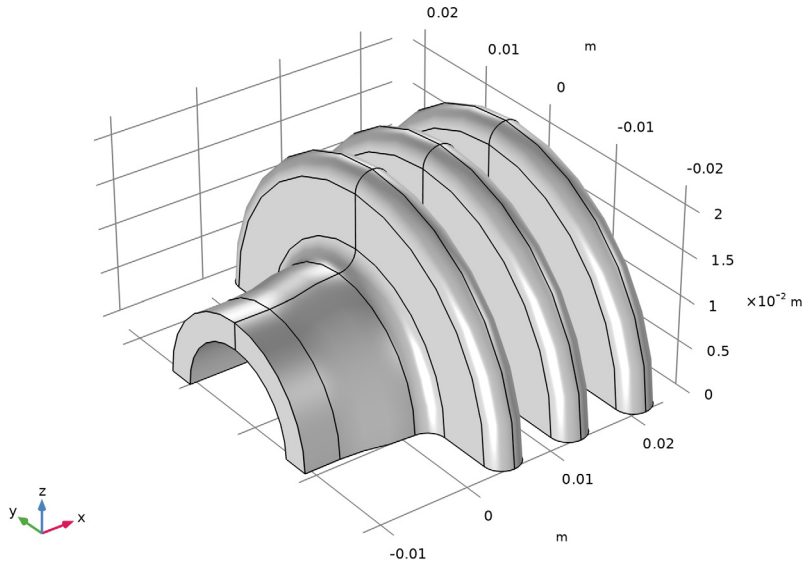

*Figure 2: Drawing of the cooling flange.*

The glass flange consists of a 4 mm thick pipe and 4 mm thick and 10 mm tall flanges, with a connecting pipe that has a 3 mm thick wall and an inner diameter of 16 mm. Note that in this tutorial, a parametric study on the pipe inner diameter is performed while the other dimensions remain fixed.

During operation, the hot process fluid heats the inside of the tube. The flange conducts the heat and transfers it to the surrounding air. As the air is heated, buoyancy effects cause a convective flow.

The heat transfer within the flange is described by the stationary heat equation

$$\nabla \cdot (-k \nabla T) = 0$$

where  $k$  is the thermal conductivity ( $W/(m \cdot K)$ ), and  $T$  is the temperature (K). On the flange's exterior boundaries, which face the air and process fluid, the applicable boundary condition is

$$-\mathbf{n} \cdot (-k \nabla T) = h(T_{\text{ext}} - T)$$

where  $\mathbf{n}$  is the normal vector of the boundary,  $h$ , is the heat transfer coefficient ( $W/(m^2 \cdot K)$ ), and  $T_{\text{inf}}$  is the temperature of the surrounding medium (K). For this simulation, set  $T_{\text{ext}}$  to 298 K for the cooling air and to 363 K for the process fluid.

You can approximate the value for the heat transfer coefficient,  $h$ , on the process fluid side with a constant value of  $15 W/(m^2 \cdot K)$  because the fluid's velocity is close to constant and the model assumes that its temperature decreases only slightly.

The  $h$  expression on the air side is more elaborate. Assume that the free-convection process around the flange is similar to that around a cylinder. The heat transfer coefficient for a cylinder is available in the literature (Ref. 1), and you can use the expression

$$h = \frac{k}{L} f(\theta) \text{Gr}^{1/4}$$

where  $k$  is the thermal conductivity of air ( $26.2 \text{ mW}/(m \cdot K)$  at 298 K);  $L$  is the typical length, which in this case is the outer diameter of the flange (44 mm); and  $f(\theta)$  is an empirical coefficient tabulated in Table 1 as a function of the incidence angle  $\theta$ , which is shown in Figure 3. Finally,  $\text{Gr}$  is the Grashof number defined as

$$\text{Gr} = \frac{g \alpha_p \Delta T L^3}{\nu^2}$$

where  $\alpha_p$  is the coefficient of thermal expansion ( $1/K$ ), which equals that for an ideal gas,  $g$  is the gravitational acceleration ( $9.81 \text{ m}/s^2$ ), and  $\nu$  is the kinematic viscosity ( $18 \cdot 10^{-6} \text{ m}^2/s$ ). For the flange material, use silica glass.

TABLE 1: EMPIRICAL TRANSFER COEFFICIENT VS. INCIDENCE ANGLE.

$\theta$ (DEG)	$f(\theta)$
0	0.48
90	0.46
100	0.45
110	0.435
120	0.42
130	0.38

TABLE 1: EMPIRICAL TRANSFER COEFFICIENT VS. INCIDENCE ANGLE.

$\theta$ (DEG)	$f(\theta)$
140	0.35
150	0.28
160	0.22
180	0.15

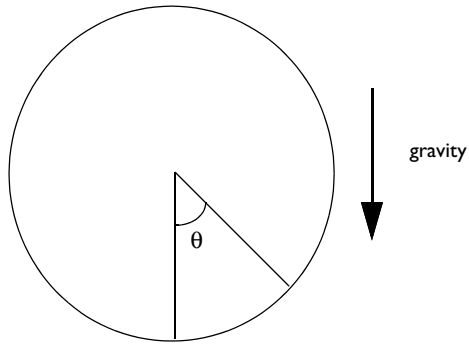

Figure 3: Definition of the incidence angle  $\theta$ .

## Results and Discussion

Figure 4 shows the flange surface temperature at steady state.

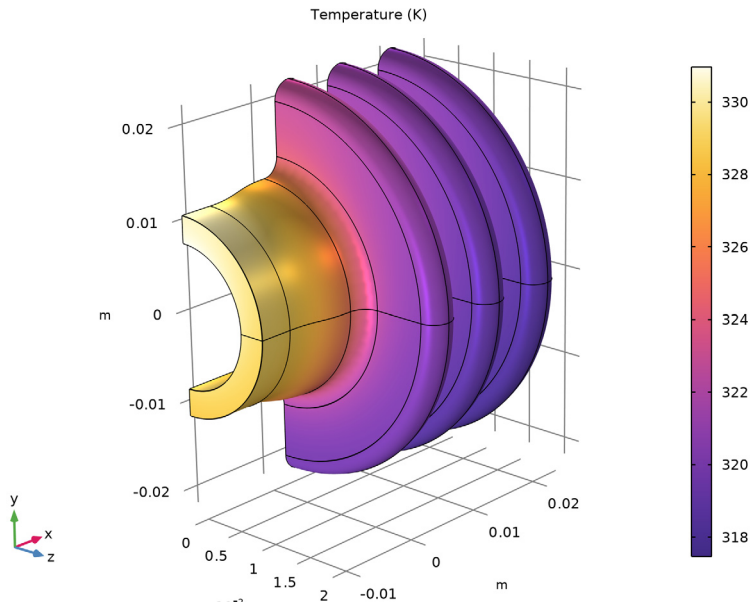

Figure 4: Stationary surface temperature of the flange.

As you can see in the surface temperature plot above to the left, the tube surface temperature is about 13 K higher than the flange shoulders. From the results, we can learn that the heat transfer from the outer surfaces of the flange is pretty efficient; there is a temperature difference of roughly 19 K between the outer flange surface and the air stream.

Figure 5 shows the heat transfer coefficient for the flange's outer walls.

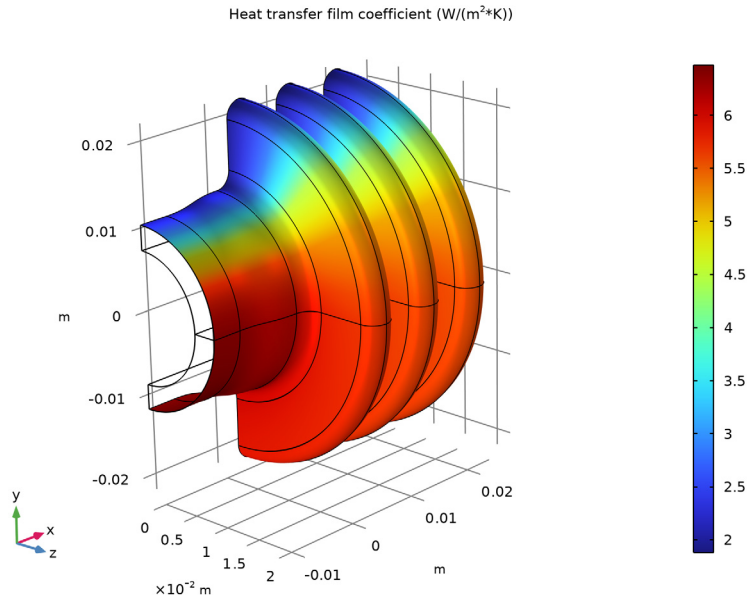

Figure 5: Heat transfer film coefficient,  $h$ , for the flange's outer walls.

As you can see, the coefficient decreases significantly along the vertical position of the flange's outer boundary.

Calculating the flange's total cooling power by integrating the normal total heat flux over the outer surfaces gives a value of 0.51 W which correspond to 1.02 W for the full geometry.

The surface temperature plot shown on Figure 4 further gives light to an inefficiency in the current flange design. When it enters the flange the process fluid is 363 K, while the inner surface of the pipe is only 32 K lower. Increasing the tube diameter would improve the heat transfer here, which is performed in a second stage of the modeling by varying the pipe's diameter, but keeping all other factors constant. By plotting in Figure 6 the global cooling power as a function of the inner pipe radius, you can now analyze how altering the radius impacts the performance of the cooling flange.

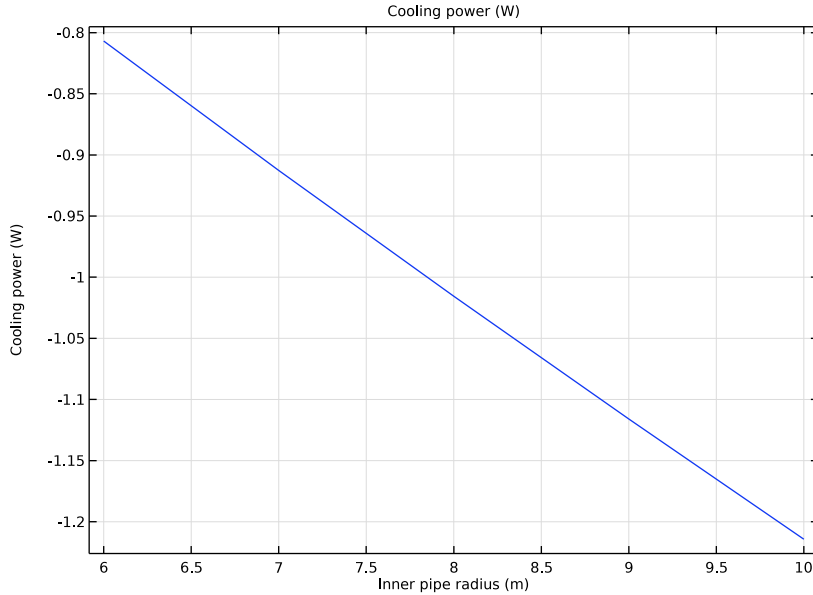

Figure 6: Total cooling power versus inner pipe radius.

### Reference

1. B. Sundén, *Kompendium i värmeöverföring [Notes on Heat Transfer]*, Sec. 10-3, Dept. of Heat and Power Engineering, Lund Inst. of Technology, 2003 (in Swedish).

**Application Library path:** Heat\_Transfer\_Module/Thermal\_Processing/cooling\_flange



### Modeling Instructions

From the **File** menu, choose **New**.

#### NEW

In the **New** window, click  **Model Wizard**.

## MODEL WIZARD

- 1 In the **Model Wizard** window, click  **3D**.
- 2 In the **Select Physics** tree, select **Heat Transfer > Heat Transfer in Solids (ht)**.
- 3 Click **Add**.
- 4 Click  **Study**.
- 5 In the **Select Study** tree, select **General Studies > Stationary**.
- 6 Click  **Done**.

## GLOBAL DEFINITIONS

### *Parameters 1*

Define parameters for relevant temperatures, material properties, and geometric dimensions. The parameters related to the geometry dimensions make it easier to perform parametric studies where you let some of these dimensions vary.

- 1 In the **Model Builder** window, under **Global Definitions** click **Parameters 1**.
- 2 In the **Settings** window for **Parameters**, locate the **Parameters** section.
- 3 In the table, enter the following settings:

Name	Expression	Value	Description
k	26.2[mW/(m*K)]	0.0262 W/(m·K)	Thermal conductivity, air
T_inner	363[K]	363 K	Temperature, process fluid
Hh	15[W/(m^2*K)]	15 W/(m <sup>2</sup> ·K)	Heat transfer coefficient
nu	18e-6[m^2/s]	1.8E-5 m <sup>2</sup> /s	Kinematic viscosity
r_inner	8[mm]	0.008 m	Inner pipe radius
l1	12[mm]	0.012 m	Pipe length excluding flanges
t1	3[mm]	0.003 m	Pipe thickness
t2	4[mm]	0.004 m	Pipe thickness, flange section
hf	10[mm]	0.01 m	Flange height
wf	4[mm]	0.004 m	Flange width
D	2*(r_inner+t2+hf)	0.044 m	Outer flange diameter

Next, create an interpolation function defined by the data in [Table 1](#).

*Interpolation 1 (int1)*

- 1 In the **Home** toolbar, click  $f(x)$  **Functions** and choose **Global > Interpolation**.
- 2 In the **Settings** window for **Interpolation**, locate the **Definition** section.
- 3 In the **Function name** text field, type  $f$ .
- 4 In the table, enter the following settings:

<b>t</b>	<b>f(t)</b>
0	0.48
90	0.46
100	0.45
110	0.435
120	0.42
130	0.38
140	0.35
150	0.28
160	0.22
180	0.15

- 5 Locate the **Units** section. In the **Argument** table, enter the following settings:

<b>Argument</b>	<b>Unit</b>
t	deg

- 6 In the **Function** table, enter the following settings:

<b>Function</b>	<b>Unit</b>
f	1

7 Click  **Plot**.

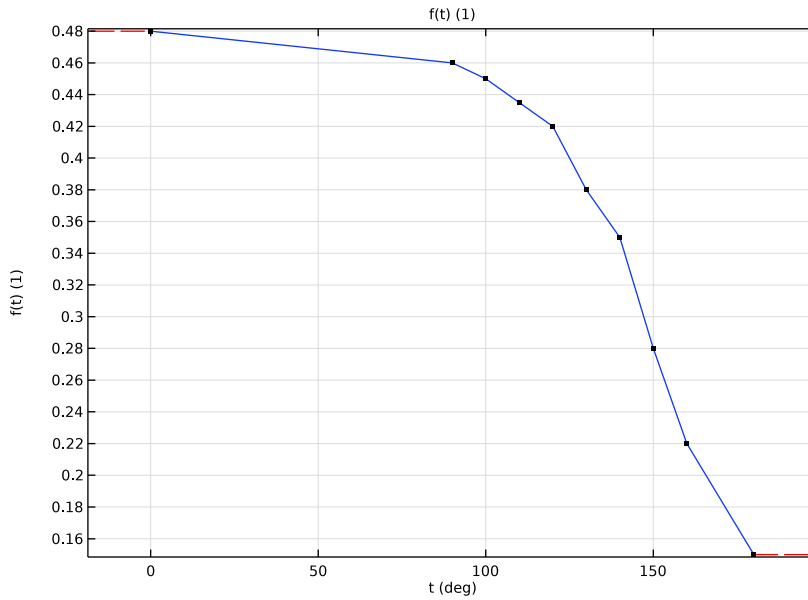

## GEOMETRY I

In a first geometry modeling stage, create a 2D geometry by following the steps below.

*Work Plane 1 (wp1)*

1 In the **Geometry** toolbar, click  **Work Plane**.

2 In the **Settings** window for **Work Plane**, click  **Go to Plane Geometry**.

*Work Plane 1 (wp1) > Plane Geometry*

In the **Model Builder** window, click **Plane Geometry**.

*Work Plane 1 (wp1) > Rectangle 1 (r1)*

1 In the **Work Plane** toolbar, click  **Rectangle**.

2 In the **Settings** window for **Rectangle**, locate the **Size and Shape** section.

3 In the **Width** text field, type  $2*wf$ .

4 In the **Height** text field, type  $t2$ .

5 Locate the **Position** section. In the **yw** text field, type  $r\_inner$ .

6 In the **Work Plane** toolbar, click  **Build All**.

7 Click the  **Zoom Extents** button in the **Graphics** toolbar.

*Work Plane 1 (wp1) > Quadratic Bézier 1 (qb1)*

- 1 In the **Work Plane** toolbar, click  **More Primitives** and choose **Quadratic Bézier**.
- 2 In the **Settings** window for **Quadratic Bézier**, locate the **Control Points** section.
- 3 In row **1**, set **yw** to  $r\_inner+t2$ .
- 4 In row **2**, set **xw** to  $wf/2$ , and **yw** to  $r\_inner+t2$ .
- 5 In row **3**, set **xw** to  $wf/2$ , and **yw** to  $r\_inner+t2+wf/2$ .

*Work Plane 1 (wp1) > Line Segment 1 (ls1)*

- 1 In the **Work Plane** toolbar, click  **More Primitives** and choose **Line Segment**.
- 2 In the **Settings** window for **Line Segment**, locate the **Starting Point** section.
- 3 From the **Specify** list, choose **Coordinates**.
- 4 Locate the **Endpoint** section. From the **Specify** list, choose **Coordinates**.
- 5 Locate the **Starting Point** section. In the **xw** text field, type  $wf/2$ .
- 6 Locate the **Endpoint** section. In the **xw** text field, type  $3*wf/2$ .
- 7 Locate the **Starting Point** section. In the **yw** text field, type  $r\_inner+t2+wf/2$ .
- 8 Locate the **Endpoint** section. In the **yw** text field, type  $r\_inner+t2+wf/2$ .



*Work Plane 1 (wp1) > Quadratic Bézier 2 (qb2)*

- 1 In the **Work Plane** toolbar, click  **More Primitives** and choose **Quadratic Bézier**.
- 2 In the **Settings** window for **Quadratic Bézier**, locate the **Control Points** section.
- 3 In row **1**, set **xw** to  $3*wf/2$ , and **yw** to  $r\_inner+t2+wf/2$ .
- 4 In row **2**, set **xw** to  $3*wf/2$ , and **yw** to  $r\_inner+t2$ .
- 5 In row **3**, set **xw** to  $2*wf$ , and **yw** to  $r\_inner+t2$ .



*Work Plane 1 (wp1) > Line Segment 2 (ls2)*

- 1 In the **Work Plane** toolbar, click  **More Primitives** and choose **Line Segment**.
- 2 In the **Settings** window for **Line Segment**, locate the **Starting Point** section.
- 3 From the **Specify** list, choose **Coordinates**.
- 4 Locate the **Endpoint** section. From the **Specify** list, choose **Coordinates**.
- 5 Locate the **Starting Point** section. In the **yw** text field, type  $r\_inner+t2$ .
- 6 Locate the **Endpoint** section. In the **xw** text field, type  $2*wf$ .
- 7 In the **yw** text field, type  $r\_inner+t2$ .
- 8 Drag and drop below **Quadratic Bézier 2 (qb2)**.



*Work Plane 1 (wp1) > Convert to Solid 1 (csol1)*

- 1 In the **Work Plane** toolbar, click  **Conversions** and choose **Convert to Solid**.
- 2 Select the objects **ls1**, **ls2**, **qb1**, and **qb2** only.
- 3 In the **Work Plane** toolbar, click  **Build All**.
- 4 Click the  **Zoom Extents** button in the **Graphics** toolbar.



*Work Plane 1 (wp1) > Rectangle 2 (r2)*

- 1 In the **Work Plane** toolbar, click  **Rectangle**.
- 2 In the **Settings** window for **Rectangle**, locate the **Size and Shape** section.
- 3 In the **Width** text field, type  $wf$ .
- 4 In the **Height** text field, type  $hf - wf$ .
- 5 Locate the **Position** section. In the **xw** text field, type  $wf / 2$ .
- 6 In the **yw** text field, type  $r\_inner + t2 + wf / 2$ .
- 7 In the **Work Plane** toolbar, click  **Build All**.
- 8 Click the  **Zoom Extents** button in the **Graphics** toolbar.

*Work Plane 1 (wp1) > Circle 1 (c1)*

- 1 In the **Work Plane** toolbar, click  **Circle**.
- 2 In the **Settings** window for **Circle**, locate the **Size and Shape** section.
- 3 In the **Radius** text field, type  $wf / 2$ .
- 4 In the **Sector angle** text field, type 180.
- 5 Locate the **Position** section. In the **xw** text field, type  $wf$ .
- 6 In the **yw** text field, type  $r\_inner + t2 + hf - wf / 2$ .
- 7 In the **Work Plane** toolbar, click  **Build All**.
- 8 Click the  **Zoom Extents** button in the **Graphics** toolbar.

*Work Plane 1 (wp1) > Array 1 (arr1)*

- 1 In the **Work Plane** toolbar, click  **Transforms** and choose **Array**.
- 2 Click in the **Graphics** window and then press **Ctrl+A** to select all objects.
- 3 In the **Settings** window for **Array**, locate the **Size** section.
- 4 From the **Array type** list, choose **Linear**.
- 5 In the **Size** text field, type 3.
- 6 Locate the **Displacement** section. In the **xw** text field, type  $2 * wf$ .
- 7 In the **Work Plane** toolbar, click  **Build All**.

8 Click the  **Zoom Extents** button in the **Graphics** toolbar.

*Work Plane 1 (wp1) > Polygon 1 (pol1)*

1 In the **Work Plane** toolbar, click  **Polygon**.

2 In the **Settings** window for **Polygon**, locate the **Object Type** section.

3 From the **Type** list, choose **Open curve**.

4 Locate the **Coordinates** section. From the **Data source** list, choose **Vectors**.

5 In the **xw** text field, type 0 0 -11 -11 -11 -11 -2\*11/3.

6 In the **yw** text field, type r\_inner+t2 r\_inner r\_inner r\_inner r\_inner+t1  
r\_inner+t1 r\_inner+t1.

*Work Plane 1 (wp1) > Cubic Bézier 1 (cb1)*

1 In the **Work Plane** toolbar, click  **More Primitives** and choose **Cubic Bézier**.

2 In the **Settings** window for **Cubic Bézier**, locate the **Control Points** section.

3 In row **1**, set **xw** to -2\*11/3, and **yw** to r\_inner+t2.

4 In row **2**, set **xw** to -11/3, and **yw** to r\_inner+t2.

5 In row **3**, set **xw** to -11/3, and **yw** to r\_inner+t2.

6 In row **4**, set **yw** to r\_inner+t2.

*Work Plane 1 (wp1) > Convert to Solid 2 (csol2)*

1 In the **Work Plane** toolbar, click  **Conversions** and choose **Convert to Solid**.

2 Select the objects **cb1** and **pol1** only.

3 In the **Work Plane** toolbar, click  **Build All**.

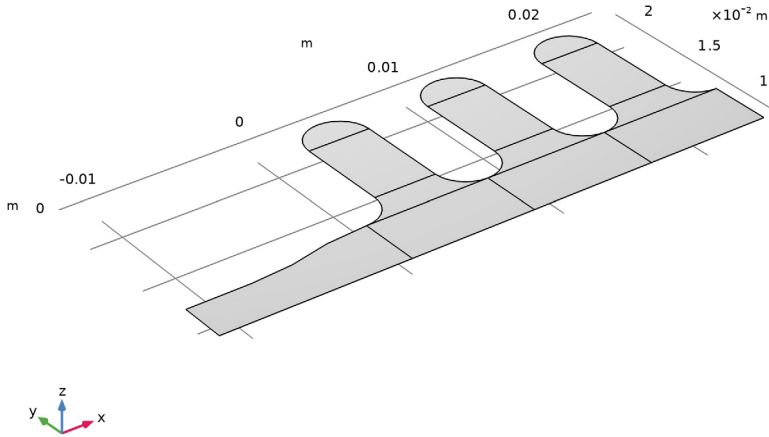

4 Click the  **Zoom Extents** button in the **Graphics** toolbar.

- 5 In the **Model Builder** window, right-click **Geometry 1** and choose **Build All**.  
You obtain the following 2D geometry.



Next, revolve the embedded 2D geometry to create the 3D model geometry.

*Revolve 1 (rev1)*

- 1 In the **Geometry** toolbar, click  **Revolve**.
- 2 In the **Settings** window for **Revolve**, locate the **Revolution Angles** section.
- 3 Click the **Angles** button.
- 4 In the **End angle** text field, type 180.
- 5 Locate the **Revolution Axis** section. Find the **Direction of revolution axis** subsection. In the **xw** text field, type 1.
- 6 In the **yw** text field, type 0.
- 7 In the **Geometry** toolbar, click  **Build All**.

8 Click the  **Go to Default View** button in the **Graphics** toolbar.

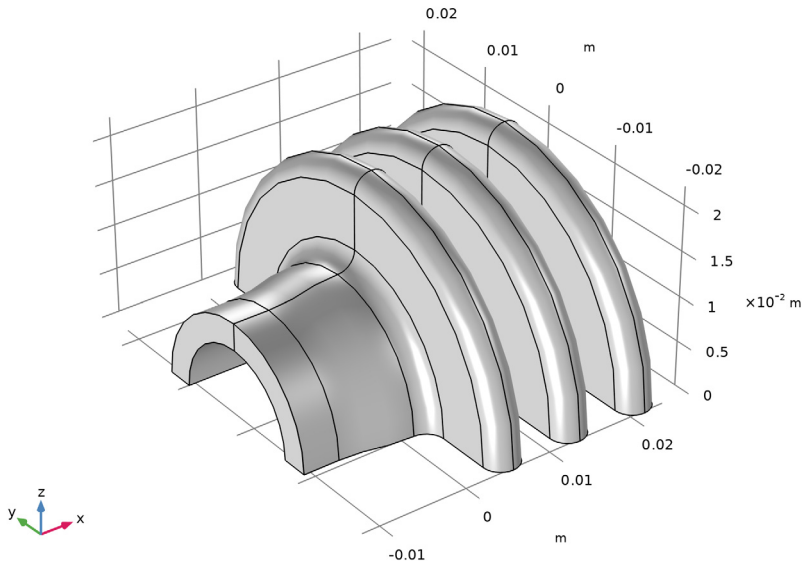

Disable the analysis of the geometry as the remaining small geometric details can be kept.

9 In the **Model Builder** window, click **Geometry I**.

10 In the **Settings** window for **Geometry**, locate the **Cleanup** section.

11 Clear the **Automatic detection of small details** checkbox.

## DEFINITIONS

### *Variables I*

1 In the **Definitions** toolbar, click  **Local Variables**.

2 In the **Settings** window for **Variables**, locate the **Geometric Entity Selection** section.

3 From the **Geometric entity level** list, choose **Boundary**.

- 4 Select Boundaries 3, 7, 9, 10, 13, 19, 23, 25, 29, 32, 35, 38–42, 45, 51, 55, 57, 61, 64, 67, 70–74, 77, 83, 87, 89, 93, 96, 99, and 102–106 only.

To do this, first copy the list of boundaries from this text, then use the **Paste Selection** button in the **Geometric Entity Selection** section, to paste these numbers.

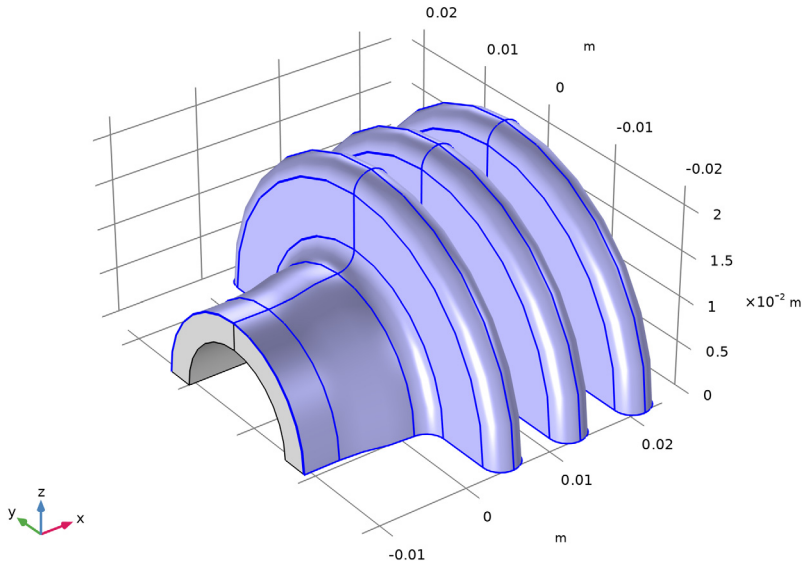



For use when specifying the boundary condition for the flange’s outer surface, create a selection.

- 5 Click  **Create Selection**.
- 6 In the **Create Selection** dialog, type Outer Boundaries in the **Selection name** text field.
- 7 Click **OK**.
- 8 In the **Settings** window for **Variables**, locate the **Variables** section.
- 9 In the table, enter the following settings:

Name	Expression	Unit	Description
alphap	$1/\text{ampr}1.T\_amb$		Coefficient of thermal expansion
Gr	$g\_const*\text{alphap}*(T-\text{ampr}1.T\_amb)*D^3/\nu^2$		Grashof number

Name	Expression	Unit	Description
theta	atan(y/z)+90[deg]	rad	Incidence angle
Hc	k*f(theta)*Gr <sup>0.25</sup> /D		Heat transfer film coefficient

### ADD MATERIAL

- 1 In the **Materials** toolbar, click  **Add Material** to open the **Add Material** window.
- 2 Go to the **Add Material** window.
- 3 In the tree, select **Built-in** > **Silica glass**.
- 4 Click the **Add to Component** button in the window toolbar.
- 5 In the **Materials** toolbar, click  **Add Material** to close the **Add Material** window.

### DEFINITIONS

#### *Ambient Properties 1 (ampr1)*

- 1 In the **Physics** toolbar, click  **Shared Properties** and choose **Ambient Properties**.
- 2 In the **Settings** window for **Ambient Properties**, locate the **Ambient Conditions** section.
- 3 In the  $T_{amb}$  text field, type 298[K].

### HEAT TRANSFER IN SOLIDS (HT)

The next steps set the temperature shape function to **Quadratic serendipity** in order to reduce computational costs without significant deterioration in accuracy.

- 1 In the **Model Builder** window, under **Component 1 (comp1)** click **Heat Transfer in Solids (ht)**.
- 2 In the **Settings** window for **Heat Transfer in Solids**, click to expand the **Discretization** section.
- 3 From the **Temperature** list, choose **Quadratic serendipity**.

#### *Initial Values 1*

- 1 In the **Model Builder** window, under **Component 1 (comp1)** > **Heat Transfer in Solids (ht)** click **Initial Values 1**.
- 2 In the **Settings** window for **Initial Values**, locate the **Initial Values** section.
- 3 In the  $T$  text field, type 323.15[K].

#### *Symmetry 1*

- 1 In the **Physics** toolbar, click  **Boundaries** and choose **Symmetry**.
- 2 Click the  **Wireframe Rendering** button in the **Graphics** toolbar.

- 3 Select Boundaries 2, 8, 12, 15, 21, 22, 24, 27, 33, 34, 44, 47, 53, 54, 56, 59, 65, 66, 76, 79, 85, 86, 88, 91, 97, and 98 only.

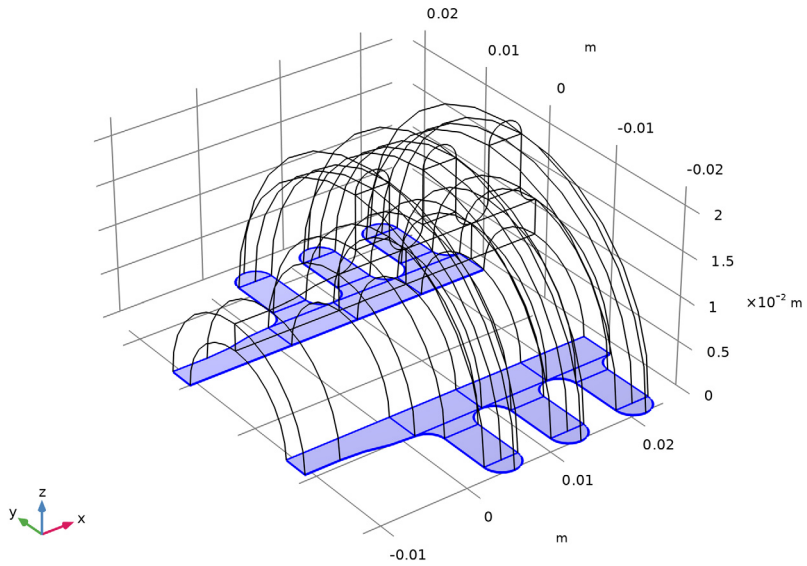

*Heat Flux I*

- 1 In the **Physics** toolbar, click  **Boundaries** and choose **Heat Flux**.

2 Select Boundaries 4, 6, 16, 18, 48, 50, 80, and 82 only.

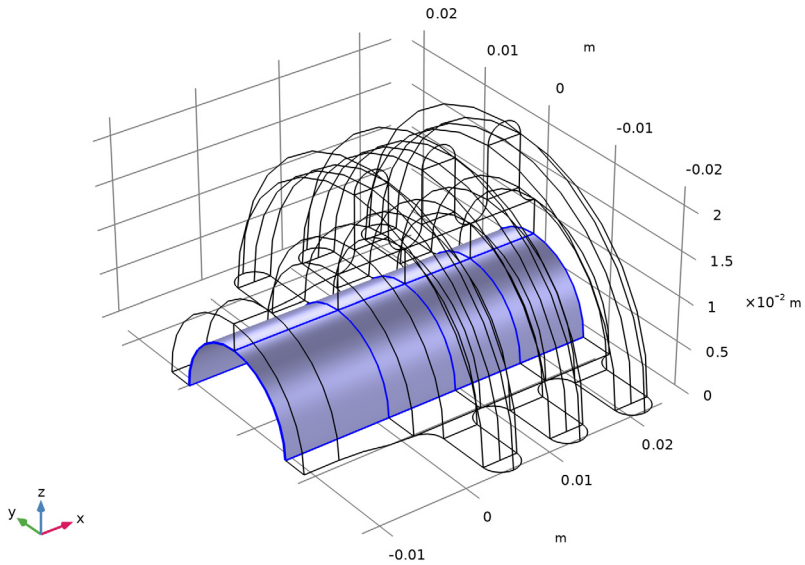

3 In the **Settings** window for **Heat Flux**, locate the **Heat Flux** section.

4 From the **Flux type** list, choose **Convective heat flux**.

5 In the  $h$  text field, type Hh.

6 In the  $T_{\text{ext}}$  text field, type  $T_{\text{inner}}$ .

7 Click the  **Wireframe Rendering** button in the **Graphics** toolbar to go back to the original view.

#### *Heat Flux 2*

1 In the **Physics** toolbar, click  **Boundaries** and choose **Heat Flux**.

2 In the **Settings** window for **Heat Flux**, locate the **Boundary Selection** section.

3 From the **Selection** list, choose **Outer Boundaries**.



4 Locate the **Heat Flux** section. From the **Flux type** list, choose **Convective heat flux**.

5 In the  $h$  text field, type Hc.

6 From the  $T_{\text{ext}}$  list, choose **Ambient temperature (ampr1)**.

## MESH 1

### *Mapped 1*

- 1 In the **Mesh** toolbar, click  **More Generators** and choose **Mapped**.
- 2 Click the  **Go to XY View** button in the **Graphics** toolbar. Do this twice to see the boundary mesh.
- 3 Select Boundaries 8, 21, 22, 33, 53, 54, 65, 85, 86, and 97 only.

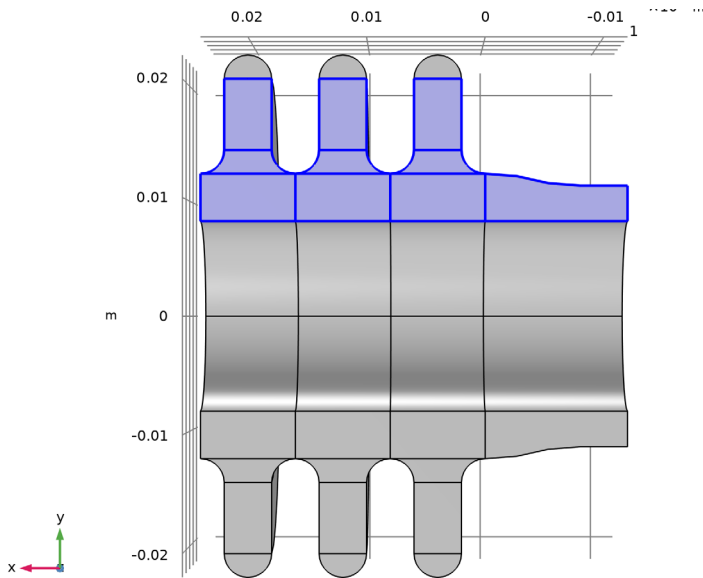

### *Size 1*

- 1 In the **Mesh** toolbar, click **Size Attribute** and choose **Extra Fine**.
- 2 In the **Settings** window for **Size**, click  **Build Selected**.

### *Free Triangular 1*

- 1 In the **Mesh** toolbar, click  **More Generators** and choose **Free Triangular**.
- 2 Select Boundaries 34, 66, and 98 only.

3 In the **Settings** window for **Free Triangular**, click  **Build Selected**.

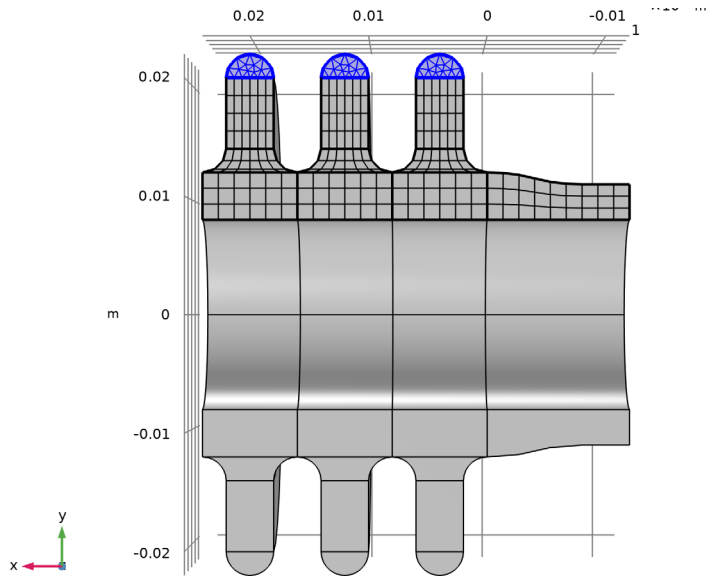

4 Click the  **Go to Default View** button in the **Graphics** toolbar.

*Swept 1*

In the **Mesh** toolbar, click  **Swept**.

*Distribution 1*

1 Right-click **Swept 1** and choose **Distribution**.

2 In the **Settings** window for **Distribution**, locate the **Distribution** section.

3 In the **Number of elements** text field, type 30.

4 Click  **Build All**.

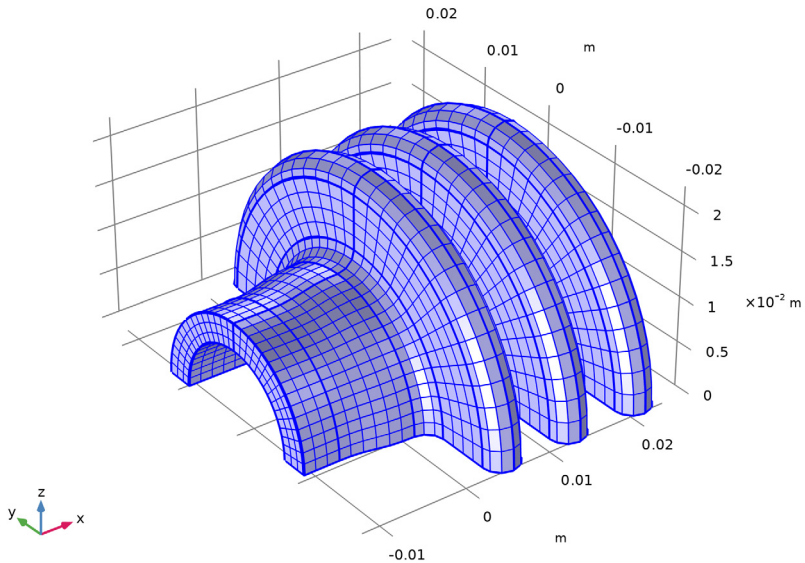



### STUDY 1

In the **Study** toolbar, click  **Compute**.

### RESULTS

#### *Temperature (ht)*

The default plot group shows the volume temperature field. To get a more intuitive view with gravity along the vertical, rotate the geometry in the **Graphics** window. You can preserve a view for a plot by creating a **View** node as follows:

- 1 In the **Settings** window for **3D Plot Group**, locate the **Plot Settings** section.
- 2 From the **View** list, choose **New view**.
- 3 In the **Temperature (ht)** toolbar, click  **Plot**.
- 4 Click  **Go to Source**.

#### *View 3D 3*

- 1 In the **Model Builder** window, under **Results > Views** click **View 3D 3**.
- 2 In the **Settings** window for **View 3D**, locate the **View** section.

- 3 Select the **Lock camera** checkbox.



Compare with [Figure 4](#).

Follow the next steps to create a new surface plot of the heat transfer film coefficient.



#### *Heat Transfer Film Coefficient*

- 1 In the **Results** toolbar, click  **3D Plot Group**.
- 2 In the **Settings** window for **3D Plot Group**, type Heat Transfer Film Coefficient in the **Label** text field.
- 3 Locate the **Plot Settings** section. From the **View** list, choose **View 3D 3**.

#### *Surface 1*

- 1 In the **Heat Transfer Film Coefficient** toolbar, click  **Surface**.
- 2 In the **Settings** window for **Surface**, click **Replace Expression** in the upper-right corner of the **Expression** section. From the menu, choose **Component 1 (comp1) > Definitions > Variables > Hc - Heat transfer film coefficient - W/(m²·K)**.
- 3 In the **Heat Transfer Film Coefficient** toolbar, click  **Plot**.  
Compare this plot with that in [Figure 5](#).

#### *Outgoing Heat Flux*

- 1 In the **Results** toolbar, click  **More Derived Values** and choose **Integration > Surface Integration**.
- 2 In the **Settings** window for **Surface Integration**, type Outgoing Heat Flux in the **Label** text field.
- 3 Locate the **Selection** section. From the **Selection** list, choose **Outer Boundaries**.
- 4 Click **Replace Expression** in the upper-right corner of the **Expressions** section. From the menu, choose **Component 1 (comp1) > Heat Transfer in Solids > Boundary fluxes > ht.ntflux - Normal total heat flux - W/m²**.
- 5 Click  **Evaluate**.

#### **TABLE 1**

- 1 Go to the **Table 1** window.

The integrated value, approximately 0.51 W, appears in the **Table** tab below the **Graphics** window. Taking both flange halves into account, the total cooling power of the flange is thus roughly 1 W.

Finally, extend the model by performing a parametric sweep over the inner pipe radius. Before adding a separate study for this purpose, define a variable for the total cooling power.

## DEFINITIONS

### *Integration, Outer*



- 1 In the **Definitions** toolbar, click  **Nonlocal Couplings** and choose **Integration**.
- 2 In the **Settings** window for **Integration**, type **Integration**, **Outer** in the **Label** text field.
- 3 In the **Operator name** text field, type `intop_outer`.
- 4 Locate the **Source Selection** section. From the **Geometric entity level** list, choose **Boundary**.
- 5 From the **Selection** list, choose **Outer Boundaries**.

### *Variables 2*

- 1 In the **Definitions** toolbar, click  **Local Variables**.
- 2 In the **Settings** window for **Variables**, locate the **Variables** section.
- 3 In the table, enter the following settings:



Name	Expression	Unit	Description
P_cooling	2*intop_outer(ht.q0)	W	Cooling power

## ADD STUDY

- 1 In the **Home** toolbar, click  **Add Study** to open the **Add Study** window.
- 2 Go to the **Add Study** window.
- 3 Find the **Studies** subsection. In the **Select Study** tree, select **General Studies** > **Stationary**.
- 4 Click the **Add Study** button in the window toolbar.
- 5 In the **Home** toolbar, click  **Add Study** to close the **Add Study** window.

## STUDY 2

### *Parametric Sweep*

- 1 In the **Study** toolbar, click  **Parametric Sweep**.
- 2 In the **Settings** window for **Parametric Sweep**, locate the **Study Settings** section.
- 3 Click  **Add**.

4 In the table, enter the following settings:

Parameter name	Parameter value list	Parameter unit
r_inner (Inner pipe radius)	range (6, 1, 10)	mm

This gives a sweep centered around the original radius value.

5 In the **Study** toolbar, click  **Compute**.

## RESULTS

*Temperature (ht) 1*

You get a new surface plot of the temperature for the parametric solution. From the **Parameter value list**, you can choose the radius value for which to display the result.

1 In the **Settings** window for **3D Plot Group**, locate the **Plot Settings** section.

2 From the **View** list, choose **View 3D 3**.

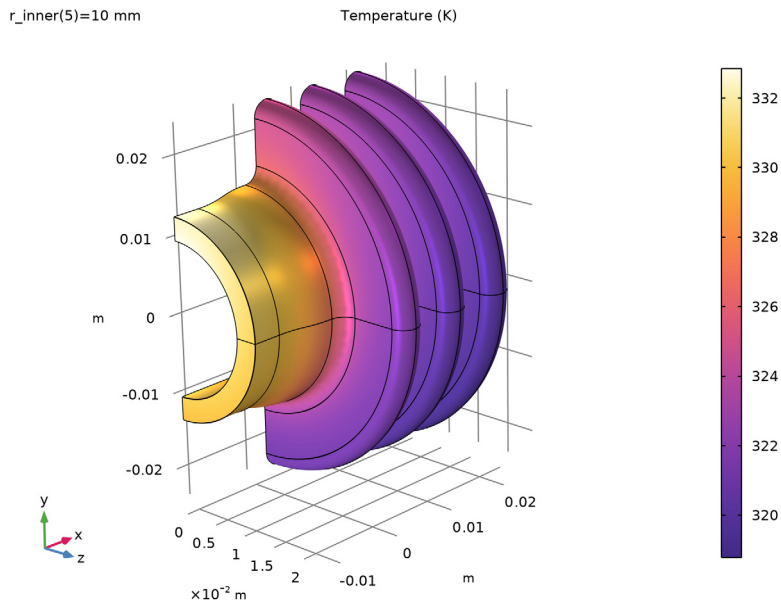

*Surface temperature for an inner radius of 10 mm.*

Finally, create a plot showing the dependence of the total cooling power versus tube radius.

### Cooling Power

- 1 In the **Results** toolbar, click  **ID Plot Group**.
- 2 In the **Settings** window for **ID Plot Group**, type `Cooling Power` in the **Label** text field.
- 3 Locate the **Data** section. From the **Dataset** list, choose **Study 2/ Parametric Solutions 1 (sol3)**.

### Global 1

- 1 In the **Cooling Power** toolbar, click  **Global**.
- 2 In the **Settings** window for **Global**, click **Add Expression** in the upper-right corner of the **y-Axis Data** section. From the menu, choose **Component 1 (comp1) > Definitions > Variables > P\_cooling - Cooling power - W**.
- 3 Click to expand the **Legends** section. Clear the **Show legends** checkbox.

### Cooling Power

- 1 In the **Model Builder** window, click **Cooling Power**.
- 2 In the **Settings** window for **ID Plot Group**, locate the **Plot Settings** section.
- 3 Select the **x-axis label** checkbox. In the associated text field, type `Inner pipe radius (m)`.
- 4 In the **Cooling Power** toolbar, click  **Plot**.  
Compare the result with the graph in [Figure 6](#).