



Model created in COMSOL Multiphysics 6.4

# Composite Thermal Barrier

## Introduction

---

This example shows how to set up multiple sandwiched thin layers with different thermal conductivities in two different ways.

First, the composite is modeled as a 3D object. In the second approach, the Thin Layer boundary condition is used to avoid resolving the thin domains, and two modeling options of this feature are compared.

The methodology is useful when modeling heat transfer through thermal barriers like multilayer coatings.

See [Lumped Composite Thermal Barrier](#) for a comparison of the 3D approach with a 0D approach using the **Thermal Connection** feature and the Lumped Thermal System interface.

## Model Definition

---

This tutorial uses a simple geometry as shown in [Figure 1](#). The cylinder has a radius of 2 cm and a height of 4 cm.

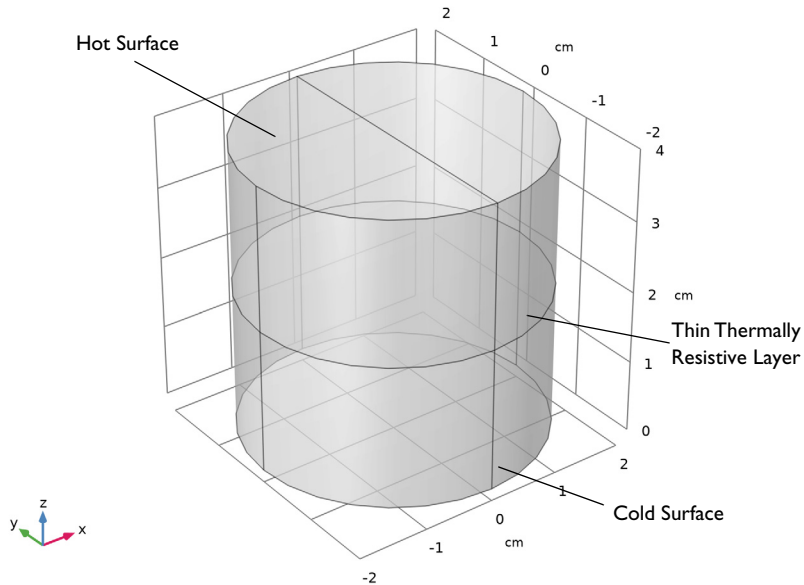

Figure 1: Geometry.

The composite consists of two layers with different thermal conductivities. The first approach resolves each layer as a 3D domain. The height of the layers is about three orders of magnitude smaller than the bulk height. This often requires to build a mesh manually to accurately resolve the thin structure.

COMSOL Multiphysics provides a special boundary condition which is available from the Heat Transfer Module, namely the Thin Layer feature.

The second approach first uses this feature with resistive property (Thermally thick approximation option). This simplifies the geometry and thus the mesh by representing the thermal barrier as a boundary. In complex geometries, this boundary condition can reduce the amount of memory and time required for the simulation significantly.

The underlying equation assumes the heat flux through the layer proportional to the temperature difference between upper and lower bulk. It is based on the assumption that the bulk on each side is well stirred so that all resistance against heat transfer is within a thin layer near the wall. Due to the additivity of resistance the flux over the composite can be lumped to

$$\begin{aligned} -\mathbf{n}_d(-k_d \nabla T_d) &= \frac{k_{\text{tot}}}{d_{\text{tot}}}(T_u - T_d) \\ -\mathbf{n}_u(-k_u \nabla T_u) &= \frac{k_{\text{tot}}}{d_{\text{tot}}}(T_d - T_u) \end{aligned}$$

where the overall thermal conductivity  $k_{\text{tot}}$  can be calculated as

$$k_{\text{tot}} = \frac{\sum_n d_n}{\sum_n \frac{d_n}{k_n}}$$

Then, the second approach uses the General option of the Thin Layer feature. In this case, an extra-dimension is defined on the boundary to resolve the heat flux both in tangential and normal direction in the layers.

## MATERIAL PROPERTIES

The cylinder is made of steel. The composite consists of two layers of different ceramics.

TABLE I: CERAMICS MATERIAL PROPERTIES.

PROPERTY	CERAMIC 1	CERAMIC 2
Thermal conductivity	1 W/(m·K)	0.5 W/(m·K)
Density	6000 kg/m <sup>3</sup>	5800 kg/m <sup>3</sup>
Heat capacity at constant pressure	320 J/(kg·K)	280 J/(kg·K)

## BOUNDARY CONDITIONS

The temperature at the bottom is fixed to 20°C whereas one half of the top boundary is held at 1220°C (1493 K). All other outer boundaries are perfectly insulated.

## Results and Discussion

Figure 2 shows the temperature distribution in the cylinder. The composite acts as a thermal barrier resulting in a jump of the temperature over the layer.

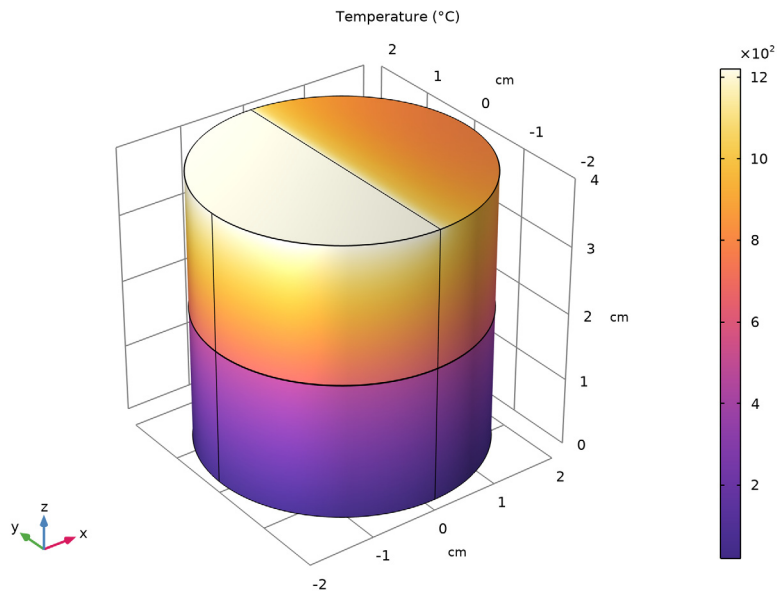
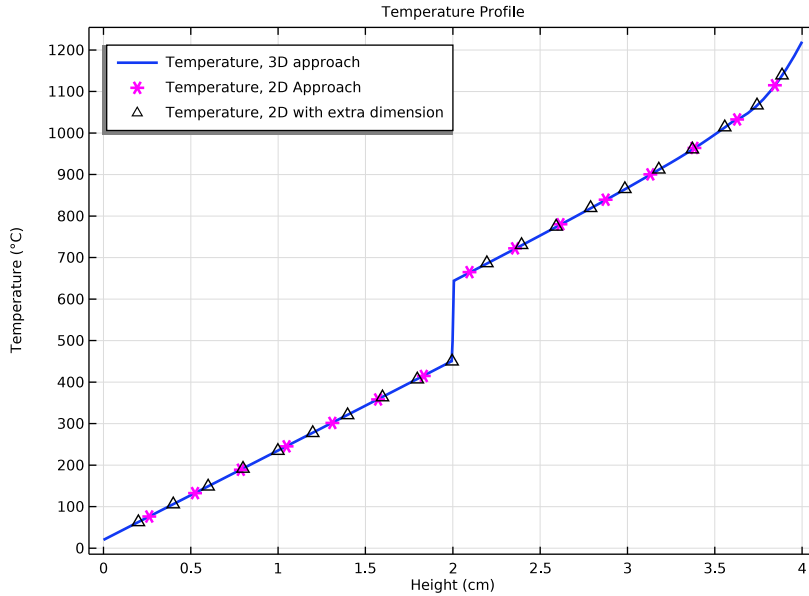

Figure 2: Temperature distribution.

Of interest is if the thin layer boundary condition produces reliable results compared to resolving the thin layers in 3D. This can be done with a comparative line graph as in [Figure 3](#). It shows that the 2D approach, with or without a 1D extra dimension, produces accurate results for the bulk temperatures.



*Figure 3: Temperature profile for 3D, 2D, and 2D with extra dimension approaches.*

Another important question for simulating is the influence on the mesh size and on the required RAM.

With the default tetrahedral mesh the number of mesh elements is about 130,000 elements and the meshing algorithm gives some warnings.

With the swept mesh feature you can significantly reduce the number of elements to about 2800 elements which is only 2% of the initial number of elements. In complex geometries the swept mesh algorithm is often not applicable. Using the thin layer boundary condition, the number of mesh elements reduces from 2800 to 2000 which is about 30% less, even in this simple geometry. You can see the number of mesh elements used in the **Messages** window below the **Graphics** window.

## Notes About the COMSOL Implementation

---

To compare the results directly, both approaches are handled in a single MPH file.

---

**Application Library path:** Heat\_Transfer\_Module/Tutorials,\_Thin\_Structure/composite\_thermal\_barrier

---

### Modeling Instructions



---

From the **File** menu, choose **New**.

#### NEW

In the **New** window, click  **Model Wizard**.

#### MODEL WIZARD

- 1 In the **Model Wizard** window, click  **3D**.
- 2 In the **Select Physics** tree, select **Heat Transfer > Heat Transfer in Solids (ht)**.
- 3 Click **Add**.
- 4 Click  **Study**.
- 5 In the **Select Study** tree, select **General Studies > Stationary**.
- 6 Click  **Done**.

#### GLOBAL DEFINITIONS

##### Parameters 1

- 1 In the **Model Builder** window, under **Global Definitions** click **Parameters 1**.
- 2 In the **Settings** window for **Parameters**, locate the **Parameters** section.
- 3 In the table, enter the following settings:



Name	Expression	Value	Description
d_ceram1	50[um]	5E-5 m	Thickness of layer 1
d_ceram2	75[um]	7.5E-5 m	Thickness of layer 2
T_hot	1220[degC]	1493.2 K	Hot temperature

#### GEOMETRY 1

- 1 In the **Model Builder** window, under **Component 1 (comp1)** click **Geometry 1**.



- 2 In the **Settings** window for **Geometry**, locate the **Units** section.
- 3 From the **Length unit** list, choose **cm**.

#### *Cylinder 1 (cyl1)*



- 1 In the **Geometry** toolbar, click  **Cylinder**.
- 2 In the **Settings** window for **Cylinder**, locate the **Size and Shape** section.
- 3 In the **Radius** text field, type 2.
- 4 In the **Height** text field, type 4.
- 5 In the **Geometry** toolbar, click  **Build All**.

Now, create thin cylinders to define the ceramic layers between the two steel domains.

#### *Cylinder 2 (cyl2)*

- 1 In the **Geometry** toolbar, click  **Cylinder**.
- 2 In the **Settings** window for **Cylinder**, locate the **Size and Shape** section.
- 3 In the **Radius** text field, type 2.
- 4 In the **Height** text field, type  $d_{\text{ceram1}}$ .
- 5 Locate the **Position** section. In the **z** text field, type  $2 - (d_{\text{ceram1}} + d_{\text{ceram2}}) / 2$ .
- 6 In the **Geometry** toolbar, click  **Build All**.

#### *Cylinder 3 (cyl3)*

- 1 In the **Geometry** toolbar, click  **Cylinder**.
- 2 In the **Settings** window for **Cylinder**, locate the **Size and Shape** section.
- 3 In the **Radius** text field, type 2.
- 4 In the **Height** text field, type  $d_{\text{ceram2}}$ .
- 5 Locate the **Position** section. In the **z** text field, type  $2 - (d_{\text{ceram1}} + d_{\text{ceram2}}) / 2 + d_{\text{ceram1}}$ .
- 6 In the **Geometry** toolbar, click  **Build All**.

#### *Line Segment 1 (ls1)*

- 1 In the **Geometry** toolbar, click  **More Primitives** and choose **Line Segment**.
- 2 In the **Settings** window for **Line Segment**, locate the **Starting Point** section.
- 3 From the **Specify** list, choose **Coordinates**.
- 4 In the **y** text field, type -2.
- 5 In the **z** text field, type 4.
- 6 Locate the **Endpoint** section. From the **Specify** list, choose **Coordinates**.

- 7 In the **y** text field, type 2.
- 8 In the **z** text field, type 4.
- 9 Click  **Build All Objects**.

## DEFINITIONS

Create operators and variables to evaluate the average temperature in the thermal barrier and in each of its layers.

### *Integration : Barrier*

- 1 In the **Model Builder** window, expand the **Component 1 (comp1) > Definitions** node.
- 2 Right-click **Definitions** and choose **Nonlocal Couplings > Integration**.
- 3 In the **Settings** window for **Integration**, locate the **Source Selection** section.
- 4 Click  **Paste Selection**.
- 5 In the **Paste Selection** dialog, type 2-3 in the **Selection** text field.
- 6 Click **OK**.
- 7 In the **Settings** window for **Integration**, type `intopBarrier` in the **Operator name** text field.
- 8 In the **Label** text field, type `Integration : Barrier`.

### *Integration : Layer 1*

- 1 Right-click **Integration : Barrier** and choose **Duplicate**.
- 2 In the **Settings** window for **Integration**, locate the **Source Selection** section.
- 3 In the list box, select **3**.
- 4 Click  **Remove from Selection**.
- 5 Select Domain 2 only.
- 6 In the **Label** text field, type `Integration : Layer 1`.
- 7 In the **Operator name** text field, type `intopLayer1`.

### *Integration : Layer 2*

- 1 In the **Model Builder** window, under **Component 1 (comp1) > Definitions** right-click **Integration : Barrier (intopBarrier)** and choose **Duplicate**.
- 2 In the **Settings** window for **Integration**, locate the **Source Selection** section.
- 3 In the list box, select **2**.
- 4 Click  **Remove from Selection**.
- 5 Select Domain 3 only.

6 In the **Label** text field, type Integration : Layer 2.

7 In the **Operator name** text field, type intopLayer2.

*Variables: temperature in thermal barrier*

1 In the **Model Builder** window, right-click **Definitions** and choose **Variables**.

2 In the **Settings** window for **Variables**, locate the **Variables** section.

3 In the table, enter the following settings:

<b>Name</b>	<b>Expression</b>	<b>Unit</b>	<b>Description</b>
vol_barrier	intopBarrier(1)	m <sup>3</sup>	Volume of barrier
vol_layer1	intopLayer1(1)	m <sup>3</sup>	Volume of layer 1
vol_layer2	intopLayer2(1)	m <sup>3</sup>	Volume of layer 2
T_int_barrier	intopBarrier(T)	m <sup>3</sup> ·K	Integral of temperature in thermal barrier
T_int_layer1	intopLayer1(T)	m <sup>3</sup> ·K	Integral of temperature in layer 1
T_int_layer2	intopLayer2(T)	m <sup>3</sup> ·K	Integral of temperature in layer 2
T_ave_barrier	intopBarrier(T)/ intopBarrier(1)	K	Average of temperature in thermal barrier
T_ave_layer1	intopLayer1(T)/ intopLayer1(1)	K	Average of temperature in layer 1
T_ave_layer2	intopLayer2(T)/ intopLayer2(1)	K	Average of temperature in layer 2

4 In the **Label** text field, type Variables: temperature in thermal barrier.

## **MATERIALS**

*Material Link 1 (matlnk1)*

1 In the **Model Builder** window, under **Component 1 (comp1)** right-click **Materials** and choose **More Materials > Material Link**.



- 2 In the **Settings** window for **Material Link**, locate the **Link Settings** section.
- 3 Click  **Add Material from Library**.

#### ADD MATERIAL TO MATERIAL LINK 1 (MATLNK1)

- 1 Go to the **Add Material to Material Link 1 (matlnk1)** window.
- 2 In the tree, select **Built-in > Steel AISI 4340**.
- 3 Right-click and choose **Add Material**.

#### MATERIALS

##### *Material Link 2 (matlnk2)*

- 1 Right-click **Materials** and choose **More Materials > Material Link**.
- 2 In the **Settings** window for **Material Link**, locate the **Geometric Entity Selection** section.
- 3 Click  **Paste Selection**.
- 4 In the **Paste Selection** dialog, type 2 in the **Selection** text field.
- 5 Click **OK**.
- 6 In the **Settings** window for **Material Link**, locate the **Link Settings** section.
- 7 Click  **Blank Material**.
- 8 In the **Model Builder** window, click **Material Link 2 (matlnk2)**.
- 9 Click  **Go to Material**.

#### GLOBAL DEFINITIONS



##### *Ceramic 1*

- 1 In the **Model Builder** window, under **Global Definitions > Materials** click **Material 2 (mat2)**.
- 2 In the **Settings** window for **Material**, type Ceramic 1 in the **Label** text field.
- 3 Locate the **Material Contents** section. In the table, enter the following settings:

Property	Variable	Value	Unit	Property group
Thermal conductivity	$k_{iso}$ ; $k_{ii} = k_{iso}$ , $k_{ij} = 0$	1 [W/(m*K)]	W/(m·K)	Basic
Density	$\rho$	6000 [kg/m <sup>3</sup> ]	kg/m <sup>3</sup>	Basic
Heat capacity at constant pressure	$C_p$	320 [J/(kg*K)]	J/(kg·K)	Basic

## MATERIALS

### Material Link 3 (matlnk3)

- 1 In the **Model Builder** window, under **Component 1 (comp1)** right-click **Materials** and choose **More Materials > Material Link**.
- 2 In the **Settings** window for **Material Link**, locate the **Geometric Entity Selection** section.
- 3 Click  **Paste Selection**.
- 4 In the **Paste Selection** dialog, type 3 in the **Selection** text field.
- 5 Click **OK**.
- 6 In the **Settings** window for **Material Link**, locate the **Link Settings** section.
- 7 Click  **Blank Material**.
- 8 In the **Model Builder** window, click **Material Link 3 (matlnk3)**.
- 9 Click  **Go to Material**.

## GLOBAL DEFINITIONS

### Ceramic 2

- 1 In the **Model Builder** window, under **Global Definitions > Materials** click **Material 3 (mat3)**.
- 2 In the **Settings** window for **Material**, type Ceramic 2 in the **Label** text field.
- 3 Locate the **Material Contents** section. In the table, enter the following settings:

Property	Variable	Value	Unit	Property group
Thermal conductivity	$k_{iso}$ ; $k_{ii} = k_{iso}$ , $k_{ij} = 0$	0.5 [W/ (m* K) ]	W/(m·K)	Basic
Density	$\rho$	5800 [kg/ m <sup>3</sup> ]	kg/m <sup>3</sup>	Basic
Heat capacity at constant pressure	$C_p$	280 [J/ (kg*K) ]	J/(kg·K)	Basic

## HEAT TRANSFER IN SOLIDS (HT)

### Temperature 1

- 1 In the **Physics** toolbar, click  **Boundaries** and choose **Temperature**.
- 2 Select Boundary 3 only.

### Temperature 2



- 1 In the **Physics** toolbar, click  **Boundaries** and choose **Temperature**.

- 2 Select Boundary 13 only.
- 3 In the **Settings** window for **Temperature**, locate the **Temperature** section.
- 4 In the  $T_0$  text field, type  $T_{hot}$ .

### MESH I

First, mesh the top surface with a free triangular mesh and extrude it in layers through the cylindrical geometry. With a **Distribution** node, specify how many mesh layers are to be created within the domain. Resolve the composite layers with two elements in thickness.

#### *Free Triangular I*

- 1 In the **Mesh** toolbar, click  **More Generators** and choose **Free Triangular**.
- 2 Select Boundaries 13 and 18 only.
- 3 In the **Settings** window for **Free Triangular**, click  **Build Selected**.

#### *Swept I*

In the **Mesh** toolbar, click  **Swept**.

#### *Distribution I*

- 1 Right-click **Swept I** and choose **Distribution**.
- 2 Select Domains 2 and 3 only.
- 3 In the **Settings** window for **Distribution**, locate the **Distribution** section.
- 4 In the **Number of elements** text field, type 2.
- 5 Click  **Build All**.



### STUDY I

In the **Study** toolbar, click  **Compute**.

### RESULTS

Change the unit of the temperature results to degrees Celsius.

#### *Preferred Units I*

- 1 In the **Results** toolbar, click  **Configurations** and choose **Preferred Units**.
- 2 In the **Settings** window for **Preferred Units**, locate the **Units** section.
- 3 Click  **Add Physical Quantity**.
- 4 In the **Physical Quantity** dialog, select **General > Temperature (K)** in the tree.
- 5 Click **OK**.
- 6 In the **Settings** window for **Preferred Units**, locate the **Units** section.

7 In the table, enter the following settings:

Quantity	Unit	Preferred unit
Temperature	K	°C

8 Click  **Apply**.

#### *Temperature, 3D Approach*

The following plot is produced by default: temperature profile in the volume as in [Figure 2](#).

- 1 In the **Model Builder** window, under **Results** click **Temperature (ht)**.
- 2 In the **Settings** window for **3D Plot Group**, type Temperature, 3D Approach in the **Label** text field.

#### *Volume 1*

- 1 In the **Model Builder** window, expand the **Temperature, 3D Approach** node, then click **Volume 1**.
- 2 In the **Temperature, 3D Approach** toolbar, click  **Plot**.

Next, create a temperature profile along the height of the cylinder. You will later compare the graph with the results of the 2D approach.

#### *Temperature Profile*

- 1 In the **Results** toolbar, click  **ID Plot Group**.
- 2 In the **Settings** window for **ID Plot Group**, type Temperature Profile in the **Label** text field.
- 3 Locate the **Plot Settings** section.
- 4 Select the **x-axis label** checkbox. In the associated text field, type Height (cm).
- 5 Click to expand the **Title** section. From the **Title type** list, choose **Manual**.
- 6 In the **Title** text area, type Temperature Profile.
- 7 Locate the **Legend** section. From the **Position** list, choose **Upper left**.

#### *Line Graph 1*

- 1 In the **Temperature Profile** toolbar, click  **Line Graph**.
- 2 Select Edges 15, 17, 19, and 21 only.
- 3 In the **Settings** window for **Line Graph**, locate the **x-Axis Data** section.
- 4 From the **Parameter** list, choose **Expression**.
- 5 In the **Expression** text field, type z.

- 6 Click to expand the **Coloring and Style** section. From the **Width** list, choose **2**.
- 7 Click to expand the **Legends** section. Select the **Show legends** checkbox.
- 8 From the **Legends** list, choose **Manual**.
- 9 In the table, enter the following settings:

---

#### **Legends**

---

Temperature, 3D approach

---

- 10 In the **Temperature Profile** toolbar, click  **Plot**.

Now let all the plots being regenerated after solving.



- 11 In the **Model Builder** window, click **Results**.
- 12 In the **Settings** window for **Results**, locate the **Update of Results** section.
- 13 Select the **Recompute all plot data after solving** checkbox.

Create now the second model which uses the **Thin Layer** feature and compare the results to the first approach.

#### **ADD COMPONENT**

In the **Model Builder** window, right-click the root node and choose **Add Component > 3D**.

#### **ADD PHYSICS**

- 1 In the **Home** toolbar, click  **Add Physics** to open the **Add Physics** window.
- 2 Go to the **Add Physics** window.
- 3 In the tree, select **Heat Transfer > Heat Transfer in Solids (ht)**.
- 4 Find the **Physics interfaces in study** subsection. In the table, clear the **Solve** checkbox for **Study 1**.
- 5 Click the **Add to Component 2** button in the window toolbar.
- 6 In the **Home** toolbar, click  **Add Physics** to close the **Add Physics** window.

#### **ADD STUDY**

- 1 In the **Home** toolbar, click  **Add Study** to open the **Add Study** window.
- 2 Go to the **Add Study** window.
- 3 Find the **Studies** subsection. In the **Select Study** tree, select **General Studies > Stationary**.
- 4 Find the **Physics interfaces in study** subsection. In the table, clear the **Solve** checkbox for **Heat Transfer in Solids (ht)**.
- 5 Click the **Add Study** button in the window toolbar.

6 In the **Home** toolbar, click  **Add Study** to close the **Add Study** window.

## GEOMETRY 2

1 In the **Settings** window for **Geometry**, locate the **Units** section.

2 From the **Length unit** list, choose **cm**.

### *Cylinder 1 (cyl1)*

1 In the **Geometry** toolbar, click  **Cylinder**.

2 In the **Settings** window for **Cylinder**, locate the **Size and Shape** section.

3 In the **Radius** text field, type 2.

4 In the **Height** text field, type 4.

5 Click to expand the **Layers** section. In the table, enter the following settings:

Layer name	Thickness (cm)
Layer 1	2

6 Clear the **Layers on side** checkbox.

7 Select the **Layers on bottom** checkbox.

8 In the **Geometry** toolbar, click  **Build All**.

### *Line Segment 1 (ls1)*

1 In the **Geometry** toolbar, click  **More Primitives** and choose **Line Segment**.

2 In the **Settings** window for **Line Segment**, locate the **Starting Point** section.

3 From the **Specify** list, choose **Coordinates**.

4 In the **y** text field, type -2.

5 In the **z** text field, type 4.

6 Locate the **Endpoint** section. From the **Specify** list, choose **Coordinates**.

7 In the **y** text field, type 2.

8 In the **z** text field, type 4.

9 In the **Geometry** toolbar, click  **Build All**.

## DEFINITIONS (COMP2)

In order to make the comparison with **Component 1**, create an **Integration** operator and variables to evaluate the average temperature in the thermal barrier and in each of its layers.

### *Integration : Boundary*

1 In the **Model Builder** window, expand the **Component 2 (comp2) > Definitions** node.

- 2 Right-click **Component 2 (comp2)** > **Definitions** and choose **Nonlocal Couplings** > **Integration**.
- 3 In the **Settings** window for **Integration**, type **Integration : Boundary** in the **Label** text field.
- 4 In the **Operator name** text field, type **intopBnd**.
- 5 Locate the **Source Selection** section. From the **Geometric entity level** list, choose **Boundary**.
- 6 Click  **Paste Selection**.
- 7 In the **Paste Selection** dialog, type **6** in the **Selection** text field.
- 8 Click **OK**.

*Variables: temperature in thermal barrier*

- 1 Right-click **Definitions** and choose **Variables**.
- 2 In the **Settings** window for **Variables**, locate the **Variables** section.
- 3 In the table, enter the following settings:

Name	Expression	Unit	Description
isLayer1	llmat1_xdim.atonly(dom==1)		Layer 1 identifier (=1 in layer 1, 0 elsewhere)
isLayer2	llmat1_xdim.atonly(dom==2)		Layer 2 identifier (=1 in layer 2, 0 elsewhere)
vol_barrier	intopBnd(ht2.sls2.xdintopall(1))		Volume of thermal barrier
vol_layer1	intopBnd(ht2.sls2.xdintopall(isLayer1))		Volume of layer 1
vol_layer2	intopBnd(ht2.sls2.xdintopall(isLayer2))		Volume of layer 2
T_int_barrier	intopBnd(ht2.sls2.xdintopall(T2))		Integral of temperature in thermal barrier

Name	Expression	Unit	Description
T_int_layer1	intopBnd(ht2.sls2.xdintopall (T2*isLayer1))		Integral of temperature in layer 1
T_int_layer2	intopBnd(ht2.sls2.xdintopall (T2*isLayer2))		Integral of temperature in layer 2
T_ave_barrier	T_int_barrier/vol_barrier		Average of temperature in thermal barrier
T_ave_layer1	T_int_layer1/vol_layer1		Average of temperature in layer 1
T_ave_layer2	T_int_layer2/vol_layer2		Average of temperature in layer 2

4 In the **Label** text field, type Variables: temperature in thermal barrier.

## MATERIALS

*Material Link 4 (matlnk4)*

In the **Model Builder** window, under **Component 2 (comp2)** right-click **Materials** and choose **More Materials > Material Link**.

## GLOBAL DEFINITIONS

*Layered Material 1 (lmat1)*

1 In the **Model Builder** window, under **Global Definitions** right-click **Materials** and choose **Layered Material**.

2 In the **Settings** window for **Layered Material**, locate the **Layer Definition** section.

3 In the table, enter the following settings:

Layer	Material	Rotation	Value	Thickness	Mesh elements
Layer 1	Ceramic I (mat2)	0.0	0 rad	d_ceram1	2

4 Click **+ Add**.

5 In the table, enter the following settings:

Layer	Material	Rotation	Value	Thickness	Mesh elements
Layer 2	Ceramic 2 (mat3)	0.0	0 rad	d_ceram2	2

## MATERIALS

### *Layered Material Link 1 (lmat1)*

- 1 In the **Model Builder** window, under **Component 2 (comp2)** right-click **Materials** and choose **Layers > Layered Material Link**.
- 2 Select Boundary 6 only.

## HEAT TRANSFER IN SOLIDS 2 (HT2)

Add two **Thin Layer** nodes on the same boundary. They will be activated each in two separated studies, to compare the **Thermally thick approximation** and **General** options.

### *Thin Layer 1*

- 1 In the **Physics** toolbar, click  **Boundaries** and choose **Thin Layer**.
- 2 Select Boundary 6 only.

### *Thin Layer 2*

- 1 In the **Physics** toolbar, click  **Boundaries** and choose **Thin Layer**.
- 2 Select Boundary 6 only.
- 3 In the **Settings** window for **Thin Layer**, locate the **Layer Model** section.
- 4 From the **Layer type** list, choose **General**.

### *Temperature 1*

- 1 In the **Physics** toolbar, click  **Boundaries** and choose **Temperature**.
- 2 Select Boundary 3 only.

### *Temperature 2*

- 1 In the **Physics** toolbar, click  **Boundaries** and choose **Temperature**.
- 2 Select Boundary 7 only.
- 3 In the **Settings** window for **Temperature**, locate the **Temperature** section.
- 4 In the  $T_0$  text field, type T\_hot.



## STUDY 2

### Step 1: Stationary

- 1 In the **Model Builder** window, under **Study 2** click **Step 1: Stationary**.
- 2 In the **Settings** window for **Stationary**, locate the **Physics and Variables Selection** section.
- 3 Select the **Modify model configuration for study step** checkbox.  
Disable **Thin Layer 2** in this study. First, **Thin Layer 1** is used to show the results with the **Thermally thick approximation** option. Later, another study will use **Thin Layer 2** with the **General** option.
- 4 In the tree, select **Component 2 (comp2) > Heat Transfer in Solids 2 (ht2) > Thin Layer 2**.
- 5 Click  **Disable**.

## MESH 2

### Free Triangular 1

- 1 In the **Mesh** toolbar, click  **More Generators** and choose **Free Triangular**.
- 2 Select Boundaries 7 and 10 only.
- 3 In the **Settings** window for **Free Triangular**, click  **Build Selected**.

### Swept 1

- 1 In the **Mesh** toolbar, click  **Swept**.
- 2 In the **Model Builder** window, right-click **Mesh 2** and choose **Build All**.

## STUDY 2

In the **Study** toolbar, click  **Compute**.

## RESULTS

### Temperature Profile

In the **Model Builder** window, expand the **Results > Temperature (ht2)** node, then click **Results > Temperature Profile**.

### Line Graph 2

- 1 Right-click **Temperature Profile** and choose **Line Graph**.
- 2 In the **Settings** window for **Line Graph**, locate the **Data** section.
- 3 From the **Dataset** list, choose **Study 2/Solution 2 (3) (sol2)**.
- 4 Select Edges 9 and 11 only.

- 5 Click **Replace Expression** in the upper-right corner of the **y-Axis Data** section. From the menu, choose **Component 2 (comp2) > Heat Transfer in Solids 2 > Temperature > T2 - Temperature - K**.
- 6 Locate the **x-Axis Data** section. From the **Parameter** list, choose **Expression**.
- 7 In the **Expression** text field, type **z**.
- 8 Locate the **Coloring and Style** section. Find the **Line style** subsection. From the **Line** list, choose **None**.
- 9 From the **Color** list, choose **Magenta**.
- 10 Find the **Line markers** subsection. From the **Marker** list, choose **Cycle**.
- 11 From the **Positioning** list, choose **Interpolated**.
- 12 In the **Number** text field, type **15**.
- 13 Locate the **Legends** section. Select the **Show legends** checkbox.
- 14 From the **Legends** list, choose **Manual**.
- 15 In the table, enter the following settings:

Legends
Temperature, 2D Approach

- 16 In the **Temperature Profile** toolbar, click  **Plot**.

*Temperature, 2D Approach*

- 1 In the **Model Builder** window, under **Results** click **Temperature (ht2)**.
- 2 In the **Settings** window for **3D Plot Group**, type **Temperature, 2D Approach** in the **Label** text field.

Next, add a study to solve **Component 2** with **Thin Layer 2** instead of **Thin Layer 1**. The **Thin Layer 2** feature would use the **General** option which creates a 1D extra dimension formed by two intervals to represent the two ceramic layers.



#### ADD STUDY

- 1 In the **Home** toolbar, click  **Add Study** to open the **Add Study** window.
- 2 Go to the **Add Study** window.
- 3 Find the **Studies** subsection. In the **Select Study** tree, select **General Studies > Stationary**.
- 4 Find the **Physics interfaces in study** subsection. In the table, clear the **Solve** checkbox for **Heat Transfer in Solids (ht)**.
- 5 Click the **Add Study** button in the window toolbar.

6 In the **Home** toolbar, click  **Add Study** to close the **Add Study** window.

### STUDY 3

#### *Step 1: Stationary*

- 1 In the **Settings** window for **Stationary**, locate the **Physics and Variables Selection** section.
- 2 Select the **Modify model configuration for study step** checkbox.
- 3 In the tree, select **Component 2 (comp2) > Heat Transfer in Solids 2 (ht2) > Thin Layer 1**.
- 4 Click  **Disable**.
- 5 In the **Study** toolbar, click  **Compute**.

### RESULTS

#### *Temperature Profile*

In the **Model Builder** window, expand the **Results > Temperature (ht2)** node, then click **Results > Temperature Profile**.

#### *Line Graph 3*

- 1 In the **Temperature Profile** toolbar, click  **Line Graph**.
- 2 In the **Settings** window for **Line Graph**, locate the **Data** section.
- 3 From the **Dataset** list, choose **Study 3/Solution 3 (5) (sol3)**.
- 4 Select Edges 9 and 11 only.
- 5 Locate the **y-Axis Data** section. In the **Expression** text field, type T2.
- 6 Locate the **x-Axis Data** section. From the **Parameter** list, choose **Expression**.
- 7 In the **Expression** text field, type z.
- 8 Locate the **Coloring and Style** section. Find the **Line style** subsection. From the **Line** list, choose **None**.
- 9 From the **Color** list, choose **From theme**.
- 10 From the **Width** list, choose **2**.
- 11 Find the **Line markers** subsection. From the **Marker** list, choose **Triangle**.
- 12 From the **Positioning** list, choose **Interpolated**.
- 13 In the **Number** text field, type 20.
- 14 Locate the **Legends** section. Select the **Show legends** checkbox.
- 15 From the **Legends** list, choose **Manual**.

16 In the table, enter the following settings:

---

**Legends**

---

Temperature, 2D with extra dimension approach

---

17 In the **Temperature Profile** toolbar, click  **Plot**.

The plot should look like [Figure 3](#).

Create a group for current and forthcoming plots corresponding to the 2D with extra dimension approach.

*Temperature (ht2)*

In the **Model Builder** window, under **Results** right-click **Temperature (ht2)** and choose **Group**.

*2D With Extra Dimension Approach*

In the **Settings** window for **Group**, type 2D With Extra Dimension Approach in the **Label** text field.

Also, place the plot comparing the different approaches under a specific node.

*Temperature Profile*

In the **Model Builder** window, under **Results** right-click **Temperature Profile** and choose **Group**.

*Comparison of the Different Approaches*

In the **Settings** window for **Group**, type Comparison of the Different Approaches in the **Label** text field.

Next, create plots to compare more in details the results obtained with **Study 1** and **Study 3** for the temperature in the ceramic layers. In addition, evaluate the average of the thermal barrier temperature obtained with these two studies.

First, create a plot for the temperature solution at the surface of the thermal barrier.

*Temperature (Layers Surface)*

1 In the **Results** toolbar, click  **3D Plot Group**.

2 In the **Settings** window for **3D Plot Group**, type Temperature (Layers Surface) in the **Label** text field.

3 Locate the **Data** section. From the **Dataset** list, choose **Layered Material 2**.

*Surface 1*

1 Right-click **Temperature (Layers Surface)** and choose **Surface**.

- 2 In the **Settings** window for **Surface**, locate the **Coloring and Style** section.
- 3 From the **Color table** list, choose **HeatCameraLight**.
- 4 In the **Temperature (Layers Surface)** toolbar, click  **Plot**.

For a better rendering, change the scaling factor for the thickness of the layers in the **Layered Material 2** dataset.

#### *Layered Material 2*

- 1 In the **Model Builder** window, expand the **Results > Datasets** node, then click **Layered Material 2**.
- 2 In the **Settings** window for **Layered Material**, locate the **Layers** section.
- 3 In the **Scale** text field, type 20.
- 4 Click  **Plot**.

#### *Temperature (Layers Surface)*

- 1 In the **Model Builder** window, under **Results > 2D With Extra Dimension Approach** click **Temperature (Layers Surface)**.
- 2 In the **Settings** window for **3D Plot Group**, locate the **Plot Settings** section.
- 3 From the **View** list, choose **New view**.

#### *2D With Extra Dimension Approach*



Next, create a plot for the temperature on slices of the thermal barrier.

#### *Temperature (Slices)*

- 1 In the **Results** toolbar, click  **3D Plot Group**.
- 2 In the **Settings** window for **3D Plot Group**, type **Temperature (Slices)** in the **Label** text field.
- 3 Locate the **Data** section. From the **Dataset** list, choose **Study 3/Solution 3 (5) (sol3)**.
- 4 Locate the **Plot Settings** section. Clear the **Plot dataset edges** checkbox.
- 5 From the **View** list, choose **New view**.

#### *Layered Material Slice 1*

- 1 Right-click **Temperature (Slices)** and choose **Layered Material Slice**.
- 2 In the **Settings** window for **Layered Material Slice**, locate the **Through-Thickness Location** section.
- 3 From the **Location definition** list, choose **Interfaces**.
- 4 Locate the **Layout** section. From the **Displacement** list, choose **Linear**.
- 5 From the **Orientation** list, choose **x**.

- 6 In the **Relative x-separation** text field, type 0.25.
- 7 Select the **Show descriptions** checkbox.
- 8 In the **Relative separation** text field, type 1.
- 9 Locate the **Coloring and Style** section. From the **Color table** list, choose **HeatCameraLight**.
- 10 In the **Temperature (Slices)** toolbar, click  **Plot**.
- 11 Click the  **Zoom Extents** button in the **Graphics** toolbar.

Next, plot the temperature through the thickness of the thermal barrier.

#### *Temperature (Through Thickness)*

- 1 In the **Results** toolbar, click  **ID Plot Group**.
- 2 In the **Settings** window for **ID Plot Group**, type **Temperature (Through Thickness)** in the **Label** text field.

#### *Line Graph 1*

- 1 Right-click **Temperature (Through Thickness)** and choose **Line Graph**.
- 2 Select Edges 4 and 7 only.
- 3 In the **Settings** window for **Line Graph**, locate the **y-Axis Data** section.
- 4 In the **Expression** text field, type  $z - (2[\text{cm}] - (d_{\text{ceram1}} + d_{\text{ceram2}}) / 2)$ .
- 5 From the **Unit** list, choose **m**.
- 6 Locate the **x-Axis Data** section. From the **Parameter** list, choose **Expression**.

#### *Temperature (Through Thickness)*

In the **Model Builder** window, click **Temperature (Through Thickness)**.

#### *Through Thickness 1*

- 1 In the **Temperature (Through Thickness)** toolbar, click  **More Plots** and choose **Through Thickness**.
- 2 In the **Settings** window for **Through Thickness**, locate the **Data** section.
- 3 From the **Dataset** list, choose **Study 3/Solution 3 (5) (sol3)**.
- 4 Select Point 2 only.
- 5 Locate the **x-Axis Data** section. In the **Expression** text field, type **T2**.
- 6 Click to expand the **Coloring and Style** section. Find the **Line style** subsection. From the **Line** list, choose **None**.
- 7 Find the **Line markers** subsection. From the **Marker** list, choose **Cycle**.
- 8 From the **Positioning** list, choose **Interpolated**.

9 Locate the **y-Axis Data** section. Find the **Interface positions** subsection. From the **Show interface positions** list, choose **All interfaces**.

10 In the **Temperature (Through Thickness)** toolbar, click  **Plot**.

Finally, evaluate the average temperature in the thermal barrier and in each of its layers by making a **Global Evaluation** of the variables defined previously in each component.

#### *Global Evaluation 1*

- 1 In the **Results** toolbar, click  **Global Evaluation**.
- 2 In the **Settings** window for **Global Evaluation**, click **Replace Expression** in the upper-right corner of the **Expressions** section. From the menu, choose **Component 1 (comp1) > Definitions > Variables > T\_ave\_barrier - Average of temperature in thermal barrier - K**.
- 3 Click **Add Expression** in the upper-right corner of the **Expressions** section. From the menu, choose **Component 1 (comp1) > Definitions > Variables > T\_ave\_layer1 - Average of temperature in layer 1 - K**.
- 4 Click **Add Expression** in the upper-right corner of the **Expressions** section. From the menu, choose **Component 1 (comp1) > Definitions > Variables > T\_ave\_layer2 - Average of temperature in layer 2 - K**.
- 5 Locate the **Expressions** section. In the table, enter the following settings:

Expression	Unit	Description
T_ave_barrier	degC	Average of temperature in thermal barrier
T_ave_layer1	degC	Average of temperature in layer 1
T_ave_layer2	degC	Average of temperature in layer 2

6 Click  **Evaluate**.

#### *Global Evaluation 2*

- 1 In the **Results** toolbar, click  **Global Evaluation**.
- 2 In the **Settings** window for **Global Evaluation**, locate the **Data** section.
- 3 From the **Dataset** list, choose **Study 3/Solution 3 (5) (sol3)**.
- 4 Click **Replace Expression** in the upper-right corner of the **Expressions** section. From the menu, choose **Component 2 (comp2) > Definitions > Variables > T\_ave\_barrier - Average of temperature in thermal barrier - K**.
- 5 Click **Add Expression** in the upper-right corner of the **Expressions** section. From the menu, choose **Component 2 (comp2) > Definitions > Variables > T\_ave\_layer1 - Average of temperature in layer 1 - K**.

6 Click **Add Expression** in the upper-right corner of the **Expressions** section. From the menu, choose **Component 2 (comp2) > Definitions > Variables > T\_ave\_layer2 - Average of temperature in layer 2 - K**.

7 Locate the **Expressions** section. In the table, enter the following settings:

<b>Expression</b>	<b>Unit</b>	<b>Description</b>
T_ave_barrier	degC	Average of temperature in thermal barrier
T_ave_layer1	degC	Average of temperature in layer 1
T_ave_layer2	degC	Average of temperature in layer 2

8 Click  **Evaluate**.

The average temperature is close to 530°C in the thermal barrier, with some noticeable difference between the two layers.