



Model created in COMSOL Multiphysics 6.4

Convection Cooling of Circuit Boards – 3D Natural Convection

Introduction

This example models the air cooling of circuit boards populated with multiple integrated circuits (ICs), which act as heat sources. Two possible cooling scenarios are shown in [Figure 1](#): vertically aligned boards using natural convection, and horizontal boards with forced convection (fan cooling). In this case, contributions caused by the induced (forced) flow of air dominate the cooling. To achieve high accuracy, the simulation models heat transport in combination with the fluid flow.

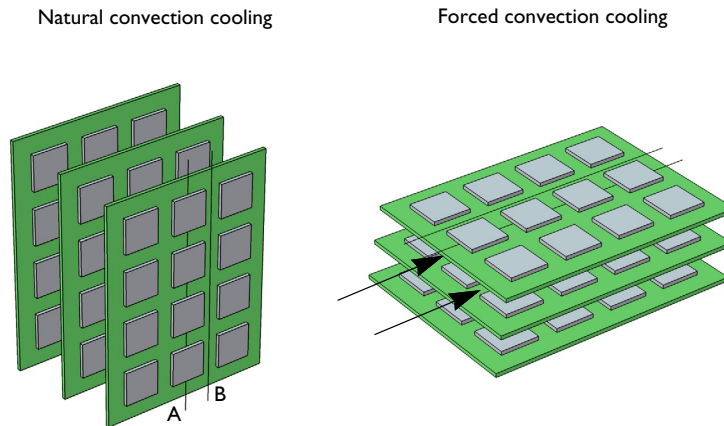

Figure 1: Stacked circuit boards with multiple in-line heat sources. Line A represents the centerline of the row of ICs, and the area between lines A–B on the board represents the symmetry.

A common technique is to describe convective heat flux with a film-resistance coefficient, h . The heat-transfer equations then become simple to solve. However, this simplification requires that the coefficient is well determined which is difficult for many systems and conditions.

An alternative way to thoroughly describe the convective heat transfer is to model the heat transfer in combination with the fluid-flow field. The results then accurately describe the heat transport and temperature changes. From such simulations it is also possible to derive accurate estimations of the film coefficients. Such models are somewhat more complex but they are useful for unusual geometries and complex flows. The following example models the heat transfer of a circuit-board assembly using the Conjugate Heat Transfer predefined

multiphysics coupling of the Heat Transfer Module. The modeled scenario is based on work published by A. Ortega (Ref. 1).

FR4 circuit board material (Ref. 2) and silicon are used as the solid materials composing the circuit board system. The model treats air properties as temperature dependent.

The dimensions of the original geometry are:

- Board: length (in the flow direction) 130 mm, and the thickness is 2 mm
- ICs: length and width are both 20 mm, and thickness is 2 mm
- The boards are spaced 10 mm apart

Model Definition

This example simulates natural convection cooling of a vertical circuit board as shown in Figure 1. Due to symmetry, it is sufficient to model a unit cell, from the back side of a board to the next back side, covering the area between lines A and B in Figure 1. Figure 2 depicts the three-dimensional geometry.

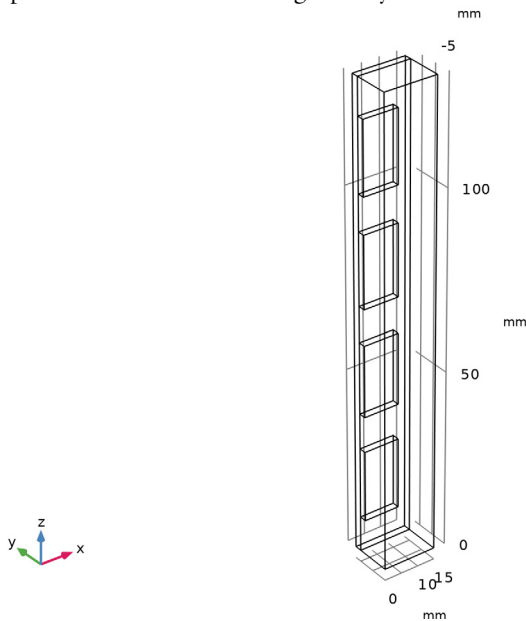

Figure 2: The modeled geometry.

The model makes use of the Conjugate Heat Transfer predefined multiphysics coupling with a stationary study to set up the simulation. The heat rate per unit volume is

1.25 MW/m^3 . Due to heating of the fluid, deviations occur in the local density, ρ , compared to the inlet density, ρ_{ref} . This results in a local buoyancy force defined using the **Gravity** feature in the **Single Phase Flow** interface.

Results and Discussion

The temperature distribution is shown in [Figure 3](#). The temperature increase at the hottest spot of each component computed in this 3D model is approximately two degrees higher than that for the 2D model (see [Convection Cooling of Circuit Boards — 2D Natural Convection](#) for 2D model description and results). In addition, the temperature difference among the various ICs is smaller in the 3D model, which predicts a more uniform temperature rise of the ICs. The ICs have an operating temperature between 50 K and 100 K above ambient. This result is closer to reality compared to the 2D simulation because it also includes the horizontal gaps between the ICs.

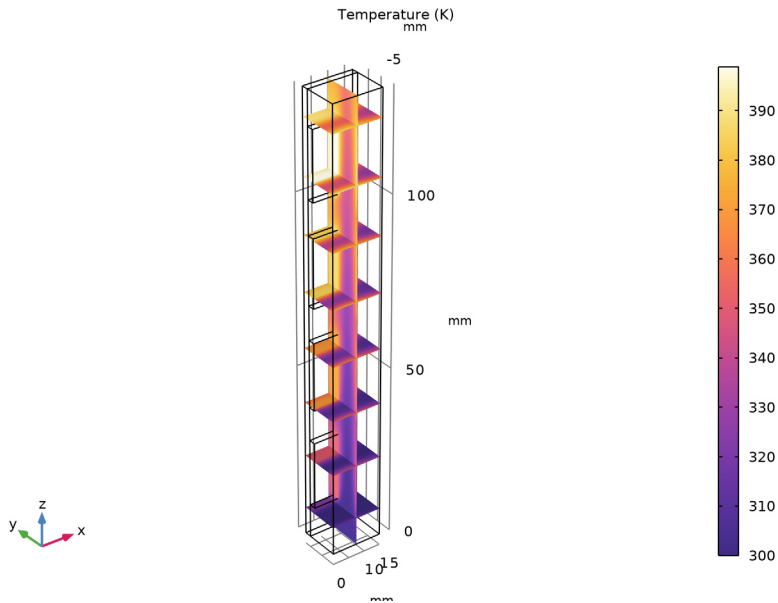

Figure 3: Temperature distribution for the 3D model.

The difference in temperature rise along the board's height is explained primarily by the fluid-flow pattern ([Figure 4](#)). The maximum fluid velocity is slightly higher for the 3D case than for the 2D case. More importantly, the flow field behaves differently in the 3D case. When making a comparison between the 2D and 3D models, it can be noticed that the

velocity fields are rather similar along the centerline of the heat sources. However, there is a channeling effect from the horizontal gaps.

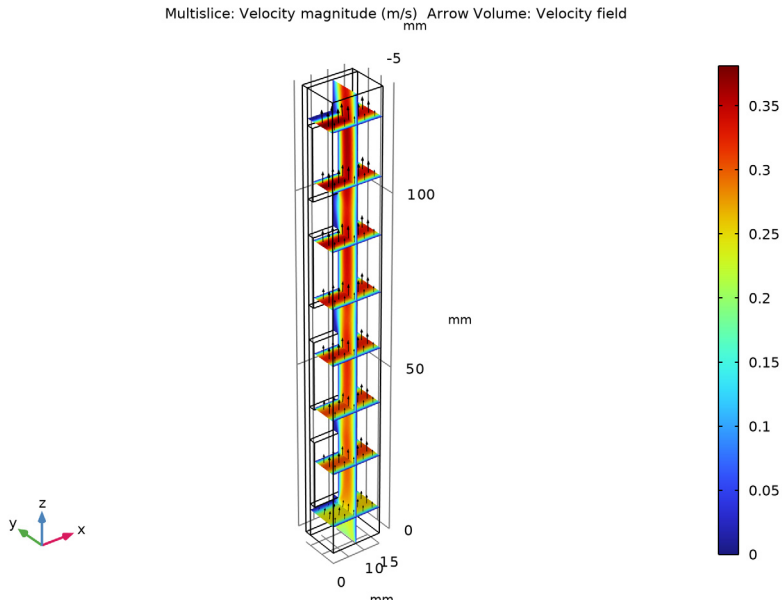

Figure 4: Velocity field distribution.

References

1. A. Ortega, “Air Cooling of Electronics: A Personal Perspective 1981-2001,” presentation material, *IEEE SMITHERM* Symposium, 2002.
2. C. Bailey, “Modeling the Effect of Temperature on Product Reliability,” Proc. 19th *IEEE SMITHERM* Symposium, 2003.

Application Library path: Heat_Transfer_Module/
Power_Electronics_and_Electronic_Cooling/circuit_board_nat_3d



Modeling Instructions

From the **File** menu, choose **New**.

NEW

In the **New** window, click  **Model Wizard**.

MODEL WIZARD

- 1 In the **Model Wizard** window, click  **3D**.
- 2 In the **Select Physics** tree, select **Heat Transfer > Conjugate Heat Transfer > Laminar Flow**.
- 3 Click **Add**.
- 4 Click  **Study**.
- 5 In the **Select Study** tree, select **General Studies > Stationary**.
- 6 Click  **Done**.

GLOBAL DEFINITIONS

Parameters 1

- 1 In the **Model Builder** window, under **Global Definitions** click **Parameters 1**.
- 2 In the **Settings** window for **Parameters**, locate the **Parameters** section.
- 3 In the table, enter the following settings:

Name	Expression	Value	Description
q_source	$1[\text{W}] / (20 \times 20 \times 2[\text{mm}^3])$	1.25E6 W/m ³	Heating power per unit volume
T0	300[K]	300 K	External air temperature
patm	1[atm]	1.0133E5 Pa	Air pressure

GEOMETRY 1

- 1 In the **Model Builder** window, under **Component 1 (comp1)** click **Geometry 1**.
- 2 In the **Settings** window for **Geometry**, locate the **Units** section.
- 3 From the **Length unit** list, choose **mm**.

Block 1 (blk1)



- 1 In the **Geometry** toolbar, click  **Block**.
- 2 In the **Settings** window for **Block**, locate the **Size and Shape** section.
- 3 In the **Width** text field, type 15.
- 4 In the **Depth** text field, type 12.
- 5 In the **Height** text field, type 130.
- 6 Locate the **Position** section. In the **y** text field, type -10.

- 7 Click to expand the **Layers** section. Find the **Layer position** subsection. Select the **Front** checkbox.
- 8 Clear the **Bottom** checkbox.
- 9 In the table, enter the following settings:



Layer name	Thickness (mm)
Layer 1	10

- 10 In the **Geometry** toolbar, click  **Build All**.

Block 2 (blk2)

- 1 In the **Geometry** toolbar, click  **Block**.
- 2 In the **Settings** window for **Block**, locate the **Size and Shape** section.
- 3 In the **Width** text field, type 10.
- 4 In the **Depth** text field, type 2.
- 5 In the **Height** text field, type 20.
- 6 Locate the **Position** section. In the **y** text field, type -2.
- 7 In the **z** text field, type 10.
- 8 In the **Geometry** toolbar, click  **Build All**.

Array 1 (arr1)



- 1 In the **Geometry** toolbar, click  **Transforms** and choose **Array**.
- 2 Select the object **blk2** only.
- 3 In the **Settings** window for **Array**, locate the **Size** section.
- 4 In the **z size** text field, type 4.
- 5 Locate the **Displacement** section. In the **z** text field, type 30.
- 6 In the **Geometry** toolbar, click  **Build All**.
- 7 Click the  **Wireframe Rendering** button in the **Graphics** toolbar.

DEFINITIONS

IC

- 1 In the **Definitions** toolbar, click  **Explicit**.
- 2 In the **Settings** window for **Explicit**, type IC in the **Label** text field.
- 3 Select Domains 2–5 only.

ADD MATERIAL

- 1 In the **Materials** toolbar, click  **Add Material** to open the **Add Material** window.
- 2 Go to the **Add Material** window.
- 3 In the tree, select **Built-in > Air**.
- 4 Click the **Add to Component** button in the window toolbar.
- 5 In the tree, select **Built-in > Silicon**.
- 6 Click the **Add to Component** button in the window toolbar.
- 7 In the tree, select **Built-in > FR4 (Circuit Board)**.
- 8 Click the **Add to Component** button in the window toolbar.
- 9 In the **Materials** toolbar, click  **Add Material** to close the **Add Material** window.

MATERIALS

Air (mat1)

- 1 Select Domain 1 only.
- 2 In the **Settings** window for **Material**, locate the **Geometric Entity Selection** section.
- 3 Click  **Create Selection**.
- 4 In the **Create Selection** dialog, type **Air** in the **Selection name** text field.
- 5 Click **OK**.

Silicon (mat2)

- 1 In the **Model Builder** window, click **Silicon (mat2)**.
- 2 In the **Settings** window for **Material**, locate the **Geometric Entity Selection** section.
- 3 From the **Selection** list, choose **IC**.

FR4 (Circuit Board) (mat3)

- 1 In the **Model Builder** window, click **FR4 (Circuit Board) (mat3)**.
- 2 Select Domain 6 only.

LAMINAR FLOW (SPF)

- 1 In the **Model Builder** window, under **Component 1 (comp1)** click **Laminar Flow (spf)**.
- 2 In the **Settings** window for **Laminar Flow**, locate the **Domain Selection** section.
- 3 From the **Selection** list, choose **Air**.
- 4 Locate the **Physical Model** section. Select the **Include gravity** checkbox.

Open Boundary 1

- 1 In the **Physics** toolbar, click  **Boundaries** and choose **Open Boundary**.
- 2 Select Boundaries 3 and 4 only.

Symmetry 1

- 1 In the **Physics** toolbar, click  **Boundaries** and choose **Symmetry**.
- 2 Select Boundaries 1 and 34 only.

HEAT TRANSFER IN SOLIDS AND FLUIDS (HT)

- 1 In the **Model Builder** window, under **Component 1 (comp1)** click **Heat Transfer in Solids and Fluids (ht)**.
- 2 In the **Settings** window for **Heat Transfer in Solids and Fluids**, locate the **Physical Model** section.
- 3 In the T_{ref} text field, type T0.

Fluid 1

- 1 In the **Model Builder** window, under **Component 1 (comp1)** > **Heat Transfer in Solids and Fluids (ht)** click **Fluid 1**.
- 2 In the **Settings** window for **Fluid**, locate the **Domain Selection** section.
- 3 From the **Selection** list, choose **Air**.

Heat Source 1

- 1 In the **Physics** toolbar, click  **Domains** and choose **Heat Source**.
- 2 In the **Settings** window for **Heat Source**, locate the **Domain Selection** section.
- 3 From the **Selection** list, choose **IC**.
- 4 Locate the **Heat Source** section. In the Q_0 text field, type q_{source} .

Initial Values 1

- 1 In the **Model Builder** window, click **Initial Values 1**.
- 2 In the **Settings** window for **Initial Values**, locate the **Initial Values** section.
- 3 In the T text field, type T0.

Open Boundary 1

- 1 In the **Physics** toolbar, click  **Boundaries** and choose **Open Boundary**.
- 2 Select Boundaries 3 and 4 only.
- 3 In the **Settings** window for **Open Boundary**, locate the **Upstream Properties** section.
- 4 In the T_{ustr} text field, type T0.

Periodic Condition 1

- 1 In the **Physics** toolbar, click  **Boundaries** and choose **Periodic Condition**.
- 2 Select Boundaries 2 and 29 only.



MESH 1

In the **Model Builder** window, under **Component 1 (comp1)** right-click **Mesh 1** and choose **Build All**.

STUDY 1



Modify the default solver suggestion to improve convergence.

Solution 1 (sol1)

- 1 In the **Study** toolbar, click  **Show Default Solver**.
- 2 In the **Model Builder** window, expand the **Solution 1 (sol1)** node.
- 3 In the **Model Builder** window, expand the **Study 1 > Solver Configurations > Solution 1 (sol1) > Stationary Solver 1** node, then click **Fully Coupled 1**.
- 4 In the **Settings** window for **Fully Coupled**, click to expand the **Method and Termination** section.
- 5 In the **Maximal tolerance** text field, type 0.1.
- 6 In the **Study** toolbar, click  **Compute**.

This default plot shows the temperature distribution in the volume. To reproduce [Figure 3](#), do as follows.

RESULT TEMPLATES

- 1 In the **Results** toolbar, click  **Result Templates** to open the **Result Templates** window.
- 2 Go to the **Result Templates** window.
- 3 In the tree, select **Study 1/Solution 1 (sol1) > Heat Transfer in Solids and Fluids > Temperature, Multislice (ht)**.
- 4 Click the **Add Result Template** button in the window toolbar.
- 5 In the **Results** toolbar, click  **Result Templates** to close the **Result Templates** window.

RESULTS

Multislice 1

- 1 In the **Model Builder** window, expand the **Temperature, Multislice (ht)** node, then click **Multislice 1**.
- 2 In the **Settings** window for **Multislice**, locate the **Multiplane Data** section.

- 3 Find the **y-planes** subsection. In the **Planes** text field, type 0.
- 4 Find the **z-planes** subsection. In the **Planes** text field, type 8.
- 5 In the **Temperature, Multislice (ht)** toolbar, click  **Plot**.

Velocity (spf)

This default plot group shows the velocity magnitude on slices.

Modify this plot group to reproduce [Figure 4](#).



Multislice 1

- 1 In the **Model Builder** window, expand the **Velocity (spf)** node, then click **Multislice 1**.
- 2 In the **Settings** window for **Multislice**, click **Replace Expression** in the upper-right corner of the **Expression** section. From the menu, choose **Component 1 (comp1) > Laminar Flow > Velocity and pressure > spf.U - Velocity magnitude - m/s**.
- 3 Locate the **Multipane Data** section. Find the **y-planes** subsection. In the **Planes** text field, type 0.
- 4 Find the **z-planes** subsection. In the **Planes** text field, type 8.

Velocity (spf)

In the **Model Builder** window, click **Velocity (spf)**.

Arrow Volume 1

- 1 In the **Velocity (spf)** toolbar, click  **Arrow Volume**.
- 2 In the **Settings** window for **Arrow Volume**, click **Replace Expression** in the upper-right corner of the **Expression** section. From the menu, choose **Component 1 (comp1) > Laminar Flow > Velocity and pressure > u,v,w - Velocity field**.
- 3 Locate the **Arrow Positioning** section. Find the **x grid points** subsection. In the **Points** text field, type 5.
- 4 Find the **y grid points** subsection. In the **Points** text field, type 5.
- 5 Find the **z grid points** subsection. In the **Points** text field, type 8.
- 6 Locate the **Coloring and Style** section. From the **Color** list, choose **Black**.
- 7 In the **Velocity (spf)** toolbar, click  **Plot**.