



Model created in COMSOL Multiphysics 6.4

# Radiative Heat Transfer in a Utility Boiler

## *Introduction*

---

In recent years, many studies have been conducted in the field of performance optimization of large power plant boilers. The main aims have been to extend the lifetime, increase the thermal efficiency, and reduce the pollutant emissions of the boilers. A good furnace design is the most important part in the energy conversion process in the boilers. A furnace is where the fuel is burnt and the chemical energy is converted into heat to be transferred into the water walls of steam boilers. The temperatures in fuel furnaces are high enough that the radiation becomes the most important mechanism in heat transfer. Due to complexity of the radiation mechanism and its dependence on the enclosure's geometry, there is no analytical solution except for very simple problems. This fact along with expensive experimental modeling leads researchers to develop numerical models for analyzing these enclosures. Three of the most attractive methods, as far as accuracy and computational requirement are concerned, are the discrete transfer, the discrete ordinates and the finite-volume methods.

---

**Note:** Solving this application requires approximately 5 GB of memory.

---

## *Model Definition*

---

Of practical relevance is the radiative heat transfer in furnaces containing obstacles, such as protrusions and obstructions. In some applications, the thickness of the obstacles is very small as it occurs in utility boilers, where panels are often hanged in the radiation chamber.

In order to reduce the mesh (and then the computational cost), these obstructions are modeled as baffles (zero thickness). This study handles zero thickness obstacles containing an emitting-absorbing medium.

A three-dimensional enclosure resembling the combustion chamber of a utility boiler is modeled. The study takes advantage of symmetries to model only one half of the combustion chamber, thereby reducing model size and computational costs. The

enclosure contains three baffles, as shown in [Figure 1](#), which simulates the panels of superheaters suspended at the top of the combustion chamber.

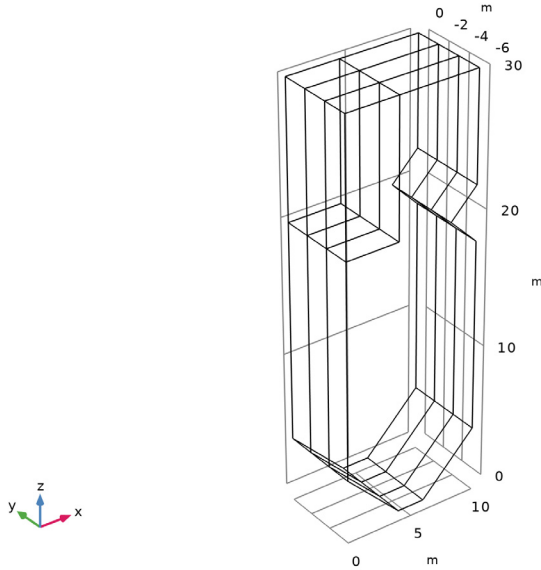

*Figure 1: Half of the utility boiler with obstructions.*

In this example, the S4 discrete ordinates method was employed for predicting the heat flux on the side walls of enclosures and incident radiation distribution within the furnace. It results in a set of 24 discrete directions to represent radiative intensity transport.

The main assumption is using an existing uniform temperature and properties within the volume and surface zones, as proposed in [Ref. 1](#). The temperature and emissivity of the boundaries, including the surface of the baffles, are taken as 800 K and 0.65, respectively, except at  $x = 10$  m and for  $22 \leq z \leq 30$  m, where the temperature was set equal to 1200 K and a blackbody surface is assumed. An emitting-absorbing medium is assumed, with the following distribution of temperature and absorption coefficient:

TABLE I: DISTRIBUTION OF TEMPERATURE AND ABSORPTION COEFFICIENT.

Coordinate (m)	Absorption coefficient (1/m)	Temperature (K)
$z \leq 5$	0.20	1600
$5 < z \leq 10$	0.25	2000

TABLE 1: DISTRIBUTION OF TEMPERATURE AND ABSORPTION COEFFICIENT.

Coordinate (m)	Absorption coefficient (1/m)	Temperature (K)
$10 < z \leq 20$	0.20	1600
$20 < z \leq 30$	0.18	1200

### THERMAL ANALYSIS

The discrete-ordinates method (DOM) relies on the discrete representation of the directional dependence of the radiation intensity. The radiative transfer equation (RTE) is solved for a set of discrete directions,  $s_i$ , which span the total solid angle range of  $4\pi$  around a point in space.

The RTE for this type of configuration can be written as:

$$s \cdot \nabla I(r, s) = \kappa I_b(T) - \beta I(r, s) + \frac{\sigma_s}{4\pi} \int_0^{4\pi} I(r, s') \phi(r, s', s) d\Omega'$$

where

- $I(r, s)$  is the radiative intensity at a given position  $r$ , following  $s$  direction
- $T$  is the temperature
- $\kappa, \beta, \sigma_s$  are absorption, extinction, and scattering coefficients, respectively
- $I_b(T)$  is the blackbody radiative intensity
- $\phi(r, s', s)$  is the scattering function.  $\phi(r, s', s) = 1 + a_1 \mu_0$  and  $\mu_0 = s' \cdot s$  is the cosine of the scattering angle.

The boundary intensities in the furnace walls are given physically by the effective emitted intensity plus reflected incident intensities into a respective direction.

$$I_{\text{bnd}}(r, s) = \epsilon_w I_b(T) + \frac{\rho_d}{\pi} q_{\text{out}} \quad \text{for all } s \text{ such that } \mathbf{n} \cdot s < 0$$

where

- $\epsilon_w$  is the surface emissivity, which is in the range  $[0, 1]$
- $\rho_d = 1 - \epsilon_w$  is the diffusive reflectivity
- $\mathbf{n}$  is the outward normal vector
- $q_{\text{out}}$  is the heat flux striking the wall:

$$q_{\text{out}} = \int_{(\mathbf{n} \cdot s' > 0)} (\mathbf{n} \cdot s') I(r, s') d\Omega'$$

The above equations can be discretized in Cartesian coordinates for monochromatic or gray radiation as

$$s_i \cdot \nabla I_i = \kappa I_b(T) - \beta I_i + \frac{\sigma_s}{4\pi} \int_0^{4\pi} I(r, s') \phi(r, s', s) d\Omega'$$

The Sn approximation of the RTE in the  $m$  direction can be expressed as

$$s_i \cdot \nabla I_i = \kappa I_b(T) - \beta I_i + \frac{\sigma_s}{4\pi} \sum_{j=1}^n w_j I_j \phi(r, s_j, s_i)$$

For a discrete direction,  $s_i$ , the values of  $s_{i,1}$ ,  $s_{i,2}$ , and  $s_{i,3}$  define the direction cosines of  $s_i$  obeying the condition  $s_{i,1}^2 + s_{i,2}^2 + s_{i,3}^2 = 1$ . The  $j$  index in the above equation denotes the direction of incoming radiation contributing to the direction  $s_i$ .

For a diffuse reflecting surface on a wall boundary, the boundary condition equation is transformed as

$$I_{i, \text{bnd}} = \epsilon_w I_b(T) + \frac{\rho_d}{\pi} \sum_{(\mathbf{n} \cdot s_j > 0)} w_j I_j (\mathbf{n} \cdot s_j) \quad \text{for all } s_i \text{ such that } \mathbf{n} \cdot s_i < 0$$

## *Results and Discussion*

---

Figure 2 and Figure 3 show the predicted incident radiation surface plots. The maximum incident radiation occurs at the level where the temperature and absorbing coefficient of the medium are the highest (that is, at the boiler's burner level).

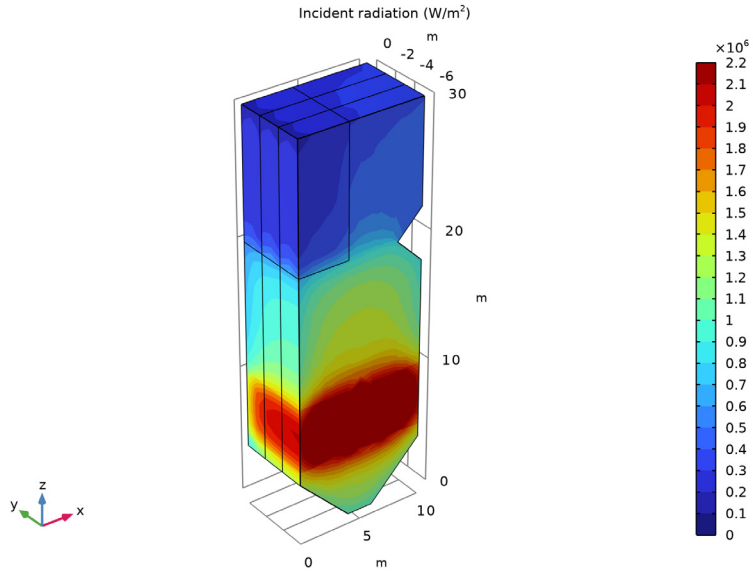

Figure 2: Incident radiation.

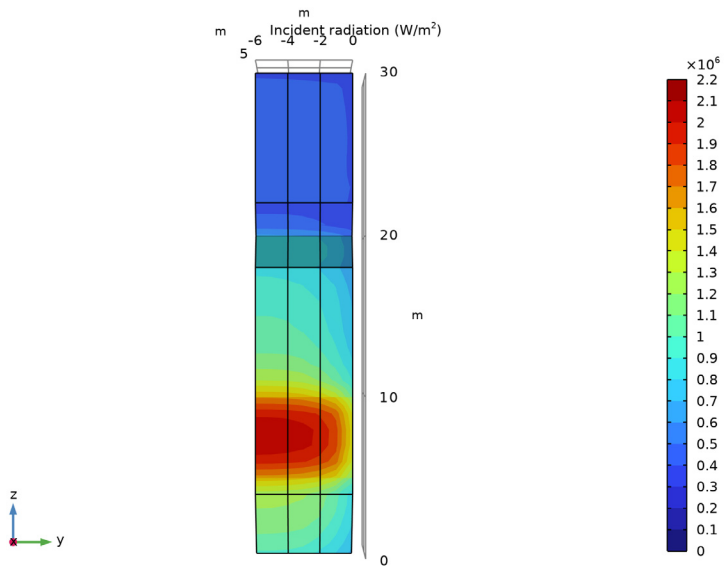

Figure 3: Incident radiation on the front of the boiler ( $\text{W/m}^2$ ).

The predicted outgoing heat flux is shown in Figure 4 and is in good agreement with published data (Ref. 1).

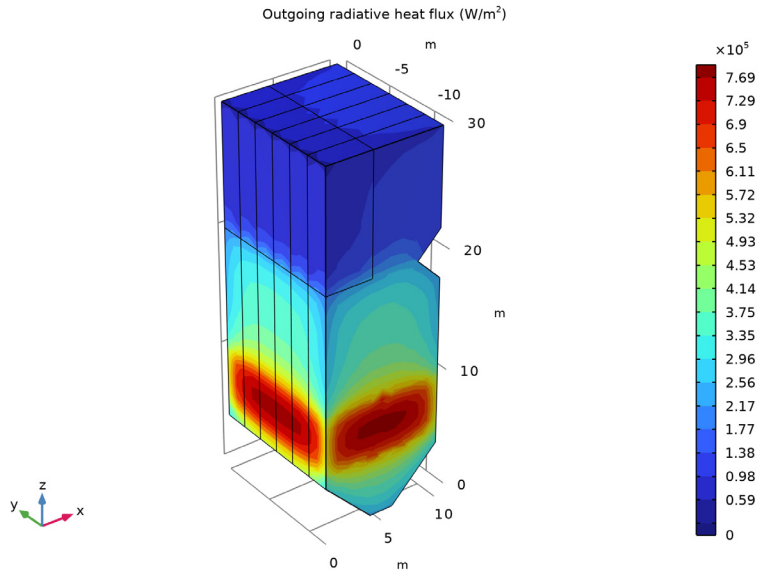

Figure 4: Outgoing heat flux on walls of the boiler (W/m<sup>2</sup>).

### Reference

1. P.J. Coelho, J.M. Goncalves, and M.G. Carvalho, "Modelling of Radiative Heat Transfer in Enclosures with Obstacles," *Int'l J. Heat and Mass Transfer*, vol. 41, no. 4–5, pp. 745–756, 1998.

---

**Application Library path:** Heat\_Transfer\_Module/Thermal\_Radiation/boiler

---



### Modeling Instructions

From the **File** menu, choose **New**.

#### **NEW**

In the **New** window, click  **Model Wizard**.

## MODEL WIZARD

- 1 In the **Model Wizard** window, click  **3D**.
- 2 In the **Select Physics** tree, select **Heat Transfer > Radiation > Radiation in Participating Media (rpm)**.
- 3 Click **Add**.
- 4 Click  **Study**.
- 5 In the **Select Study** tree, select **General Studies > Stationary**.
- 6 Click  **Done**.

## GLOBAL DEFINITIONS

### *Parameters I*

- 1 In the **Model Builder** window, under **Global Definitions** click **Parameters I**.
- 2 In the **Settings** window for **Parameters**, locate the **Parameters** section.
- 3 In the table, enter the following settings:

Name	Expression	Value	Description
Thot	1200[K]	1200 K	Temperature, hot surface zone
Tlow	800[K]	800 K	Temperature, cool surfaces
em	0.65	0.65	Emissivity, cool surfaces
scattC	0[1/m]	0 1/m	Scattering coefficient

### *Piecewise I (pwl)*

- 1 In the **Home** toolbar, click  **Functions** and choose **Global > Piecewise**.
- 2 In the **Settings** window for **Piecewise**, type T in the **Function name** text field.
- 3 Locate the **Definition** section. In the **Argument** text field, type z.
- 4 Find the **Intervals** subsection. In the table, enter the following settings:

Start	End	Function
0	5	1600
5	10	2000
10	20	1600
20	30	1200

- 5 Locate the **Units** section. In the **Arguments** text field, type m.
- 6 In the **Function** text field, type K.

### Piecewise 2 (pw2)



- 1 In the **Home** toolbar, click  **Functions** and choose **Global > Piecewise**.
- 2 In the **Settings** window for **Piecewise**, type  $\text{abs}C$  in the **Function name** text field.
- 3 Locate the **Definition** section. In the **Argument** text field, type  $z$ .
- 4 Find the **Intervals** subsection. In the table, enter the following settings:

Start	End	Function
0	5	0.20
5	10	0.25
10	20	0.20
20	30	0.18



- 5 Locate the **Units** section. In the **Arguments** text field, type  $m$ .
- 6 In the **Function** text field, type  $1/m$ .

## GEOMETRY I

### Work Plane 1 (wp1)

- 1 In the **Geometry** toolbar, click  **Work Plane**.
- 2 In the **Settings** window for **Work Plane**, locate the **Plane Definition** section.
- 3 From the **Plane** list, choose **xz-plane**.
- 4 Click  **Go to Plane Geometry**.

### Work Plane 1 (wp1) > Polygon 1 (pol1)

- 1 In the **Work Plane** toolbar, click  **Polygon**.
- 2 In the **Settings** window for **Polygon**, locate the **Coordinates** section.
- 3 From the **Data source** list, choose **Vectors**.
- 4 In the **xw** text field, type 0 0 0 10 10 10 10 8 8 10 10 10 10 6 6 4 4 0.
- 5 In the **yw** text field, type 4 30 30 30 30 22 22 20 20 18 18 4 4 0 0 0 0 4.
- 6 In the **Work Plane** toolbar, click  **Build All**.

### Work Plane 1 (wp1) > Rectangle 1 (r1)



- 1 In the **Work Plane** toolbar, click  **Rectangle**.
- 2 In the **Settings** window for **Rectangle**, locate the **Size and Shape** section.
- 3 In the **Width** text field, type 4.
- 4 In the **Height** text field, type 10.

- 5 Locate the **Position** section. In the **yw** text field, type 20.
- 6 In the **Work Plane** toolbar, click  **Build All**.

*Extrude 1 (ext1)*

- 1 In the **Model Builder** window, right-click **Geometry 1** and choose **Extrude**.
- 2 In the **Settings** window for **Extrude**, locate the **Distances** section.
- 3 In the table, enter the following settings:

<b>Distances (m)</b>
2
4
6

- 4 In the **Geometry** toolbar, click  **Build All**.
- 5 Click the  **Wireframe Rendering** button in the **Graphics** toolbar.
- 6 Click the  **Zoom Extents** button in the **Graphics** toolbar.

The geometry should correspond to that in [Figure 1](#).

## MATERIALS

Add a material to specify the absorption and scattering coefficients inside the boiler.

*Chamber*

- 1 In the **Materials** toolbar, click  **Blank Material**.
- 2 In the **Settings** window for **Material**, type Chamber in the **Label** text field.
- 3 Locate the **Material Contents** section. In the table, enter the following settings:

<b>Property</b>	<b>Variable</b>	<b>Value</b>	<b>Unit</b>	<b>Property group</b>
Absorption coefficient	kappaR	absC(z)	1/m	Basic
Scattering coefficient	sigmaS	scattC	1/m	Basic

Analogously, specify the emissivity of the boiler walls using a material.

*Walls*

- 1 In the **Materials** toolbar, click  **Blank Material**.
- 2 In the **Settings** window for **Material**, type Walls in the **Label** text field.
- 3 Locate the **Geometric Entity Selection** section. From the **Geometric entity level** list, choose **Boundary**.

4 From the **Selection** list, choose **All boundaries**.

5 Locate the **Material Contents** section. In the table, enter the following settings:

Property	Variable	Value	Unit	Property group
Surface emissivity	epsilon_rad	em		Basic

#### **RADIATION IN PARTICIPATING MEDIA (RPM)**

By default, the **Discrete ordinates method** is **S4**, which corresponds to 24 discrete angular directions.

##### *Participating Medium 1*

1 In the **Model Builder** window, under **Component 1 (comp1)** >

**Radiation in Participating Media (rpm)** click **Participating Medium 1**.

2 In the **Settings** window for **Participating Medium**, locate the **Model Input** section.

3 In the  $T$  text field, type  $T(z)$ .

##### *Initial Values 1*

1 In the **Model Builder** window, click **Initial Values 1**.

2 In the **Settings** window for **Initial Values**, locate the **Initial Values** section.

3 In the  $T_{\text{init}}$  text field, type  $T(z)$ .

##### *Opaque Surface 1*

1 In the **Model Builder** window, click **Opaque Surface 1**.

2 In the **Settings** window for **Opaque Surface**, locate the **Model Input** section.

3 In the  $T$  text field, type  $T_{\text{low}}$ .

##### *Opaque Surface 2*

1 In the **Physics** toolbar, click  **Boundaries** and choose **Opaque Surface**.

2 Select Boundaries 43, 45, and 47 only.

For more convenience in selecting these boundaries, you can click the **Paste Selection** button and paste the above numbers.

3 In the **Settings** window for **Opaque Surface**, locate the **Model Input** section.

4 In the  $T$  text field, type  $T_{\text{hot}}$ .

5 Locate the **Surface Radiative Properties** section. From the **Surface type** list, choose **Black surface**.

##### *Opaque Surface 3*

1 In the **Physics** toolbar, click  **Boundaries** and choose **Opaque Surface**.

- 2 Select Boundaries 12 and 19 only.
- 3 In the **Settings** window for **Opaque Surface**, locate the **Model Input** section.
- 4 In the  $T$  text field, type Tlow.

#### *Opaque Surface 4*



- 1 In the **Physics** toolbar, click  **Boundaries** and choose **Opaque Surface**.
- 2 Select Boundary 5 only.
- 3 In the **Settings** window for **Opaque Surface**, locate the **Model Input** section.
- 4 In the  $T$  text field, type Tlow.
- 5 Locate the **Surface Radiative Properties** section. Select the **Define properties on each side** checkbox.
- 6 Find the **Emissivity** subsection. From the  $\epsilon_u$  list, choose **User defined**.

#### *Symmetry 1*



- 1 In the **Physics** toolbar, click  **Boundaries** and choose **Symmetry**.
- 2 Select Boundary 2 only.

### **MESH 1**

#### *Mapped 1*

- 1 In the **Mesh** toolbar, click  **More Generators** and choose **Mapped**.
- 2 Select Boundary 5 only.
- 3 In the **Settings** window for **Mapped**, click  **Build Selected**.

#### *Free Quad 1*

- 1 In the **Mesh** toolbar, click  **More Generators** and choose **Free Quad**.
- 2 Select Boundary 2 only.
- 3 In the **Settings** window for **Free Quad**, click  **Build Selected**.

#### *Swept 1*

In the **Mesh** toolbar, click  **Swept**.

#### *Size*

- 1 In the **Model Builder** window, click **Size**.
- 2 In the **Settings** window for **Size**, locate the **Element Size** section.
- 3 From the **Predefined** list, choose **Extra fine**.
- 4 In the **Model Builder** window, right-click **Mesh 1** and choose **Build All**.

## STUDY 1

In the **Study** toolbar, click  **Compute**.

## RESULTS

### *Incident Radiation (rpm)*

The default plot group shows the **Incident Radiation** multislice plot. Follow the instructions below to replace the multislice plot for **Incident Radiation** by a contour plot.





#### *Multislice 1*

- 1 In the **Model Builder** window, expand the **Incident Radiation (rpm)** node.
- 2 Right-click **Multislice 1** and choose **Delete**.
- 3 Click **Yes** to confirm.

### *Incident Radiation (rpm)*

In the **Model Builder** window, under **Results** click **Incident Radiation (rpm)**.

#### *Contour 1*

- 1 In the **Incident Radiation (rpm)** toolbar, click  **Contour**.
- 2 In the **Settings** window for **Contour**, locate the **Levels** section.
- 3 From the **Entry method** list, choose **Levels**.
- 4 In the **Levels** text field, type range (0, 1e5, 21e5).
- 5 Locate the **Coloring and Style** section. From the **Contour type** list, choose **Filled**.
- 6 Click to expand the **Quality** section. From the **Evaluation settings** list, choose **Manual**.
- 7 From the **Smoothing** list, choose **None**.
- 8 In the **Incident Radiation (rpm)** toolbar, click  **Plot**.
- 9 Click the  **Zoom Extents** button in the **Graphics** toolbar to get the results shown in [Figure 2](#).
- 10 Click the  **Go to YZ View** button in the **Graphics** toolbar to reproduce the results in [Figure 3](#).

In [Figure 4](#), the outgoing radiative heat flux is plotted for the full 3D geometry. Even if only one half of the utility boiler is modeled the solution can be mirrored to obtain a full 3D view of the results. To do so, follow the steps below:

#### *Mirror 3D 1*

- 1 In the **Model Builder** window, expand the **Results > Datasets** node.
- 2 Right-click **Results > Datasets** and choose **More 3D Datasets > Mirror 3D**.

- 3 In the **Settings** window for **Mirror 3D**, locate the **Plane Data** section.
- 4 From the **Plane** list, choose **XZ-planes**.
- 5 In the **Y-coordinate** text field, type -6.
- 6 Click  **Plot**.

*Outgoing Radiative Heat Flux (rpm)*

- 1 In the **Results** toolbar, click  **3D Plot Group**.
- 2 In the **Settings** window for **3D Plot Group**, type **Outgoing Radiative Heat Flux (rpm)** in the **Label** text field.
- 3 Locate the **Data** section. From the **Dataset** list, choose **Mirror 3D I**.

*Contour 1*

- 1 In the **Outgoing Radiative Heat Flux (rpm)** toolbar, click  **Contour**.
- 2 In the **Settings** window for **Contour**, click **Replace Expression** in the upper-right corner of the **Expression** section. From the menu, choose **Component 1 (comp1) > Radiation in Participating Media > Boundary fluxes > rpm.qr\_out - Outgoing radiative heat flux - W/m<sup>2</sup>**.
- 3 Locate the **Coloring and Style** section. From the **Contour type** list, choose **Filled**.
- 4 Locate the **Quality** section. From the **Evaluation settings** list, choose **Manual**.
- 5 From the **Smoothing** list, choose **None**.

*Outgoing Radiative Heat Flux (rpm)*

Click the  **Go to Default View** button in the **Graphics** toolbar to obtain [Figure 4](#).