



Model created in COMSOL Multiphysics 6.4

Fluid–Structure Interaction in Aluminum Extrusion

Introduction

Out of all metals, the most frequently extruded is aluminum. Aluminum extrusion entails using a hydraulic ram to squeeze an aluminum bar through a die. This process will form the metal into a particular shape. Extruded aluminum is used in many manufacturing applications, such as building components for example. In massive forming processes like rolling or extrusion, metal alloys are deformed in a hot solid state with material flowing under ideally plastic conditions. Such processes can be simulated effectively using computational fluid dynamics, where the material is considered as a fluid with a very high viscosity that depends on velocity and temperature. Internal friction of the moving material acts as a heat source, so that the heat transfer equations are fully coupled with those ruling the fluid dynamics part. This approach is especially advantageous when large deformations are involved.

This model is adapted from a benchmark study in [Ref. 1](#). The original benchmark solves a thermal-structural coupling, because it is common practice in the simulation of such processes to use specific finite element codes that have the capability to couple the structural equations with heat transfer. The alternative scheme discussed here couples non-Newtonian flow with heat transfer equations. In addition, because it is useful to know the stress in the die due to fluid pressure and thermal loads, the model adds a structural mechanics analysis.

The die design is courtesy of Compes S.p.A., while the die geometry, boundary conditions, and experimental data are taken from [Ref. 1](#).

Note: This model requires the Heat Transfer Module and the Structural Mechanics Module. In addition, it uses the Material Library. To create the geometry from scratch, the CAD Import Module or Design Module are required.

Model Definition

The model considers steady-state conditions, assuming a billet of infinite length flowing through the die. In the actual process, the billet is pushed by the ram through the die and its volume is continuously reducing.

[Figure 1](#) shows the original complete geometry with four different profiles. To have a model with reasonable dimensions, consider only a quarter of the original geometry. The

simplification involved in neglecting the differences between the four profiles does not affect the numerical scheme proposed. [Figure 2](#) shows the resulting model geometry.

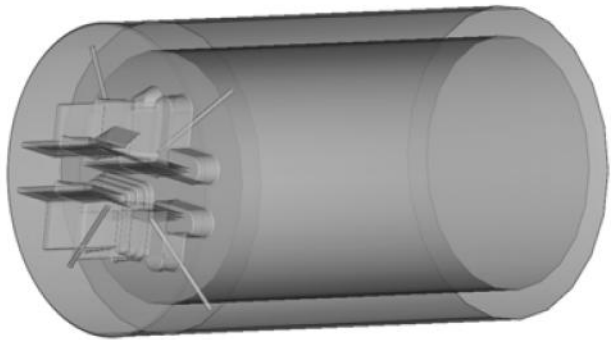

Figure 1: Original benchmark geometry.

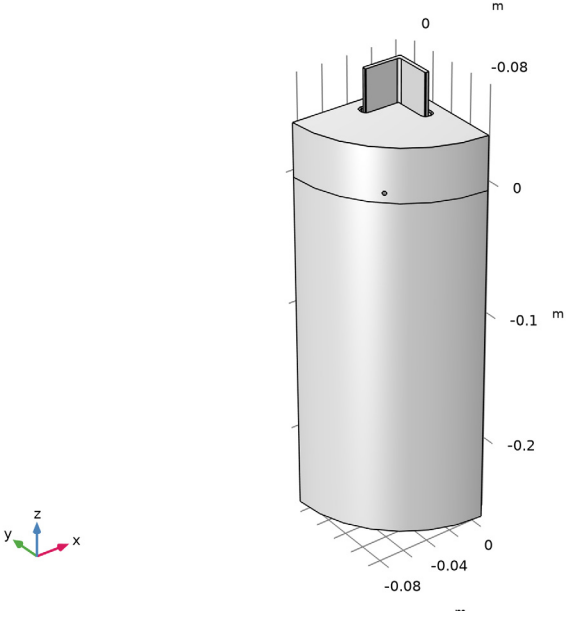

Figure 2: Quarter of the original geometry considered in the model.

MATERIAL PROPERTIES

The documentation for the benchmark model (Ref. 1) serves as the data source for properties of the two main materials: AISI steel for the die and the container (the ram is not considered here) and aluminum for the billet.

Structural Analysis

Because only the steel part is active in the structural analysis, consider a simple linear elastic behavior where the elastic properties are those of the material H11 mod (AISI 610) that can be found in the COMSOL Multiphysics Material Library.

Heat Transfer Analysis

The benchmark model uses the following properties for aluminum and steel:

ALUMINUM	VALUE	DESCRIPTION
k_{al}	210 N/(s·K)	Thermal conductivity
ρ_{al}	2700 kg/m ³	Density
C_{pal}	2.94 N/(mm ² ·K)/ ρ_{al}	Heat capacity at constant pressure
STEEL	VALUE	DESCRIPTION
k_{fe}	24.33 N/(s·K)	Thermal conductivity
ρ_{fe}	7850 kg/m ³	Density
C_{pfe}	4.63 N/(mm ² ·K)/ ρ_{fe}	Heat capacity at constant pressure

Non-Newtonian Flow

The properties of the aluminum were experimentally determined and then checked using literature data for the same alloy and surface state. However the benchmark proposes an experimental constitutive law, suited for the structural mechanics codes usually used to simulate such processes, in the form of the flow stress data. For this model this requires a recalculation of the constitutive law to derive a general expression for the viscosity. The equivalent von Mises stress, σ_{eqv} , can be defined in terms of the total contraction of the deviatoric stress tensor as

$$\sigma_{eqv} = \sqrt{\frac{3}{2}} \tau : \tau$$

or, using $\tau = 2\eta\dot{\epsilon}$ where $\dot{\epsilon}$ is the strain rate and η is the viscosity, as

$$\sigma_{eqv} = \sqrt{6\eta^2 \dot{\epsilon} : \dot{\epsilon}} \quad (1)$$

Introducing the equivalent strain rate

$$\dot{\phi}_{\text{eqv}} \equiv \sqrt{\frac{2}{3} \dot{\boldsymbol{\varepsilon}} : \dot{\boldsymbol{\varepsilon}}}$$

Equation 1 can be expressed as

$$\boldsymbol{\sigma}_{\text{eqv}} = 3\eta \dot{\phi}_{\text{eqv}}$$

The strain rate tensor is defined as (Ref. 2)

$$\dot{\boldsymbol{\varepsilon}} = \frac{\nabla \mathbf{u} + (\nabla \mathbf{u})^T}{2} = \frac{1}{2} \dot{\boldsymbol{\gamma}}$$

The shear rate $\dot{\boldsymbol{\gamma}}$ is defined as

$$\dot{\boldsymbol{\gamma}} = |\dot{\boldsymbol{\gamma}}| = \sqrt{\frac{1}{2} \dot{\boldsymbol{\gamma}} : \dot{\boldsymbol{\gamma}}}$$

so that

$$\dot{\phi}_{\text{eqv}} = \frac{1}{\sqrt{3}} \dot{\boldsymbol{\gamma}}$$

The flow rule

$$\boldsymbol{\sigma}_{\text{eqv}} = \kappa_f$$

states that plastic yielding occurs if the equivalent stress, $\boldsymbol{\sigma}_{\text{eqv}}$, reaches the flow stress, κ_f . The viscosity is defined as (see Ref. 2 for further details)

$$\eta = \frac{\kappa_f}{3\dot{\phi}_{\text{eqv}}}$$

The organizers of the benchmark propose specific flow-stress data expressed in terms of a generalized Zener–Hollomon function

$$\eta = \frac{\text{asinh}\left(\left(\frac{Z}{A}\right)^{\frac{1}{n}}\right)}{\sqrt{3}\alpha\dot{\boldsymbol{\gamma}}}$$

where $A = 2.39 \cdot 10^8 \text{ s}^{-1}$, $n = 2.976$, $\alpha = 0.052 \text{ MPa}^{-1}$, and

$$Z = \frac{1}{\sqrt{3}} \dot{\gamma} e^{\left(\frac{Q}{RT}\right)}$$

with $Q = 153 \text{ kJ/mol}$ and $R = 8.314 \text{ J/(K}\cdot\text{mol)}$.

SOURCES, INITIAL CONDITIONS, AND BOUNDARY CONDITIONS

Structural Analysis

Because the model geometry is a quarter of the actual geometry, use symmetric boundary conditions for the two orthogonal planes. On the external surfaces of the die, apply roller boundary conditions because in reality other dies, not considered here, are present to increase the system's stiffness.

The main loads are the thermal loads from the heat transfer analysis and the total stress from the fluid dynamics analysis.

Heat Transfer Analysis

For the billet, use a volumetric heat source related to the viscous heating effect.

The external temperature of the ram and the die is held constant at 450°C (723 K). The ambient temperature is 25°C (298 K). For the heat exchange between aluminum and steel, use the heat transfer coefficient of $11 \text{ N/(s}\cdot\text{mm}\cdot\text{K)}$. Also consider convective heat exchange with air outside the profiles with a fixed convective heat transfer coefficient of $15 \text{ W/(m}^2\cdot\text{K)}$.

Apply initial temperatures as given in the following table:

PART	VALUE
Ram	380°C (653 K)
Container	450°C (723 K)
Billet	460°C (733 K)
Die	404°C (677 K)

Non-Newtonian Flow

At the inlet, the ram moves with a constant velocity of 0.5 mm/s . Impose this boundary condition by simply applying a constant inlet velocity. At the outlet, a normal stress condition with zero external pressure applies. On the surfaces placed on the two symmetry planes, use symmetric conditions. Finally, apply slip boundary conditions on the boundaries placed outside the profile.

Results and Discussion

The general response of the proposed numerical scheme, especially in the zone of the profile, is in good accordance with the experience of the designers. A comparison between the available experimental data and the numerical results of the simulation shows good agreement.

On the basis of the results from the simulation, the engineer can improve the preliminary die design by adjusting relevant physical parameters and operating conditions. For this purpose, the volume plot in [Figure 3](#) showing the temperature field inside the profile gives important information. Furthermore, the combined streamline and slice plot in [Figure 4](#) reveals any imbalances in the velocity field that could result in a crooked profile. A proper design should also ensure that different parts of the profile travel at the same speed.

[Figure 5](#) shows the von Mises equivalent stress in the steel part considering the thermal load and the pressure load due to the presence of the fluid.

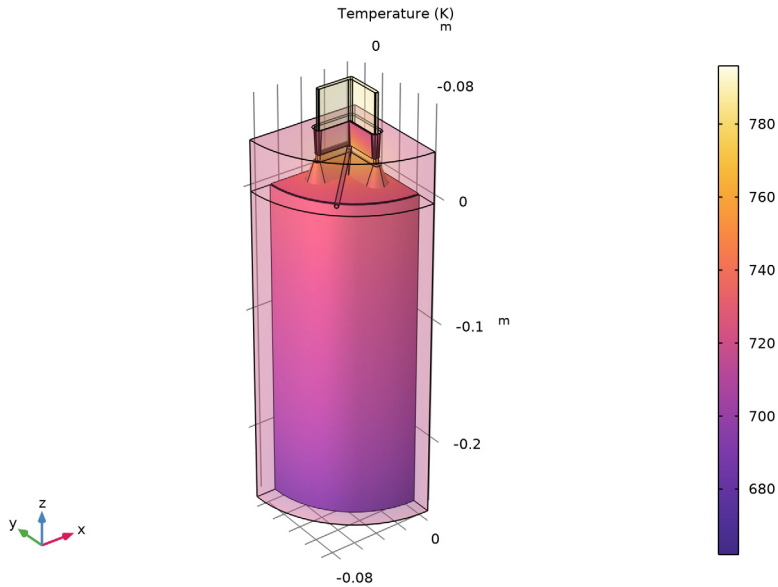

Figure 3: Temperature distribution in the billet.

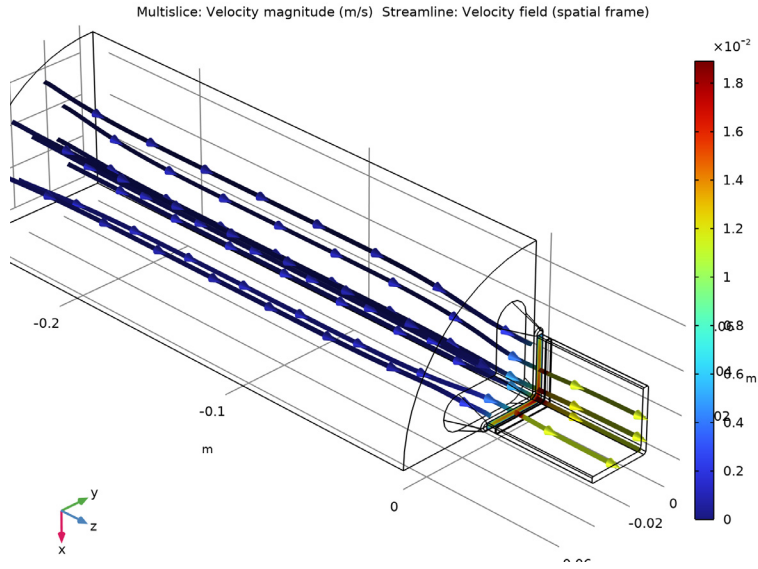

Figure 4: Velocity field and streamlines at the profile section.

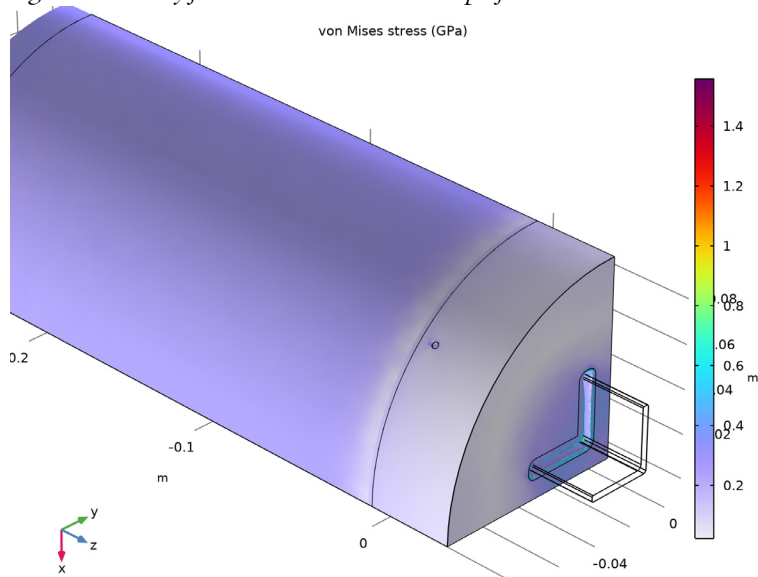

Figure 5: Equivalent von Mises stress distribution in the container.

References

1. M. Schikorra, L. Donati, L. Tomesani, and A.E. Tekkaya, “The Extrusion Benchmark 2007,” *Proceedings of the Extrusion Workshop 2007 and 2nd Extrusion Benchmark Conference*, Bologna, Italy.
2. E.D. Schmitter, “Modelling massive forming processes with thermally coupled fluid dynamics,” *Proceedings of the COMSOL Multiphysics User’s Conference 2005 Frankfurt*, Frankfurt, Germany.

Application Library path: Heat_Transfer_Module/Thermal_Processing/
aluminum_extrusion_fsi



Modeling Instructions

From the **File** menu, choose **New**.

NEW

In the **New** window, click  **Model Wizard**.

MODEL WIZARD

- 1 In the **Model Wizard** window, click  **3D**.
- 2 In the **Select Physics** tree, select **Heat Transfer > Conjugate Heat Transfer > Laminar Flow**.
- 3 Click **Add**.
- 4 In the **Select Physics** tree, select **Structural Mechanics > Solid Mechanics (solid)**.
- 5 Click **Add**.
- 6 Click  **Study**.
- 7 In the **Select Study** tree, select **General Studies > Stationary**.
- 8 Click  **Done**.

GLOBAL DEFINITIONS

Parameters 1

- 1 In the **Model Builder** window, under **Global Definitions** click **Parameters 1**.
- 2 In the **Settings** window for **Parameters**, locate the **Parameters** section.





3 In the table, enter the following settings:

Name	Expression	Value	Description
D_alfe	1[mm]	0.001 m	Thickness of the high conductive layer
Heat_alfe	11[N/(s*mm*K)]	11000 W/(m ² *K)	Aluminum-steel heat exchange coefficient
T_billet	460[degC]	733.15 K	Billet temperature
T_container	450[degC]	723.15 K	Container temperature
T_ram	380[degC]	653.15 K	Ram temperature
T_pd1	404[degC]	677.15 K	Initial temperature around thermocouple at point PD1
V_ram	0.5[mm/s]	5E-4 m/s	Ram velocity
P_init	0[bar]	0 Pa	External reference pressure
T_air	25[degC]	298.15 K	Ambient temperature
Q_eta	153000[J/mol]	1.53E5 J/mol	Parameter Q for the generalized Zener-Hollomon function
n_eta	2.976	2.976	Parameter n for the generalized Zener-Hollomon function
A_eta	2.39e8[1/s]	2.39E8 1/s	Parameter A for the generalized Zener-Hollomon function
alpha_eta	0.0521[1/MPa]	5.21E-8 1/Pa	Parameter alpha for the generalized Zener-Hollomon function
H_conv	15[W/(m ² *K)]	15 W/(m ² *K)	Convective heat exchange coefficient with air
F	sqrt(1/3)	0.57735	Factor for the conversion of the shear rate to COMSOL's definition

GEOMETRY I

The model geometry is provided in a separate MPHBIN file. If you prefer to create it from scratch, follow the steps outlined in the [Geometry Modeling Instructions](#). Note that a license for the CAD Import Module or the Design Module is required to create the geometry. Otherwise, you can import the geometry as follows:

Import 1 (imp1)

- 1 In the **Geometry** toolbar, click  **Import**.
- 2 In the **Settings** window for **Import**, locate the **Source** section.
- 3 Click  **Browse**.
- 4 Browse to the model's Application Libraries folder and double-click the file `aluminum_extrusion_fsi.mphbin`.
- 5 Click  **Import**.
- 6 Click the  **Zoom Extents** button in the **Graphics** toolbar.
- 7 In the **Geometry** toolbar, click  **Build All**.

You should now see the following geometry.

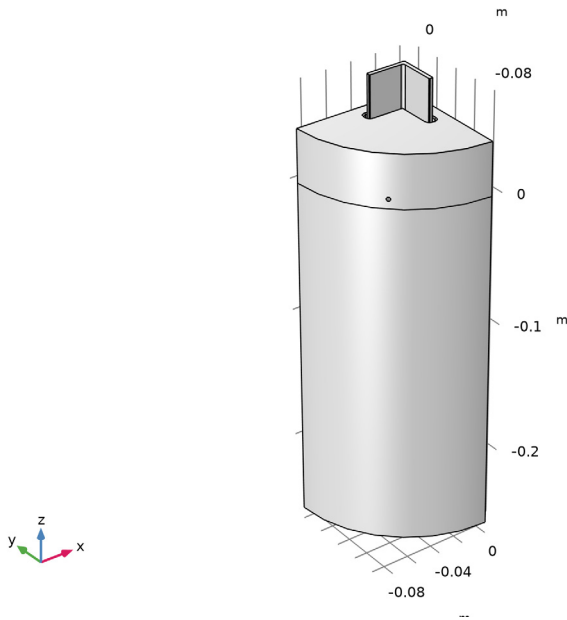

Cleanup Log

- 1 In the **Definitions** toolbar, click  **Local Variables**.
In COMSOL Multiphysics, the automatic detection of small details in the geometry is enabled by default. This feature analyzes the model geometry and uses the **Geometry Cleanup** wizard to remove the small details it detects.
- 2 In the **Geometry Cleanup** dialog that opens, click **Clean Up Automatically** to automatically clean up the geometry.

DEFINITIONS

Variables I

- 1 In the **Model Builder** window, under **Component 1 (comp1) > Definitions** click **Variables I**.
- 2 In the **Settings** window for **Variables**, locate the **Variables** section.
- 3 In the table, enter the following settings:

Name	Expression	Unit	Description
Z_eta	$F \cdot \text{spf} \cdot \text{sr} \cdot \exp(Q_eta / (R_const \cdot T))$	l/s	Zener-Hollomon parameter
mu_al	$\text{asinh}((Z_eta / A_eta)^{(1/n_eta)}) / (3 \cdot \alpha_eta \cdot F \cdot \text{spf} \cdot \text{sr} + \sqrt{\text{eps}})$	Pa·s	Viscosity of aluminum

Create the selections to simplify the model specification.

Outside

- 1 In the **Definitions** toolbar, click  **Explicit**.
- 2 In the **Settings** window for **Explicit**, type **Outside** in the **Label** text field.
- 3 Locate the **Input Entities** section. From the **Geometric entity level** list, choose **Boundary**.
- 4 Select Boundaries 35–38, 42, 43, 50, 51, 53, 55, 70, 71, 79–82, 87, 88, 93, 95, 102, 103, 106, and 108 only.

For more convenience in selecting these boundaries, you can click the **Paste Selection** button and paste the above numbers.

Interior

- 1 In the **Definitions** toolbar, click  **Explicit**.
- 2 In the **Settings** window for **Explicit**, type **Interior** in the **Label** text field.
- 3 Locate the **Input Entities** section. From the **Geometric entity level** list, choose **Boundary**.
- 4 Select Boundaries 8, 11, 14, 15, 19, 20, 24, 29–34, 41, 44, 45, 49, 52, 58–60, 64, 69, 72, 73, 76–78, 86, 89–92, 101, 104, 105, and 109 only.

Before creating the materials for the model, specify the fluid and solid domains. Using this information, the software can detect which material properties are needed.

HEAT TRANSFER IN SOLIDS AND FLUIDS (HT)

Fluid I

- 1 In the **Model Builder** window, under **Component 1 (comp1) > Heat Transfer in Solids and Fluids (ht)** click **Fluid I**.

- 2 Select Domains 3 and 4 only.
- 3 In the **Settings** window for **Fluid**, locate the **Domain Selection** section.
- 4 Click  **Create Selection**.
- 5 In the **Create Selection** dialog, type **Billet** in the **Selection name** text field.
- 6 Click **OK**.

LAMINAR FLOW (SPF)



- 1 In the **Model Builder** window, under **Component 1 (comp1)** click **Laminar Flow (spf)**.
- 2 In the **Settings** window for **Laminar Flow**, locate the **Physical Model** section.
- 3 From the **Compressibility** list, choose **Incompressible flow**.
- 4 Locate the **Domain Selection** section. From the **Selection** list, choose **Billet**.

SOLID MECHANICS (SOLID)

- 1 In the **Model Builder** window, under **Component 1 (comp1)** click **Solid Mechanics (solid)**.
- 2 In the **Settings** window for **Solid Mechanics**, locate the **Domain Selection** section.
- 3 Click  **Clear Selection**.
- 4 Select Domains 1 and 2 only.

Now, define the material for each domain.

ADD MATERIAL

- 1 In the **Materials** toolbar, click  **Add Material** to open the **Add Material** window.
- 2 Go to the **Add Material** window.
- 3 In the tree, select **Built-in > Structural steel**.
- 4 Click the **Add to Component** button in the window toolbar.
- 5 In the **Materials** toolbar, click  **Add Material** to close the **Add Material** window.

MATERIALS

Structural steel (mat1)

- 1 Select Domains 1 and 2 only.
- 2 In the **Settings** window for **Material**, locate the **Material Contents** section.

3 In the table, enter the following settings:

Property	Variable	Value	Unit	Property group
Heat capacity at constant pressure	Cp	$4.63 [N / (mm^2 \cdot K)] / \rho$	J/(kg·K)	Basic
Thermal conductivity	k_iso ; kii = k_iso, kij = 0	$24.33 [N / (s \cdot K)]$	W/(m·K)	Basic
Poisson's ratio	nu	0.3	l	Young's modulus and Poisson's ratio

The heat capacity is not used since it does not enter in the stationary heat transfer equation for solids without translational movement. The heat capacity is only provided for completeness in case you want to extend the model to perform transient simulations.

Billet

- 1 In the **Materials** toolbar, click  **Blank Material**.
- 2 In the **Settings** window for **Material**, type **Billet** in the **Label** text field.
- 3 Locate the **Geometric Entity Selection** section. From the **Selection** list, choose **Billet**.
- 4 Locate the **Material Contents** section. In the table, enter the following settings:

Property	Variable	Value	Unit	Property group
Heat capacity at constant pressure	Cp	$2.94 [N / (mm^2 \cdot K)] / \rho$	J/(kg·K)	Basic
Thermal conductivity	k_iso ; kii = k_iso, kij = 0	$210 [W / (m \cdot K)]$	W/(m·K)	Basic
Dynamic viscosity	mu	mu_a1	Pa·s	Basic
Density	rho	$2700 [kg / m^3]$	kg/m ³	Basic



Structural steel I (mat3)

- 1 In the **Model Builder** window, under **Component 1 (comp1) > Materials** right-click **Structural steel (mat1)** and choose **Duplicate**.
- 2 In the **Settings** window for **Material**, locate the **Geometric Entity Selection** section.
- 3 From the **Geometric entity level** list, choose **Boundary**.
- 4 From the **Selection** list, choose **Interior**.

Now, define the volume reference temperature in the solid domains. This temperature is used by materials to define the density in solids for both the **Heat Transfer in Solids and Fluids** and **Solid Mechanics** interfaces, and by the **Thermal Expansion** feature as the zero strain reference.

DEFINITIONS



Model Input 1

- 1 In the **Physics** toolbar, click  **Shared Properties** and choose **Model Input**.
- 2 Select Domain 1 only.
- 3 In the **Settings** window for **Model Input**, locate the **Definition** section.
- 4 Click  **Select Quantity**.
- 5 In the **Physical Quantity** dialog, type temperature in the text field.
- 6 In the tree, select **General > Volume reference temperature (K)**.
- 7 Click **OK**.
- 8 In the **Settings** window for **Model Input**, locate the **Definition** section.
- 9 In the text field, type `T_container`.

This value overrides the value defined under **Default Model Inputs** for the selected domain.

SHARED PROPERTIES

Model Input 2

- 1 In the **Physics** toolbar, click  **Shared Properties** and choose **Model Input**.
- 2 Select Domain 2 only.
- 3 In the **Settings** window for **Model Input**, locate the **Definition** section.
- 4 Click  **Select Quantity**.
- 5 In the **Physical Quantity** dialog, select **General > Volume reference temperature (K)** in the tree.
- 6 Click **OK**.
- 7 In the **Settings** window for **Model Input**, locate the **Definition** section.
- 8 In the text field, type `T_pd1`.

With the materials defined, you can set up the remaining physics of the model.

LAMINAR FLOW (SPF)

In the current model, the high viscosity of the fluid flow implies that the model is diffusion dominated. Pseudo time-stepping is thus not adapted to this case as it is based on the scale of the convective flux.

- 1 Click the  **Show More Options** button in the **Model Builder** toolbar.
- 2 In the **Show More Options** dialog, in the tree, select the checkbox for the node **Physics > Advanced Physics Options**.
- 3 Click **OK**.
- 4 In the **Model Builder** window, under **Component 1 (comp1)** click **Laminar Flow (spf)**.
- 5 In the **Settings** window for **Laminar Flow**, click to expand the **Advanced Settings** section.
- 6 Find the **Pseudo time stepping** subsection. From the **Use pseudo time stepping for stationary equation form** list, choose **Off**.

Initial Values 1

- 1 In the **Model Builder** window, under **Component 1 (comp1) > Laminar Flow (spf)** click **Initial Values 1**.
- 2 In the **Settings** window for **Initial Values**, locate the **Initial Values** section.
- 3 In the p text field, type P_{init} .

Symmetry 1

- 1 In the **Physics** toolbar, click  **Boundaries** and choose **Symmetry**.
- 2 Select Boundaries 9 and 114 only.

Inlet 1

- 1 In the **Physics** toolbar, click  **Boundaries** and choose **Inlet**.
- 2 Select Boundary 10 only.
- 3 In the **Settings** window for **Inlet**, locate the **Velocity** section.
- 4 Click the **Velocity field** button.
- 5 Specify the \mathbf{u}_0 vector as

0	x
0	y
V_ram	z

Wall 2

- 1 In the **Physics** toolbar, click  **Boundaries** and choose **Wall**.

- 2 In the **Settings** window for **Wall**, locate the **Boundary Selection** section.
- 3 From the **Selection** list, choose **Outside**.
- 4 Locate the **Boundary Condition** section. From the **Wall condition** list, choose **Slip**.

Outlet 1

- 1 In the **Physics** toolbar, click  **Boundaries** and choose **Outlet**.
- 2 Select Boundary 40 only.
- 3 In the **Settings** window for **Outlet**, locate the **Pressure Conditions** section.
- 4 In the p_0 text field, type P_{init} .

HEAT TRANSFER IN SOLIDS AND FLUIDS (HT)

Initial Values 1

- 1 In the **Model Builder** window, under **Component 1 (comp1)** > **Heat Transfer in Solids and Fluids (ht)** click **Initial Values 1**.
- 2 In the **Settings** window for **Initial Values**, locate the **Initial Values** section.
- 3 In the T text field, type $T_{container}$.

Temperature 1

- 1 In the **Physics** toolbar, click  **Boundaries** and choose **Temperature**.
- 2 Select Boundaries 2, 5, and 7 only.
- 3 In the **Settings** window for **Temperature**, locate the **Temperature** section.
- 4 In the T_0 text field, type $T_{container}$.

Heat Flux 1

- 1 In the **Physics** toolbar, click  **Boundaries** and choose **Heat Flux**.
- 2 Select Boundary 10 only.
- 3 In the **Settings** window for **Heat Flux**, locate the **Heat Flux** section.
- 4 From the **Flux type** list, choose **Convective heat flux**.
- 5 In the h text field, type $Heat_{alfe}$.
- 6 In the T_{ext} text field, type T_{ram} .

Heat Flux 2

- 1 In the **Physics** toolbar, click  **Boundaries** and choose **Heat Flux**.
- 2 In the **Settings** window for **Heat Flux**, locate the **Boundary Selection** section.
- 3 From the **Selection** list, choose **Outside**.
- 4 Locate the **Heat Flux** section. From the **Flux type** list, choose **Convective heat flux**.

- 5 In the h text field, type H_conv.
- 6 In the T_{ext} text field, type T_air.

Outflow 1

- 1 In the **Physics** toolbar, click  **Boundaries** and choose **Outflow**.
- 2 Select Boundary 40 only.

Thin Layer 1

- 1 In the **Physics** toolbar, click  **Boundaries** and choose **Thin Layer**.
- 2 In the **Settings** window for **Thin Layer**, locate the **Boundary Selection** section.
- 3 From the **Selection** list, choose **Interior**.
- 4 Locate the **Layer Model** section. From the **Specify** list, choose **Thermal resistance**.
- 5 Locate the **Heat Conduction** section. In the R_s text field, type 1/Heat_alfe.

MATERIALS

Structural steel 1 (mat3)

- 1 In the **Model Builder** window, under **Component 1 (comp1) > Materials** click **Structural steel 1 (mat3)**.
- 2 In the **Settings** window for **Material**, locate the **Material Contents** section.
- 3 In the table, enter the following settings:

Property	Variable	Value	Unit	Property group
Thickness	lth	D_alfe	m	Shell

SOLID MECHANICS (SOLID)

For faster convergence use linear elements. You can always improve the solution using the default quadratic elements.

- 1 In the **Model Builder** window, under **Component 1 (comp1)** click **Solid Mechanics (solid)**.
- 2 In the **Settings** window for **Solid Mechanics**, click to expand the **Discretization** section.
- 3 From the **Displacement field** list, choose **Linear**.

Linear Elastic Material 1

Both Young's modulus and Poisson's ratio are temperature dependent. Follow these steps to verify that the temperature is defined by the **Heat Transfer in Solids and Fluids** interface.

- 1 In the **Model Builder** window, under **Component 1 (comp1) > Solid Mechanics (solid)** click **Linear Elastic Material 1**.

- 2 In the **Settings** window for **Linear Elastic Material**, locate the **Model Input** section.
- 3 Click  **Go to Source** for **Temperature** for the **Temperature (T)**.

GLOBAL DEFINITIONS

Default Model Inputs

Locate the **Browse Model Inputs** section. The icon column of the table under **Model input contributions** shows that it is the **Heat Transfer in Solids and Fluids** interface that defines the temperature in the solid and fluid domains and on the thin-layer boundaries.

SOLID MECHANICS (SOLID)

Roller I

- 1 In the **Physics** toolbar, click  **Boundaries** and choose **Roller**.
- 2 Select Boundaries 2, 5, and 7 only.

Symmetry I

- 1 In the **Physics** toolbar, click  **Boundaries** and choose **Symmetry**.
- 2 Select Boundaries 1, 4, 112, and 113 only.

MULTIPHYSICS

Fluid–Structure Interaction I (fsi)

- 1 In the **Physics** toolbar, click  **Multiphysics Couplings** and choose **Boundary > Fluid–Structure Interaction**.
- 2 In the **Settings** window for **Fluid–Structure Interaction**, locate the **Boundary Selection** section.
- 3 From the **Selection** list, choose **All boundaries**.

Thermal Expansion I (tel)

- 1 In the **Physics** toolbar, click  **Multiphysics Couplings** and choose **Domain > Thermal Expansion**.
- 2 Select Domains 1 and 2 only.

MESH I

Free Triangular I

- 1 In the **Mesh** toolbar, click  **More Generators** and choose **Free Triangular**.
- 2 Select Boundary 40 only.

Size 1

- 1 Right-click **Free Triangular 1** and choose **Size**.
- 2 In the **Settings** window for **Size**, locate the **Element Size** section.
- 3 Click the **Custom** button.
- 4 Locate the **Element Size Parameters** section.
- 5 Select the **Maximum element size** checkbox. In the associated text field, type 0.0014.
- 6 Select the **Curvature factor** checkbox. In the associated text field, type 0.2.
- 7 Click  **Build Selected**.

Swept 1

- 1 In the **Mesh** toolbar, click  **Swept**.
- 2 In the **Settings** window for **Swept**, locate the **Domain Selection** section.
- 3 From the **Geometric entity level** list, choose **Domain**.
- 4 Select Domain 4 only.

Distribution 1

- 1 Right-click **Swept 1** and choose **Distribution**.
- 2 In the **Settings** window for **Distribution**, locate the **Distribution** section.
- 3 In the **Number of elements** text field, type 24.
- 4 Click  **Build All**.

Free Tetrahedral 1

In the **Mesh** toolbar, click  **Free Tetrahedral**.

Size 1

- 1 Right-click **Free Tetrahedral 1** and choose **Size**.
- 2 In the **Settings** window for **Size**, locate the **Element Size** section.
- 3 Click the **Custom** button.
- 4 Locate the **Element Size Parameters** section.
- 5 Select the **Maximum element size** checkbox. In the associated text field, type 0.0085.

Size 2

- 1 In the **Model Builder** window, right-click **Free Tetrahedral 1** and choose **Size**.
- 2 In the **Settings** window for **Size**, locate the **Geometric Entity Selection** section.
- 3 From the **Geometric entity level** list, choose **Boundary**.
- 4 Select Boundaries 12 and 13 only.

- 5 Locate the **Element Size** section. Click the **Custom** button.
- 6 Locate the **Element Size Parameters** section.
- 7 Select the **Maximum element size** checkbox. In the associated text field, type 0.002.

Size 3

- 1 Right-click **Free Tetrahedral I** and choose **Size**.
- 2 In the **Settings** window for **Size**, locate the **Geometric Entity Selection** section.
- 3 From the **Geometric entity level** list, choose **Domain**.
- 4 Select Domain 3 only.
- 5 Locate the **Element Size** section. Click the **Custom** button.
- 6 Locate the **Element Size Parameters** section.
- 7 Select the **Minimum element size** checkbox. In the associated text field, type $5e-4$.

Size

- 1 In the **Model Builder** window, under **Component 1 (comp1) > Mesh 1** click **Size**.
- 2 In the **Settings** window for **Size**, locate the **Element Size** section.
- 3 From the **Predefined** list, choose **Finer**.

4 Click  **Build All**.

You should now see the following meshed geometry.

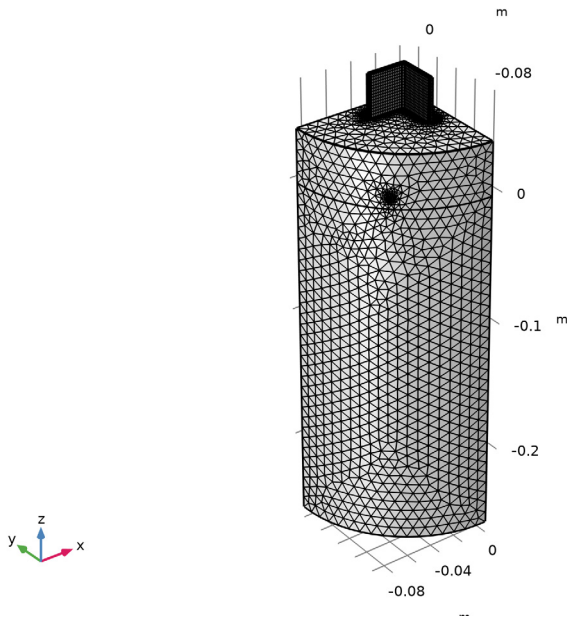

STUDY 1

Step 1: Stationary

Use two stationary study steps. Solve first for the fluid dynamics and heat transfer to determine the thermal load and the pressure load and then for the structural mechanics.

- 1 In the **Model Builder** window, under **Study 1** click **Step 1: Stationary**.
- 2 In the **Settings** window for **Stationary**, locate the **Physics and Variables Selection** section.
- 3 In the **Solve for** column of the table, under **Component 1 (comp1)**, clear the checkbox for **Solid Mechanics (solid)**.
- 4 In the **Solve for** column of the table, under **Component 1 (comp1) > Multiphysics**, clear the checkboxes for **Fluid-Structure Interaction 1 (fsi1)** and **Thermal Expansion 1 (te1)**.



Step 2: Stationary 2

- 1 In the **Study** toolbar, click  **Stationary**.
- 2 In the **Settings** window for **Stationary**, locate the **Physics and Variables Selection** section.

- 3 In the **Solve for** column of the table, under **Component 1 (comp1)**, clear the checkboxes for **Heat Transfer in Solids and Fluids (ht)** and **Laminar Flow (spf)**.
- 4 In the **Solve for** column of the table, under **Component 1 (comp1) > Multiphysics**, clear the checkbox for **Nonisothermal Flow 1 (nitf1)**.



For the structural analysis, use a memory efficient iterative solver to make it possible to solve the problem also on computers with limited memory.

Solution 1 (sol1)

- 1 In the **Study** toolbar, click  **Show Default Solver**.
- 2 In the **Model Builder** window, expand the **Solution 1 (sol1)** node.
- 3 In the **Model Builder** window, expand the **Study 1 > Solver Configurations > Solution 1 (sol1) > Stationary Solver 2** node.
- 4 Right-click **Study 1 > Solver Configurations > Solution 1 (sol1) > Stationary Solver 2** and choose **Iterative**.
- 5 In the **Study** toolbar, click  **Compute**.

RESULTS

Transparency 1

- 1 In the **Model Builder** window, expand the **Results > Temperature (ht)** node.
- 2 Right-click **Domain** and choose **Transparency**.
- 3 In the **Settings** window for **Transparency**, locate the **Transparency** section.
- 4 Find the **Transparency** subsection. In the **Transparency** text field, type 0.75.
The first default plot shows the temperature (Figure 3).
- 5 In the **Temperature (ht)** toolbar, click  **Plot**.
- 6 Click the  **Zoom Extents** button in the **Graphics** toolbar.

Modify the second default plot to see the velocity field and streamlines at the profile section (Figure 4).

Study 1/Solution Store 1 (sol2)

In the **Model Builder** window, expand the **Results > Datasets** node, then click **Study 1/Solution Store 1 (sol2)**.

Selection

- 1 In the **Results** toolbar, click  **Attributes** and choose **Selection**.
- 2 In the **Settings** window for **Selection**, locate the **Geometric Entity Selection** section.

3 From the **Geometric entity level** list, choose **Domain**.

4 From the **Selection** list, choose **Billet**.

Velocity (spf)

1 In the **Model Builder** window, under **Results** click **Velocity (spf)**.

2 In the **Settings** window for **3D Plot Group**, locate the **Data** section.

3 From the **Dataset** list, choose **Study 1/Solution Store 1 (sol2)**.

Multislice 1

1 In the **Model Builder** window, expand the **Velocity (spf)** node, then click **Multislice 1**.

2 In the **Settings** window for **Multislice**, locate the **Multiplane Data** section.

3 Find the **x-planes** subsection. In the **Planes** text field, type 0.

4 Find the **y-planes** subsection. In the **Planes** text field, type 0.

5 Find the **z-planes** subsection. From the **Entry method** list, choose **Coordinates**.

6 In the **Coordinates** text field, type 0.0151.

7 In the **Velocity (spf)** toolbar, click  **Plot**.

Velocity (spf)

In the **Model Builder** window, click **Velocity (spf)**.

Streamline 1

1 In the **Velocity (spf)** toolbar, click  **Streamline**.

2 In the **Settings** window for **Streamline**, click **Replace Expression** in the upper-right corner of the **Expression** section. From the menu, choose **Component 1 (comp1) > Laminar Flow > Velocity and pressure > u,v,w - Velocity field (spatial frame)**.

3 Locate the **Streamline Positioning** section. From the **Positioning** list, choose **Magnitude controlled**.

4 In the **Minimum density level** text field, type 6.7.

5 In the **Maximum density level** text field, type 13.4.

6 Locate the **Coloring and Style** section. Find the **Line style** subsection. From the **Type** list, choose **Ribbon**.

7 In the **Width expression** text field, type 0.001.

8 Select the **Width scale factor** checkbox.

9 Find the **Point style** subsection. From the **Type** list, choose **Arrow**.

10 Select the **Number of arrows** checkbox. In the associated text field, type 70.

11 Click to expand the **Inherit Style** section.

Color Expression 1



- 1 In the **Velocity (spf)** toolbar, click  **Color Expression**.
- 2 In the **Settings** window for **Color Expression**, click **Replace Expression** in the upper-right corner of the **Expression** section. From the menu, choose **Component 1 (comp1) > Laminar Flow > Velocity and pressure > spf.U - Velocity magnitude - m/s**.

Streamline 1

- 1 In the **Model Builder** window, click **Streamline 1**.
- 2 In the **Settings** window for **Streamline**, locate the **Inherit Style** section.
- 3 From the **Plot** list, choose **Multislice 1**.
- 4 In the **Velocity (spf)** toolbar, click  **Plot**.

Velocity (spf)

To get a better view, rotate the geometry in the **Graphics** window. You can preserve a view for a plot by creating a **View** feature node as follows:

- 1 In the **Model Builder** window, click **Velocity (spf)**.
- 2 In the **Settings** window for **3D Plot Group**, locate the **Plot Settings** section.
- 3 From the **View** list, choose **New view**.
- 4 In the **Velocity (spf)** toolbar, click  **Plot**.
- 5 Click  **Go to Source**.

View 3D 3

- 1 In the **Model Builder** window, under **Results > Views** click **View 3D 3**.
- 2 Use the **Graphics** toolbox to get a satisfying view.
- 3 In the **Settings** window for **View 3D**, locate the **View** section.
- 4 Select the **Lock camera** checkbox.

Velocity (spf)

For a clearer visualization, you can duplicate this plot group and remove the geometry edges and the velocity slice, and add instead a temperature surface at the outside part.

Velocity and Outside Temperature

- 1 In the **Model Builder** window, right-click **Velocity (spf)** and choose **Duplicate**.
- 2 In the **Settings** window for **3D Plot Group**, type **Velocity and Outside Temperature** in the **Label** text field.
- 3 Right-click **Velocity and Outside Temperature** and choose **Move Up**.
- 4 Right-click **Velocity and Outside Temperature** and choose **Move Up**.

Multislice 1

- 1 In the **Model Builder** window, expand the **Velocity and Outside Temperature** node.
- 2 Right-click **Multislice 1** and choose **Delete**.
- 3 Click **Yes** to confirm.

Surface 1

- 1 In the **Results** toolbar, click  **More Datasets** and choose **Surface**.
- 2 Select Boundaries 55, 95, and 108 only.

Velocity and Outside Temperature

In the **Model Builder** window, under **Results** click **Velocity and Outside Temperature**.

Surface 1

- 1 In the **Velocity and Outside Temperature** toolbar, click  **Surface**.
- 2 In the **Settings** window for **Surface**, locate the **Data** section.
- 3 From the **Dataset** list, choose **Surface 1**.
- 4 Locate the **Coloring and Style** section. From the **Color table** list, choose **HeatCameraLight**.

Velocity and Outside Temperature

- 1 In the **Model Builder** window, click **Velocity and Outside Temperature**.
- 2 In the **Settings** window for **3D Plot Group**, locate the **Color Legend** section.
- 3 From the **Position** list, choose **Right double**.
- 4 Locate the **Plot Settings** section. Clear the **Plot dataset edges** checkbox.
- 5 In the **Velocity and Outside Temperature** toolbar, click  **Plot**.

Stress (solid)

The next plot shows the von Mises stress and deformation distribution in the container. To reproduce the [Figure 5](#), apply the **View 3D 3**.

- 1 In the **Model Builder** window, click **Stress (solid)**.
- 2 In the **Settings** window for **3D Plot Group**, locate the **Plot Settings** section.
- 3 From the **View** list, choose **View 3D 3**.

Volume 1

- 1 In the **Model Builder** window, expand the **Stress (solid)** node, then click **Volume 1**.
- 2 In the **Settings** window for **Volume**, locate the **Expression** section.
- 3 From the **Unit** list, choose **GPa**.
- 4 In the **Stress (solid)** toolbar, click  **Plot**.

Geometry Modeling Instructions

Follow these steps to create the geometry for the aluminum extrusion model. Note that a license for the CAD Import Module or the Design Module is required for some geometric operations.

From the **File** menu, choose **New**.

NEW

In the **New** window, click  **Model Wizard**.

MODEL WIZARD

- 1 In the **Model Wizard** window, click  **3D**.
- 2 Click **Done**.

GEOMETRY I

- 1 In the **Model Builder** window, under **Component 1 (comp1)** click **Geometry 1**.
- 2 In the **Settings** window for **Geometry**, locate the **Advanced** section.
- 3 From the **Geometry representation** list, choose **CAD kernel**.
- 4 Select the **Design Module Boolean operations** checkbox.
- 5 Click the  **Wireframe Rendering** button in the **Graphics** toolbar.

Cylinder 1 (cyl1)

- 1 In the **Geometry** toolbar, click  **Cylinder**.
- 2 In the **Settings** window for **Cylinder**, locate the **Size and Shape** section.
- 3 In the **Radius** text field, type 90 [mm].
- 4 In the **Height** text field, type 297 [mm].
- 5 Locate the **Position** section. In the **z** text field, type -257 [mm].
- 6 Click to expand the **Layers** section. In the table, enter the following settings:

Layer name	Thickness (m)
Layer 1	40 [mm]

- 7 Clear the **Layers on side** checkbox.
- 8 Select the **Layers on top** checkbox.

Cylinder 2 (cyl2)

- 1 In the **Geometry** toolbar, click  **Cylinder**.

- 2 In the **Settings** window for **Cylinder**, locate the **Size and Shape** section.
- 3 In the **Radius** text field, type 73 [mm].
- 4 In the **Height** text field, type 257 [mm].
- 5 Locate the **Position** section. In the **z** text field, type -257 [mm].

Union 1 (uni1)

- 1 In the **Geometry** toolbar, click  **Booleans and Partitions** and choose **Union**.
- 2 Click in the **Graphics** window and then press Ctrl+A to select both objects.

Block 1 (blk1)

- 1 In the **Geometry** toolbar, click  **Block**.
- 2 In the **Settings** window for **Block**, locate the **Size and Shape** section.
- 3 In the **Width** text field, type 90 [mm].
- 4 In the **Depth** text field, type 90 [mm].
- 5 In the **Height** text field, type 297 [mm].
- 6 Locate the **Position** section. In the **x** text field, type -90 [mm].
- 7 In the **y** text field, type -90 [mm].
- 8 In the **z** text field, type -257 [mm].

Intersection 1 (int1)

- 1 In the **Geometry** toolbar, click  **Booleans and Partitions** and choose **Intersection**.
- 2 Click in the **Graphics** window and then press Ctrl+A to select both objects.

Cone 1 (cone1)

- 1 In the **Geometry** toolbar, click  **Cone**.
- 2 In the **Settings** window for **Cone**, locate the **Size and Shape** section.
- 3 In the **Bottom radius** text field, type 8.25 [mm].
- 4 In the **Height** text field, type 15 [mm].
- 5 In the **Top radius** text field, type 2.25 [mm].
- 6 Locate the **Position** section. In the **x** text field, type -42.59 [mm].
- 7 In the **y** text field, type -13.25 [mm].

Cone 2 (cone2)

- 1 Right-click **Cone 1 (cone1)** and choose **Duplicate**.
- 2 In the **Settings** window for **Cone**, locate the **Position** section.
- 3 In the **x** text field, type -13.25 [mm].

Work Plane 1 (wp1)

- 1 In the **Geometry** toolbar, click  **Work Plane**.
- 2 In the **Settings** window for **Work Plane**, locate the **Plane Definition** section.
- 3 From the **Plane** list, choose **yz-plane**.
- 4 From the **Offset type** list, choose **Through vertex**.
- 5 On the object **cone1**, select Point 5 only.

Work Plane 1 (wp1) > Plane Geometry

In the **Model Builder** window, click **Plane Geometry**.

Work Plane 1 (wp1) > Cross Section 1 (cro1)

- 1 In the **Work Plane** toolbar, click  **Cross Section**.
- 2 In the **Settings** window for **Cross Section**, locate the **Cross Section** section.
- 3 From the **Intersect** list, choose **Selected objects**.
- 4 Select the object **cone1** only.

Extrude 1 (ext1)



- 1 In the **Model Builder** window, under **Component 1 (comp1) > Geometry 1** right-click **Work Plane 1 (wp1)** and choose **Extrude**.
- 2 In the **Settings** window for **Extrude**, locate the **Distances** section.
- 3 From the **Specify** list, choose **Vertices to extrude to**.
- 4 On the object **cone2**, select Point 5 only.

Rotate 1 (rot1)

- 1 In the **Geometry** toolbar, click  **Transforms** and choose **Rotate**.
- 2 Select the objects **cone1** and **ext1** only.
- 3 In the **Settings** window for **Rotate**, locate the **Input** section.
- 4 Select the **Keep input objects** checkbox.
- 5 Locate the **Rotation** section. In the **Angle** text field, type 90[deg].
- 6 Locate the **Point on Axis of Rotation** section. In the **x** text field, type -13.25[mm].
- 7 In the **y** text field, type -13.25[mm].

Union 2 (uni2)

- 1 In the **Geometry** toolbar, click  **Booleans and Partitions** and choose **Union**.
- 2 Select the objects **cone1**, **cone2**, **ext1**, **rot1(1)**, and **rot1(2)** only.
- 3 In the **Settings** window for **Union**, locate the **Union** section.

- 4 Clear the **Keep interior boundaries** checkbox.
- 5 In the **Geometry** toolbar, click  **Defeaturing and Repair** and choose **Replace Faces**.
- 6 In the **Tools** window for **Replace Faces**, in the **Graphics** window toolbar, click  next to **Select Boundaries**, then choose **Group by Continuous Tangent**.
- 7 On the object **uni2**, select Boundaries 3, 4, 6–9, 12, 14–24, and 26–29 only.
- 8 Locate the **Replace Faces** section. From the **Heal method** list, choose **Create capping faces**.
- 9 Click **Replace Selected**.

Fillet 1 (fil1)

- 1 In the **Geometry** toolbar, click  **Editing** and choose **Fillet**.
- 2 In the **Settings** window for **Fillet**, locate the **Type of Fillet** section.
- 3 From the **Type** list, choose **Variable radius**.
- 4 On the object **rfa1**, select Edge 15 only.
- 5 Locate the **Radii** section. In the table, enter the following settings:

Edge	Parameter	Radius	Clamp
15	0	2 [mm]	
15	1	1 [mm]	

Fillet 2 (fil2)

- 1 In the **Geometry** toolbar, click  **Editing** and choose **Fillet**.
- 2 In the **Settings** window for **Fillet**, locate the **Edges** section.
- 3 Select the **Group by continuous tangent** checkbox.
- 4 On the object **fill**, select Edges 4, 5, 8, 10, 18–20, 23, 25, and 27 only.
- 5 Locate the **Radius** section. In the **Radius** text field, type 1 [mm].

Work Plane 2 (wp2)

- 1 In the **Geometry** toolbar, click  **Work Plane**.
- 2 In the **Settings** window for **Work Plane**, locate the **Plane Definition** section.
- 3 In the **z-coordinate** text field, type 15 [mm].

Work Plane 2 (wp2) > Plane Geometry

In the **Model Builder** window, click **Plane Geometry**.

Work Plane 2 (wp2) > Rectangle 1 (r1)



- 1 In the **Work Plane** toolbar, click  **Rectangle**.
- 2 In the **Settings** window for **Rectangle**, locate the **Size and Shape** section.

- 3 In the **Width** text field, type 30.6[mm].
- 4 In the **Height** text field, type 30.6[mm].
- 5 Locate the **Position** section. In the **xw** text field, type -42.35[mm].
- 6 In the **yw** text field, type -42.35[mm].

Work Plane 2 (wp2) > Rectangle 2 (r2)

- 1 Right-click **Component 1 (comp1) > Geometry 1 > Work Plane 2 (wp2) > Plane Geometry > Rectangle 1 (r1)** and choose **Duplicate**.
- 2 In the **Settings** window for **Rectangle**, locate the **Size and Shape** section.
- 3 In the **Width** text field, type 27.6[mm].
- 4 In the **Height** text field, type 27.6[mm].

Work Plane 2 (wp2) > Difference 1 (dif1)

- 1 In the **Work Plane** toolbar, click  **Booleans and Partitions** and choose **Difference**.
- 2 Select the object **r1** only.
- 3 In the **Settings** window for **Difference**, locate the **Difference** section.
- 4 Click to select the  **Activate Selection** toggle button for **Objects to subtract**.
- 5 Select the object **r2** only.

Work Plane 2 (wp2) > Fillet 1 (fil1)

- 1 In the **Work Plane** toolbar, click  **Fillet**.
- 2 On the object **dif1**, select Points 1–3 and 5 only.
- 3 In the **Settings** window for **Fillet**, locate the **Radius** section.
- 4 In the **Radius** text field, type 0.5[mm].

Work Plane 2 (wp2) > Fillet 2 (fil2)

- 1 In the **Work Plane** toolbar, click  **Fillet**.
- 2 On the object **fil1**, select Point 10 only.
- 3 In the **Settings** window for **Fillet**, locate the **Radius** section.
- 4 In the **Radius** text field, type 1[mm].

Work Plane 2 (wp2) > Fillet 3 (fil3)

- 1 In the **Work Plane** toolbar, click  **Fillet**.
- 2 On the object **fil2**, select Point 6 only.
- 3 In the **Settings** window for **Fillet**, locate the **Radius** section.
- 4 In the **Radius** text field, type 2[mm].

Extrude 2 (ext2)

- 1 In the **Model Builder** window, under **Component 1 (comp1)** > **Geometry 1** right-click **Work Plane 2 (wp2)** and choose **Extrude**.
- 2 In the **Settings** window for **Extrude**, locate the **Distances** section.
- 3 In the table, enter the following settings:

Distances (m)
55 [mm]
5 [mm]

Work Plane 3 (wp3)

- 1 In the **Geometry** toolbar, click  **Work Plane**.
- 2 In the **Settings** window for **Work Plane**, locate the **Plane Definition** section.
- 3 From the **Plane type** list, choose **Face parallel**.
- 4 On the object **ext2**, select Boundary 6 only.

Work Plane 3 (wp3) > Plane Geometry

In the **Model Builder** window, click **Plane Geometry**.

Work Plane 3 (wp3) > Cross Section 1 (cro1)

- 1 In the **Work Plane** toolbar, click  **Cross Section**.
- 2 In the **Settings** window for **Cross Section**, locate the **Cross Section** section.
- 3 From the **Intersect** list, choose **Selected objects**.
- 4 Select the object **ext2** only.

Work Plane 3 (wp3) > Offset 1 (off1)

- 1 In the **Work Plane** toolbar, click  **Offset**.
- 2 Select the object **cro1** only.
- 3 In the **Settings** window for **Offset**, locate the **Options** section.
- 4 In the **Distance** text field, type 1.2 [mm].
- 5 Locate the **Input** section. Clear the **Keep input objects** checkbox.

Work Plane 4 (wp4)

- 1 In the **Model Builder** window, under **Component 1 (comp1)** > **Geometry 1** right-click **Work Plane 3 (wp3)** and choose **Duplicate**.
- 2 In the **Settings** window for **Work Plane**, locate the **Plane Definition** section.
- 3 Click to select the  **Activate Selection** toggle button for **Planar face**.

- 4 In the tree, select **ext2**.
- 5 On the object **int1**, select Boundary 7 only.
- 6 In the **Model Builder** window, expand the **Work Plane 4 (wp4)** node.

Work Plane 4 (wp4) > Offset 1 (off1)

- 1 In the **Model Builder** window, expand the **Component 1 (comp1) > Geometry 1 > Work Plane 4 (wp4) > Plane Geometry** node, then click **Offset 1 (off1)**.
- 2 In the **Settings** window for **Offset**, locate the **Options** section.
- 3 In the **Distance** text field, type 2.25[mm].

Work Plane 4 (wp4)

- 1 In the **Model Builder** window, under **Component 1 (comp1) > Geometry 1** click **Work Plane 4 (wp4)**.
- 2 In the **Settings** window for **Work Plane**, click  **Build Selected**.

Loft 1 (loft1)

- 1 In the **Geometry** toolbar, click  **Loft**.
- 2 Select the objects **wp3** and **wp4** only.
- 3 In the **Settings** window for **Loft**, locate the **General** section.
- 4 From the **Face partitioning** list, choose **Columns**.

Extract 1 (extract1)

- 1 In the **Geometry** toolbar, click  **Extract**.
- 2 In the **Settings** window for **Extract**, locate the **Entities or Objects to Extract** section.
- 3 From the **Geometric entity level** list, choose **Domain**.
- 4 On the object **ext2**, select Domain 1 only.

Union 3 (uni3)

- 1 In the **Geometry** toolbar, click  **Booleans and Partitions** and choose **Union**.
- 2 Select the objects **extract1** and **loft1** only.
- 3 In the **Settings** window for **Union**, locate the **Union** section.
- 4 Clear the **Keep interior boundaries** checkbox.

Difference 1 (dif1)

- 1 In the **Geometry** toolbar, click  **Booleans and Partitions** and choose **Difference**.
- 2 Select the object **int1** only.
- 3 In the **Settings** window for **Difference**, locate the **Difference** section.

- 4 Click to select the  **Activate Selection** toggle button for **Objects to subtract**.
- 5 Select the object **uni3** only.

Fillet 3 (fil3)

- 1 In the **Geometry** toolbar, click  **Editing** and choose **Fillet**.
- 2 In the **Settings** window for **Fillet**, locate the **Edges** section.
- 3 Select the **Group by continuous tangent** checkbox.
- 4 On the object **dif1**, select Edges 25, 26, 29, 35, 38, 50, 56, 57, 64, 67, 76, and 79 only.
- 5 Locate the **Radius** section. In the **Radius** text field, type 0.5[mm].

Fillet 4 (fil4)

- 1 In the **Geometry** toolbar, click  **Editing** and choose **Fillet**.
- 2 In the **Settings** window for **Fillet**, locate the **Edges** section.
- 3 Select the **Group by continuous tangent** checkbox.
- 4 On the object **fil3**, select Edges 14, 16, 18, 36, 50, 51, 53, 75, 89, 91, and 108 only.
- 5 Locate the **Radius** section. In the **Radius** text field, type 1[mm].

Extract 2 (extract2)

- 1 In the **Geometry** toolbar, click  **Extract**.
- 2 In the **Settings** window for **Extract**, locate the **Entities or Objects to Extract** section.
- 3 From the **Geometric entity level** list, choose **Domain**.
- 4 On the object **ext2**, select Domain 1 only.
- 5 On the object **fil4**, select Domain 3 only.
- 6 From the **Input object handling** list, choose **Create remainder object**.

Union 4 (uni4)

- 1 In the **Geometry** toolbar, click  **Booleans and Partitions** and choose **Union**.
- 2 Select the objects **extract2(1)**, **extract2(3)**, and **fil2** only.
- 3 In the **Settings** window for **Union**, locate the **Union** section.
- 4 Clear the **Keep interior boundaries** checkbox.

Cylinder 3 (cyl3)



- 1 In the **Geometry** toolbar, click  **Cylinder**.
- 2 In the **Settings** window for **Cylinder**, locate the **Size and Shape** section.
- 3 In the **Radius** text field, type 1.5[mm].
- 4 In the **Height** text field, type 64[mm].

- 5 Locate the **Position** section. In the **x** text field, type $-19.86[\text{mm}]$.
- 6 In the **y** text field, type $-19.86[\text{mm}]$.
- 7 In the **z** text field, type $20.44[\text{mm}]$.
- 8 Locate the **Axis** section. From the **Axis type** list, choose **Cartesian**.
- 9 In the **x** text field, type -1 .
- 10 In the **y** text field, type -1 .
- 11 In the **z** text field, type 0 .



Rotate 2 (rot2)

- 1 In the **Geometry** toolbar, click  **Transforms** and choose **Rotate**.
- 2 Select the object **cyl3** only.
- 3 In the **Settings** window for **Rotate**, locate the **Rotation** section.
- 4 From the **Axis type** list, choose **Cartesian**.
- 5 In the **x** text field, type -1 .
- 6 In the **y** text field, type 1 .
- 7 In the **z** text field, type 0 .
- 8 In the **Angle** text field, type $-12[\text{deg}]$.
- 9 Locate the **Point on Axis of Rotation** section. In the **x** text field, type $20.44[\text{mm}]$.
- 10 In the **z** text field, type $20.44[\text{mm}]$.
- 11 In the **x** text field, type $-19.86[\text{mm}]$.
- 12 In the **y** text field, type $-19.86[\text{mm}]$.

Difference 2 (dif2)

- 1 In the **Geometry** toolbar, click  **Booleans and Partitions** and choose **Difference**.
- 2 Select the object **extract2(4)** only.
- 3 In the **Settings** window for **Difference**, locate the **Difference** section.
- 4 Click to select the  **Activate Selection** toggle button for **Objects to subtract**.
- 5 Select the object **rot2** only.

Difference 3 (dif3)



- 1 In the **Geometry** toolbar, click  **Booleans and Partitions** and choose **Difference**.
- 2 Select the object **dif2** only.
- 3 In the **Settings** window for **Difference**, locate the **Difference** section.
- 4 Click to select the  **Activate Selection** toggle button for **Objects to subtract**.

- 5 Select the object **uni4** only.
- 6 Select the **Keep objects to subtract** checkbox.

Union 5 (uni5)

- 1 In the **Geometry** toolbar, click  **Booleans and Partitions** and choose **Union**.
- 2 Click in the **Graphics** window and then press Ctrl+A to select all objects.





Convert to COMSOL I (ccom1)

- 1 In the **Geometry** toolbar, click  **Conversions** and choose **Convert to COMSOL**.
- 2 Click the  **Select All** button in the **Graphics** toolbar.

Collapse Faces I (clf1)

- 1 In the **Geometry** toolbar, click  **Virtual Operations** and choose **Collapse Faces**.
- 2 On the object **fin**, select Boundary 92 only.

Ignore Edges I (ige1)

- 1 In the **Geometry** toolbar, click  **Virtual Operations** and choose **Ignore Edges**.
- 2 On the object **clf1**, select Edges 18 and 20 only.
- 3 In the **Settings** window for **Ignore Edges**, click  **Build Selected**.
- 4 In the **Geometry** toolbar, click  **Export**.
- 5 In the **Export[noun]** window for **Geometry**, locate the **Export** section.
- 6 In the **Filename** text field, type aluminum_extrusion_fsi.mphbin.
- 7 In the **Model Builder** window, click **Ignore Edges I (ige1)**.
- 8 Click  **Export**.