



Model created in COMSOL Multiphysics 6.4

Screw Conveyor

Introduction

A screw conveyor is a mechanical device that is commonly used to move bulk granular materials. They can be used to transport the materials either horizontally or over an incline, which also allows for elevating the material. Additional specialized tasks such as heating, cooling, drying and mixing can also be incorporated along with the transport process. Screw conveyors are widely used across various industries including food processing, pharmaceuticals, chemical industries, agriculture, cosmetics, and plastics.

A screw conveyor typically consists of a U-shaped trough or a tube with a rotating central shaft along its length. The central shaft contains helical screw that is rotated about its axis. The amount of material transported and its speed is affected by several factors including the material and contact properties of the grains and the walls, filling level of the trough, and rotational speed. The mass-flow rate is often proportional to the rotational speed.

This example uses the Granular Flow interface to model the transport of grains using a screw conveyor operated at a constant rotational speed. This model also shows the use of a Bounding Box feature to avoid scenarios that may adversely affect the performance of the Granular Flow interface. The mass-flow rate through the conveyor is evaluated using a Model Method.

Model Definition

The geometry consists of a cylindrical tube with a casing radius of 20.4 cm and a length of 1.3 m. A central shaft of radius 10 cm runs through the length of the tube. The central shaft has helical screw blades attached to it with a pitch of 20 cm and a gap of 4 mm between the blade and the tube. The overall length of the shaft is such that there are six turns of the helix. The tube and the screw are rotated to have an inclination of 10 degrees. The grains enter the tube via conical hopper and exit via a circular outlet at the other end of the tube. The geometry is presented in [Figure 1](#).

The grains have a density of 4200 kg/m^3 and a diameter of 10 mm. The grains are released in ten batches of 2500 grains each with an interval of 0.5 s. The screw is rotated at a constant angular speed of 120 rpm. The transport of the grains is simulated for a total of 20 s. The mass-flow rate through the screw conveyor is measured by evaluating the overall mass of the grains that pass through an imaginary plane in the middle of the tube.

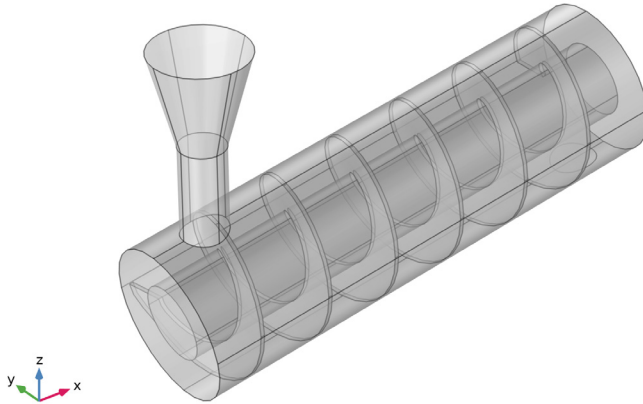

Figure 1: Model geometry.

Notes About the COMSOL Implementation

The model is solved using a single **Time Dependent** study step. The grains are released into the conical hopper using the **Release** feature. The rotation of the screw is controlled by the **Wall Movement** settings in the **Wall** feature. The grains can pass through the interior boundaries and out of the tube using an **Outlet** feature. The grains exiting the tube can continue moving away from the trough, which can adversely affect the performance of the Granular Flow interface.

The maximum allowed time step taken by the **Time-Dependent Solver** in Granular Flow is often limited by the collision time scales of the grain-grain and grain-wall interactions. The collision time scales are often strongly dependent on the material properties such as density and Young's modulus with stiffer grains generally exhibiting smaller collision times, thus requiring even smaller time steps. In many instances however, the stiffness of the grains and walls have a very limited effect on the bulk behavior of granular materials, and the materials can thus be made artificially less stiff in order to speed up the simulations.

A **Bounding Box** feature is used to remove such grains from the simulation. An user-defined variable is added to each grain to keep track of the grains that pass through an imaginary

plane. The mass-flow rate can then be obtained by counting the overall mass of the grains that pass through the plane in a given time window divided by the length of the time window. This averaging of the time series data is achieved by adding and running a Model Method.

Note: Model methods can only be set up in the COMSOL Desktop environment on the Windows version of COMSOL Multiphysics.

Results and Discussion

A snapshot of the grain positions in the middle of the transport process is shown in [Figure 2](#). The grains are colored based on their release time. The inclination and the gap between the blade and the tube causes some grains to be left behind at one end of the tube, while most of the grains are transported to the other end. There grain colors indicate that some amount of mixing occurs during the transport.

The forces experienced by the screw due to the grain impact is an important factor in the design and operation of a screw conveyor. [Figure 3](#) shows the forces at the same instant of time as in [Figure 2](#). It is clear that the maximum forces are experienced near the parts of the screw that is exposed to the largest number of grains. These forces can then be used to evaluate the power draw required to operate the conveyor and the wear rate of the screw blades.

Finally, [Figure 4](#) presents the plot of the mass-flow rate as defined as the overall rate mass of the grains that transit an imaginary plane. Since the plane is located in the middle of the tube, the calculated flow rate is 0 in the beginning. It slowly rises until it reaches a peak of about 3.8 kg/s before it starts decreasing as the bulk of the grains pass through the plane. This peak could be interpreted as the overall mass-flow rate of the device when operated under similar conditions in a continuous configuration as opposed to the batch configuration used in this model.

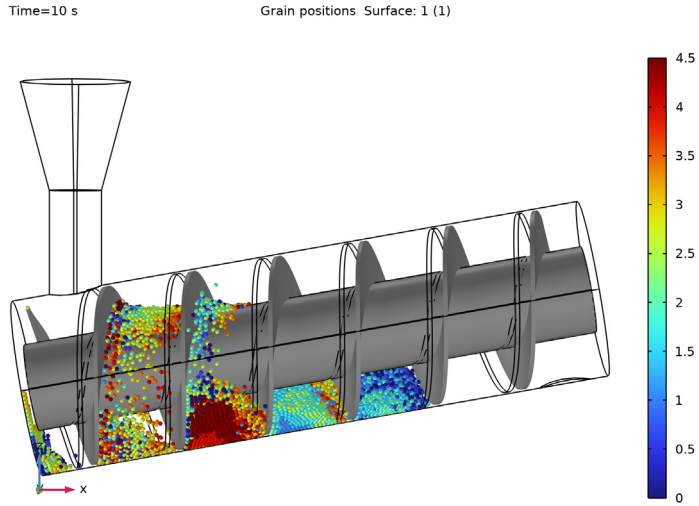

Figure 2: Grain positions at the end of 10 seconds. The grains are colored by their release time.

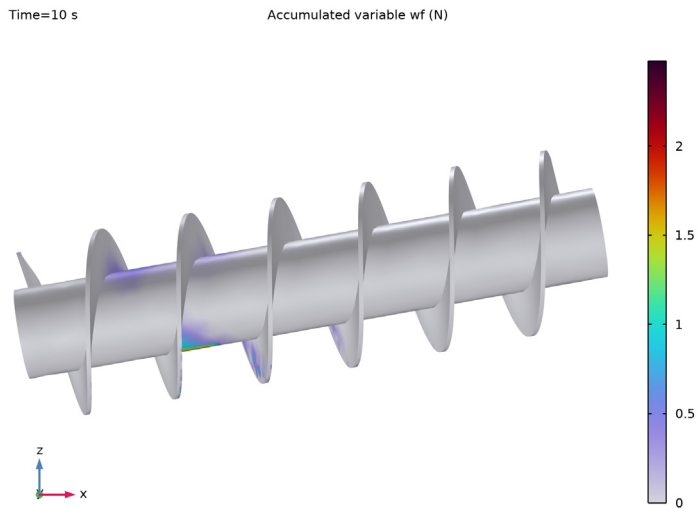

Figure 3: Forces on the screw at the end of 10 seconds.

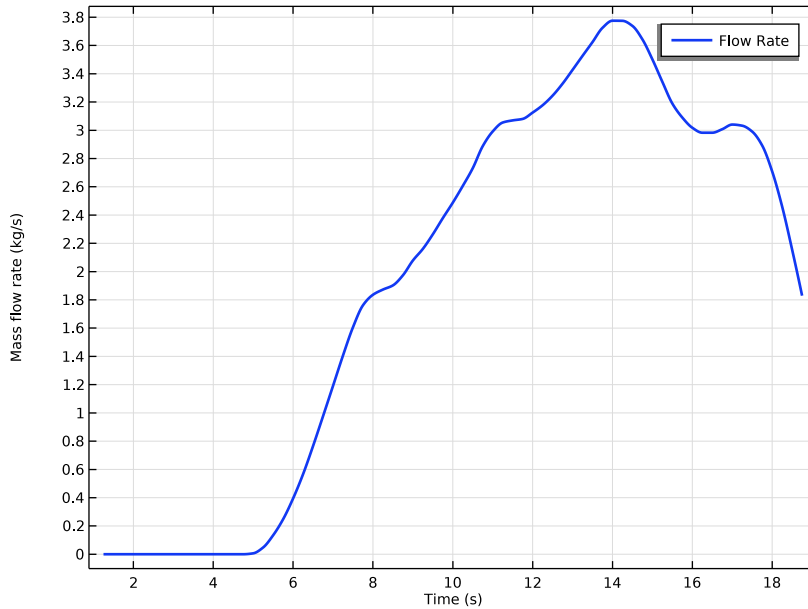



Figure 4: Mass-flow rate as a function of time.

Application Library path: Granular_Flow_Module/Transport/screw_conveyor



Modeling Instructions

From the **Main Toolbar** menu, choose **New**.

NEW

In the **New** window, click  **Model Wizard**.

MODEL WIZARD

- 1 In the **Model Wizard** window, click  **3D**.
- 2 In the **Select Physics** tree, select **Fluid Flow > Granular Flow (gran)**.
- 3 Click **Add**.
- 4 Click  **Study**.

5 In the **Select Study** tree, select **General Studies > Time Dependent**.

6 Click  **Done**.

GEOMETRY I

1 In the **Geometry** toolbar, click **Insert Sequence** and choose **Insert Sequence**.

2 Browse to the model's Application Libraries folder and double-click the file `screw_conveyor_geom_sequence.mph`.

3 In the **Geometry** toolbar, click  **Build All**.

4 Click the  **Transparency** button in the **Graphics** toolbar.

5 Click the  **Show Grid** button in the **Graphics** toolbar.

6 Click the  **Zoom Extents** button in the **Graphics** toolbar. The geometry should look like [Figure 1](#).

GLOBAL DEFINITIONS

Parameters 2

1 In the **Home** toolbar, click  **Parameters** and choose **Add > Parameters**.

2 In the **Settings** window for **Parameters**, locate the **Parameters** section.

3 In the table, enter the following settings:

Name	Expression	Value	Description
dg	10[mm]	0.01 m	Grain diameter
om	120[rpm]	2 1/s	Angular speed
N	2500	2500	Number of grains per release

GEOMETRY I

Work Plane 3 (wp3)

1 In the **Geometry** toolbar, click  **Work Plane**.

2 In the **Settings** window for **Work Plane**, locate the **Plane Definition** section.

3 From the **Plane type** list, choose **Edge angle**.

4 On the object **del1**, select Edge 3 only.

5 Click to select the  **Activate Selection** toggle button for **Face adjacent to edge**.

6 On the object **del1**, select Boundary 2 only.

7 Select the **Reverse normal direction** checkbox.

- In the **Definitions** toolbar, click  **Coordinate Systems** and choose **System from Geometry**.

DEFINITIONS

System from Geometry 2 (sys2)

- In the **Settings** window for **System from Geometry**, locate the **System from Geometry** section.
- From the **Work plane** list, choose **Work Plane 3 (wp3)**.





Variables 1

- In the **Home** toolbar, click  **Variables** and choose **Local Variables**.
- In the **Settings** window for **Variables**, locate the **Variables** section.
- In the table, enter the following settings:

Name	Expression	Unit	Description
include	$\text{gran.mg} * (\text{abs}(\text{sys2.x1} - (\text{L} + 2 * \text{sw}) / 2) < \text{dg} / 2)$	kg	Boolean for inclusion

MATERIALS

Grains

- In the **Materials** toolbar, click  **Blank Material**.
- In the **Settings** window for **Material**, type Grains in the **Label** text field.
- Click to expand the **Material Properties** section. In the **Material properties** tree, select **Basic Properties > Density**.
- Click  **Add to Material**.
- In the **Material properties** tree, select **Basic Properties > Poisson's Ratio**.
- Click  **Add to Material**.
- In the **Material properties** tree, select **Basic Properties > Young's Modulus**.
- Click  **Add to Material**.
- Locate the **Material Contents** section. In the table, enter the following settings:

Property	Variable	Value	Unit	Property group
Density	rho	4200	kg/m ³	Basic
Poisson's ratio	nu	0.4		Basic
Young's modulus	E	11 [MPa]	Pa	Basic

Walls

- 1 In the **Materials** toolbar, click  **Blank Material**.
- 2 In the **Settings** window for **Material**, type Walls in the **Label** text field.
- 3 Locate the **Geometric Entity Selection** section. From the **Geometric entity level** list, choose **Boundary**.
- 4 From the **Selection** list, choose **All boundaries**.
- 5 Locate the **Material Contents** section. In the table, enter the following settings:

Property	Variable	Value	Unit	Property group
Young's modulus	E	25 [MPa]	Pa	Basic
Poisson's ratio	nu	0.35	l	Basic

GRANULAR FLOW (GRAN)

Grain Properties I

- 1 In the **Model Builder** window, under **Component 1 (comp1) > Granular Flow (gran)** click **Grain Properties I**.
- 2 In the **Settings** window for **Grain Properties**, locate the **Granular Material Properties** section.
- 3 From the **Granular material** list, choose **Grains (mat1)**.
- 4 Locate the **Size** section. In the d_g text field, type dg.

Release I

- 1 In the **Physics** toolbar, click  **Domains** and choose **Release**.
- 2 Select Domain 2 only.
- 3 In the **Settings** window for **Release**, locate the **Release Times** section.
- 4 In the **Release times** text field, type range(0,0.5,4.5).
- 5 Locate the **Released Grain Properties** section. In the table, enter the following settings:

Released grain properties	Number of grains
Grain Properties I	N

Screw

- 1 In the **Physics** toolbar, click  **Boundaries** and choose **Wall**.
- 2 In the **Settings** window for **Wall**, type Screw in the **Label** text field.
- 3 Locate the **Boundary Selection** section. From the **Selection** list, choose **Screw**.

- 4 Locate the **Wall Movement** section. From the **Wall motion** list, choose **Rotation**.
- 5 In the ω text field, type om.
- 6 Specify the e_{ax} vector as

sys2.e_x11	X
sys2.e_x12	Y
sys2.e_x13	Z

Force Accumulator I

In the **Physics** toolbar, click  **Attributes** and choose **Force Accumulator**.

Contact Between Grains I

- 1 In the **Model Builder** window, under **Component 1 (comp1) > Granular Flow (gran)** click **Contact Between Grains I**.
- 2 In the **Settings** window for **Contact Between Grains**, locate the **Contact Properties** section.
- 3 In the e_n text field, type 0.8.
- 4 In the e_t text field, type 0.7.
- 5 In the μ_s text field, type 0.4.
- 6 In the μ_T text field, type 0.3.
- 7 In the μ_{tw} text field, type 0.25.

Contact with Walls I

- 1 In the **Model Builder** window, click **Contact with Walls I**.
- 2 In the **Settings** window for **Contact with Walls**, locate the **Contact Properties** section.
- 3 In the e_n text field, type 0.85.
- 4 In the e_t text field, type 0.76.
- 5 In the μ_s text field, type 0.5.
- 6 In the μ_T text field, type 0.2.
- 7 In the μ_{tw} text field, type 0.18.

Outlet I

- 1 In the **Physics** toolbar, click  **Boundaries** and choose **Outlet**.
- 2 Select Boundaries 21, 71, and 72 only.

Bounding Box I

- 1 In the **Physics** toolbar, click  **Global** and choose **Bounding Box**.
- 2 In the **Settings** window for **Bounding Box**, locate the **Settings** section.

- 3 From the **Specify bounding box** list, choose **From geometry**.



STUDY I

Step 1: Time Dependent

- 1 In the **Model Builder** window, under **Study I** click **Step 1: Time Dependent**.
- 2 In the **Settings** window for **Time Dependent**, locate the **Study Settings** section.
- 3 In the **Output times** text field, type range (0,0.25,20).
- 4 In the **Study** toolbar, click  **Compute**.

RESULTS

Grain Positions (gran)

- 1 In the **Settings** window for **3D Plot Group**, locate the **Data** section.
- 2 From the **Time (s)** list, choose **10**.
- 3 Click the  **Transparency** button in the **Graphics** toolbar.
- 4 Click the  **Go to XZ View** button in the **Graphics** toolbar.
- 5 Click the  **Zoom Extents** button in the **Graphics** toolbar.
- 6 In the **Model Builder** window, expand the **Grain Positions (gran)** node.

Color Expression 1

- 1 In the **Model Builder** window, expand the **Results > Grain Positions (gran) > Grain Positions 1** node, then click **Color Expression 1**.
- 2 In the **Settings** window for **Color Expression**, locate the **Expression** section.
- 3 In the **Expression** text field, type `gran.rti`.
- 4 In the **Grain Positions (gran)** toolbar, click  **Plot**. The plot should look like [Figure 2](#).

Forces on the screw

- 1 In the **Results** toolbar, click  **3D Plot Group**.
- 2 In the **Settings** window for **3D Plot Group**, type `Forces on the screw` in the **Label** text field.
- 3 Locate the **Data** section. From the **Dataset** list, choose **Grain 1**.
- 4 From the **Time (s)** list, choose **10**.
- 5 Locate the **Plot Settings** section. Clear the **Plot dataset edges** checkbox.

Surface 1

- 1 In the **Forces on the screw** toolbar, click  **Surface**.

- 2 In the **Settings** window for **Surface**, locate the **Expression** section.
- 3 In the **Expression** text field, type `gran.wp2.facc1.wf`.
- 4 Locate the **Coloring and Style** section. From the **Color table** list, choose **PrismDark**.



Deformation 1

- 1 In the **Forces on the screw** toolbar, click  **Deformation**.
- 2 In the **Settings** window for **Deformation**, locate the **Expression** section.
- 3 In the **x-component** text field, type `comp1.gran.x-x`.
- 4 In the **y-component** text field, type `comp1.gran.y-y`.
- 5 In the **z-component** text field, type `comp1.gran.z-z`.
- 6 Locate the **Scale** section.
- 7 Select the **Scale factor** checkbox. In the associated text field, type `1.0`.



Surface 1

In the **Model Builder** window, click **Surface 1**.

Selection 1

- 1 In the **Forces on the screw** toolbar, click  **Selection**.
- 2 In the **Settings** window for **Selection**, locate the **Selection** section.
- 3 From the **Selection** list, choose **Screw**.
- 4 In the **Forces on the screw** toolbar, click  **Plot**. The plot should look like [Figure 3](#).

Grain Positions

- 1 In the **Forces on the screw** toolbar, click  **Animation** and choose **Player**.
- 2 In the **Settings** window for **Animation**, type `Grain Positions` in the **Label** text field.
- 3 Locate the **Scene** section. From the **Subject** list, choose **Grain Positions (gran)**.
- 4 Locate the **Frames** section. From the **Frame selection** list, choose **All**.
- 5 Click the  **Play** button in the **Graphics** toolbar. This plays the animation of the grains being transported by the screw conveyor.

Forces on the Screw

- 1 Right-click **Grain Positions** and choose **Duplicate**.
- 2 In the **Settings** window for **Animation**, type `Forces on the Screw` in the **Label** text field.
- 3 Locate the **Scene** section. From the **Subject** list, choose **Forces on the screw**.
- 4 Click the  **Play** button in the **Graphics** toolbar. This plays the animation of the forces on the screw conveyor resulting from the grain-wall contacts.

APPLICATION BUILDER

The mass flow rate can be computed using an Application Method. These may be added to an existing model via a **Model Method** using the **Application Builder**. Note that the **Application Builder** is only available in the Windows® version of the COMSOL Desktop. But once the **Model Method** is created, it can be run in both the Linux and Mac versions.

In the **Home** toolbar, click  **Application Builder**.

METHODS

The code for the computing and plotting the mass flow rate can be simplified by using utility classes.

util1

- 1 In the **Home** toolbar, click  **More Libraries** and choose **Utility Class**.
- 2 In the **Application Builder** window, right-click **util1** and choose **Edit**.
- 3 Copy the code for the utilities `createGrainEval`, `createGridDataSets`, `updateDatsets`, `plotFlowRate` and `getPlotFeature` and paste it into the **Utility Class** editor for `util1`.

```
// Create the Grain evaluations
public static NumericalFeature createGrainEval(String tag, String data, String
level, NumericalFeatureList numericalList) {
    NumericalFeature grn;
    if (numericalList.index(tag) == -1)
        grn = model.result().numerical().create(tag, "Grain");
    else
        grn = numericalList.get(tag);
    grn.setIndex("looplevelinput", level, 0);
    grn.set("data", data);
    return grn;
}

/* Create the interpolation functions and the grid data sets*/
public static void createGridDataSets(String[] myTags, int num_steps,
double[][] data) {
    FunctionFeatureList functionList = model.func();
    FunctionFeature functionFeature;

    for (int i = 0; i < myTags.length; i++) {
        if (functionList.index(myTags[i]) == -1) {
            functionFeature = functionList.create(myTags[i], "Interpolation");
            functionFeature.label(myTags[i]);
            with(functionFeature);
                set("funcname", myTags[i]);
                set("interp", "piecewisecubic");
                set("extrap", "const");
                set("defineprimfun", true);
            endwith();
        }
    }
}
```

```

else {
    functionFeature = functionList.get(myTags[i]);
}

with(functionFeature);
    set("table", new String[0][0]);
    for (int k = 0; k < num_steps; k++) {
        setIndex("table", data[k][0], k, 0);
        setIndex("table", data[k][i+1], k, 1);
    }
endwith();

String pmin = toString(data[0][0]);
String pmax = toString(data[num_steps-1][0]);
String[] params = {pmin, pmax, "out"};
util1.updateDatsets(i, params, myTags);
}
}

/** Create or update the grid datasets. */
public static void updateDatsets(int i, String[] param,
                                String[] tagList) {

    DatasetFeature dataFeature;
    if (model.result().dataset().index(tagList[i]) == -1) {
        dataFeature = model.result().dataset().create(tagList[i], "Grid1D");
        dataFeature.label(tagList[i]);
    }
    else {
        dataFeature = model.result().dataset().get(tagList[i]);
    }
    with(dataFeature);
        set("source", "function");
        set("function", tagList[i]);
        set("parmin1", param[0]);
        set("parmax1", param[1]);
        set("par1", param[2]);
    endwith();
}

/* Add the line plots for the flow rate */
public static void plotFlowRate(String[] myList, String[] myTags)
{
    // Create or get the plot group
    ResultFeature myPlot = util1.getPlotFeature("Flow Rate");
    // Create or get the line graphs
    ResultFeatureList myPlotList = myPlot.feature();

    int num_plots = myList.length;
    for (int i = 0; i < num_plots; i++) {
        if (myPlotList.index(myTags[i]) == -1) {
            ResultFeature miPlotLine = myPlot.create(myTags[i], "LineGraph");
            String expr_str = myTags[i]+"(out)";
            with(miPlotLine);
                set("xdata", "expr");
                set("expr", expr_str);

```

```

        set("xdataexpr", "out");
        set("xdatadescractive", true);
        set("xdatadescr", "Time (s)");
        set("data", myTags[i]);
        set("descr", "Flow Rate");
        set("legend", true);
        set("autodescr", true);
        set("autosolution", false);
        set("descriptive", true);
        set("smooth", "none");
        set("resolution", "norefine");
        set("linewidth", 2);
    endwhile();
}
}
}

/** Create or get the plot feature. */
public static ResultFeature getPlotFeature(String pLabel) {
    ResultFeature myPlot;
    String pTag = "";
    String pLabel_in = pLabel;
    String[] rTag = model.result().tags();

    for (int i = 0; i < rTag.length; i++) {
        if (findIn(model.result(rTag[i]).label(), pLabel_in) > -1) {
            pTag = rTag[i];
            pLabel = model.result(rTag[i]).label();
        }
    }

    if (pTag.length() == 0) {
        pTag = model.result().uniquetag("pg");
        myPlot = model.result().create(pTag, "PlotGroup1D");
        myPlot.label(pLabel);
        with(myPlot);
            set("data", "none");
            set("titletype", "none");
            set("legendpos", "upperright");
            set("ylabelactive", true);
            set("ylabel", "Mass flow rate (kg/s)");
        endwhile();
    }
    else
        myPlot = model.result().get(pTag);
    return myPlot;
}

```

GLOBAL METHOD

Now add a **Model Method** to compute the mass flow rate that uses the utility functions.

I In the **Home** toolbar, click **New Method** and choose **Global Method**.

- 2 In the **Global Method** dialog, type `computeMassFlowRate` in the **Name** text field.
- 3 Click **OK**.
- 4 Add the inputs and their default values for the method `computeMassFlowRate`.
- 5 In the **Settings** window for **Method**, locate the **Inputs and Output** section.
- 6 Find the **Inputs** subsection. Click **+ Add**.
- 7 In the table, enter the following settings:

Name	Type	Default	Description	Unit
window	String	11	Length of smoothing window	

computeMassFlowRate

- 1 In the **Application Builder** window, under **Methods** click **computeMassFlowRate**.
- 2 Copy the code for method `computeMassFlowRate` and paste it into the **Method** editor.

```
int twin = Integer.parseInt(window);
if (twin%2 == 0)
    twin++;

NumericalFeatureList numericalList = model.result().numerical();
NumericalFeature grn1 = util1.createGrainEval("grn1", "gran1", "all",
numericalList);
grn1.set("expr", "include");
double[][] out = transpose(grn1.getReal());

// Get the output time parameters
String tlist = model.study("std1").feature("time").getString("tlist");
String[] tlist_arr = tlist.split(",");
double t_beg = model.param().evaluate(tlist_arr[0].split("\\(")[1]);
double dt = model.param().evaluate(tlist_arr[1]);

int numSteps = out.length;
int numGrains = out[0].length;



double[][] flowRate = new double[numSteps-twin+1][2];
for (int i = twin/2; i < numSteps-twin/2; i++) {
    flowRate[i-twin/2][0] = t_beg+i*dt;
    flowRate[i-twin/2][1] = 0;
    for (int j = 0; j < numGrains; j++) {
        for (int k = i-twin/2; k <= i+twin/2; k++) {
            if (out[k][j] > 0.0) {
                flowRate[i-twin/2][1] += out[k][j];
                break;
            }
        }
    }
    flowRate[i-twin/2][1] /= (twin*dt);
}

String[] myList = new String[]{"FlowRate"};
```

```
String[] myTags = new String[]{"flr"};

util1.createGridDataSets(myTags, flowRate.length, flowRate);
util1.plotFlowRate(myList, myTags);
```

METHODS

- 1 In the **Home** toolbar, click  **Model Builder** to switch to the main desktop.
Add a **Method Call** to computeMassFlowRate in order to run it.
- 2 In the **Developer** toolbar, click  **Method Call** and choose **computeMassFlowRate**.

GLOBAL DEFINITIONS

Compute Mass Flow Rate

- 1 In the **Model Builder** window, under **Global Definitions** click **ComputeMassFlowRate 1**.
- 2 In the **Settings** window for **Method Call**, type Compute Mass Flow Rate in the **Label** text field.
- 3 Click  **Run**. Click **Yes** if the Confirm Run Method dialogue box appears. This produces an **Interpolation** feature which is then used to create the plot of the mass flow rate as a function of time.

RESULTS

Flow Rate

- 1 In the **Model Builder** window, under **Results** click **Flow Rate**.
- 2 In the **Flow Rate** toolbar, click  **Plot**. The plot of the mass flow rate as a function of time should look like [Figure 4](#).



Appendix: Geometry Instructions

From the **Main Toolbar** menu, choose **New**.

NEW

In the **New** window, click  **Model Wizard**.

MODEL WIZARD

- 1 In the **Model Wizard** window, click  **3D**.
- 2 Click  **Done**.

GLOBAL DEFINITIONS

Parameters 1



- 1 In the **Model Builder** window, under **Global Definitions** click **Parameters 1**.
- 2 In the **Settings** window for **Parameters**, locate the **Parameters** section.
- 3 Click  **Load from File**.
- 4 Browse to the model's Application Libraries folder and double-click the file `screw_conveyor_geom_sequence_parameters.txt`.

GEOMETRY 1

Cylinder 1 (cyl1)

- 1 In the **Geometry** toolbar, click  **Cylinder**.
- 2 In the **Settings** window for **Cylinder**, locate the **Size and Shape** section.
- 3 In the **Radius** text field, type R₀.
- 4 In the **Height** text field, type L.
- 5 Locate the **Axis** section. From the **Axis type** list, choose **x-axis**.

Cylinder 2 (cyl2)

- 1 In the **Geometry** toolbar, click  **Cylinder**.
- 2 In the **Settings** window for **Cylinder**, locate the **Size and Shape** section.
- 3 In the **Radius** text field, type R_i.
- 4 In the **Height** text field, type L.
- 5 Locate the **Axis** section. From the **Axis type** list, choose **x-axis**.
- 6 Click the  **Transparency** button in the **Graphics** toolbar.

Helix 1 (hel1)

- 1 In the **Geometry** toolbar, click  **Helix**.
- 2 In the **Settings** window for **Helix**, locate the **Size and Shape** section.
- 3 In the **Number of turns** text field, type n.
- 4 In the **Major radius** text field, type R_m.
- 5 In the **Minor radius** text field, type 0.
- 6 In the **Axial pitch** text field, type p.
- 7 From the **Chirality** list, choose **Left-handed**.
- 8 From the **End caps** list, choose **Perpendicular to spine**.
- 9 Locate the **Position** section. In the **x** text field, type p/8.

- 10 Locate the **Axis** section. From the **Axis type** list, choose **x-axis**.
- 11 Locate the **Rotation Angle** section. In the **Rotation** text field, type 90.

Work Plane 1 (wp1)

In the **Geometry** toolbar, click  **Work Plane**.



Work Plane 1 (wp1) > Plane Geometry

In the **Model Builder** window, click **Plane Geometry**.

Work Plane 1 (wp1) > Rectangle 1 (r1)

- 1 In the **Work Plane** toolbar, click  **Rectangle**.
- 2 In the **Settings** window for **Rectangle**, locate the **Size and Shape** section.
- 3 In the **Width** text field, type sw.
- 4 In the **Height** text field, type sh.
- 5 Locate the **Position** section. From the **Base** list, choose **Center**.
- 6 In the **xw** text field, type p/8.
- 7 In the **yw** text field, type Rm.
- 8 Locate the **Rotation Angle** section. In the **Rotation** text field, type alpha.

Sweep 1 (swel)

- 1 In the **Model Builder** window, right-click **Geometry 1** and choose **Sweep**.
- 2 On the object **wp1**, select Boundary 1 only.
- 3 In the **Settings** window for **Sweep**, locate the **Spine Curve** section.
- 4 Click to select the  **Activate Selection** toggle button for **Edges to follow**.
- 5 On the object **hell**, select Edge 1 only.
- 6 Find the **Alignment at start** subsection. Select the **Make spine perpendicular to entities to sweep** checkbox.
- 7 Locate the **Input Object Handling** section. Clear the **Keep input objects** checkbox.
- 8 Locate the **Motion of Cross Section** section. From the **Twisting** list, choose **Follow curvature vector**.
- 9 Click  **Build Selected**.

Partition Objects 1 (par1)

- 1 In the **Geometry** toolbar, click  **Booleans and Partitions** and choose **Partition Objects**.
- 2 Select the object **swel** only.
- 3 In the **Settings** window for **Partition Objects**, locate the **Partition Objects** section.

- 4 Click to select the  **Activate Selection** toggle button for **Tool objects**.
- 5 Select the object **cyl1** only.

Extract 1 (extract1)

- 1 In the **Geometry** toolbar, click  **Extract**.
- 2 In the **Settings** window for **Extract**, locate the **Entities or Objects to Extract** section.
- 3 From the **Geometric entity level** list, choose **Domain**.
- 4 On the object **par1**, select Domain 2 only.
- 5 From the **Input object handling** list, choose **Remove**.

Union 1 (uni1)

- 1 In the **Geometry** toolbar, click  **Booleans and Partitions** and choose **Union**.
- 2 Click in the **Graphics** window and then press Ctrl+A to select both objects.

Cylinder 3 (cyl3)

- 1 In the **Geometry** toolbar, click  **Cylinder**.
- 2 In the **Settings** window for **Cylinder**, locate the **Size and Shape** section.
- 3 In the **Radius** text field, type $R_0 + gap$.
- 4 In the **Height** text field, type $L + 2 * sw$.
- 5 Locate the **Position** section. In the **x** text field, type $-sw$.
- 6 Locate the **Axis** section. From the **Axis type** list, choose **x-axis**.



Work Plane 2 (wp2)

- 1 In the **Geometry** toolbar, click  **Work Plane**.
- 2 In the **Settings** window for **Work Plane**, locate the **Plane Definition** section.
- 3 In the **z-coordinate** text field, type $-R_0 * 1.2$.

Work Plane 2 (wp2) > Plane Geometry

In the **Model Builder** window, click **Plane Geometry**.

Work Plane 2 (wp2) > Circle 1 (c1)

- 1 In the **Work Plane** toolbar, click  **Circle**.
- 2 In the **Settings** window for **Circle**, locate the **Size and Shape** section.
- 3 In the **Radius** text field, type $chute_R$.
- 4 Locate the **Position** section. In the **xw** text field, type $L - chute_R * 1.5$.
- 5 Click  **Build Selected**.

Extrude 1 (ext1)

- 1 In the **Model Builder** window, right-click **Geometry 1** and choose **Extrude**.
- 2 In the **Settings** window for **Extrude**, locate the **Distances** section.
- 3 In the table, enter the following settings:

Distances (m)

$$0.2 * R_o + (R_o - R_i) / 2$$

Rotate 1 (rot1)

- 1 In the **Geometry** toolbar, click  **Transforms** and choose **Rotate**.
- 2 In the **Settings** window for **Rotate**, locate the **Input** section.
- 3 From the **Input objects** list, choose **All objects**.
- 4 Locate the **Rotation** section. From the **Axis type** list, choose **y-axis**.
- 5 In the **Angle** text field, type $-inc1$.

Cylinder 4 (cyl4)

- 1 In the **Geometry** toolbar, click  **Cylinder**.
- 2 In the **Settings** window for **Cylinder**, locate the **Size and Shape** section.
- 3 In the **Radius** text field, type $chute_R$.
- 4 In the **Height** text field, type $chute_H$.
- 5 Locate the **Position** section. In the **x** text field, type $p/2$.
- 6 In the **z** text field, type $R_o + gap$.

Cone 1 (cone1)



- 1 In the **Geometry** toolbar, click  **Cone**.
- 2 In the **Settings** window for **Cone**, locate the **Size and Shape** section.
- 3 In the **Bottom radius** text field, type $chute_R$.
- 4 In the **Height** text field, type $chute_H$.
- 5 In the **Top radius** text field, type $chute_R + chute_H * \tan(\theta)$.
- 6 Locate the **Position** section. In the **x** text field, type $p/2$.
- 7 In the **z** text field, type $R_o + gap + chute_H$.

Union 2 (uni2)



- 1 In the **Geometry** toolbar, click  **Booleans and Partitions** and choose **Union**.
- 2 Select the objects **cyl4** and **rot1(2)** only.
- 3 In the **Settings** window for **Union**, locate the **Union** section.

4 Clear the **Keep interior boundaries** checkbox.

Difference 1 (dif1)

- 1 In the **Geometry** toolbar, click  **Booleans and Partitions** and choose **Difference**.
- 2 Select the object **uni2** only.
- 3 In the **Settings** window for **Difference**, locate the **Difference** section.
- 4 Click to select the  **Activate Selection** toggle button for **Objects to subtract**.
- 5 Select the object **rot1(1)** only.
- 6 Locate the **Selections of Resulting Entities** section. Select the **Resulting objects selection** checkbox.
- 7 From the **Show in physics** list, choose **Off**.

Difference 2 (dif2)

- 1 In the **Geometry** toolbar, click  **Booleans and Partitions** and choose **Difference**.
- 2 Select the object **dif1** only.
- 3 In the **Settings** window for **Difference**, locate the **Difference** section.
- 4 Click to select the  **Activate Selection** toggle button for **Objects to subtract**.
- 5 Select the object **rot1(3)** only.
- 6 Select the **Keep objects to add** checkbox.
- 7 Clear the **Keep interior boundaries** checkbox.
- 8 Click  **Build Selected**.

Delete Entities 1 (dell)



- 1 In the **Geometry** toolbar, click  **Delete**.
- 2 In the **Settings** window for **Delete Entities**, locate the **Entities or Objects to Delete** section.
- 3 From the **Geometric entity level** list, choose **Boundary**.
- 4 On the object **dif2**, select Boundaries 67–69, 72, and 73 only.

Form Union (fin)

In the **Geometry** toolbar, click  **Build All**.

Screw

- 1 In the **Geometry** toolbar, click  **Selections** and choose **Adjacent Selection**.
- 2 In the **Settings** window for **Adjacent Selection**, type **Screw** in the **Label** text field.
- 3 Locate the **Input Entities** section. Click  **Add**.

- 4 In the **Add** dialog, select **Difference I** in the **Input selections** list.
- 5 Click **OK**.
- 6 In the **Settings** window for **Adjacent Selection**, locate the **Output Entities** section.
- 7 From the **Exterior boundaries** list, choose **Adjacent to inside**.
- 8 In the **Geometry** toolbar, click  **Build All**.
- 9 Click  **Cleanup Wizard**.

CLEANUP WIZARD

- 1 Go to the **Cleanup Wizard** window.
- 2 Click the **Apply** button in the window toolbar.
- 3 Click the **Apply** button in the window toolbar.
- 4 Click the **Done** button in the window toolbar.