



Model created in COMSOL Multiphysics 6.4

# Powder Spreading Using a Moving Roller

## *Introduction*

---

Additive manufacturing techniques such as powder bed fusion (PBF) rely on obtaining thin uniform layers of powdered materials. The quality and the consistency of the obtained powder bed has a significant impact on the quality of the manufacturing process. The factors affecting the quality of the bed include its density, homogeneity, and thickness as well as the presence of any defects. This crucial step is most often achieved by first generating a heap of the powdered material in front of the bed. A moving roller is then used to spread the material onto the bed. The geometry and speed of the roller can affect the quality of the powder bed.

This example uses the Granular Flow interface to model the formation of the grain heap and then its subsequent spreading using a cylindrical roller. The roller has a combined rotational and translational motion. The resulting powder bed is then analyzed to determine its quality based on its packing fraction. Additional packing characteristics such as the distribution of the grain center heights and the coordination numbers are also evaluated.

This model also demonstrates the process of restarting the granular flow simulations whereby the information of the grains from one study step is used as the initial conditions for a subsequent study step.

## *Model Definition*

---

The geometry consists of three rectangular compartments. The first one houses the roller until it is ready to move. The grains are released into the middle compartment. The third compartment represents the powder bed. The length and the width of the middle compartment is 40 mm. The length of the powder bed is set to 200 mm, and the height of all the compartments is 60 mm. The roller has a diameter of 15 mm and is initially situated in the first compartment such that it has a gap of 3 mm from both its walls in the  $x$  direction. The geometry is presented in [Figure 1](#). The two boundaries that separate the middle compartment from the other two represent gates that can be added and removed to alter the geometry.

A total of 20,000 grains, each having a diameter of 1 mm, are first released randomly into the middle compartment. The grains initially settle under the influence of gravity for 0.25 s to form a compact bed since the two gates are closed. Periodic boundary conditions are applied along the  $y$  directions to isolate the wall effects in this direction. Once the grains are settled, the two gates are lifted to allow the grains to form a stable heap. The heap formation time is 0.4 s.

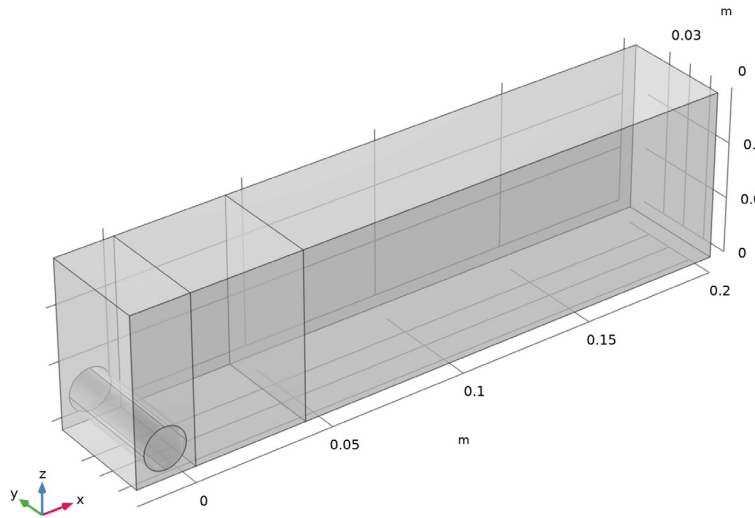

*Figure 1: Model geometry.*

Finally, the roller blade is allowed to move with a translational speed of 100 mm/s for a total linear traversal length of 163 mm. The roller also rotates with an angular speed of 6 rad/s around its axis. This action causes the powder spreading and the formation of a compact powder bed.

### *Notes on COMSOL Implementation*

The model is solved using three studies. In the first study, the grains are released into the middle compartment and are allowed to settle. The degrees of freedom of the grains at the end of this study are used to initialize the second study in which the gates are removed instantaneously to allow for the heap formation. The removal of these gates is achieved by using the **Outlet** feature. Once the heap is stable, the degrees of freedom are then used to initialize the third study wherein the roller is allowed to move. The motion of the roller is controlled by the **Wall Movement** settings in the **Wall** feature. The **Periodic Condition** feature is used in the *y* direction to eliminate the wall effects in that direction.

Once the powder bed is generated, its quality is judged based on two parameters: the packing fraction and the height of the grains as a function of the *x*-coordinate. To calculate the packing fraction, the resultant powder bed is first divided into multiple samples along

the  $x$  direction with a sample width of 10 mm. A **ID Histogram** feature is then used to count the number of grains within each sample and the result is stored in a table. An **Interpolation** feature is then created to convert the data in this table into a function of the sample index or the  $x$ -coordinate representing the center of each sample. The packing fraction in each sample is then evaluated as the product of the number of grains in each sample and the volume of each grain divided by the ideal volume of the sample.

## Results and Discussion

Figure 2 shows the grain positions at the end of the first study colored by their speed in m/s. The speeds are very low, indicating that the grains have settled under gravity and have formed a stable pile.

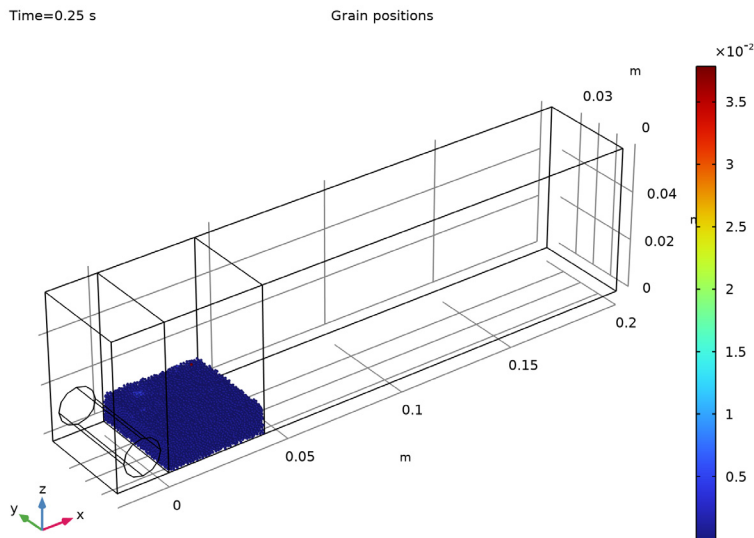
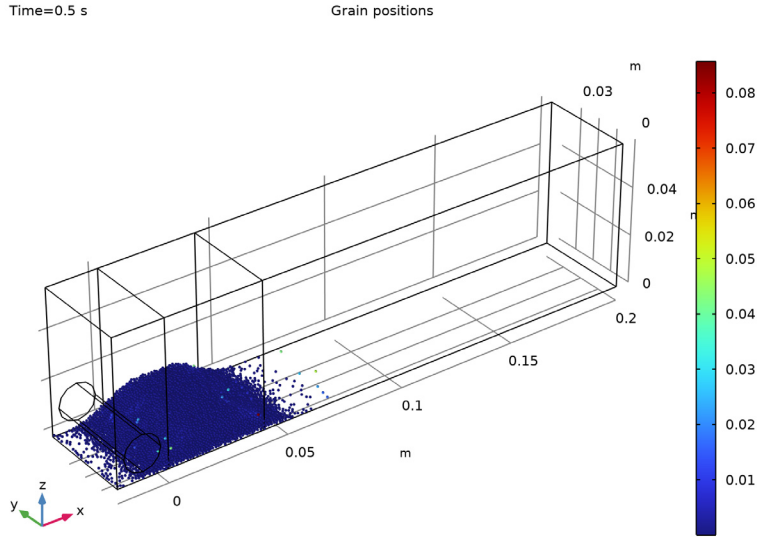

Figure 2: The middle compartment filled with grains. The grains are colored based on their speeds in m/s.

Figure 3 shows the grain positions at the end of the second study, again colored by their speed in m/s. The lifting of the two gates allows the formation of a nearly symmetric heap that can then be rolled over. The speeds of the grains in the heap are again very low, indicating that the grains have formed a stable heap.



*Figure 3: Heap of grains formed after the two boundaries are removed. The grains are colored by their speed in m/s.*

The grain positions at the end of the third study are shown in [Figure 4](#) and are colored by their coordination numbers. It is visually evident that the powder bed is pretty uniform in density without any major gaps in the bed. This property of the bed quality is quantified by the packing fraction, which is plotted as a function of the  $x$ -coordinate in [Figure 5](#). The packing fraction is clearly almost constant for every sample with a value of roughly 0.47 throughout the bed. This illustrates the density and the uniformity of the powder bed.

[Figure 6](#) shows the normalized histogram of the  $z$ -coordinates of the grains in the powder bed. The  $x$ -axis in the plot is the  $z$ -coordinate normalized by the grain diameter. There are three distinct peaks in the distribution. The first peak occurs at 0.5 indicating the first layer is in contact with the base of the bed. The second peak occurs at 1.3 which is approximately equal to  $\frac{1}{2} + \frac{\sqrt{2}}{\sqrt{3}}$  which would be expected from a closely packed periodic structure. The broadness of this peak also denotes some additional variance in the height of the second layer. Finally, there is an additional much broader third peak at 2.1 which is approximately equal to  $\frac{1}{2} + 2\frac{\sqrt{2}}{\sqrt{3}}$  which corresponds to the third layer in a closely packed periodic structure. Note that these peaks are identical to the ones observed in [Ref. 1](#) where the powder spreading is achieved through the linear translation of a rectangular blade.

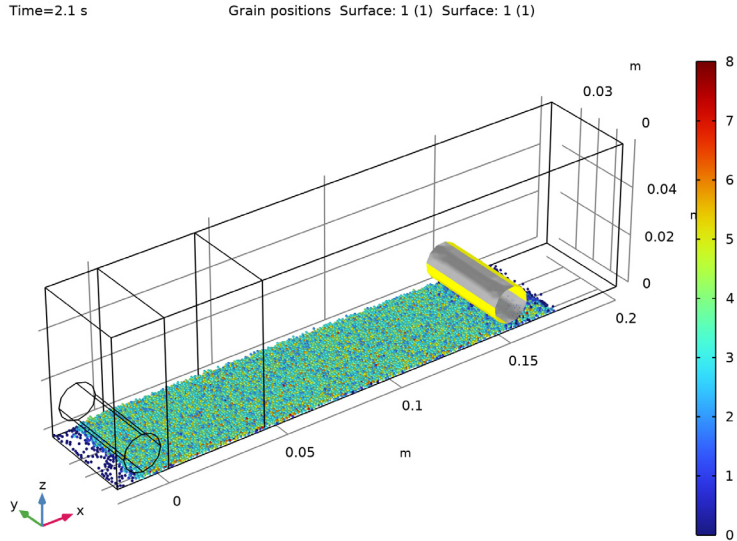

*Figure 4: The powder bed formed due the motion of the roller. The grains are colored by their coordination numbers.*

Figure 7 shows the normalized histogram of the grain coordination numbers. The plot has a strong peak at three, thus indicating that a large portion of the grains are in contact with three additional grains. However, there is also a very small fraction of the grains that are in contact with nine additional grains. This is indicative of the pockets of high compaction in the powder bed.

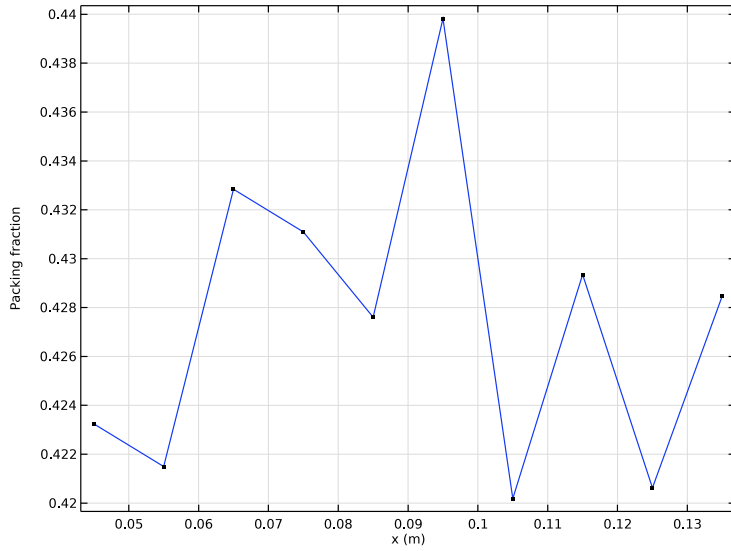

Figure 5: Packing fraction of the grains as a function of the  $x$ -coordinate in the powder bed.

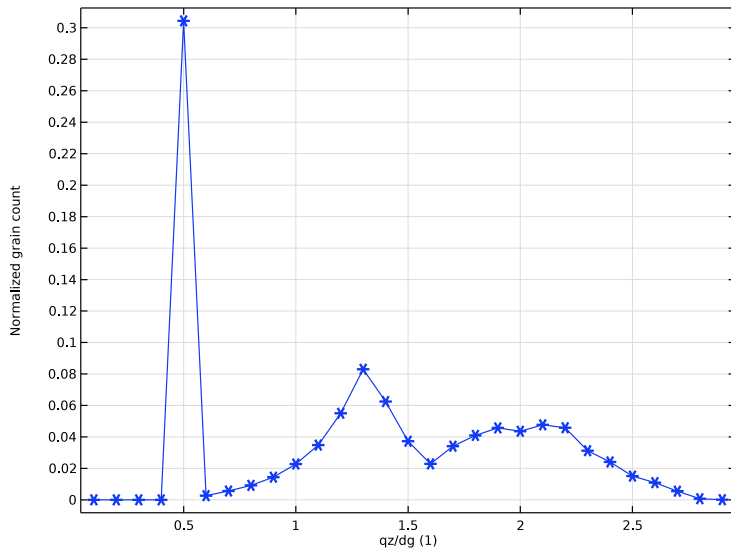

Figure 6: Distribution of grain heights in the powder bed.

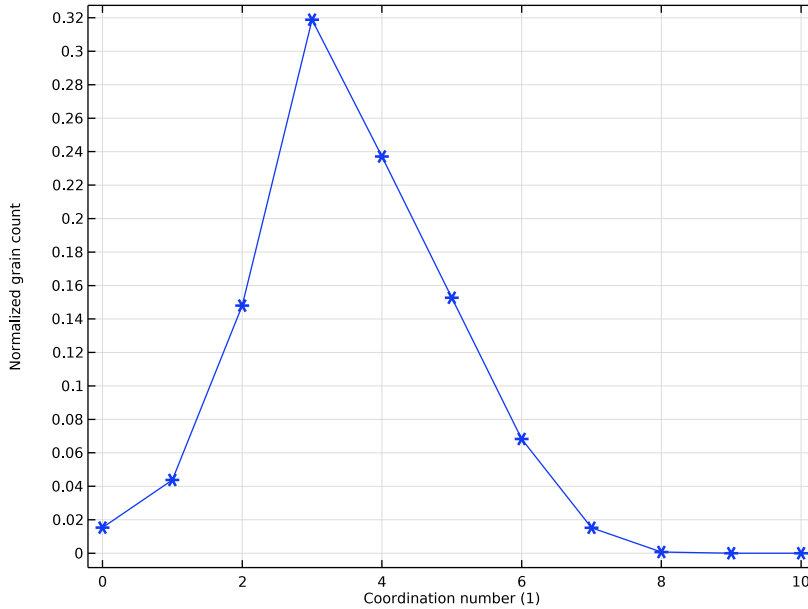

Figure 7: Distribution of grain coordination numbers in the powder bed.

### Reference

I. Y.M. Fouda and A.E. Bayly, “A DEM study of powder spreading in additive layer manufacturing,” *Granular Matter*, vol. 22, no. 1, p. 10, 2020.

---

**Application Library path:** Granular\_Flow\_Module/Transport/powder\_spreading

---

### Modeling Instructions



From the **Main Toolbar** menu, choose **New**.

#### NEW

In the **New** window, click  **Model Wizard**.

#### MODEL WIZARD

**1** In the **Model Wizard** window, click  **3D**.

- 2 In the **Select Physics** tree, select **Fluid Flow > Granular Flow (gran)**.
- 3 Click **Add**.
- 4 Click  **Study**.
- 5 In the **Select Study** tree, select **General Studies > Time Dependent**.
- 6 Click  **Done**.

## GLOBAL DEFINITIONS

### Model Parameters

- 1 In the **Model Builder** window, under **Global Definitions** click **Parameters I**.
- 2 In the **Settings** window for **Parameters**, type Model Parameters in the **Label** text field.
- 3 Locate the **Parameters** section. Click  **Load from File**.
- 4 Browse to the model's Application Libraries folder and double-click the file `powder_spreading_parameters.txt`.

## DEFINITIONS

### Variables I

- 1 In the **Definitions** toolbar, click  **Local Variables**.
- 2 In the **Settings** window for **Variables**, locate the **Variables** section.
- 3 In the table, enter the following settings:

Name	Expression	Unit	Description
roller_disp	roller_v*(t-t_heap)	m	Roller displacement

## GEOMETRY I

### Block I (blk1)

- 1 In the **Geometry** toolbar, click  **Block**.
- 2 In the **Settings** window for **Block**, locate the **Size and Shape** section.
- 3 In the **Width** text field, type `roller_dia+2*roller_gap+5*Lx`.
- 4 In the **Depth** text field, type `Ly`.
- 5 In the **Height** text field, type `Lz`.
- 6 Locate the **Position** section. In the **x** text field, type `-(roller_dia+2*roller_gap)`.

7 Click to expand the **Layers** section. In the table, enter the following settings:

Layer name	Thickness (m)
Layer 1	$\text{roller\_dia}+2*\text{roller\_gap}$
Layer 2	Lx

8 Find the **Layer position** subsection. Select the **Left** checkbox.

9 Clear the **Bottom** checkbox.

#### *Cylinder 1 (cyl1)*

1 In the **Geometry** toolbar, click  **Cylinder**.

2 In the **Settings** window for **Cylinder**, locate the **Size and Shape** section.

3 In the **Radius** text field, type  $\text{roller\_dia}/2$ .

4 In the **Height** text field, type  $L_y$ .

5 Locate the **Position** section. In the **x** text field, type  $-(\text{roller\_dia}/2+\text{roller\_gap})$ .

6 In the **z** text field, type  $\text{roller\_dia}/2+\text{roller\_gap}$ .

7 Locate the **Axis** section. From the **Axis type** list, choose **y-axis**.

8 Click  **Build All Objects**.

9 Click the  **Transparency** button in the **Graphics** toolbar. The geometry should look like [Figure 1](#).

### **GRANULAR FLOW (GRAN)**

#### *Grain Properties 1*

1 In the **Model Builder** window, under **Component 1 (comp1) > Granular Flow (gran)** click **Grain Properties 1**.

2 In the **Settings** window for **Grain Properties**, locate the **Granular Material Properties** section.

3 From the  $\rho_g$  list, choose **User defined**. In the associated text field, type  $\rho$ .

4 From the  $E_g$  list, choose **User defined**. In the associated text field, type  $E$ .

5 From the  $v_g$  list, choose **User defined**. In the associated text field, type  $\rho \text{ois}$ .

6 Locate the **Size** section. In the  $d_g$  text field, type  $d_g$ .

#### *Wall 1*

1 In the **Model Builder** window, click **Wall 1**.

2 In the **Settings** window for **Wall**, locate the **Wall Material Properties** section.

3 From the  $E$  list, choose **User defined**. In the associated text field, type  $E$ .

4 From the  $v$  list, choose **User defined**. In the associated text field, type `pois`.

#### *Contact Between Grains I*

- 1 In the **Model Builder** window, click **Contact Between Grains I**.
- 2 In the **Settings** window for **Contact Between Grains**, locate the **Contact Properties** section.
- 3 In the  $e_n$  text field, type `e`.
- 4 In the  $e_t$  text field, type `e`.
- 5 In the  $\mu_s$  text field, type `mu_s`.
- 6 In the  $\mu_r$  text field, type `mu_r`.
- 7 In the  $\mu_{tw}$  text field, type `mu_tw`.

#### *Contact with Walls I*

- 1 In the **Model Builder** window, click **Contact with Walls I**.
- 2 In the **Settings** window for **Contact with Walls**, locate the **Contact Properties** section.
- 3 In the  $e_n$  text field, type `e`.
- 4 In the  $e_t$  text field, type `e`.
- 5 In the  $\mu_s$  text field, type `mu_s`.
- 6 In the  $\mu_r$  text field, type `mu_r`.
- 7 In the  $\mu_{tw}$  text field, type `mu_tw`.

#### *Release I*

- 1 In the **Physics** toolbar, click  **Domains** and choose **Release**.
- 2 Select Domain 3 only.
- 3 In the **Settings** window for **Release**, locate the **Released Grain Properties** section.
- 4 In the table, enter the following settings:

Released grain properties	Number of grains
Grain Properties I	N

#### *Outlet I*

- 1 In the **Physics** toolbar, click  **Boundaries** and choose **Outlet**.
- 2 Select Boundaries 12 and 17 only.

#### *Roller*

Next, add a **Wall** node to specify the settings for the motion of the roller.

- 1 In the **Physics** toolbar, click  **Boundaries** and choose **Wall**.

- 2 In the **Settings** window for **Wall**, type **Roller** in the **Label** text field.
- 3 Select Boundaries 6, 7, 10, and 11 only.
- 4 Locate the **Wall Material Properties** section. From the *E* list, choose **User defined**. In the associated text field, type **E**.
- 5 From the *v* list, choose **User defined**. In the associated text field, type **pois**.
- 6 Locate the **Wall Movement** section. From the **Wall motion** list, choose **Translation and rotation**.
- 7 Specify the  $dx$  vector as

roller_disp	X
0	Y
0	Z



- 8 In the  $\omega$  text field, type **roller\_om**.
- 9 In the  $\alpha_0$  text field, type **-roller\_om\*t\_heap**. Note that the roller movement will only be activated at the third study which starts at **t\_heap**. Thus it is important to specify the initial angle of rotation appropriately.
- 10 Specify the  $r_{bp}$  vector as

-(roller_dia/2+roller_gap)	X
0	Y
roller_dia/2+roller_gap	Z

- 11 Specify the  $e_{ax}$  vector as

0	X
1	Y
0	Z

#### *Periodic Condition 1*



- 1 In the **Physics** toolbar, click  **Boundaries** and choose **Periodic Condition**.
- 2 Select Boundaries 2, 5, 8, 9, 13, 16, 18, and 21 only.
- 3 Click the  **Transparency** button in the **Graphics** toolbar.

### **STUDY 1: FILLING**

Set up the first study to release the grains into the domain and to simulate the filling of the domain.



- 1 In the **Model Builder** window, click **Study 1**.
- 2 In the **Settings** window for **Study**, type Study 1: Filling in the **Label** text field.

#### *Step 1: Time Dependent*

- 1 In the **Model Builder** window, under **Study 1: Filling** click **Step 1: Time Dependent**.
- 2 In the **Settings** window for **Time Dependent**, locate the **Study Settings** section.
- 3 In the **Output times** text field, type `range(0,t_fill/10,t_fill)`.
- 4 Locate the **Physics and Variables Selection** section. Select the **Modify model configuration for study step** checkbox.
- 5 In the tree, select **Component 1 (comp1) > Granular Flow (gran) > Outlet 1** and **Component 1 (comp1) > Granular Flow (gran) > Roller**.
- 6 Click  **Disable**.
- 7 In the **Study** toolbar, click  **Compute**.



## RESULTS

#### *Grain Positions: Filling*

- 1 In the **Settings** window for **3D Plot Group**, type Grain Positions: Filling in the **Label** text field.
- 2 Click the  **Zoom Extents** button in the **Graphics** toolbar.
- 3 Click the  **Go to Default View** button in the **Graphics** toolbar.

The grain positions at the end of the first study should resemble [Figure 2](#).

#### *Filling*

- 1 In the **Grain Positions: Filling** toolbar, click  **Animation** and choose **Player**.
- 2 In the **Settings** window for **Animation**, type Filling in the **Label** text field.
- 3 Locate the **Frames** section. From the **Frame selection** list, choose **All**.
- 4 Click the  **Play** button in the **Graphics** toolbar.

## ADD STUDY

Next, set up the second study to simulate the heap formation that occurs when the two boundaries of the domain containing the grains are removed.



- 1 In the **Home** toolbar, click  **Add Study** to open the **Add Study** window.
- 2 Go to the **Add Study** window.
- 3 Find the **Studies** subsection. In the **Select Study** tree, select **General Studies > Time Dependent**.

- 4 Click the **Add Study** button in the window toolbar.
- 5 In the **Home** toolbar, click  **Add Study** to close the **Add Study** window.

## STUDY 2: HEAP FORMATION

In the **Settings** window for **Study**, type Study 2: Heap Formation in the **Label** text field.

### Step 1: Time Dependent

- 1 In the **Model Builder** window, under **Study 2: Heap Formation** click **Step 1: Time Dependent**.
- 2 In the **Settings** window for **Time Dependent**, locate the **Study Settings** section.
- 3 In the **Output times** text field, type  $\text{range}(t_{\text{fill}}, (t_{\text{heap}} - t_{\text{fill}}) / 10, t_{\text{heap}})$ .
- 4 Locate the **Physics and Variables Selection** section. Select the **Modify model configuration for study step** checkbox.
- 5 In the tree, select **Component 1 (comp1) > Granular Flow (gran) > Roller**.
- 6 Click  **Disable**.
- 7 Click to expand the **Values of Dependent Variables** section. Find the **Initial values of variables solved for** subsection. From the **Settings** list, choose **User controlled**.
- 8 From the **Method** list, choose **Solution**.
- 9 From the **Study** list, choose **Study 1: Filling, Time Dependent**.
- 10 From the **Time (s)** list, choose **Last**.
- 11 In the **Study** toolbar, click  **Compute**.



## RESULTS

### Grain Positions: Heap Formation

In the **Settings** window for **3D Plot Group**, type Grain Positions: Heap Formation in the **Label** text field.

The grain positions at the end of the second study should resemble [Figure 3](#).

### Heap Formation



- 1 In the **Grain Positions: Heap Formation** toolbar, click  **Animation** and choose **Player**.
- 2 In the **Settings** window for **Animation**, type Heap Formation in the **Label** text field.
- 3 Locate the **Frames** section. From the **Frame selection** list, choose **All**.
- 4 Click the  **Play** button in the **Graphics** toolbar.

## GRANULAR FLOW (GRAN)

Before setting up the final study to simulate the spreading of the grains to form a powder bed due to the motion of the roller, enable the computation of the coordination numbers for the grains.

- 1 In the **Model Builder** window, under **Component 1 (comp1)** click **Granular Flow (gran)**.
- 2 In the **Settings** window for **Granular Flow**, locate the **Additional Variables** section.
- 3 Select the **Compute coordination numbers** checkbox.

## ADD STUDY

- 1 In the **Study** toolbar, click  **Add Study** to open the **Add Study** window.
- 2 Go to the **Add Study** window.
- 3 Find the **Studies** subsection. In the **Select Study** tree, select **General Studies > Time Dependent**.
- 4 Click the **Add Study** button in the window toolbar.
- 5 In the **Study** toolbar, click  **Add Study** to close the **Add Study** window.

## STUDY 3: SPREADING

In the **Settings** window for **Study**, type Study 3: Spreading in the **Label** text field.

### *Step 1: Time Dependent*

- 1 In the **Model Builder** window, under **Study 3: Spreading** click **Step 1: Time Dependent**.
- 2 In the **Settings** window for **Time Dependent**, locate the **Study Settings** section.
- 3 In the **Output times** text field, type range ( $t_{\text{heap}}, 0.1, t_{\text{spread}}$ ).
- 4 Locate the **Values of Dependent Variables** section. Find the **Initial values of variables solved for** subsection. From the **Settings** list, choose **User controlled**.
- 5 From the **Method** list, choose **Solution**.
- 6 From the **Study** list, choose **Study 2: Heap Formation, Time Dependent**.
- 7 In the **Study** toolbar, click  **Compute**.

## RESULTS

### *Grain Positions: Spreading*

- 1 In the **Settings** window for **3D Plot Group**, type Grain Positions: Spreading in the **Label** text field.

Modify the default plot settings to better visualize the roller rotations.

2 In the **Model Builder** window, expand the **Grain Positions: Spreading** node.

#### *Color Expression 1*

1 In the **Model Builder** window, expand the **Results > Grain Positions: Spreading > Grain Positions 1** node, then click **Color Expression 1**.

2 In the **Settings** window for **Color Expression**, locate the **Expression** section.

3 In the **Expression** text field, type `gran.Ng`.

4 In the **Grain Positions: Spreading** toolbar, click  **Plot**.

#### *Surface 1*

1 In the **Model Builder** window, under **Results > Grain Positions: Spreading** click **Surface 1**.

2 In the **Settings** window for **Surface**, locate the **Coloring and Style** section.

3 From the **Coloring** list, choose **Uniform**.

4 From the **Color** list, choose **Gray**.

#### *Selection 1*

1 In the **Model Builder** window, expand the **Surface 1** node, then click **Selection 1**.

2 In the **Settings** window for **Selection**, locate the **Selection** section.

3 Click to select the  **Activate Selection** toggle button.

4 In the list, choose **6** and **11**.

5 Click  **Remove from Selection**.

6 Select Boundaries 7 and 10 only.

#### *Surface 2*

1 In the **Model Builder** window, under **Results > Grain Positions: Spreading** right-click **Surface 1** and choose **Duplicate**.

2 In the **Settings** window for **Surface**, locate the **Coloring and Style** section.

3 From the **Color** list, choose **Yellow**.

#### *Selection 1*

1 In the **Model Builder** window, expand the **Surface 2** node, then click **Selection 1**.

2 In the **Settings** window for **Selection**, locate the **Selection** section.

3 Click to select the  **Activate Selection** toggle button.



4 Click  **Clear Selection**.

5 Select Boundaries 6 and 11 only.

6 In the **Grain Positions: Spreading** toolbar, click  **Plot**.

- 7 Click the  **Zoom Extents** button in the **Graphics** toolbar. The powder bed at the end of the third study should resemble [Figure 4](#).

### *Spreading*



- 1 In the **Grain Positions: Spreading** toolbar, click  **Animation** and choose **Player**.
- 2 In the **Settings** window for **Animation**, type **Spreading** in the **Label** text field.
- 3 Locate the **Frames** section. From the **Frame selection** list, choose **All**.
- 4 Click the  **Play** button in the **Graphics** toolbar.

### *1D Histogram*

Next, a **1D Histogram** of the x-coordinates of the grains is first computed, and the resultant data is used to set up an **Interpolation** function. This function is then used to compute the packing fraction of the grains within the powder bed.

- 1 In the **Results** toolbar, click  **ID Plot Group**.
- 2 In the **Settings** window for **ID Plot Group**, type **1D Histogram** in the **Label** text field.
- 3 Locate the **Data** section. From the **Dataset** list, choose **Grain 3**.
- 4 From the **Time selection** list, choose **Last**.

### *Histogram 1*

- 1 In the **ID Histogram** toolbar, click  **Histogram**.
- 2 In the **Settings** window for **Histogram**, locate the **Expression** section.
- 3 In the **Expression** text field, type `qx`.
- 4 Locate the **Bins** section. From the **Entry method** list, choose **Limits**.
- 5 In the **Limits** text field, type `range(sample_xmin, sample_width, sample_xmax)`.
- 6 Click to expand the **Coloring and Style** section. Find the **Line style** subsection. From the **Line** list, choose **None**.
- 7 Find the **Line markers** subsection. From the **Marker** list, choose **Cycle**.
- 8 In the **ID Histogram** toolbar, click  **Plot**.
- 9 Right-click **Histogram 1** and choose **Copy Plot Data to Table**.

## **DEFINITIONS**

### *Interpolation 1 (int1)*

- 1 In the **Definitions** toolbar, click  **Interpolation**.
- 2 In the **Settings** window for **Interpolation**, locate the **Definition** section.
- 3 From the **Data source** list, choose **Result table**.

- 4 Locate the **Data Column Settings** section. In the **Unit** text field, type m.
- 5 Click  **Create Plot**.

## RESULTS

### *Packing Fraction*

- 1 In the **Settings** window for **ID Plot Group**, click to expand the **Title** section.
- 2 From the **Title type** list, choose **None**.
- 3 In the **Label** text field, type Packing Fraction.
- 4 Locate the **Plot Settings** section. Select the **x-axis label** checkbox.
- 5 Select the **y-axis label** checkbox.
- 6 In the **x-axis label** text field, type  $x$  (m).
- 7 In the **y-axis label** text field, type Packing fraction.



### *Function 1*

- 1 In the **Model Builder** window, expand the **Packing Fraction** node, then click **Function 1**.
- 2 In the **Settings** window for **Function**, locate the **y-Axis Data** section.
- 3 In the **Expression** text field, type  $\text{int1}(x) * \pi / 6 * dg^3 / (\text{sample\_width} * Ly * \text{roller\_gap})$ .
- 4 Locate the **x-Axis Data** section. Clear the **Description** checkbox.
- 5 Locate the **Output** section. From the **Extrapolation** list, choose **None**.
- 6 In the **Packing Fraction** toolbar, click  **Plot**. The plot of the packing fraction in the powder bed as a function of the x-coordinate should resemble [Figure 5](#).



### *Height Distribution*

- 1 In the **Home** toolbar, click  **Add Plot Group** and choose **ID Plot Group**.
- 2 In the **Settings** window for **ID Plot Group**, type Height Distribution in the **Label** text field.
- 3 Locate the **Data** section. From the **Dataset** list, choose **Grain 3**.
- 4 From the **Time selection** list, choose **Last**.
- 5 Locate the **Title** section. From the **Title type** list, choose **None**.
- 6 Locate the **Plot Settings** section.
- 7 Select the **x-axis label** checkbox. In the associated text field, type  $qz / dg$  (1).
- 8 Select the **y-axis label** checkbox. In the associated text field, type Normalized grain count.

### *Histogram 1*

- 1 In the **Height Distribution** toolbar, click  **Histogram**.
- 2 In the **Settings** window for **Histogram**, locate the **Expression** section.
- 3 In the **Expression** text field, type `qz/dg`.
- 4 Locate the **Bins** section. From the **Entry method** list, choose **Limits**.
- 5 In the **Limits** text field, type `range(0.05,0.1,roller_gap/dg)`.
- 6 Locate the **Output** section. From the **Normalization** list, choose **Sum of values**.
- 7 Locate the **Coloring and Style** section. Find the **Line markers** subsection. From the **Marker** list, choose **Cycle**.
- 8 In the **Height Distribution** toolbar, click  **Plot**.

### *Filter 1*

- 1 In the **Height Distribution** toolbar, click  **Filter**.
- 2 In the **Settings** window for **Filter**, locate the **Point Selection** section.
- 3 In the **Logical expression for inclusion** text field, type `qx>=sample_xmin && qx<=sample_xmax`.
- 4 In the **Height Distribution** toolbar, click  **Plot**. The distribution of the heights of the grains should resemble [Figure 6](#).

### *Coordination Number Distribution*

- 1 In the **Model Builder** window, right-click **Height Distribution** and choose **Duplicate**.
- 2 In the **Settings** window for **ID Plot Group**, type **Coordination Number Distribution** in the **Label** text field.
- 3 Locate the **Plot Settings** section. In the **x-axis label** text field, type **Coordination number (1)**.

### *Histogram 1*

- 1 In the **Model Builder** window, expand the **Coordination Number Distribution** node, then click **Histogram 1**.
- 2 In the **Settings** window for **Histogram**, locate the **Expression** section.
- 3 In the **Expression** text field, type `gran.Ng`.
- 4 Locate the **Bins** section. In the **Limits** text field, type `range(-0.5,1.0,10.5)`.
- 5 In the **Coordination Number Distribution** toolbar, click  **Plot**. The distribution of the grain coordination numbers should resemble [Figure 7](#).