



Model created in COMSOL Multiphysics 6.4

# Hopper Flow

## *Introduction*

---

Hoppers are industrial containers that are typically used to store and discharge granular materials. They are typically funnel shaped with a cylindrical top and a conical bottom that contains an outlet that can be used to discharge the stored material when needed at a controlled rate. Hoppers find vast uses in many industries, including agriculture, food processing, manufacturing, mining, and construction. The material discharge from a hopper often exhibits some combination of two flow patterns: mass flow and funnel flow.

Mass-flow patterns are characterized by all the material flowing simultaneously out of the hopper. They also typically follow the first-in first-out pattern, whereby the material at the bottom of the hopper tends to discharge first at a quicker rate before the higher layers. The layers tend not to mix during the discharge and are therefore preferable in industries such as agriculture where the oldest grains tend to be at the bottom of the hopper.

On the other hand, funnel flow patterns are characterized by a discharge where only a portion of the material discharges at any given time. The layers tend to mix during the discharge and it is possible for some material to stick to the walls. These hoppers have the advantage of having a smaller footprint and thus may be preferred in applications where space is a constraint.

The shape of the hopper can have a significant influence on the resulting flow patterns. In this model, two hopper designs are considered. The overall height of the hopper is held constant and the conical angle is varied to alter the shape of the hopper to demonstrate the two flow patterns.

## *Model Definition*

---

The geometry of a hopper is simple and contains a cylinder attached to a conical compartment at the bottom. The grains enter the hopper through an inlet at the top of the cylinder. When material discharge is desired, the grains can exit through an outlet at the bottom of the cone. The radius of the cylinder in this model is 10 cm, and the smaller radius of the cone (outlet) is 4 cm. The total height of the hopper is set fixed at 30 cm. The overall shape of the hopper is controlled by the conical angle. In this model, two hopper designs are considered with the conical angles of 15 and 75 degrees. The geometry of the hopper with the conical angle of 15 degrees is shown in [Figure 1](#).

For each hopper design, a total of 150 grains, each having a diameter of 10 mm are released at the inlet boundary every 20 ms up to 0.58 s, thus leading to a total of 4500 grains. The grains are allowed to settle under gravity for the first 1.0 s, after which the outlet is opened to allow the discharge of the stored material for a total of 4.0 s.

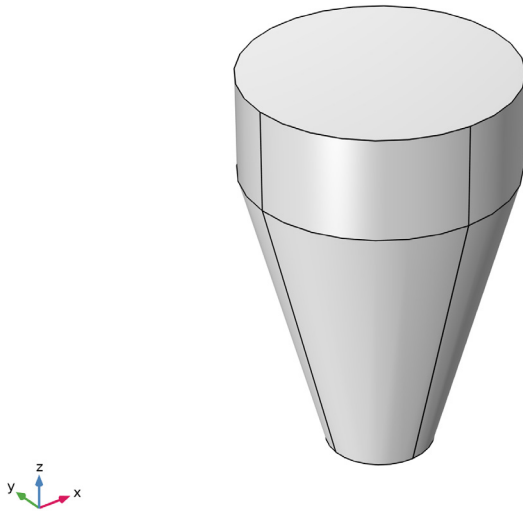

*Figure 1: Model geometry with small conical angle of 15 degrees.*

### *Notes on the COMSOL Implementation*

---

For each hopper design, the model is solved using two studies. In the first study, the grains are released into the hopper using the **Inlet** feature and are allowed to settle under gravity. In the second study, the degrees of freedom from the first study are used to initialize the grains, and the **Outlet** feature is used to simulate the material discharge. Once the grains exit the hopper, the grains flow freely in to the void which can severely affect the performance of the simulation. Therefore, a **Bounding Box** feature is used to remove these grains from the simulation.

The model geometry is parameterized and the shape of the hopper is controlled by the conical angle. Therefore, a **Parametric Sweep** feature is used to simulate the storage and discharge in both the hopper designs.

### *Results and Discussion*

---

[Figure 2](#) and [Figure 3](#) show the grain positions at the end of the first study for the two hopper designs. The grains are colored by their release time, which allows visualization of the various layers.

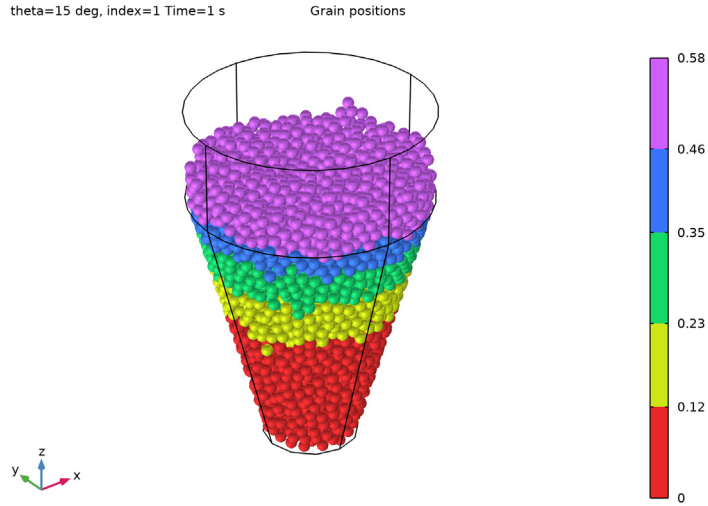

*Figure 2: Hopper with the small conical angle (15 degrees) filled with grains.*

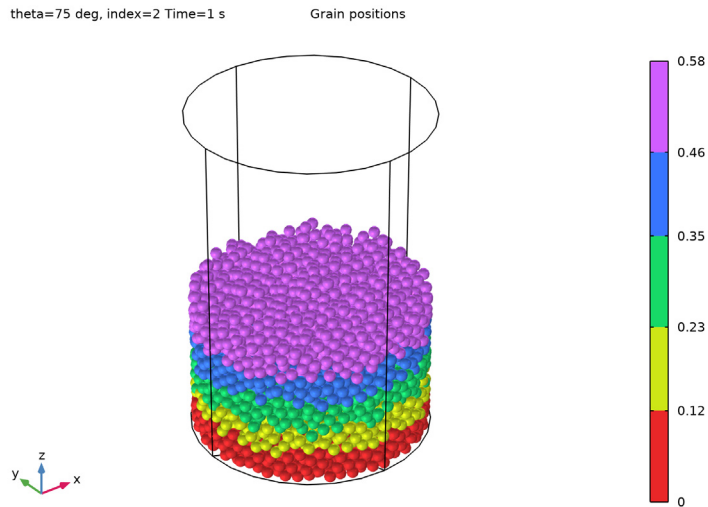

*Figure 3: Hopper with the large conical angle (75 degrees) filled with grains.*

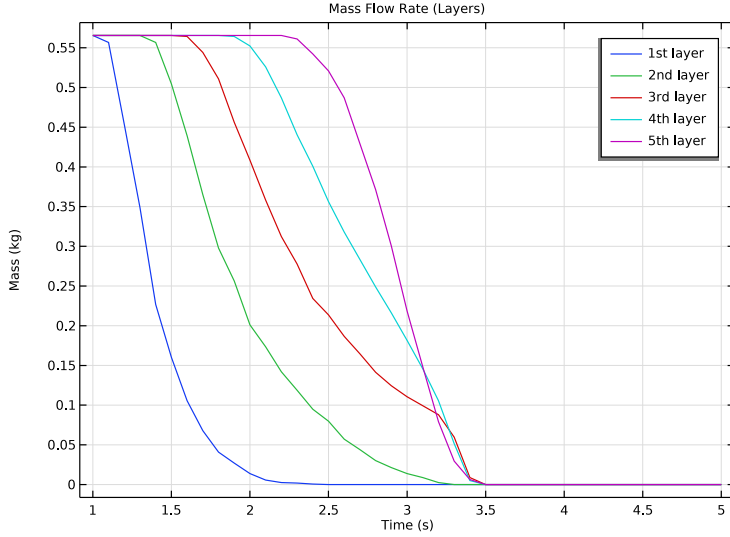

Figure 4: Mass of each layer in the hopper with small conical angle (15 degrees).

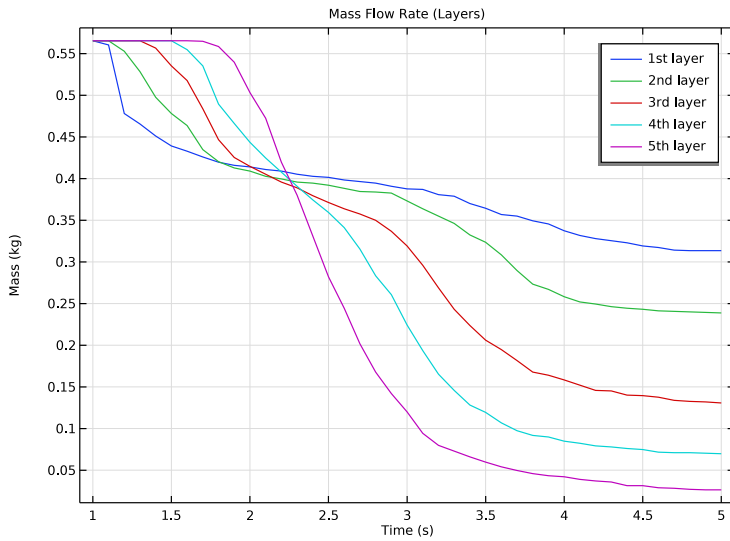
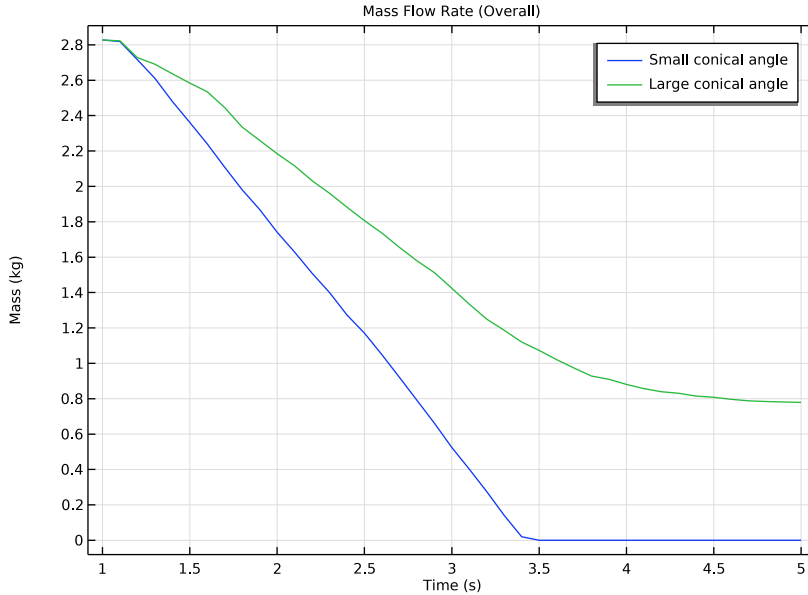

Figure 5: Mass of each layer in the hopper with large conical angle (75 degrees).



*Figure 6: Effect of the hopper design on the overall mass of grains in the hopper.*

As the material discharges, the mass of each layer remaining in the hopper is plotted in [Figure 4](#) and [Figure 5](#). The overall material is divided into five layers based on their release time, with all the grains released in each interval of 0.12 s belonging to one layer. At the beginning of the discharge, the first layer is situated at the bottom and the fifth layer lies at the top. It is evident that the discharge patterns are very different in the two hoppers.

The discharge in the first hopper (15 degrees) exhibits First-In First-Out behavior whereby each layer discharges based on its height (or age) in the hopper. This is typical of a mass-flow pattern, where the mixing of layers is minimal in the discharge. On the other hand, the second hopper design exhibits a typical funnel-flow pattern, where the layers tend to mix together. It can also be seen that the topmost layer discharges first, while the bottom layer has a very slow discharge rate.

[Figure 6](#) compares the overall mass of all the layers combined remaining in the hopper for the two designs. The hopper with the small conical angle, representing mass flow, clearly has a much larger discharge rate compared to the funnel flow.

---

**Application Library path:** Granular\_Flow\_Module/  
Flow\_and\_Material\_Characterization/hopper\_flow

---

### *Modeling Instructions*



---

From the **Main Toolbar** menu, choose **New**.

#### **NEW**

In the **New** window, click  **Model Wizard**.

#### **MODEL WIZARD**

- 1 In the **Model Wizard** window, click  **3D**.
- 2 In the **Select Physics** tree, select **Fluid Flow > Granular Flow (gran)**.
- 3 Click **Add**.
- 4 Click  **Study**.
- 5 In the **Select Study** tree, select **General Studies > Time Dependent**.
- 6 Click  **Done**.

#### **GLOBAL DEFINITIONS**

##### *Parameters 1*

- 1 In the **Model Builder** window, under **Global Definitions** click **Parameters 1**.
- 2 In the **Settings** window for **Parameters**, locate the **Parameters** section.
- 3 Click  **Load from File**.
- 4 Browse to the model's Application Libraries folder and double-click the file `hopper_flow_parameters.txt`.

#### **GEOMETRY 1**

##### *Cylinder 1 (cyl1)*

- 1 In the **Geometry** toolbar, click  **Cylinder**.
- 2 In the **Settings** window for **Cylinder**, locate the **Size and Shape** section.
- 3 In the **Radius** text field, type `R_in1`.
- 4 In the **Height** text field, type `H_cyl`.

5 Locate the **Position** section. In the **z** text field, type H\_cone.



#### *Cone 1 (cone1)*

- 1 In the **Geometry** toolbar, click  **Cone**.
- 2 In the **Settings** window for **Cone**, locate the **Size and Shape** section.
- 3 In the **Bottom radius** text field, type R\_out.
- 4 In the **Height** text field, type H\_cone.
- 5 In the **Top radius** text field, type R\_in1.

#### *Union 1 (un1)*





- 1 In the **Geometry** toolbar, click  **Booleans and Partitions** and choose **Union**.
- 2 Click in the **Graphics** window and then press Ctrl+A to select both objects.
- 3 In the **Settings** window for **Union**, locate the **Union** section.
- 4 Clear the **Keep interior boundaries** checkbox.

#### *Form Union (fin)*

- 1 In the **Geometry** toolbar, click  **Build All**.
- 2 Click the  **Show Grid** button in the **Graphics** toolbar.
- 3 Click the  **Zoom Extents** button in the **Graphics** toolbar. The geometry should look like [Figure 1](#).

## **MATERIALS**

#### *Grains*

- 1 In the **Materials** toolbar, click  **Blank Material**.
- 2 In the **Settings** window for **Material**, type Grains in the **Label** text field.
- 3 Click to expand the **Material Properties** section. In the **Material properties** tree, select **Basic Properties > Density**.
- 4 Click  **Add to Material**.
- 5 In the **Material properties** tree, select **Basic Properties > Poisson's Ratio**.
- 6 Click  **Add to Material**.
- 7 In the **Material properties** tree, select **Basic Properties > Young's Modulus**.
- 8 Click  **Add to Material**.

9 Locate the **Material Contents** section. In the table, enter the following settings:

Property	Variable	Value	Unit	Property group
Density	rho	rhog	kg/m <sup>3</sup>	Basic
Poisson's ratio	nu	pois	l	Basic
Young's modulus	E	Eg	Pa	Basic

#### Walls

- 1 In the **Materials** toolbar, click  **Blank Material**.
- 2 In the **Settings** window for **Material**, type Walls in the **Label** text field.
- 3 Locate the **Geometric Entity Selection** section. From the **Geometric entity level** list, choose **Boundary**.
- 4 From the **Selection** list, choose **All boundaries**.
- 5 Locate the **Material Contents** section. In the table, enter the following settings:

Property	Variable	Value	Unit	Property group
Young's modulus	E	2.5*Eg	Pa	Basic
Poisson's ratio	nu	pois	l	Basic

## GRANULAR FLOW (GRAN)

### Grain Properties I

- 1 In the **Model Builder** window, under **Component 1 (comp1) > Granular Flow (gran)** click **Grain Properties 1**.
- 2 In the **Settings** window for **Grain Properties**, locate the **Granular Material Properties** section.
- 3 From the **Granular material** list, choose **Grains (mat1)**.
- 4 Locate the **Size** section. In the  $d_g$  text field, type dg.

### Wall I

In the **Model Builder** window, click **Wall 1**.

### Force Accumulator I

In the **Physics** toolbar, click  **Attributes** and choose **Force Accumulator**.

### Contact Between Grains I

- 1 In the **Model Builder** window, under **Component 1 (comp1) > Granular Flow (gran)** click **Contact Between Grains 1**.

- 2 In the **Settings** window for **Contact Between Grains**, locate the **Contact Properties** section.
- 3 In the  $e_n$  text field, type  $e_n$ .
- 4 In the  $e_t$  text field, type  $e_t$ .
- 5 In the  $\mu_s$  text field, type  $\mu_s$ .
- 6 In the  $\mu_r$  text field, type  $\mu_r$ .
- 7 In the  $\mu_{tw}$  text field, type  $\mu_{tw}$ .

*Contact with Walls I*

- 1 In the **Model Builder** window, click **Contact with Walls I**.
- 2 In the **Settings** window for **Contact with Walls**, locate the **Contact Properties** section.
- 3 In the  $e_n$  text field, type  $e_n$ .
- 4 In the  $e_t$  text field, type  $e_t$ .
- 5 In the  $\mu_s$  text field, type  $\mu_s$ .
- 6 In the  $\mu_r$  text field, type  $\mu_r$ .
- 7 In the  $\mu_{tw}$  text field, type  $\mu_{tw}$ .

*Inlet I*

- 1 In the **Physics** toolbar, click  **Boundaries** and choose **Inlet**.
- 2 Select Boundary 5 only.
- 3 In the **Settings** window for **Inlet**, locate the **Release Times** section.
- 4 In the **Release times** text field, type  $\text{range}(0, \text{re1\_freq}, 29 * \text{re1\_freq})$ .
- 5 Locate the **Initial Values** section. Specify the  $\mathbf{v}_0$  vector as

-0.5	z
------	---

- 6 Locate the **Released Grain Properties** section. In the table, enter the following settings:

Released grain properties	Number of grains
Grain Properties I	150

- 7 Locate the **Advanced Settings** section. In the **Number of release attempts per grain** text field, type 50 to increase the chances of all the grains being released at each release time.

*Outlet I*

- 1 In the **Physics** toolbar, click  **Boundaries** and choose **Outlet**.
- 2 Select Boundary 6 only.

### *Bounding Box 1*

- 1 In the **Physics** toolbar, click  **Global** and choose **Bounding Box**.
- 2 In the **Settings** window for **Bounding Box**, locate the **Settings** section.
- 3 In the **x minimum** text field, type  $-R_{in1}$ .
- 4 In the **x maximum** text field, type  $R_{in1}$ .
- 5 In the **y minimum** text field, type  $-R_{in1}$ .
- 6 In the **y maximum** text field, type  $R_{in1}$ .
- 7 In the **z minimum** text field, type  $-5 \cdot dg$ .
- 8 In the **z maximum** text field, type  $H_{tot} \cdot 1.05$ .



### **STUDY 1: FILLING**

- 1 In the **Model Builder** window, click **Study 1**.
- 2 In the **Settings** window for **Study**, type Study 1: Filling in the **Label** text field.

### *Step 1: Time Dependent*

- 1 In the **Model Builder** window, under **Study 1: Filling** click **Step 1: Time Dependent**.
- 2 In the **Settings** window for **Time Dependent**, locate the **Study Settings** section.
- 3 In the **Output times** text field, type  $\text{range}(0, \text{rel\_freq}, \text{t\_fill})$ .
- 4 Locate the **Physics and Variables Selection** section. Select the **Modify model configuration for study step** checkbox.
- 5 In the tree, select **Component 1 (comp1) > Granular Flow (gran) > Outlet 1** and **Component 1 (comp1) > Granular Flow (gran) > Bounding Box 1**.
- 6 Click  **Disable**.

### *Parametric Sweep*

- 1 In the **Study** toolbar, click  **Parametric Sweep**.
- 2 In the **Settings** window for **Parametric Sweep**, locate the **Study Settings** section.
- 3 Click  **Add**.
- 4 In the table, enter the following settings:

Parameter name	Parameter value list	Parameter unit
theta (Cone angle)	15 75	deg

- 5 Click  **Add**.

6 In the table, enter the following settings:

Parameter name	Parameter value list	Parameter unit
index (Sweep index)	1 2	

7 In the **Study** toolbar, click  **Compute**.

## RESULTS

### *Grain Positions: Filling*

- 1 In the **Settings** window for **3D Plot Group**, type Grain Positions: Filling in the **Label** text field.
- 2 Locate the **Data** section. From the **Parameter value (theta (deg),index)** list, choose **1: theta=15 deg, index=1**.
- 3 In the **Model Builder** window, expand the **Grain Positions: Filling** node.

### *Color Expression 1*

- 1 In the **Model Builder** window, expand the **Results > Grain Positions: Filling > Grain Positions 1** node, then click **Color Expression 1**.
- 2 In the **Settings** window for **Color Expression**, locate the **Expression** section.
- 3 In the **Expression** text field, type `gran.rti`.
- 4 Locate the **Coloring and Style** section. From the **Color table** list, choose **Cyclic**.
- 5 From the **Color table type** list, choose **Discrete**.
- 6 In the **Number of bands** text field, type 5. The discrete color table with five bands helps in visualizing the grains in the hopper as five distinct layers.
- 7 In the **Grain Positions: Filling** toolbar, click  **Plot**.

The hopper with the small conical angle filled with grains should resemble [Figure 2](#).



### *Grain Positions: Filling*

- 1 In the **Model Builder** window, under **Results** click **Grain Positions: Filling**.
- 2 In the **Settings** window for **3D Plot Group**, locate the **Data** section.
- 3 From the **Parameter value (theta (deg),index)** list, choose **2: theta=75 deg, index=2**.
- 4 In the **Grain Positions: Filling** toolbar, click  **Plot**.

The hopper with the large conical angle filled with grains should resemble [Figure 3](#).

### *Filling*

- 1 In the **Grain Positions: Filling** toolbar, click  **Animation** and choose **Player**.

- 2 In the **Settings** window for **Animation**, type Filling in the **Label** text field.
- 3 Locate the **Frames** section. From the **Frame selection** list, choose **All**.
- 4 Click the  **Play** button in the **Graphics** toolbar. This plays the animation for the filling in the hopper with the small conical angle.
- 5 Locate the **Animation Editing** section. From the **Parameter value (theta (deg),index)** list, choose **2: theta=75 deg, index=2**.
- 6 Click the  **Play** button in the **Graphics** toolbar. This plays the animation for the filling in the hopper with the large conical angle.



*Pressure on The Walls*

- 1 In the **Results** toolbar, click  **3D Plot Group**.
- 2 In the **Settings** window for **3D Plot Group**, type Pressure on The Walls in the **Label** text field.
- 3 Locate the **Data** section. From the **Dataset** list, choose **Grain 1**.
- 4 From the **Parameter value (theta (deg),index)** list, choose **1: theta=15 deg, index=1**.



*Surface 1*

- 1 In the **Pressure on The Walls** toolbar, click  **Surface**.
- 2 In the **Settings** window for **Surface**, locate the **Expression** section.
- 3 In the **Expression** text field, type `gran.wp1.facc1.wf/gran.wp1.facc1.meshVol`.
- 4 Locate the **Coloring and Style** section. From the **Color table** list, choose **PrismDark**.

*Pressure on The Walls*

- 1 In the **Model Builder** window, right-click **Filling** and choose **Duplicate**.
- 2 In the **Settings** window for **Animation**, type Pressure on The Walls in the **Label** text field.
- 3 Locate the **Scene** section. From the **Subject** list, choose **Pressure on The Walls**.
- 4 Locate the **Animation Editing** section. From the **Parameter value (theta (deg),index)** list, choose **1: theta=15 deg, index=1**.
- 5 Click the  **Play** button in the **Graphics** toolbar. This plays the animation of the wall pressures in the hopper with the small conical angle.
- 6 From the **Parameter value (theta (deg),index)** list, choose **2: theta=75 deg, index=2**.
- 7 Click the  **Play** button in the **Graphics** toolbar. This plays the animation of the wall pressures in the hopper with the large conical angle.

## ADD STUDY

- 1 In the **Home** toolbar, click  **Add Study** to open the **Add Study** window.
- 2 Go to the **Add Study** window.
- 3 Find the **Studies** subsection. In the **Select Study** tree, select **General Studies > Time Dependent**.
- 4 Click the **Add Study** button in the window toolbar.
- 5 In the **Home** toolbar, click  **Add Study** to close the **Add Study** window.

## STUDY 2: EMPTYING

In the **Settings** window for **Study**, type **Study 2: Emptying** in the **Label** text field.

### *Step 1: Time Dependent*

- 1 In the **Model Builder** window, under **Study 2: Emptying** click **Step 1: Time Dependent**.
- 2 In the **Settings** window for **Time Dependent**, locate the **Study Settings** section.
- 3 In the **Output times** text field, type `range(t_fill,0.1,t_fill+t_empty)`.
- 4 Click to expand the **Values of Dependent Variables** section. Find the **Initial values of variables solved for** subsection. From the **Settings** list, choose **User controlled**.
- 5 From the **Method** list, choose **Solution**.
- 6 From the **Study** list, choose **Study 1: Filling, Time Dependent**.
- 7 From the **Solution** list, choose **Parametric Solutions 1 (sol2)**.
- 8 From the **Use** list, choose **Manual**.
- 9 In the **Index** text field, type `index`.

### *Parametric Sweep*

- 1 In the **Study** toolbar, click  **Parametric Sweep**.
- 2 In the **Settings** window for **Parametric Sweep**, locate the **Study Settings** section.
- 3 Click **+ Add**.
- 4 In the table, enter the following settings:

Parameter name	Parameter value list	Parameter unit
theta (Cone angle)	15 75	deg

- 5 Click **+ Add**.

6 In the table, enter the following settings:

Parameter name	Parameter value list	Parameter unit
index (Sweep index)	1 2	

7 In the **Study** toolbar, click  **Compute**.

## RESULTS

### *Grain Positions: Emptying*

- 1 In the **Settings** window for **3D Plot Group**, type Grain Positions: Emptying in the **Label** text field.
- 2 Locate the **Data** section. From the **Parameter value (theta (deg),index)** list, choose **I: theta=15 deg, index=1**.
- 3 In the **Model Builder** window, expand the **Grain Positions: Emptying** node.



### *Color Expression 1*

- 1 In the **Model Builder** window, expand the **Results > Grain Positions: Emptying > Grain Positions 1** node, then click **Color Expression 1**.
- 2 In the **Settings** window for **Color Expression**, locate the **Expression** section.
- 3 In the **Expression** text field, type `gran.rti`.
- 4 Locate the **Coloring and Style** section. From the **Color table** list, choose **Cyclic**.
- 5 From the **Color table type** list, choose **Discrete**.
- 6 In the **Number of bands** text field, type 5.

### *Grain Positions 1*

In the **Model Builder** window, click **Grain Positions 1**.



### *Filter 1*

- 1 In the **Grain Positions: Emptying** toolbar, click  **Filter**.
- 2 In the **Settings** window for **Filter**, locate the **Grain Selection** section.
- 3 From the **Grains to include** list, choose **Logical expression**.
- 4 In the **Logical expression for inclusion** text field, type `qy>=0`.
- 5 Click the  **Go to XZ View** button in the **Graphics** toolbar.

### *Grain Positions: Emptying*

In the **Model Builder** window, under **Results** click **Grain Positions: Emptying**.

### Emptying

- 1 In the **Grain Positions: Emptying** toolbar, click  **Animation** and choose **Player**.
- 2 In the **Settings** window for **Animation**, type Emptying in the **Label** text field.
- 3 Locate the **Frames** section. From the **Frame selection** list, choose **All**.
- 4 Click the  **Play** button in the **Graphics** toolbar. This plays the animation for the emptying in the hopper with the small conical angle.
- 5 Locate the **Animation Editing** section. From the **Parameter value (theta (deg),index)** list, choose **2: theta=75 deg, index=2**.
- 6 Click the  **Play** button in the **Graphics** toolbar. This plays the animation for the emptying in the hopper with the large conical angle.

### Mass Flow Rate (Layers)

- 1 In the **Results** toolbar, click  **ID Plot Group**.
- 2 In the **Settings** window for **ID Plot Group**, type Mass Flow Rate (Layers) in the **Label** text field.
- 3 Locate the **Data** section. From the **Dataset** list, choose **Grain 2**.
- 4 From the **Parameter selection (theta, index)** list, choose **From list**.
- 5 In the **Parameter values (theta (deg),index)** list box, select **1: theta=15 deg, index=1**.
- 6 Click to expand the **Title** section. From the **Title type** list, choose **Label**.
- 7 Locate the **Plot Settings** section.
- 8 Select the **x-axis label** checkbox. In the associated text field, type Time (s).
- 9 Select the **y-axis label** checkbox. In the associated text field, type Mass (kg).

### Grain 1

- 1 In the **Mass Flow Rate (Layers)** toolbar, click  **More Plots** and choose **Grain**.
- 2 In the **Settings** window for **Grain**, locate the **y-Axis Data** section.
- 3 In the **Expression** text field, type `particleexists*gran.mg`.
- 4 Select the **Description** checkbox. In the associated text field, type 1st layer.
- 5 Click to expand the **Legends** section. Select the **Show legends** checkbox.
- 6 Find the **Include** subsection. Clear the **Solution** checkbox.

### Filter 1

- 1 In the **Mass Flow Rate (Layers)** toolbar, click  **Filter**.
- 2 In the **Settings** window for **Filter**, locate the **Grain Selection** section.
- 3 From the **Grains to include** list, choose **Logical expression**.

4 In the **Logical expression for inclusion** text field, type `gran.rti>=0 && gran.rti<6*rel_freq`.

5 In the **Mass Flow Rate (Layers)** toolbar, click  **Plot**.

#### *Grain 2*

1 In the **Model Builder** window, under **Results > Mass Flow Rate (Layers)** right-click **Grain 1** and choose **Duplicate**.

2 In the **Settings** window for **Grain**, locate the **y-Axis Data** section.

3 In the **Description** text field, type 2nd layer.

#### *Filter 1*

1 In the **Model Builder** window, expand the **Grain 2** node, then click **Filter 1**.

2 In the **Settings** window for **Filter**, locate the **Grain Selection** section.

3 In the **Logical expression for inclusion** text field, type `gran.rti>=6*rel_freq && gran.rti<12*rel_freq`.

#### *Grain 3*

1 In the **Model Builder** window, under **Results > Mass Flow Rate (Layers)** right-click **Grain 2** and choose **Duplicate**.

2 In the **Settings** window for **Grain**, locate the **y-Axis Data** section.

3 In the **Description** text field, type 3rd layer.

#### *Filter 1*

1 In the **Model Builder** window, expand the **Grain 3** node, then click **Filter 1**.

2 In the **Settings** window for **Filter**, locate the **Grain Selection** section.

3 In the **Logical expression for inclusion** text field, type `gran.rti>=12*rel_freq && gran.rti<18*rel_freq`.

#### *Grain 4*

1 In the **Model Builder** window, under **Results > Mass Flow Rate (Layers)** right-click **Grain 3** and choose **Duplicate**.

2 In the **Settings** window for **Grain**, locate the **y-Axis Data** section.

3 In the **Description** text field, type 4th layer.

#### *Filter 1*

1 In the **Model Builder** window, expand the **Grain 4** node, then click **Filter 1**.

2 In the **Settings** window for **Filter**, locate the **Grain Selection** section.

- 3 In the **Logical expression for inclusion** text field, type `gran.rti>=18*rel_freq && gran.rti<24*rel_freq`.

#### *Grain 5*

- 1 In the **Model Builder** window, under **Results > Mass Flow Rate (Layers)** right-click **Grain 4** and choose **Duplicate**.
- 2 In the **Settings** window for **Grain**, locate the **y-Axis Data** section.
- 3 In the **Description** text field, type 5th layer.

#### *Filter 1*

- 1 In the **Model Builder** window, expand the **Grain 5** node, then click **Filter 1**.
- 2 In the **Settings** window for **Filter**, locate the **Grain Selection** section.
- 3 In the **Logical expression for inclusion** text field, type `gran.rti>=24*rel_freq && gran.rti<30*rel_freq`.
- 4 In the **Mass Flow Rate (Layers)** toolbar, click  **Plot**.

The mass of each layer of grains as a function of time in the hopper with the small conical angle should resemble [Figure 4](#).

#### *Mass Flow Rate (Layers)*

- 1 In the **Model Builder** window, under **Results** click **Mass Flow Rate (Layers)**.
- 2 In the **Settings** window for **ID Plot Group**, locate the **Data** section.
- 3 In the **Parameter values (theta (deg),index)** list box, select **2: theta=75 deg, index=2**.
- 4 In the **Mass Flow Rate (Layers)** toolbar, click  **Plot**.

The mass of each layer of grains as a function of time in the hopper with the large conical angle should resemble [Figure 5](#).

#### *Mass Flow Rate (Overall)*

- 1 In the **Results** toolbar, click  **ID Plot Group**.
- 2 In the **Settings** window for **ID Plot Group**, type Mass Flow Rate (Overall) in the **Label** text field.
- 3 Locate the **Data** section. From the **Dataset** list, choose **Grain 2**.
- 4 Locate the **Title** section. From the **Title type** list, choose **Label**.
- 5 Locate the **Plot Settings** section.
- 6 Select the **x-axis label** checkbox. In the associated text field, type Time (s).
- 7 Select the **y-axis label** checkbox. In the associated text field, type Mass (kg).

### Grain 1

- 1 In the **Mass Flow Rate (Overall)** toolbar, click  **More Plots** and choose **Grain**.
- 2 In the **Settings** window for **Grain**, locate the **y-Axis Data** section.
- 3 In the **Expression** text field, type `particleexists*gran.mg`.
- 4 Locate the **Legends** section. Select the **Show legends** checkbox.
- 5 From the **Legends** list, choose **Manual**.
- 6 In the table, enter the following settings:

---

**Legends**

---

Small conical angle

Large conical angle

---

- 7 In the **Mass Flow Rate (Overall)** toolbar, click  **Plot**.

The overall mass of the grains in both the hopper designs should resemble [Figure 6](#).