



Model created in COMSOL Multiphysics 6.4

Concrete Beam with Reinforcement Bars

Introduction

Concrete structures almost always contain reinforcement in the shape of steel bars (*rebars*). In COMSOL Multiphysics, individual rebars can be modeled either by adding a Truss interface to the Solid Mechanics interface used for the concrete or using the Fiber subfeature to model their global effects. The solid mesh for the concrete and the mesh for the rebars can be independent of each other, since the displacements are mapped from within the solid onto the rebars at a certain position.

Model Definition

This example shows how to include steel reinforcement that is much smaller than the geometrical dimensions of the concrete structure. The truss interface is used to model the steel reinforcements instead of a 3D solid. Modeling them as solids would need excessively small elements and would lead to an unnecessarily long solution time.

The geometry of the concrete beam is given in [Figure 1](#).

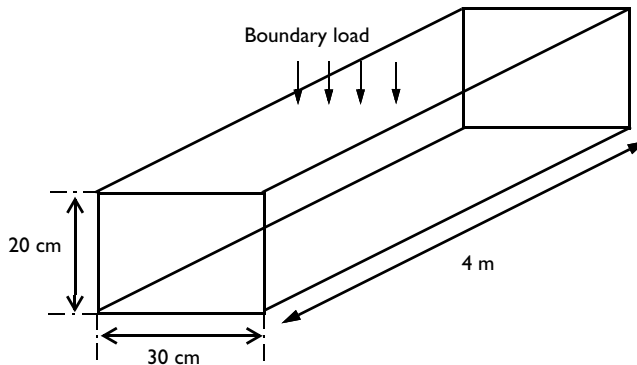

Figure 1: The concrete beam is 30 cm in width, 20 cm in height, and 4 meters in length. Due to symmetries, only a quarter of the beam is modeled.

In the example, most dimensions such as height, width, and length of the concrete structure are parameterized. The number of reinforcement layers is also given by a parameter, and the number of rebars per layer is calculated from the spacing in width dimensions and the minimal distance from the lateral faces of the beam. In this example,

six steel bars, 10 mm in diameter, are placed in four parallel layers along the concrete beam.

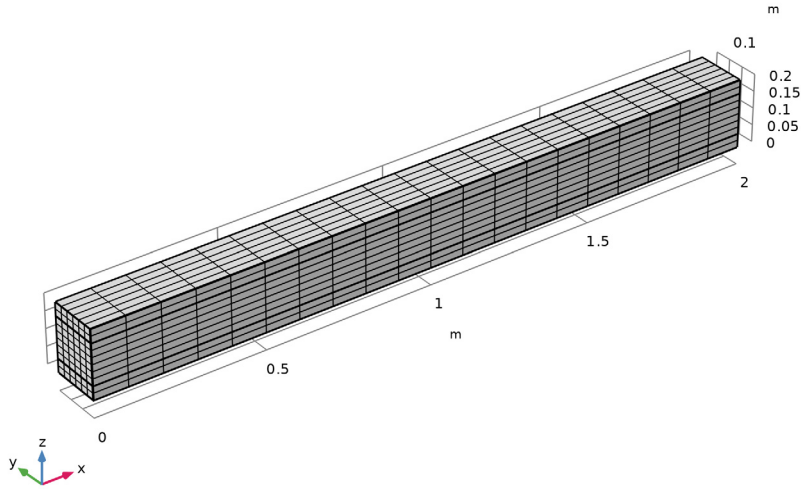

Figure 2: A mapped mesh of 6 by 6 elements is swept through the length of the concrete beam. One hundred elements are used for each reinforcement bar.

The beam is simply supported. Here, this is realized by adding a rigid connector with appropriate constraints to one of the end boundaries.

The beam is subjected to a uniform distributed load on the top. The peak load is 50 kN/m^2 , which corresponds to a line load of 15 kN/m .

Five different variants of modeling are compared:

- Elastic beam without rebars
- Elastic beam with elastoplastic rebars
- Ottosen model for the concrete and elastoplastic rebars
- Mazars damage model for the concrete and elastoplastic rebars
- Elastic beam with distributed fibers

OTTOSEN MODEL

In the Ottosen model, the following parameters are used:

- Uniaxial tensile strength, $\sigma_c = 20$ MPa
- Parameter $a = 1.3$
- Parameter $b = 3.2$
- Size factor $k_1 = 11.8$
- Shape factor $k_2 = 0.98$

With these data, the tensile strength implicitly is about 2 MPa.

MAZARS DAMAGE MODEL

The Mazars damage model accounts for the characteristics of concrete in both tension and compression, where it can describe tensile cracking and the typical stress-strain curve of concrete in compression. To better reflect the failure in multiaxial states of compression, the equivalent strain is defined using the **Modified Mazars** option.

The tensile behavior of the concrete is controlled by the tensile damage evolution law, here set to its default value: **Exponential**. The tensile strength is set to 2 MPa. Also the fracture energy is needed, $G_{ft} = 220$ J/m². To avoid mesh dependence of the results when tensile cracking is considered, a regularization is needed. The crack band method, which is based on information about the finite-element discretization, is used. Although not necessary, it is recommended to use a linear displacement field when the crack band method is used. In this case, a finer mesh is used to compensate for the low-order shape functions.

The compressive behavior of the concrete is described by the compressive damage evolution law, here set to its default value: **Mazars function**. This function can describe the highly nonlinear stress-strain curve of concrete in compression. The parameters are set to $\epsilon_{0c} = 10^{-4}$ and $A_c = 1.12$. Note that the parameter B_c can be calculated using the default expression, which ensures that the stress-strain curve has a continuous slope.

Results and Discussion

Five different studies were done. In the first study, the concrete beam is modeled as an isotropic elastic material without reinforcement. The second study adds the rebars, and the third study includes the effect of plastic deformation in the concrete, modeled using the Ottosen criterion. The fourth study uses a damage model according to Mazars' theory. The fifth study uses the same setup as the second study but replace the rebars with a

continuous fiber distribution. Figure 3 shows the comparison for the vertical displacement of the five studies.

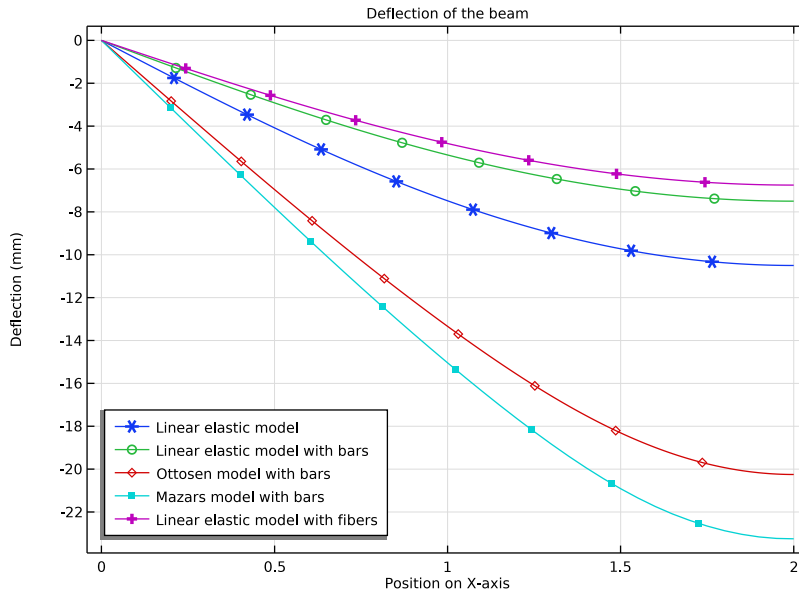

Figure 3: Deflection along the top surface of the beam due to the external load.

The simulations show how force is transferred from the concrete beam to its steel rebars. Figure 4 shows equivalent stresses in the linear elastic model without reinforcement and Figure 5 and Figure 6 show the stress distribution in the reinforced linear elastic concrete with the rebars and the fibers respectively. The stress level in the concrete is lowered when the rebars are added.

Figure 8 and Figure 9 show axial stresses in the rebars and fibers respectively. Although the fibers are modeled as linear elastic material, they provide the same results as the elastoplastic rebars because no plastic deformation occurs.

para(15)=0.35

von Mises stress (MPa)

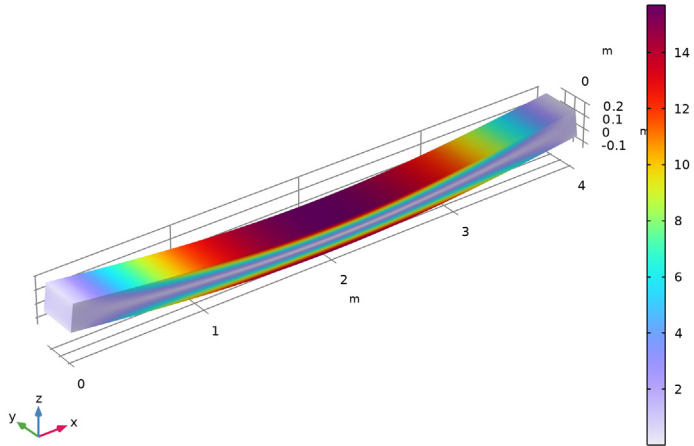

Figure 4: von Mises stress in a linear elastic beam.

para(11)=0.25

von Mises stress (MPa)

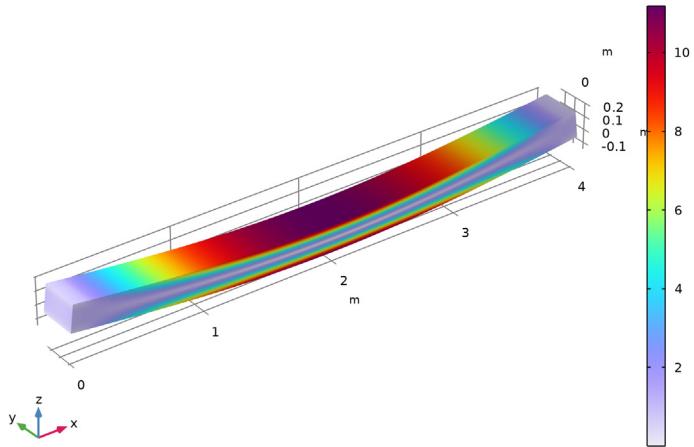

Figure 5: von Mises stress in a linear elastic beam after adding the reinforcement bars.

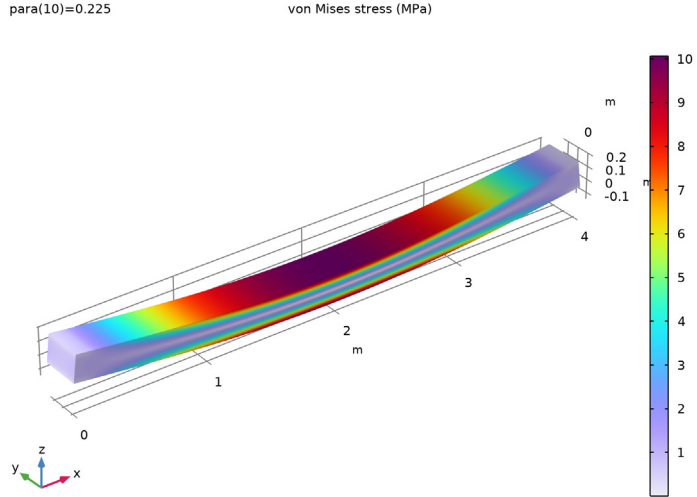

Figure 6: von Mises stress in a linear elastic beam after adding the fibers.

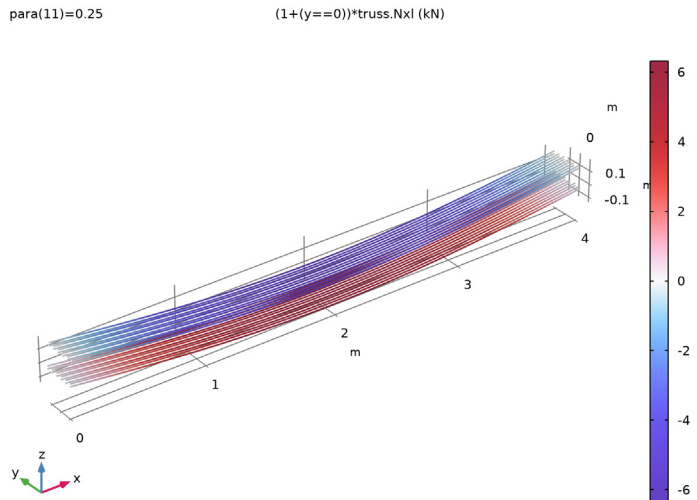

Figure 7: Axial force in the reinforcements bars. An extra multiplier is used on the bars in the symmetry plane in order to get the total force.

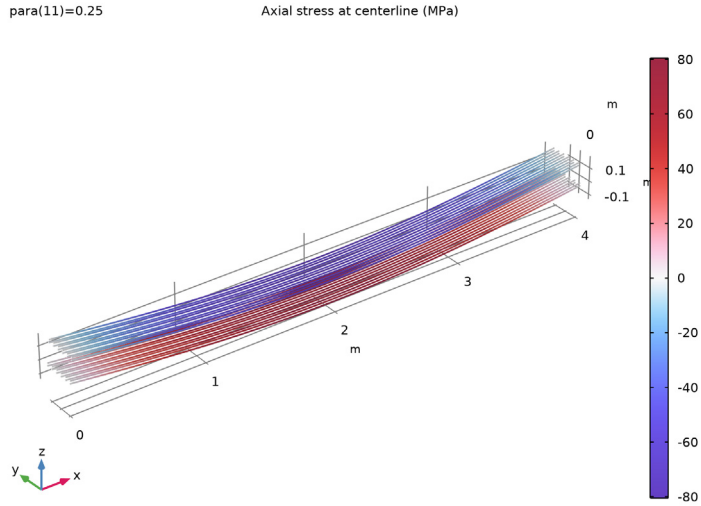

Figure 8: Axial stress in the steel rebars.

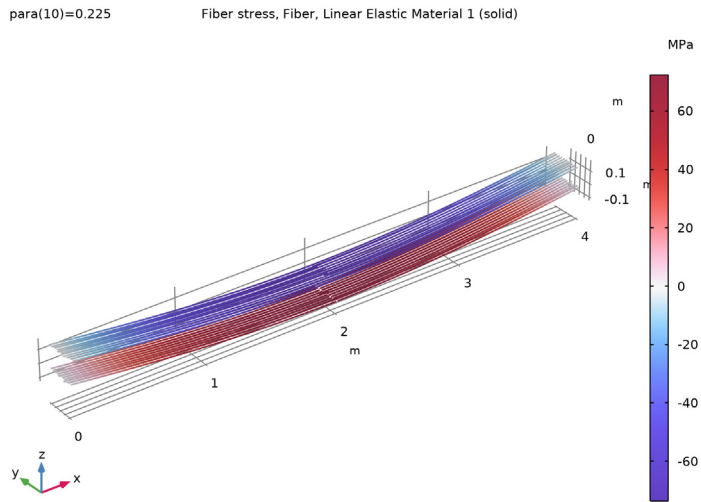

Figure 9: Axial stress in the steel fibers.

Figure 10 shows the von Mises stress in the concrete beam with Ottosen criterion, while Figure 11 shows the von Mises stress in the concrete with Mazars damage model. For these two models, the stress is of the same order of magnitude and the peak stress is located at similar locations.

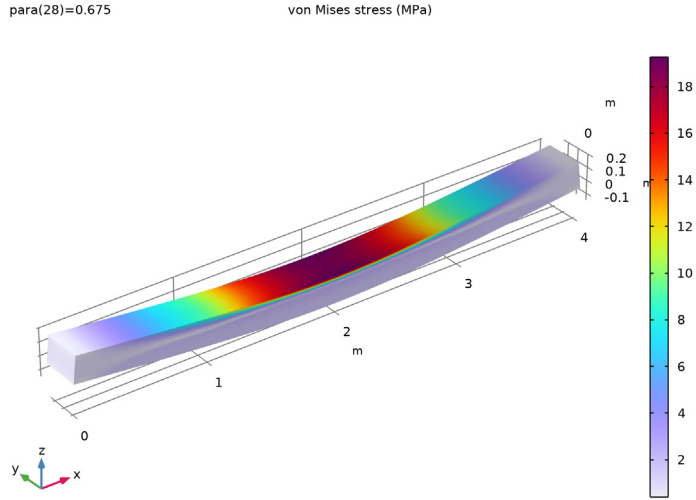

Figure 10: von Mises stress in the reinforced beam after adding the Ottosen criterion for the concrete.

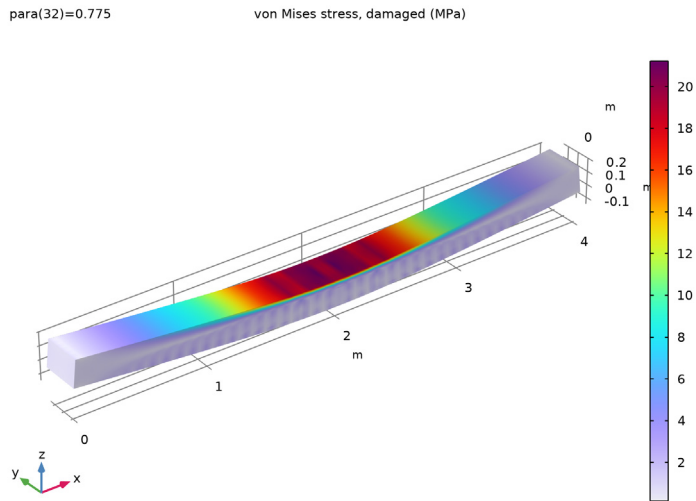

Figure 11: Von Mises stress in reinforced beams when using Mazars damage for the concrete.

Comparing Figure 12 and Figure 13, the plastic region in the Ottosen model can be seen to be similar to the damaged region of Mazars damage model.

para(28)=0.675

Elementwise maximum over Gauss points

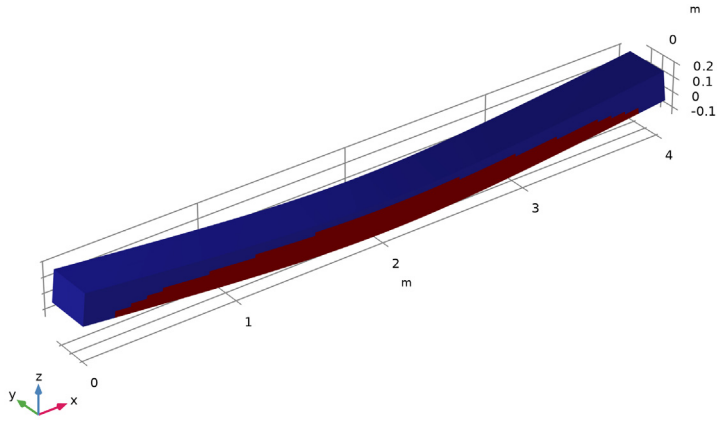

Figure 12: Plastic region in concrete with Ottosen model.

para(32)=0.775

Damage (1)

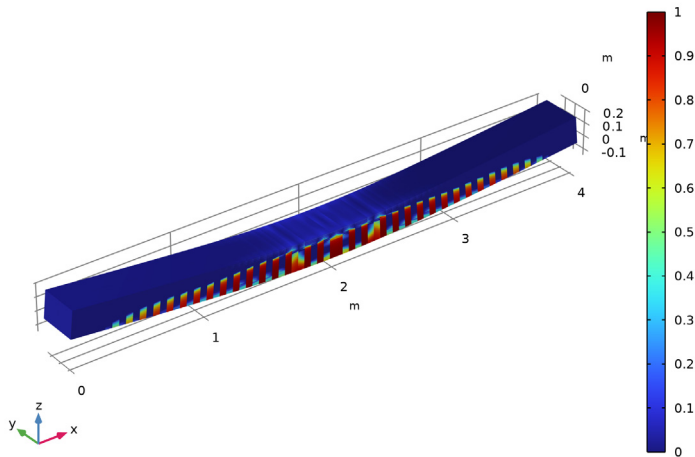

Figure 13: Damaged region in concrete with Mazars damage model.

Figure 14 gives a visualization of the crack distribution in the Mazars damage model. Here, and in Figure 13, an artifact can be seen in the center of the beam. It is an effect of the symmetry assumption, and the plot actually is created by mirroring the results from half the model. If the full model had been analyzed, the crack pattern would be slightly different.

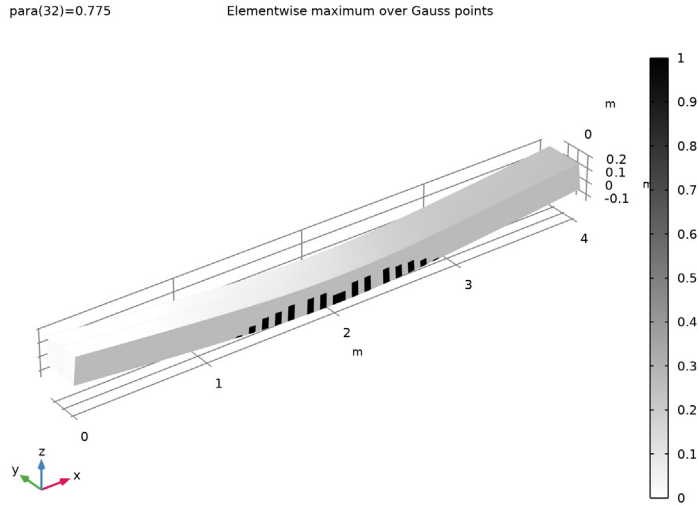

Figure 14: Locations of cracks in the Mazars damage model.

The load curves in Figure 15 show that the beams with the Ottosen and Mazars models have the same behavior, with damage starting when the load reaches about 20 kN/m^2 . The rebars start to yield slightly below 40 kN/m^2 .

In Figure 16, the plastic strain in the rebars is compared between the models. In the damage model, there is a jump between solid elements which are considered cracked or not. In the case of a pure elastic model for the concrete, the rebars never reach the yield stress.

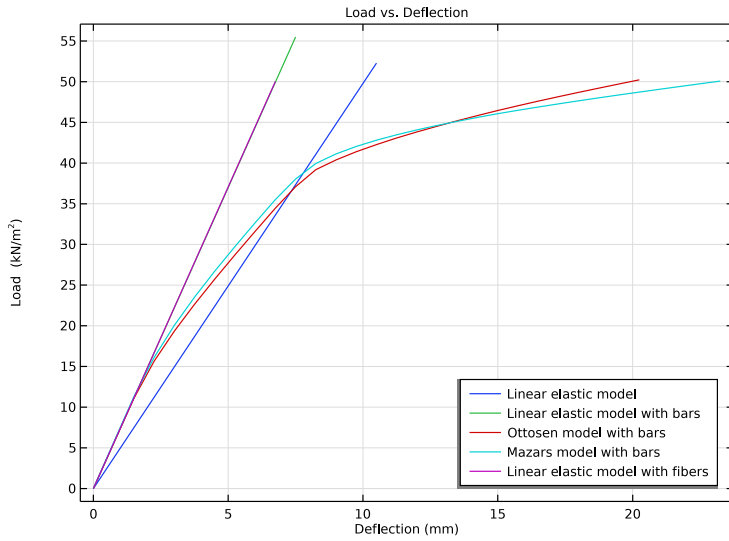

Figure 15: Load versus deflection for each concrete beam model.

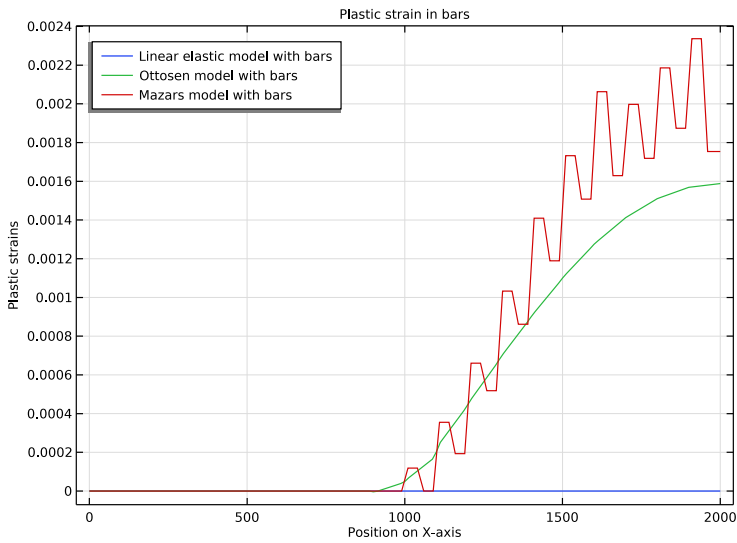

Figure 16: Comparison of plastic strains along one of the rebars.

Notes About the COMSOL Implementation

Since steel reinforcement bars are relatively thin compared to concrete structures, it is assumed that they are only capable of transmitting axial forces. The bending stiffness of each bar does not contribute much to the overall total bending stiffness of the section, therefore the reinforcement bars are modeled with *truss* elements instead of *beam* elements.

In civil engineering, it is also common practice that the rebars are pretensioned, but this effect is not included in the example. However, it can easily be incorporated by adding initial strain in the trusses.

In this example, the concrete is “glued” to the steel rebars, so bonding effects are not included.

The connection technique used in this example works well as long as the total stiffness of the rebars is smaller than the stiffness contribution from the concrete. Also, the size of the solid elements should be significantly larger than the physical volume occupied by the rebars passing through them. A very refined mesh would actually show stresses in the solids that increase without bounds where the rebars are attached.

In many cases, the rebars are so close to each other that modeling them individually is not a feasible strategy. In that case, you can consider them as thin, usually orthotropic, sheets. Instead of a Truss interface, you then use a Membrane interface. The modeling technique is similar in other respects. If no plastic deformation occurs in the rebars, then another option is to consider them as an additional axial stress distributed all over the domain. This last option has been used in the last study and it was obtained through the Fiber feature. The Young’s modulus used in the Fiber feature is the sum of the rebars and the beam one. This is done to obtain results comparable with the Truss interface method which simply adds the rebars stiffness to the concrete instead of replacing it in the area effectively occupied by them.

In all studies, the load is implicitly prescribed using an extra variable measuring the deflection. This is necessary only for the case with the Mazars damage model. It is usually difficult to obtain convergence in damage models under pure load control. A **Global Equation** node is used to define this auxiliary variable.

Reference

1. W.F. Chen, *Plasticity in Reinforced Concrete*, McGraw Hill, 1982.

Application Library path: Geomechanics_Module/Concrete/concrete_beam



Modeling Instructions

From the **File** menu, choose **New**.

NEW

In the **New** window, click  **Model Wizard**.

MODEL WIZARD

- 1 In the **Model Wizard** window, click  **3D**.
- 2 In the **Select Physics** tree, select **Structural Mechanics > Solid Mechanics (solid)**.
- 3 Click **Add**.
- 4 In the **Select Physics** tree, select **Structural Mechanics > Truss (truss)**.
- 5 Click **Add**.
- 6 Click  **Study**.
- 7 In the **Select Study** tree, select **General Studies > Stationary**.
- 8 Click  **Done**.

GLOBAL DEFINITIONS

Parameters 1

- 1 In the **Model Builder** window, under **Global Definitions** click **Parameters 1**.
- 2 In the **Settings** window for **Parameters**, locate the **Parameters** section.
- 3 Click  **Load from File**.
- 4 Browse to the model's Application Libraries folder and double-click the file `concrete_beam_parameters.txt`.

GEOMETRY 1

Block 1 (blk1)

- 1 In the **Geometry** toolbar, click  **Block**.
- 2 In the **Settings** window for **Block**, locate the **Size and Shape** section.
- 3 In the **Width** text field, type `length/2`.

4 In the **Depth** text field, type $\text{width}/2$.

5 In the **Height** text field, type height .

Subdivide the beam in three domains to easily select the regions where the Fiber feature should be active.

6 Click to expand the **Layers** section. In the table, enter the following settings:

Layer name	Thickness (m)
Layer 1	$\text{height_reinforcement}$
Layer 2	$\text{height}-2*\text{height_reinforcement}$

Line Segment 1 (ls1)

1 In the **Geometry** toolbar, click  **More Primitives** and choose **Line Segment**.

2 In the **Settings** window for **Line Segment**, locate the **Starting Point** section.

3 From the **Specify** list, choose **Coordinates**.

4 Locate the **Endpoint** section. From the **Specify** list, choose **Coordinates**.

5 In the **x** text field, type $\text{length}/2$.

6 Locate the **Starting Point** section. In the **y** text field, type $(\text{bars_across_width}-1)/2*\text{width_spacing}$.

7 Locate the **Endpoint** section. In the **y** text field, type $(\text{bars_across_width}-1)/2*\text{width_spacing}$.

8 Locate the **Starting Point** section. In the **z** text field, type $\text{layer_spacing_first}$.

9 Locate the **Endpoint** section. In the **z** text field, type $\text{layer_spacing_first}$.

10 Locate the **Selections of Resulting Entities** section. Find the **Cumulative selection** subsection. Click **New**.

11 In the **New Cumulative Selection** dialog, type **Bars Inside Domain** in the **Name** text field.

12 Click **OK**.

Array 1 (arr1)

1 In the **Geometry** toolbar, click  **Transforms** and choose **Array**.

2 In the **Settings** window for **Array**, locate the **Input** section.

3 From the **Input objects** list, choose **Bars Inside Domain**.

4 Locate the **Size** section. In the **y size** text field, type $\text{floor}(\text{bars_across_width}/2)$.

5 Locate the **Displacement** section. In the **y** text field, type $-\text{width_spacing}$.

Line Segment 2 (ls2)

- 1 In the **Geometry** toolbar, click  **More Primitives** and choose **Line Segment**.
- 2 In the **Settings** window for **Line Segment**, locate the **Starting Point** section.
- 3 From the **Specify** list, choose **Coordinates**.
- 4 Locate the **Endpoint** section. From the **Specify** list, choose **Coordinates**.
- 5 In the **x** text field, type $\text{length}/2$.
- 6 Locate the **Starting Point** section. In the **z** text field, type `layer_spacing_first`.
- 7 Locate the **Endpoint** section. In the **z** text field, type `layer_spacing_first`.
- 8 Locate the **Selections of Resulting Entities** section. Find the **Cumulative selection** subsection. Click **New**.
- 9 In the **New Cumulative Selection** dialog, type `Bars on Symmetry Plane` in the **Name** text field.
- 10 Click **OK**.

Array 2 (arr2)

- 1 In the **Geometry** toolbar, click  **Transforms** and choose **Array**.
- 2 Select the objects `arr1(1,1,1)`, `arr1(1,2,1)`, `arr1(1,3,1)`, and `ls2` only.
- 3 In the **Settings** window for **Array**, locate the **Size** section.
- 4 In the **z size** text field, type `bar_layers`.
- 5 Locate the **Displacement** section. In the **z** text field, type `layer_spacing`.

Mirror 1 (mir1)

- 1 In the **Geometry** toolbar, click  **Transforms** and choose **Mirror**.

2 Select all six bars.

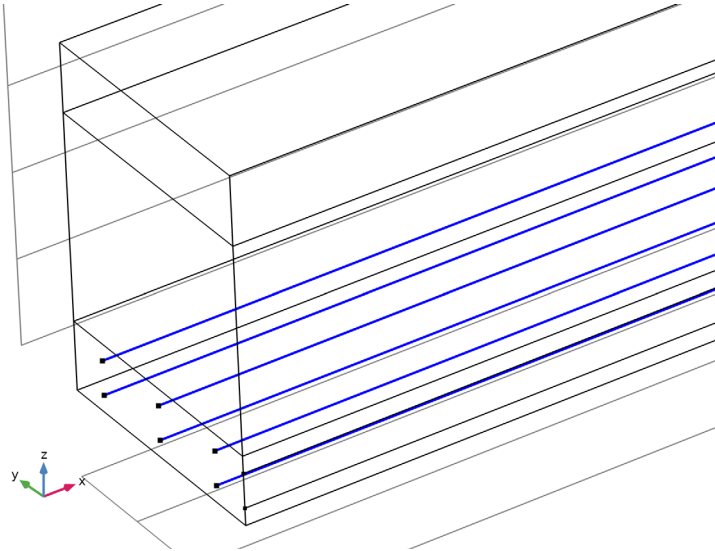

3 In the **Settings** window for **Mirror**, locate the **Point on Plane of Reflection** section.

4 In the **z** text field, type $\text{height}/2$.

5 Click  **Build All Objects**.

6 Locate the **Input** section. Select the **Keep input objects** checkbox.

7 Click  **Build All Objects**.

Form Union (fin)

1 In the **Model Builder** window, under **Component 1 (comp1) > Geometry 1** click **Form Union (fin)**.

2 In the **Settings** window for **Form Union/Assembly**, locate the **Form Union/Assembly** section.

3 From the **Action** list, choose **Form an assembly**.

4 Clear the **Create pairs** checkbox.

Line Segment 2 (ls2)

Bars in the symmetry plane must be created only in case of odd number of bars. Add an **if** condition to the creation of the first bar.

If 1 (if1)

1 In the **Geometry** toolbar, click  **Programming** and choose **Add Before Selected > If**.

2 In the **Settings** window for **If**, locate the **If** section.



3 In the **Condition** text field, type `mod(bars_across_width,2)==1`.

End If I (endifI)

- 1 In the **Geometry** toolbar, click  **Programming** and choose **Add After Selected > End If**.
- 2 In the **Settings** window for **End If**, click  **Build All Objects**.

DEFINITIONS

Bars

- 1 In the **Definitions** toolbar, click  **Union**.
- 2 In the **Settings** window for **Union**, type Bars in the **Label** text field.
- 3 Locate the **Geometric Entity Level** section. From the **Level** list, choose **Edge**.
- 4 Locate the **Input Entities** section. Under **Selections to add**, click  **Add**.
- 5 In the **Add** dialog, in the **Selections to add** list, choose **Bars Inside Domain** and **Bars on Symmetry Plane**.
- 6 Click **OK**.

Deflection

- 1 In the **Definitions** toolbar, click  **Nonlocal Couplings** and choose **Integration**.
- 2 In the **Settings** window for **Integration**, locate the **Source Selection** section.
- 3 From the **Geometric entity level** list, choose **Point**.
- 4 In the **Label** text field, type Deflection.
- 5 Select Point 12 only.
- 6 Locate the **Advanced** section. From the **Frame** list, choose **Material (X, Y, Z)**.

SOLID MECHANICS (SOLID)

Linear Elastic Material I

To model the failure of the material, add a material model to the Solid Mechanics interface.

- 1 In the **Model Builder** window, under **Component 1 (comp1) > Solid Mechanics (solid)** click **Linear Elastic Material 1**.

Concrete I

- 1 In the **Physics** toolbar, click  **Attributes** and choose **Concrete**.
- 2 In the **Settings** window for **Concrete**, locate the **Concrete Model** section.
- 3 From the **Yield function** list, choose **Ottosen**.

Symmetry 1

- 1 In the **Physics** toolbar, click  **Boundaries** and choose **Symmetry**.
- 2 Select Boundaries 2, 5, 8, and 14–16 only.

Rigid Connector 1

- 1 In the **Physics** toolbar, click  **Boundaries** and choose **Rigid Connector**.
- 2 Select Boundaries 1, 4, and 7 only.
- 3 In the **Settings** window for **Rigid Connector**, locate the **Prescribed Displacement at Center of Rotation** section.
- 4 Select the **Prescribed in y direction** checkbox.
- 5 Select the **Prescribed in z direction** checkbox.
- 6 Locate the **Prescribed Rotation** section. From the **By** list, choose **Constrained rotation**.
- 7 Select the **Constrain rotation around x-axis** checkbox.
- 8 Select the **Constrain rotation around z-axis** checkbox.

The applied load is controlled through the deflection of the midsurface.

Boundary Load 1

- 1 In the **Physics** toolbar, click  **Boundaries** and choose **Boundary Load**.
- 2 Select Boundary 10 only.
- 3 In the **Settings** window for **Boundary Load**, locate the **Force** section.
- 4 Specify the \mathbf{f}_A vector as

0	x
0	y
load	z

- 5 Click the  **Show More Options** button in the **Model Builder** toolbar.
- 6 In the **Show More Options** dialog, in the tree, select the checkbox for the node **Physics > Equation Contributions**.
- 7 Click **OK**.

Global Equations 1 (ODE1)

- 1 In the **Physics** toolbar, click  **Global** and choose **Global Equations**.
- 2 In the **Settings** window for **Global Equations**, locate the **Global Equations** section.

3 In the table, enter the following settings:

Name	f(u,ut,utt,t) (l)	Initial value (u_0) (l)	Initial value (ut_0) (l/s)	Description
load	intop1(w) - para* max_defl	0	0	

4 Locate the **Units** section. Click  **Select Dependent Variable Quantity**.

5 In the **Physical Quantity** dialog, type face in the text field.

6 In the tree, select **Solid Mechanics > Face load (N/m^2)**.

7 Click **OK**.

8 In the **Settings** window for **Global Equations**, locate the **Units** section.

9 Click  **Select Source Term Quantity**.

10 In the **Physical Quantity** dialog, type displ in the text field.

11 In the tree, select **General > Displacement (m)**.

12 Click **OK**.

TRUSS (TRUSS)

1 In the **Model Builder** window, under **Component 1 (comp1)** click **Truss (truss)**.

2 In the **Settings** window for **Truss**, locate the **Edge Selection** section.

3 From the **Selection** list, choose **Bars**.

Change the discretization for the truss elements to match the solid.

Click to expand the **Discretization** section. From the **Displacement field** list, choose **Quadratic**.

Linear Elastic Material 1

In the **Model Builder** window, under **Component 1 (comp1) > Truss (truss)** click **Linear Elastic Material 1**.

Plasticity 1

In the **Physics** toolbar, click  **Attributes** and choose **Plasticity**.

Cross-Section Data 1

The bars in the midplane should only use half of the true area.

1 In the **Model Builder** window, under **Component 1 (comp1) > Truss (truss)** click **Cross-Section Data 1**.

- 2 In the **Settings** window for **Cross-Section Data**, locate the **Cross-Section Definition** section.
- 3 In the *A* text field, type $\pi * (\text{diam_bar} / 2)^2 * (0.5 + 0.5 * Y > 0.1 [\text{mm}])$.



Add an **Embedded Reinforcement** multiphysics coupling to connect the bars with the solid domain.

MULTIPHYSICS

Embedded Reinforcement 1 (ere1)

- 1 In the **Physics** toolbar, click  **Multiphysics Couplings** and choose **Global > Embedded Reinforcement**.
- 2 In the **Settings** window for **Embedded Reinforcement**, locate the **Edge Selection, Embedded Structure** section.
- 3 From the **Selection** list, choose **Bars Inside Domain**.

ADD MATERIAL

- 1 In the **Materials** toolbar, click  **Add Material** to open the **Add Material** window.
- 2 Go to the **Add Material** window.
- 3 In the tree, select **Built-in > Concrete**.
- 4 Click the **Add to Component** button in the window toolbar.
- 5 In the tree, select **Built-in > Structural steel**.
- 6 Click the **Add to Component** button in the window toolbar.
- 7 In the **Materials** toolbar, click  **Add Material** to close the **Add Material** window.

MATERIALS

Concrete (mat1)

- 1 In the **Settings** window for **Material**, locate the **Material Contents** section.
- 2 In the table, enter the following settings:

Property	Variable	Value	Unit	Property group
Compressive strength	sigmauc	20e6	Pa	Yield stress parameters
Ottosen a parameter	aOttosen	1.3	l	Ottosen
Ottosen b parameter	bOttosen	3.2	l	Ottosen
Size factor	k1Ottosen	11.8	l	Ottosen
Shape factor	k2Ottosen	0.98	l	Ottosen

Structural steel (mat2)

- 1 In the **Model Builder** window, click **Structural steel (mat2)**.
- 2 In the **Settings** window for **Material**, locate the **Geometric Entity Selection** section.
- 3 From the **Geometric entity level** list, choose **Edge**.
- 4 From the **Selection** list, choose **Bars**.
- 5 Locate the **Material Contents** section. In the table, enter the following settings:

Property	Variable	Value	Unit	Property group
Initial yield stress	sigmags	100 [MPa]	Pa	Elastoplastic material model
Isotropic tangent modulus	Et	20 [GPa]	Pa	Elastoplastic material model

MESH 1

Edge 1

- 1 In the **Mesh** toolbar, click  **More Generators** and choose **Edge**.
- 2 In the **Settings** window for **Edge**, locate the **Edge Selection** section.
- 3 From the **Selection** list, choose **Bars**.

Distribution 1

- 1 Right-click **Edge 1** and choose **Distribution**.
- 2 In the **Settings** window for **Distribution**, locate the **Distribution** section.
- 3 In the **Number of elements** text field, type 20*mesh_par.

Mapped 1

- 1 In the **Mesh** toolbar, click  **More Generators** and choose **Mapped**.
- 2 Select Boundaries 1, 4, and 7 only.

Distribution 1

- 1 Right-click **Mapped 1** and choose **Distribution**.
- 2 Select Edges 4 and 10 only.
- 3 In the **Settings** window for **Distribution**, locate the **Distribution** section.
- 4 In the **Number of elements** text field, type 6*mesh_par.

Distribution 2

- 1 In the **Model Builder** window, right-click **Mapped 1** and choose **Distribution**.
- 2 Select Edges 1 and 7 only.

- 3 In the **Settings** window for **Distribution**, locate the **Distribution** section.
- 4 In the **Number of elements** text field, type 2*mesh_par.

Swept 1

In the **Mesh** toolbar, click  **Swept**.

Distribution 1

- 1 Right-click **Swept 1** and choose **Distribution**.
- 2 In the **Settings** window for **Distribution**, locate the **Distribution** section.
- 3 In the **Number of elements** text field, type 20*mesh_par.
- 4 In the **Model Builder** window, right-click **Mesh 1** and choose **Build All**.
- 5 Click the  **Go to Default View** button in the **Graphics** toolbar.



The mesh should look like the one in [Figure 2](#).

WITHOUT BARS

The first study solves only the linear elastic problem in the concrete beam without the reinforcement bars.

- 1 In the **Model Builder** window, click **Study 1**.
- 2 In the **Settings** window for **Study**, type Without Bars in the **Label** text field.



Step 1: Stationary

- 1 In the **Model Builder** window, under **Without Bars** click **Step 1: Stationary**.
- 2 In the **Settings** window for **Stationary**, locate the **Physics and Variables Selection** section.
- 3 Select the **Modify model configuration for study step** checkbox.
- 4 In the tree, select **Component 1 (comp1) > Solid Mechanics (solid) > Linear Elastic Material 1 > Concrete 1**.
- 5 Right-click and choose **Disable**.
- 6 In the tree, select **Component 1 (comp1) > Truss (truss)**.
- 7 Click  **Disable in Model**.
- 8 In the tree, select **Component 1 (comp1) > Multiphysics > Embedded Reinforcement 1 (ere1)**.
- 9 Click  **Disable in Model**.
- 10 Click to expand the **Study Extensions** section. Select the **Auxiliary sweep** checkbox.
- 11 Click  **Add**.

12 In the table, enter the following settings:

Parameter name	Parameter value list	Parameter unit
para (Parameter used for parametric sweep)	range (0, 0.025, 1)	

Solution 1 (sol1)

- 1 In the **Study** toolbar, click  **Show Default Solver**.
- 2 In the **Model Builder** window, expand the **Solution 1 (sol1)** node.
- 3 In the **Model Builder** window, expand the **Without Bars > Solver Configurations > Solution 1 (sol1) > Stationary Solver 1** node.
- 4 Right-click **Without Bars > Solver Configurations > Solution 1 (sol1) > Stationary Solver 1 > Parametric 1** and choose **Stop Condition**.
- 5 In the **Settings** window for **Stop Condition**, locate the **Stop Expressions** section.
- 6 Click  **Add**.
- 7 In the table, enter the following settings:

Stop expression	Stop if	Active	Description
comp1.load<-50e3	True (>=1)	<input checked="" type="checkbox"/>	Stop expression 1

- 8 Locate the **Output at Stop** section. From the **Add solution** list, choose **Step after stop**.
- 9 Clear the **Add information** checkbox.
- 10 In the **Study** toolbar, click  **Compute**.

RESULTS

Mirror 3D 1

Add two mirror datasets to plot the entire beam.



- 1 In the **Model Builder** window, expand the **Results > Datasets** node.
- 2 Right-click **Results > Datasets** and choose **More 3D Datasets > Mirror 3D**.
- 3 In the **Settings** window for **Mirror 3D**, locate the **Plane Data** section.
- 4 From the **Plane** list, choose **ZX-planes**.

Mirror 3D 2

- 1 In the **Results** toolbar, click  **More Datasets** and choose **Mirror 3D**.
- 2 In the **Settings** window for **Mirror 3D**, locate the **Data** section.
- 3 From the **Dataset** list, choose **Mirror 3D 1**.

- 4 Locate the **Plane Data** section. In the **x-coordinate** text field, type $\text{length}/2$.
Set default units for result presentation.

Preferred Units I

- 1 In the **Results** toolbar, click  **Configurations** and choose **Preferred Units**.
- 2 In the **Settings** window for **Preferred Units**, locate the **Units** section.
- 3 Click  **Add Physical Quantity**.
- 4 In the **Physical Quantity** dialog, select **Solid Mechanics > Stress tensor (N/m²)** in the tree.
- 5 Click **OK**.
- 6 In the **Settings** window for **Preferred Units**, locate the **Units** section.
- 7 In the table, enter the following settings:



Quantity	Unit	Preferred unit
Stress tensor	N/m ²	MPa

- 8 Click  **Apply**.

Stress I

- 1 In the **Model Builder** window, under **Results** click **Stress (solid)**.
- 2 In the **Settings** window for **3D Plot Group**, type **Stress 1** in the **Label** text field.
- 3 Locate the **Data** section. From the **Dataset** list, choose **Mirror 3D 2**.
- 4 Locate the **Plot Settings** section. Clear the **Plot dataset edges** checkbox.

Volume I

- 1 In the **Model Builder** window, expand the **Stress I** node, then click **Volume I**.
- 2 In the **Stress I** toolbar, click  **Plot**.
- 3 Click the  **Go to Default View** button in the **Graphics** toolbar.

Before adding a second study, put the first plot group in a separate group.

Stress I



In the **Model Builder** window, right-click **Stress I** and choose **Group**.

Without Bars

In the **Settings** window for **Group**, type **Without Bars** in the **Label** text field.



ADD STUDY

Add a second study to solve the model with the reinforcement bars.

- 1 In the **Home** toolbar, click  **Add Study** to open the **Add Study** window.
- 2 Go to the **Add Study** window.
- 3 Find the **Studies** subsection. In the **Select Study** tree, select **General Studies > Stationary**.
- 4 Click the **Add Study** button in the window toolbar.
- 5 In the **Home** toolbar, click  **Add Study** to close the **Add Study** window.



STUDY 2

Step 1: Stationary

- 1 In the **Settings** window for **Stationary**, locate the **Physics and Variables Selection** section.
- 2 Select the **Modify model configuration for study step** checkbox.
- 3 In the tree, select **Component 1 (comp1) > Solid Mechanics (solid) > Linear Elastic Material 1 > Concrete 1**.
- 4 Click  **Disable**.
- 5 Locate the **Study Extensions** section. Select the **Auxiliary sweep** checkbox.
- 6 Click  **Add**.
- 7 In the table, enter the following settings:

Parameter name	Parameter value list	Parameter unit
para (Parameter used for parametric sweep)	range (0,0.025,1)	

Solution 2 (sol2)

- 1 In the **Study** toolbar, click  **Show Default Solver**.
- 2 In the **Model Builder** window, expand the **Solution 2 (sol2)** node.
- 3 In the **Model Builder** window, expand the **Study 2 > Solver Configurations > Solution 2 (sol2) > Stationary Solver 1** node.
- 4 Right-click **Study 2 > Solver Configurations > Solution 2 (sol2) > Stationary Solver 1 > Parametric 1** and choose **Stop Condition**.
- 5 In the **Settings** window for **Stop Condition**, locate the **Stop Expressions** section.
- 6 Click  **Add**.
- 7 In the table, enter the following settings:

Stop expression	Stop if	Active	Description
comp1.load<-50e3	True (>=1)	√	Stop expression 1

- 8 Locate the **Output at Stop** section. From the **Add solution** list, choose **Step after stop**.
- 9 Clear the **Add information** checkbox.
- 10 In the **Model Builder** window, click **Study 2**.
- 11 In the **Settings** window for **Study**, type With Bars in the **Label** text field.
- 12 In the **Study** toolbar, click  **Compute**.

RESULTS

Mirror 3D 3

- 1 In the **Results** toolbar, click  **More Datasets** and choose **Mirror 3D**.
- 2 In the **Settings** window for **Mirror 3D**, locate the **Data** section.
- 3 From the **Dataset** list, choose **With Bars/Solution 2 (sol2)**.
- 4 Locate the **Plane Data** section. From the **Plane** list, choose **ZX-planes**.
- 5 In the **Y-coordinate** text field, type $-1e-10$.

Mirror 3D 4



- 1 In the **Results** toolbar, click  **More Datasets** and choose **Mirror 3D**.
- 2 In the **Settings** window for **Mirror 3D**, locate the **Data** section.
- 3 From the **Dataset** list, choose **Mirror 3D 3**.
- 4 Locate the **Plane Data** section. In the **x-coordinate** text field, type $\text{length}/2$.

Stress 2

The first default plot shows the von Mises stress, [Figure 5](#). This result can be compared to the result without reinforcement bars, [Figure 4](#).

- 1 In the **Model Builder** window, under **Results** click **Stress (solid)**.
- 2 In the **Settings** window for **3D Plot Group**, type **Stress 2** in the **Label** text field.
- 3 Locate the **Data** section. From the **Dataset** list, choose **Mirror 3D 4**.
- 4 Locate the **Plot Settings** section. Clear the **Plot dataset edges** checkbox.

Volume 1



- 1 In the **Model Builder** window, expand the **Stress 2** node, then click **Volume 1**.
- 2 In the **Stress 2** toolbar, click  **Plot**.
- 3 Click the  **Zoom Extents** button in the **Graphics** toolbar.

Stress in Bars 2

The second default plot shows the axial stress in the bars, [Figure 8](#).



- 1 In the **Model Builder** window, under **Results** click **Stress (truss)**.
- 2 In the **Settings** window for **3D Plot Group**, type **Stress** in **Bars 2** in the **Label** text field.
- 3 Locate the **Data** section. From the **Dataset** list, choose **Mirror 3D 4**.
- 4 Locate the **Plot Settings** section. Clear the **Plot dataset edges** checkbox.

Line 1

- 1 In the **Model Builder** window, expand the **Stress in Bars 2** node, then click **Line 1**.
- 2 In the **Settings** window for **Line**, locate the **Expression** section.
- 3 In the **Expression** text field, type **truss.sn**.
- 4 Locate the **Coloring and Style** section. From the **Color table** list, choose **WaveLight**.
- 5 In the **Stress in Bars 2** toolbar, click  **Plot**.
- 6 Click the  **Go to Default View** button in the **Graphics** toolbar.

Add a plot that shows the force in all bars, [Figure 7](#).

RESULT TEMPLATES

- 1 In the **Results** toolbar, click  **Result Templates** to open the **Result Templates** window.
- 2 Go to the **Result Templates** window.
- 3 In the tree, select **With Bars/Solution 2 (sol2) > Truss > Force (truss)**.
- 4 Click the **Add Result Template** button in the window toolbar.
- 5 In the **Results** toolbar, click  **Result Templates** to close the **Result Templates** window.

RESULTS



Force in Bars 2

- 1 In the **Settings** window for **3D Plot Group**, type **Force** in **Bars 2** in the **Label** text field.
- 2 Locate the **Data** section. From the **Dataset** list, choose **Mirror 3D 4**.
- 3 Locate the **Plot Settings** section. Clear the **Plot dataset edges** checkbox.

Line 1

The force in the rebars in the midplane must be multiplied by 2.

- 1 In the **Model Builder** window, expand the **Force in Bars 2** node, then click **Line 1**.
- 2 In the **Settings** window for **Line**, locate the **Expression** section.
- 3 In the **Expression** text field, type $(1+(y==0))*truss.Nx1$.
- 4 In the **Unit** field, type **kN**.
- 5 Locate the **Coloring and Style** section. From the **Color table** list, choose **WaveLight**.

- 6 In the **Force in Bars 2** toolbar, click  **Plot**.
- 7 Click the  **Go to Default View** button in the **Graphics** toolbar.

Force in Bars 2, Stress 2, Stress in Bars 2



- 1 In the **Model Builder** window, under **Results**, Ctrl-click to select **Stress 2**, **Stress in Bars 2**, and **Force in Bars 2**.
- 2 Right-click and choose **Group**.

With Bars

In the **Settings** window for **Group**, type **With Bars** in the **Label** text field.

ADD STUDY

Add a third study to solve the model with concrete plasticity and reinforcement bars.

- 1 In the **Home** toolbar, click  **Add Study** to open the **Add Study** window.
- 2 Go to the **Add Study** window.
- 3 Find the **Studies** subsection. In the **Select Study** tree, select **General Studies** > **Stationary**.
- 4 Click the **Add Study** button in the window toolbar.
- 5 In the **Home** toolbar, click  **Add Study** to close the **Add Study** window.

STUDY 3

Step 1: Stationary

- 1 In the **Settings** window for **Stationary**, locate the **Study Extensions** section.
- 2 Select the **Auxiliary sweep** checkbox.
- 3 Click  **Add**.
- 4 In the table, enter the following settings:

Parameter name	Parameter value list	Parameter unit
para (Parameter used for parametric sweep)	range (0, 0.025, 1)	

- 5 In the **Model Builder** window, click **Study 3**.
- 6 In the **Settings** window for **Study**, locate the **Study Settings** section.
- 7 Clear the **Generate default plots** checkbox.

Solution 3 (sol3)

- 1 In the **Study** toolbar, click  **Show Default Solver**.
- 2 In the **Model Builder** window, expand the **Solution 3 (sol3)** node.

- 3 In the **Model Builder** window, expand the **Study 3 > Solver Configurations > Solution 3 (sol3) > Stationary Solver I** node, then click **Parametric I**.
- 4 In the **Settings** window for **Parametric**, click to expand the **Continuation** section.
- 5 From the **Predictor** list, choose **Constant** to improve the convergence for the elastoplastic case.
- 6 Right-click **Study 3 > Solver Configurations > Solution 3 (sol3) > Stationary Solver I > Parametric I** and choose **Stop Condition**.
- 7 In the **Settings** window for **Stop Condition**, locate the **Stop Expressions** section.
- 8 Click  **Add**.
- 9 In the table, enter the following settings:

Stop expression	Stop if	Active	Description
comp1.load<-50e3	True (>=1)	<input checked="" type="checkbox"/>	Stop expression 1

- 10 Locate the **Output at Stop** section. From the **Add solution** list, choose **Step after stop**.
- 11 Clear the **Add information** checkbox.
- 12 In the **Model Builder** window, click **Study 3**.
- 13 In the **Settings** window for **Study**, type **With Bars** and **Ottosen** in the **Label** text field.
- 14 In the **Study** toolbar, click  **Compute**.

RESULTS

Mirror 3D 5

- 1 In the **Results** toolbar, click  **More Datasets** and choose **Mirror 3D**.
- 2 In the **Settings** window for **Mirror 3D**, locate the **Data** section.
- 3 From the **Dataset** list, choose **With Bars and Ottosen/Solution 3 (sol3)**.
- 4 Locate the **Plane Data** section. From the **Plane** list, choose **ZX-planes**.
- 5 In the **Y-coordinate** text field, type $-1e-10$.

Mirror 3D 6



- 1 In the **Results** toolbar, click  **More Datasets** and choose **Mirror 3D**.
- 2 In the **Settings** window for **Mirror 3D**, locate the **Data** section.
- 3 From the **Dataset** list, choose **Mirror 3D 5**.
- 4 Locate the **Plane Data** section. In the **x-coordinate** text field, type $\text{length}/2$.

Duplicate the plots from the previous study to compare results with or without the failure behavior.

With Bars and Ottosen

- 1 In the **Model Builder** window, right-click **With Bars** and choose **Duplicate**.
- 2 In the **Settings** window for **Group**, type **With Bars** and **Ottosen** in the **Label** text field.

Stress 3

- 1 In the **Model Builder** window, expand the **With Bars and Ottosen** node, then click **Stress 2.1**.
- 2 In the **Settings** window for **3D Plot Group**, type **Stress 3** in the **Label** text field.
- 3 Locate the **Data** section. From the **Dataset** list, choose **Mirror 3D 6**.
- 4 Click  **Plot Last**.
- 5 Click the  **Zoom Extents** button in the **Graphics** toolbar.

Stress in Bars 3

- 1 In the **Model Builder** window, under **Results > With Bars and Ottosen** click **Stress in Bars 2.1**.
- 2 In the **Settings** window for **3D Plot Group**, type **Stress in Bars 3** in the **Label** text field.
- 3 Locate the **Data** section. From the **Dataset** list, choose **Mirror 3D 6**.
- 4 Click  **Plot Last**.

Force in Bars 3

- 1 In the **Model Builder** window, click **Force in Bars 2.1**.
- 2 In the **Settings** window for **3D Plot Group**, locate the **Data** section.
- 3 From the **Dataset** list, choose **Mirror 3D 6**.
- 4 In the **Label** text field, type **Force in Bars 3**.
- 5 Click  **Plot Last**.

Add a plot group to visualize the plastic zone like in [Figure 12](#).

Plastic Region

- 1 In the **Results** toolbar, click  **3D Plot Group**.
- 2 In the **Settings** window for **3D Plot Group**, locate the **Data** section.
- 3 From the **Dataset** list, choose **Mirror 3D 6**.
- 4 In the **Label** text field, type **Plastic Region**.



Surface 1

- 1 Right-click **Plastic Region** and choose **Surface**.
- 2 In the **Settings** window for **Surface**, locate the **Expression** section.
- 3 In the **Expression** text field, type `solid.elemgpmax(solid.epε>0)`.
- 4 Locate the **Coloring and Style** section. Clear the **Color legend** checkbox.
- 5 Click to expand the **Quality** section. From the **Evaluation settings** list, choose **Manual**.
- 6 From the **Smoothing** list, choose **None**.

Deformation 1

Right-click **Surface 1** and choose **Deformation**.

Plastic Region

- 1 In the **Settings** window for **3D Plot Group**, click to expand the **Title** section.
- 2 Locate the **Plot Settings** section. Clear the **Plot dataset edges** checkbox.
- 3 Click  **Plot Last**.
- 4 Click the  **Go to Default View** button in the **Graphics** toolbar.



SOLID MECHANICS (SOLID)

To model the failure of the material using a damage model, some additional features and properties are added.

Linear Elastic Material 1

In the **Model Builder** window, under **Component 1 (comp1) > Solid Mechanics (solid)** click **Linear Elastic Material 1**.

Concrete 2

- 1 In the **Physics** toolbar, click  **Attributes** and choose **Concrete**.
- 2 In the **Settings** window for **Concrete**, locate the **Concrete Model** section.
- 3 From the **Material model** list, choose **Mazars damage**.
- 4 From the ϵ_{eq} list, choose **Modified Mazars**.
- 5 Find the **Compressive damage evolution** subsection. In the ϵ_{0c} text field, type `1e-4`.
- 6 In the A_c text field, type `1.12`.
- 7 Click the  **Show More Options** button in the **Model Builder** toolbar.
- 8 In the **Show More Options** dialog, in the tree, select the checkbox for the node **Physics > Advanced Physics Options**.
- 9 Click **OK**.

Discretization, Linear

1 In the **Physics** toolbar, click  **Global** and choose **Discretization**.

For the crack band method, linear shape order for the displacements is preferred.

2 In the **Settings** window for **Discretization**, type Discretization, Linear in the **Label** text field.

3 Locate the **Discretization** section. From the **Displacement field** list, choose **Linear**.

TRUSS (TRUSS)

Discretization, Linear

1 In the **Physics** toolbar, click  **Global** and choose **Discretization**.

2 In the **Settings** window for **Discretization**, type Discretization, Linear in the **Label** text field.

MATERIALS

Concrete (mat1)

1 In the **Model Builder** window, under **Component 1 (comp1) > Materials** click **Concrete (mat1)**.

2 In the **Settings** window for **Material**, locate the **Material Contents** section.

3 In the table, enter the following settings:

Property	Variable	Value	Unit	Property group
Tensile strength	sigmat	2 [MPa]	Pa	Yield stress parameters
Fracture energy per area	Gft	220 [J/m ²]	J/m ²	Fracture parameters

ADD STUDY

Add a fourth study to solve the model with Mazars damage model and reinforcement bars.

1 In the **Home** toolbar, click  **Add Study** to open the **Add Study** window.

2 Go to the **Add Study** window.

3 Find the **Studies** subsection. In the **Select Study** tree, select **General Studies > Stationary**.



4 Click the **Add Study** button in the window toolbar.

5 In the **Home** toolbar, click  **Add Study** to close the **Add Study** window.

Since a linear shape order is used for the displacements, the number of elements is increased by a factor 2 using the `mesh_par` parameter.

STUDY 4

Parametric Sweep

- 1 In the **Study** toolbar, click  **Parametric Sweep**.
- 2 In the **Settings** window for **Parametric Sweep**, locate the **Study Settings** section.
- 3 Click  **Add**.
- 4 In the table, enter the following settings:

Parameter name	Parameter value list	Parameter unit
mesh_par (Mesh distribution multiplier)	2	

Step 1: Stationary

- 1 In the **Model Builder** window, click **Step 1: Stationary**.
- 2 In the **Settings** window for **Stationary**, locate the **Physics and Variables Selection** section.
- 3 Select the **Modify model configuration for study step** checkbox.
- 4 In the tree, select **Component 1 (comp1) > Solid Mechanics (solid)**.
- 5 From the **Discretization** list, choose **Discretization, Linear**.
- 6 In the tree, select **Component 1 (comp1) > Truss (truss)**.
- 7 From the **Discretization** list, choose **Discretization, Linear**.
- 8 Locate the **Study Extensions** section. Select the **Auxiliary sweep** checkbox.
- 9 Click  **Add**.
- 10 In the table, enter the following settings:

Parameter name	Parameter value list	Parameter unit
para (Parameter used for parametric sweep)	range (0, 0.025, 1)	

- 11 In the **Model Builder** window, click **Study 4**.
- 12 In the **Settings** window for **Study**, locate the **Study Settings** section.
- 13 Clear the **Generate default plots** checkbox.

Solution 4 (sol4)

- 1 In the **Study** toolbar, click  **Show Default Solver**.
- 2 In the **Model Builder** window, expand the **Solution 4 (sol4)** node.
- 3 In the **Model Builder** window, expand the **Study 4 > Solver Configurations > Solution 4 (sol4) > Stationary Solver 1** node.

4 Right-click **Study 4 > Solver Configurations > Solution 4 (sol4) > Stationary Solver I > Parametric I** and choose **Stop Condition**.

5 In the **Settings** window for **Stop Condition**, locate the **Stop Expressions** section.

6 Click **+ Add**.

7 In the table, enter the following settings:

Stop expression	Stop if	Active	Description
comp1.load<-50e3	True (>=1)	√	Stop expression 1

8 Locate the **Output at Stop** section. From the **Add solution** list, choose **Step after stop**.

9 Clear the **Add information** checkbox.

10 In the **Model Builder** window, click **Study 4**.

11 In the **Settings** window for **Study**, type **With Bars** and **Damage** in the **Label** text field.

12 In the **Study** toolbar, click **= Compute**.

RESULTS

Mirror 3D 7

1 In the **Results** toolbar, click  **More Datasets** and choose **Mirror 3D**.

2 In the **Settings** window for **Mirror 3D**, locate the **Data** section.

3 From the **Dataset** list, choose **With Bars and Damage/Solution 4 (sol4)**.

4 Locate the **Plane Data** section. From the **Plane** list, choose **ZX-planes**.

5 In the **Y-coordinate** text field, type $-1e-10$.

Mirror 3D 8

1 In the **Results** toolbar, click  **More Datasets** and choose **Mirror 3D**.

2 In the **Settings** window for **Mirror 3D**, locate the **Data** section.

3 From the **Dataset** list, choose **Mirror 3D 7**.

4 Locate the **Plane Data** section. In the **x-coordinate** text field, type $\text{length}/2$.

With Bars and Damage

1 In the **Model Builder** window, right-click **With Bars** and choose **Duplicate**.

2 In the **Settings** window for **Group**, type **With Bars** and **Damage** in the **Label** text field.



Stress 4

1 In the **Model Builder** window, expand the **With Bars and Damage** node, then click **Stress 2.1**.

- 2 In the **Settings** window for **3D Plot Group**, type `Stress 4` in the **Label** text field.
- 3 Locate the **Data** section. From the **Dataset** list, choose **Mirror 3D 8**.

Change the plot variable to show the damaged stress measure (Figure 11).

Volume 1

- 1 In the **Model Builder** window, expand the **Stress 4** node, then click **Volume 1**.
- 2 In the **Settings** window for **Volume**, locate the **Expression** section.
- 3 In the **Expression** text field, type `solid.misesdGp`.
- 4 Click  **Plot Last**.
- 5 Click the  **Zoom Extents** button in the **Graphics** toolbar.

Stress in Bars 4

- 1 In the **Model Builder** window, under **Results > With Bars and Damage** click **Stress in Bars 2.1**.
- 2 In the **Settings** window for **3D Plot Group**, type `Stress in Bars 4` in the **Label** text field.
- 3 Locate the **Data** section. From the **Dataset** list, choose **Mirror 3D 8**.
- 4 Click  **Plot Last**.

Force in Bars 4

- 1 In the **Model Builder** window, click **Force in Bars 2.1**.
- 2 In the **Settings** window for **3D Plot Group**, locate the **Data** section.
- 3 From the **Dataset** list, choose **Mirror 3D 8**.
- 4 In the **Label** text field, type `Force in Bars 4`.
- 5 Click  **Plot Last**.

Add a plot group to visualize the damage and reproduce Figure 13.

Damage

- 1 In the **Results** toolbar, click  **3D Plot Group**.
- 2 In the **Settings** window for **3D Plot Group**, locate the **Data** section.
- 3 From the **Dataset** list, choose **Mirror 3D 8**.
- 4 In the **Label** text field, type `Damage`.

Surface 1



- 1 Right-click **Damage** and choose **Surface**.
- 2 In the **Settings** window for **Surface**, locate the **Expression** section.
- 3 In the **Expression** text field, type `solid.dmgGp`.

- 4 Locate the **Quality** section. From the **Evaluation settings** list, choose **Manual**.
- 5 From the **Resolution** list, choose **No refinement**.
- 6 From the **Smoothing** list, choose **None**.

Deformation I

Right-click **Surface I** and choose **Deformation**.

Damage

- 1 In the **Settings** window for **3D Plot Group**, locate the **Plot Settings** section.
- 2 Clear the **Plot dataset edges** checkbox.
- 3 Click  **Plot Last**.
- 4 Click the  **Go to Default View** button in the **Graphics** toolbar.

Add an additional plot group to visualize the active cracks and reproduce [Figure 14](#).

Cracks

- 1 In the **Results** toolbar, click  **3D Plot Group**.
- 2 In the **Settings** window for **3D Plot Group**, locate the **Data** section.
- 3 From the **Dataset** list, choose **Mirror 3D 8**.
- 4 In the **Label** text field, type Cracks.



Surface I

- 1 Right-click **Cracks** and choose **Surface**.
- 2 In the **Settings** window for **Surface**, click **Replace Expression** in the upper-right corner of the **Expression** section. From the menu, choose **Component I (comp1) > Solid Mechanics > Damage > solid.eeqGp - Equivalent strain - I**.
- 3 Locate the **Expression** section. In the **Expression** text field, type `solid.elemgpmx(solid.eeq>2e-3)`.
- 4 Locate the **Coloring and Style** section. From the **Color table** list, choose **GrayScale**.
- 5 From the **Color table transformation** list, choose **Reverse**.
- 6 Locate the **Quality** section. From the **Evaluation settings** list, choose **Manual**.
- 7 From the **Resolution** list, choose **No refinement**.
- 8 From the **Smoothing** list, choose **None**.

Deformation I

Right-click **Surface I** and choose **Deformation**.

Cracks

- 1 In the **Settings** window for **3D Plot Group**, locate the **Plot Settings** section.
- 2 Clear the **Plot dataset edges** checkbox.
- 3 Click  **Plot Last**.
- 4 Click the  **Go to Default View** button in the **Graphics** toolbar.



SOLID MECHANICS (SOLID)

Add a fifth study to solve the linear elastic model using fibers instead of the Truss interface.

Linear Elastic Material 1

In the **Model Builder** window, under **Component 1 (comp1) > Solid Mechanics (solid)** click **Linear Elastic Material 1**.

Fiber 1

- 1 In the **Physics** toolbar, click  **Attributes** and choose **Fiber**.
Apply fibers only on the top and bottom layer of the beam. The fiber are made of steel.
- 2 In the **Settings** window for **Fiber**, locate the **Domain Selection** section.
- 3 In the list box, select **2**.
- 4 Click  **Remove from Selection**.
- 5 Select Domains 1 and 3 only.
- 6 Locate the **Fiber Model** section. From the **Material** list, choose **Structural steel (mat2)**.
- 7 Locate the **Distribution and Orientation** section. In the v_{fiber} text field, type $v_{\text{reinforcement}}$.

The **Embedded Reinforcement** multiphysics coupling used to connect the bars with the solid domain does not replace the stiffness of the concrete with the trusses' one in the overlapping region. This implies that the actual stiffness of the bar and concrete are summed. Modify the Young's modulus as the sum of the steel and concrete Young's modulus.

- 8 Locate the **Fiber Model** section. From the E_{fiber} list, choose **User defined**. In the associated text field, type $\text{mat1} . \text{Enu} . E + \text{mat2} . \text{Enu} . E$.



ADD STUDY

- 1 In the **Home** toolbar, click  **Add Study** to open the **Add Study** window.
- 2 Go to the **Add Study** window.
- 3 Find the **Studies** subsection. In the **Select Study** tree, select **General Studies > Stationary**.

- 4 Find the **Physics interfaces in study** subsection. In the table, clear the **Solve** checkbox for **Truss (truss)**.
- 5 Find the **Multiphysics couplings in study** subsection. In the table, clear the **Solve** checkbox for **Embedded Reinforcement I (ere1)**.
- 6 Click the **Add Study** button in the window toolbar.
- 7 In the **Home** toolbar, click  **Add Study** to close the **Add Study** window.



STUDY 5

Step 1: Stationary

- 1 In the **Settings** window for **Stationary**, locate the **Physics and Variables Selection** section.
- 2 Select the **Modify model configuration for study step** checkbox.
- 3 In the tree, select **Component 1 (comp1) > Solid Mechanics (solid) > Linear Elastic Material 1 > Concrete 2**.
- 4 Click  **Disable**.
- 5 In the tree, select **Component 1 (comp1) > Solid Mechanics (solid) > Linear Elastic Material 1 > Concrete 1**.
- 6 Click  **Disable**.
- 7 Locate the **Study Extensions** section. Select the **Auxiliary sweep** checkbox.
- 8 Click  **Add**.
- 9 In the table, enter the following settings:

Parameter name	Parameter value list	Parameter unit
para (Parameter used for parametric sweep)	range(0,0.025,1)	

Solution 7 (sol7)

- 1 In the **Study** toolbar, click  **Show Default Solver**.
- 2 In the **Model Builder** window, expand the **Solution 7 (sol7)** node.
- 3 In the **Model Builder** window, expand the **Study 5 > Solver Configurations > Solution 7 (sol7) > Stationary Solver 1** node.
- 4 Right-click **Study 5 > Solver Configurations > Solution 7 (sol7) > Stationary Solver 1 > Parametric 1** and choose **Stop Condition**.
- 5 In the **Settings** window for **Stop Condition**, locate the **Stop Expressions** section.
- 6 Click  **Add**.

7 In the table, enter the following settings:

Stop expression	Stop if	Active	Description
comp1.load<-50e3	True (>=1)	√	Stop expression 1

8 Locate the **Output at Stop** section. From the **Add solution** list, choose **Step after stop**.

9 Clear the **Add information** checkbox.

10 In the **Model Builder** window, click **Study 5**.

11 In the **Settings** window for **Study**, type With Fibers in the **Label** text field.

12 In the **Study** toolbar, click  **Compute**.

RESULTS

Mirror 3D 9

1 In the **Model Builder** window, under **Results > Datasets** right-click **Mirror 3D 1** and choose **Duplicate**.

2 In the **Settings** window for **Mirror 3D**, locate the **Data** section.

3 From the **Dataset** list, choose **With Fibers/Solution 7 (sol7)**.

Mirror 3D 10

1 In the **Model Builder** window, under **Results > Datasets** right-click **Mirror 3D 2** and choose **Duplicate**.

2 In the **Settings** window for **Mirror 3D**, locate the **Data** section.

3 From the **Dataset** list, choose **Mirror 3D 9**.

Stress 5

Modify the default plots to compare the result with reinforcement bars.

1 In the **Model Builder** window, under **Results** click **Stress (solid)**.

2 In the **Settings** window for **3D Plot Group**, type Stress 5 in the **Label** text field.

3 Locate the **Plot Settings** section. Clear the **Plot dataset edges** checkbox.

4 Locate the **Data** section. From the **Dataset** list, choose **Mirror 3D 10**.

5 In the **Model Builder** window, expand the **Stress 5** node.



Volume 1

1 In the **Model Builder** window, expand the **Results > Stress 5 > Volume 1** node, then click **Volume 1**.

2 In the **Stress 5** toolbar, click  **Plot**.

Add a plot to display the stress in the embedded fibers.

RESULT TEMPLATES

- 1 In the **Results** toolbar, click  **Result Templates** to open the **Result Templates** window.
- 2 Go to the **Result Templates** window.
- 3 In the tree, select **With Fibers/Solution 7 (sol7) > Solid Mechanics > Fibers (solid) > Fiber, Linear Elastic Material 1 (solid)**.
- 4 Click the **Add Result Template** button in the window toolbar.
- 5 In the **Results** toolbar, click  **Result Templates** to close the **Result Templates** window.

RESULTS

Stress in Fibers

- 1 In the **Settings** window for **3D Plot Group**, type **Stress in Fibers** in the **Label** text field.
- 2 Locate the **Data** section. From the **Dataset** list, choose **Mirror 3D 10**.
- 3 Locate the **Plot Settings** section. Clear the **Plot dataset edges** checkbox.
- 4 Locate the **Title** section. In the **Parameter indicator** text field, type $\text{para}(10)=0.225$.

Deformation 1

- 1 In the **Model Builder** window, expand the **Stress in Fibers** node.
- 2 Right-click **Fiber 1** and choose **Deformation**.

Fiber 1

- 1 In the **Settings** window for **Streamline**, locate the **Streamline Positioning** section.
- 2 In the **Density level** text field, type 13.
- 3 Locate the **Coloring and Style** section. Find the **Line style** subsection.
- 4 Select the **Radius scale factor** checkbox. In the associated text field, type $\text{diam_bar}/2$.

Color Expression

- 1 In the **Model Builder** window, click **Color Expression**.
- 2 In the **Settings** window for **Color Expression**, locate the **Coloring and Style** section.
- 3 From the **Color table** list, choose **WaveLight**.
- 4 In the **Stress in Fibers** toolbar, click  **Plot**.

Stress 5, Stress in Fibers

- 1 In the **Model Builder** window, under **Results**, Ctrl-click to select **Stress 5** and **Stress in Fibers**.

- 2 Right-click and choose **Group**.

With Fibers

In the **Settings** window for **Group**, type **With Fibers** in the **Label** text field.

To compare the deflection of the beam for the five models like in [Figure 3](#), proceed as follows.

Deflection

- 1 In the **Results** toolbar, click  **ID Plot Group**.
- 2 In the **Settings** window for **ID Plot Group**, type **Deflection** in the **Label** text field.
- 3 Locate the **Data** section. From the **Parameter selection (para)** list, choose **Last**.
- 4 Click to expand the **Title** section. From the **Title type** list, choose **Manual**.
- 5 In the **Title** text area, type **Deflection of the beam**.
- 6 Locate the **Plot Settings** section.
- 7 Select the **x-axis label** checkbox. In the associated text field, type **Position on X-axis**.
- 8 Select the **y-axis label** checkbox. In the associated text field, type **Deflection (mm)**.
- 9 Locate the **Legend** section. From the **Position** list, choose **Lower left**.

Line Graph 1

- 1 Right-click **Deflection** and choose **Line Graph**.
- 2 In the **Settings** window for **Line Graph**, locate the **Data** section.
- 3 From the **Dataset** list, choose **Without Bars/Solution 1 (sol1)**.
- 4 From the **Parameter selection (para)** list, choose **Last**.
- 5 Select **Edge 11** only.
- 6 Locate the **y-Axis Data** section. From the **Unit** list, choose **mm**.
- 7 Click **Replace Expression** in the upper-right corner of the **y-Axis Data** section. From the menu, choose **Component 1 (comp1) > Solid Mechanics > Displacement > Displacement field - m > w - Displacement field, Z-component**.
- 8 Locate the **x-Axis Data** section. From the **Parameter** list, choose **Expression**.
- 9 In the **Expression** text field, type **X**.
- 10 Click to expand the **Coloring and Style** section. Find the **Line markers** subsection. From the **Marker** list, choose **Cycle**.
- 11 From the **Positioning** list, choose **Interpolated**.
- 12 Click to expand the **Legends** section. Select the **Show legends** checkbox.
- 13 From the **Legends** list, choose **Manual**.

14 In the table, enter the following settings:

Legends

Linear elastic model

Line Graph 2

- 1 Right-click **Line Graph 1** and choose **Duplicate**.
- 2 In the **Settings** window for **Line Graph**, locate the **Data** section.
- 3 From the **Dataset** list, choose **With Bars/Solution 2 (sol2)**.
- 4 Locate the **Legends** section. In the table, enter the following settings:

Legends

Linear elastic model with bars

Line Graph 3

- 1 In the **Model Builder** window, under **Results > Deflection** right-click **Line Graph 1** and choose **Duplicate**.
- 2 In the **Settings** window for **Line Graph**, locate the **Data** section.
- 3 From the **Dataset** list, choose **With Bars and Ottosen/Solution 3 (sol3)**.
- 4 Locate the **Legends** section. In the table, enter the following settings:

Legends

Ottosen model with bars

Line Graph 4

- 1 Right-click **Line Graph 1** and choose **Duplicate**.
- 2 In the **Settings** window for **Line Graph**, locate the **Data** section.
- 3 From the **Dataset** list, choose **With Bars and Damage/Solution 4 (sol4)**.
- 4 Locate the **Legends** section. In the table, enter the following settings:

Legends

Mazars model with bars

Line Graph 5

- 1 Right-click **Line Graph 1** and choose **Duplicate**.
- 2 In the **Settings** window for **Line Graph**, locate the **Data** section.
- 3 From the **Dataset** list, choose **With Fibers/Solution 7 (sol7)**.

4 Locate the **Legends** section. In the table, enter the following settings:

Legends

Linear elastic model with fibers

5 Locate the **Coloring and Style** section. Find the **Line markers** subsection. Set the **Number** value to **7**.

6 In the **Deflection** toolbar, click  **Plot**.

7 Click the  **Zoom Extents** button in the **Graphics** toolbar.

To compare the plastic strains in one reinforcement bar in studies 2 to 4, proceed as follows.

Plastic Strains

1 In the **Results** toolbar, click  **ID Plot Group**.

2 In the **Settings** window for **ID Plot Group**, type **Plastic Strains** in the **Label** text field.

3 Locate the **Data** section. From the **Parameter selection (para)** list, choose **Last**.

4 Locate the **Title** section. From the **Title type** list, choose **Manual**.

5 In the **Title** text area, type **Plastic strain in bars**.

6 Locate the **Plot Settings** section.

7 Select the **x-axis label** checkbox. In the associated text field, type **Position on X-axis**.

8 Select the **y-axis label** checkbox. In the associated text field, type **Plastic strains**.

9 Locate the **Legend** section. From the **Position** list, choose **Upper left**.

Line Graph 1

1 Right-click **Plastic Strains** and choose **Line Graph**.

2 In the **Settings** window for **Line Graph**, locate the **Data** section.

3 From the **Dataset** list, choose **With Bars/Solution 2 (sol2)**.

4 From the **Parameter selection (para)** list, choose **Last**.

5 Click the  **Wireframe Rendering** button in the **Graphics** toolbar.

6 Select **Edge 29** only.

7 Click the  **Wireframe Rendering** button in the **Graphics** toolbar.

8 Click **Replace Expression** in the upper-right corner of the **y-Axis Data** section. From the menu, choose **Component 1 (comp1) > Truss > Strain > truss.epnGp - Plastic axial strain - 1**.

9 Locate the **x-Axis Data** section. From the **Parameter** list, choose **Expression**.

- 10 In the **Expression** text field, type *X*.
- 11 From the **Unit** list, choose **mm**.
- 12 Locate the **Legends** section. Select the **Show legends** checkbox.
- 13 From the **Legends** list, choose **Manual**.
- 14 In the table, enter the following settings:

Legends
Linear elastic model with bars

Line Graph 2



- 1 Right-click **Line Graph 1** and choose **Duplicate**.
- 2 In the **Settings** window for **Line Graph**, locate the **Data** section.
- 3 From the **Dataset** list, choose **With Bars and Ottosen/Solution 3 (sol3)**.
- 4 Locate the **Legends** section. In the table, enter the following settings:

Legends
Ottosen model with bars

Line Graph 3

- 1 In the **Model Builder** window, under **Results > Plastic Strains** right-click **Line Graph 1** and choose **Duplicate**.
- 2 In the **Settings** window for **Line Graph**, locate the **Data** section.
- 3 From the **Dataset** list, choose **With Bars and Damage/Solution 4 (sol4)**.
- 4 Locate the **Legends** section. In the table, enter the following settings:

Legends
Mazars model with bars

- 5 In the **Plastic Strains** toolbar, click  **Plot**.
- 6 Click the  **Zoom Extents** button in the **Graphics** toolbar.

To compare the load versus deflection curves of the five models ([Figure 15](#)), proceed as follows.

Load vs. Deflection

- 1 In the **Results** toolbar, click  **ID Plot Group**.
- 2 In the **Settings** window for **ID Plot Group**, type **Load vs. Deflection** in the **Label** text field.

- 3 Locate the **Title** section. From the **Title type** list, choose **Manual**.
- 4 In the **Title** text area, type Load vs. Deflection.
- 5 Locate the **Plot Settings** section.
- 6 Select the **x-axis label** checkbox. In the associated text field, type Deflection (mm).
- 7 Select the **y-axis label** checkbox. In the associated text field, type Load (kN/m²).
- 8 Locate the **Legend** section. From the **Position** list, choose **Lower right**.

Global 1

- 1 Right-click **Load vs. Deflection** and choose **Global**.
- 2 In the **Settings** window for **Global**, locate the **Data** section.
- 3 From the **Dataset** list, choose **Without Bars/Solution 1 (sol1)**.
- 4 Locate the **y-Axis Data** section. In the table, enter the following settings:

Expression	Unit	Description
-load	kN/m ²	Linear elastic model

- 5 Locate the **x-Axis Data** section. From the **Parameter** list, choose **Expression**.
- 6 In the **Expression** text field, type -intop1(w).
- 7 From the **Unit** list, choose **mm**.
- 8 Click to expand the **Coloring and Style** section.

Global 2

- 1 Right-click **Global 1** and choose **Duplicate**.
- 2 In the **Settings** window for **Global**, locate the **Data** section.
- 3 From the **Dataset** list, choose **With Bars/Solution 2 (sol2)**.
- 4 Locate the **y-Axis Data** section. In the table, enter the following settings:

Expression	Unit	Description
-load	kN/m ²	Linear elastic model with bars

Global 3

- 1 In the **Model Builder** window, under **Results > Load vs. Deflection** right-click **Global 1** and choose **Duplicate**.
- 2 In the **Settings** window for **Global**, locate the **Data** section.
- 3 From the **Dataset** list, choose **With Bars and Ottosen/Solution 3 (sol3)**.

4 Locate the **y-Axis Data** section. In the table, enter the following settings:

Expression	Unit	Description
-load	kN/m ²	Ottosen model with bars

Global 4



- 1 Right-click **Global 1** and choose **Duplicate**.
- 2 In the **Settings** window for **Global**, locate the **Data** section.
- 3 From the **Dataset** list, choose **With Bars and Damage/Solution 4 (sol4)**.
- 4 Locate the **y-Axis Data** section. In the table, enter the following settings:

Expression	Unit	Description
-load	kN/m ²	Mazars model with bars

Global 5

- 1 Right-click **Global 1** and choose **Duplicate**.
- 2 In the **Settings** window for **Global**, locate the **Data** section.
- 3 From the **Dataset** list, choose **With Fibers/Solution 7 (sol7)**.
- 4 Locate the **y-Axis Data** section. In the table, enter the following settings:

Expression	Unit	Description
-load	kN/m ²	Linear elastic model with fibers

- 5 In the **Load vs. Deflection** toolbar, click  **Plot**.
- 6 Click the  **Zoom Extents** button in the **Graphics** toolbar.
Disable Mazars damage in the first three studies and the fibers in the first four studies to make them still runnable.



WITHOUT BARS

Step 1: Stationary



- 1 In the **Model Builder** window, under **Without Bars** click **Step 1: Stationary**.
- 2 In the **Settings** window for **Stationary**, locate the **Physics and Variables Selection** section.
- 3 In the tree, select **Component 1 (comp1) > Solid Mechanics (solid) > Linear Elastic Material 1 > Concrete 2**.
- 4 Click  **Disable**.
- 5 In the tree, select **Component 1 (comp1) > Solid Mechanics (solid) > Linear Elastic Material 1 > Fiber 1**.

6 Click  **Disable**.

WITH BARS

- 1 In the **Model Builder** window, under **With Bars** click **Step 1: Stationary**.
- 2 In the **Settings** window for **Stationary**, locate the **Physics and Variables Selection** section.
- 3 In the tree, select **Component 1 (comp1) > Solid Mechanics (solid) > Linear Elastic Material 1 > Concrete 2**.
- 4 Click  **Disable**.
- 5 In the tree, select **Component 1 (comp1) > Solid Mechanics (solid) > Linear Elastic Material 1 > Fiber 1**.
- 6 Click  **Disable**.

WITH BARS AND OTTOSEN

- 1 In the **Model Builder** window, under **With Bars and Ottosen** click **Step 1: Stationary**.
- 2 In the **Settings** window for **Stationary**, locate the **Physics and Variables Selection** section.
- 3 Select the **Modify model configuration for study step** checkbox.
- 4 In the tree, select **Component 1 (comp1) > Solid Mechanics (solid) > Linear Elastic Material 1 > Concrete 2**.
- 5 Click  **Disable**.
- 6 In the tree, select **Component 1 (comp1) > Solid Mechanics (solid) > Linear Elastic Material 1 > Fiber 1**.
- 7 Click  **Disable**.

WITH BARS AND DAMAGE

- 1 In the **Model Builder** window, under **With Bars and Damage** click **Step 1: Stationary**.
- 2 In the **Settings** window for **Stationary**, locate the **Physics and Variables Selection** section.
- 3 In the tree, select **Component 1 (comp1) > Solid Mechanics (solid) > Linear Elastic Material 1 > Fiber 1**.
- 4 Click  **Disable**.