



Model created in COMSOL Multiphysics 6.4

Two-Phase Nonisothermal Zero-Gap Alkaline Water Electrolyzer

Introduction

This model defines a zero-gap alkaline water electrolyzer, where oxygen and hydrogen gas are evolved in porous gas diffusion nickel felt electrodes, placed adjacent to a porous separator (diaphragm).

The geometry defines a unit cell of an electrolyzer stack, in turn comprising two full electrolyzer cells, extending 10 cm along the channel direction. The two electrolyzer cells are separated by a corrugated bipolar steel plate.

The model solves for the fully intercoupled current distribution of the electrolyzer cells, two-phase flow of evolved gases and electrolyte, and heat transfer.

The model is advanced and uses several coupled physics interfaces. For new users, it is recommended to first study the [Mass Transport and Electrochemical Reaction in a Fuel Cell Cathode](#) and [Fuel Cell Cathode with Liquid Water](#) tutorial examples.

Model Definition

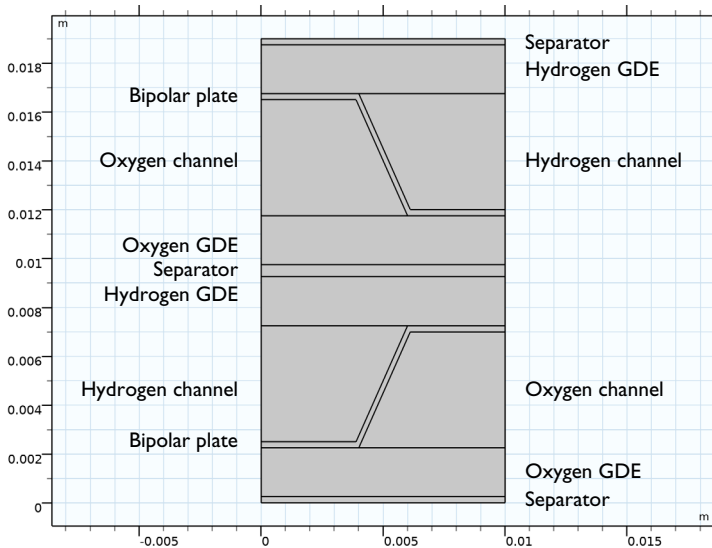

Figure 1: 2D-cross section of the two-cell unit cell.

Figure 1 shows a cross section of the model geometry, defining a two-cell unit cell within an electrolyzer stack. Each cell consists of a hydrogen electrolyte compartment, and an

oxygen electrolyte compartment, separated by a bipolar steel plate and a separator (diaphragm). The 2 mm thick gas diffusion electrodes (GDEs) consist of porous nickel felt.

The cross section is extruded to form the 3D geometry as shown in [Figure 2](#). The cell has a length of 10 cm, with additional 6 mm extrusions of the flow channels at the oxygen and hydrogen inlets and outlets.

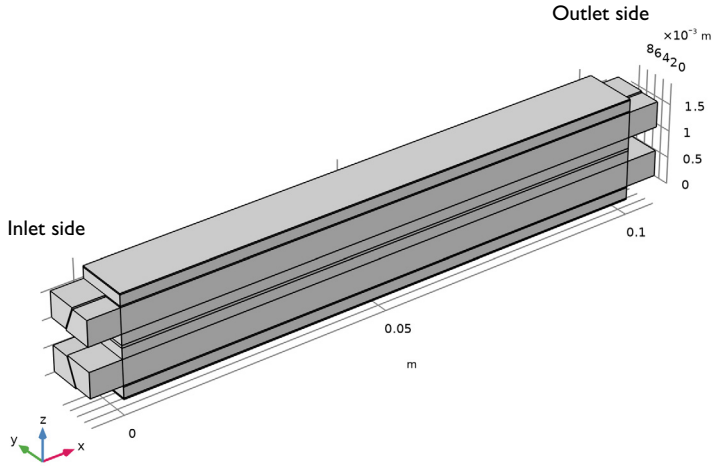

Figure 2: Extruded 3D geometry.

VOLUME FRACTIONS

The **Phase Transport in Free and Porous Media interface** solves for the relative gas volume fraction s_g in the gas–electrolyte mixture. The relative liquid volume fraction is defined as

$$s_l = 1 - s_g$$

As gas is evolved in the electrodes and transported out to the gas–electrolyte channels, the volume fraction of electrolyte decreases, making room for the evolved gas.

In the GDEs, the electrolyte volume fraction ϵ_l is defined as

$$\epsilon_l = s_l \epsilon_{\text{por}}$$

where ϵ_{por} is the pore volume fraction relative to the total volume.

In the gas–electrolyte channels, the electrolyte volume fraction is defined as

$$\varepsilon_1 = s_1$$

MATERIAL PROPERTIES

The material properties for the steel bipolar plate and the 5 M KOH electrolyte are retrieved from the **Built-in** and **Fuel Cell & Electrolyzer** material libraries, respectively. User-defined values for the nickel felt GDEs are specified in a **Parameters** node. The Water and Electrolyzer interface is used to calculate the properties of the fully humidified H₂ and O₂ gas mixtures.

Volume-averaged properties, based on s_g and s_1 , are used for the thermal conductivity, density and heat capacity of the gas–electrolyte mixture. These properties are defined on the GDE and channel domains by the use of **Variables** nodes.

WATER ELECTROLYZER INTERFACE

The current distribution and electrochemical reactions are defined using the **Water Electrolyzer** interface. The porous gas diffusion electrodes are modeled using Butler–Volmer kinetics. Ohmic losses in the electrode and electrolyte phases are included. Gas transport of the gas phase as a whole is included in the model, but any effects due to partial pressure gradients of the different species in the gas phase are neglected.

The effective electrolyte conductivity in the electrolyte compartment, GDEs, and the separator is set to depend on the electrolyte volume fraction according to

$$\sigma_{1, \text{eff}} = \varepsilon_1^{3/2} \sigma_{1, \text{bulk}} \quad (1)$$

where $\sigma_{1, \text{bulk}}$ is the bulk conductivity of 6 M KOH.

The cell voltage of the two-cell unit cell is set by the offset in the periodic condition (see the section below). Also, an electrolyte phase point condition is added in order to ground the model and ensure a unique solution for the potential variables.

MULTIPHASE FLOW IN FREE AND POROUS MEDIA MULTIPHYSICS INTERFACE

The two-phase flow model is defined by adding a **Multiphase Flow in Free and Porous Media** multiphysics interface to the model. This in turn adds the following physics interfaces to the model tree:

- **Darcy's Law**, solving for the liquid pressure in the GDEs

- **Laminar Flow**, solving for the liquid pressure and velocity field in the channels
- **Phase Transport**, solving for the gas phase volume fraction in the gas-liquid two-phase mixture

In addition, the following multiphysics nodes are also added by **Multiphase Flow in Free and Porous Media**:

- **Multiphase Flow in Porous Media**, coupling Darcy's law and Phase Transport in the GDEs
- **Free and Porous Media Flow Coupling**, defining the boundary between the Laminar Flow and Darcy's Law domains
- **Mixture Model**, coupling Laminar Flow and Phase Transport in the channels

The gas and liquid mass sources, stemming from the electrode reactions defined by the Water Electrolyzer interface, are added as a **Mass Source** node in the Phase Transport interface. **Turbulent Mixing** is added in the channels to the Phase Transport interface in order to facilitate convergence.

Fully-developed flow conditions are defined on a common **Inlet** node in the Laminar Flow interface, with an average velocity of 1 cm/s set for all channels. A uniform outlet pressure of 25 atm is defined on the **Outlet** node in the same interface.

HEAT TRANSFER IN SOLIDS AND FLUIDS INTERFACE

Solid (bipolar plate), **Fluid** (channels) and **Porous Medium** (GDE and separator) nodes are used to define the heat transfer in the cell.

The heat sources related to the electrochemical reactions are added to the Heat Transfer interface by the use of an **Electrochemical Heating** multiphysics nodes.

The inlet temperature of the cell is set to 80°C.

PERIODIC CONDITIONS

Periodicity between the topmost and bottommost separator boundaries in [Figure 1](#) is defined by the use of a **Periodic Condition** node in Heat Transfer, which sets both the ingoing and outgoing heat fluxes, as well as the temperature, equal at the matching positions at the two boundaries. In the Water Electrolyzer interface, a periodic condition for the electrolyte phase potential is set up manually by the use of a **Linear Extrusion** operator, which also includes a potential offset of two times the cell voltage for the two-cell unit cell.

STUDY

Three consecutive study steps are used to solve the problem. For each step, the solution of the dependent variables solved for in the previous step are passed on as the corresponding initial values to the subsequent step.

A first **Current Distribution Initialization** step computes suitable initial values for the electrode and electrolyte phase potentials of the Water Electrolyzer interface. A second **Stationary** step then solves for the pressures and velocity fields of the Darcy's Law and Laminar Flow interfaces only. The third and final step solves for the fully coupled problem, ramping up the cell voltage from 1.5 to 2.1 V using an **Auxiliary Sweep**.

Results and Discussion

Figure 3 shows the polarization plot generated by the auxiliary sweep.

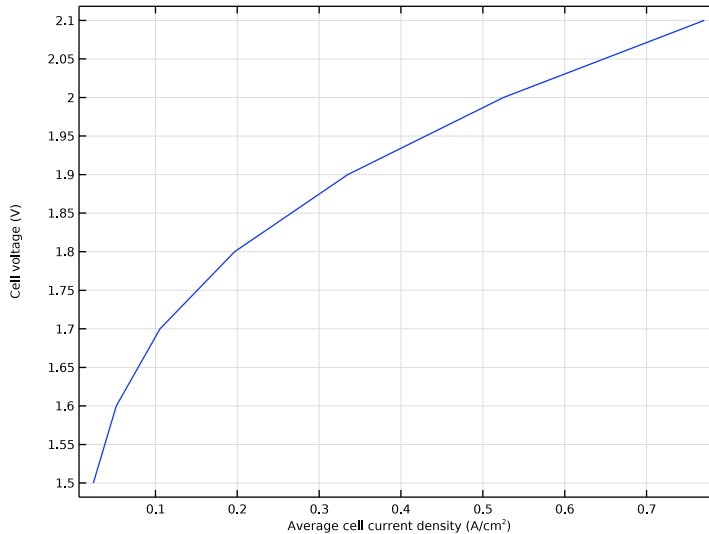

Figure 3: Polarization.

Figure 4 shows the electrolyte phase potential in the channels and GDEs for a cell voltage of 2.1 V, whereas Figure 5 shows the electrode phase potential in the GDEs and bipolar plates for the same cell potential.

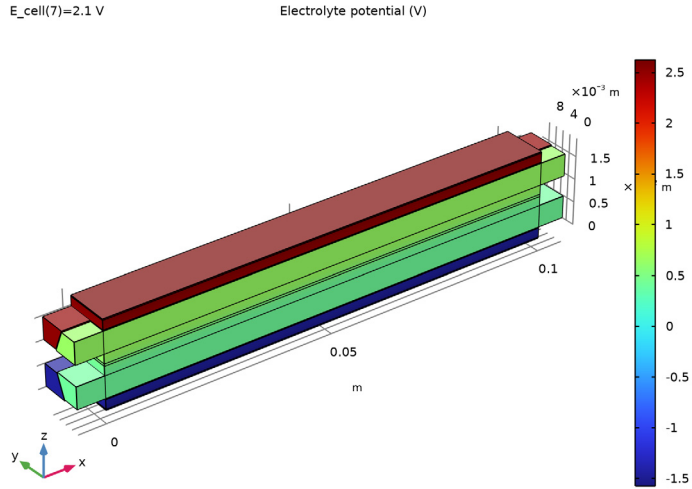

Figure 4: Electrolyte phase potential.

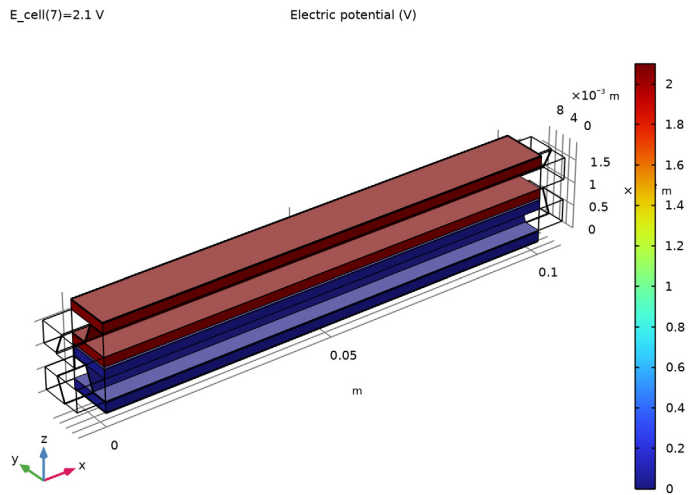

Figure 5: Electrode phase potential.

Figure 6 and Figure 7 show the gas volume fraction of the gas-electrolyte mixture in the GDEs and the channels, respectively, whereas Figure 8 shows the corresponding streamlines in the channels.

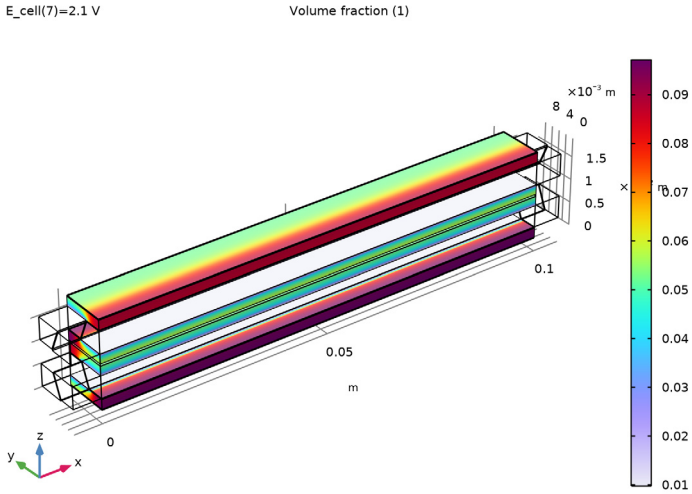

Figure 6: Gas volume fraction in the fluid mixture in the GDEs.

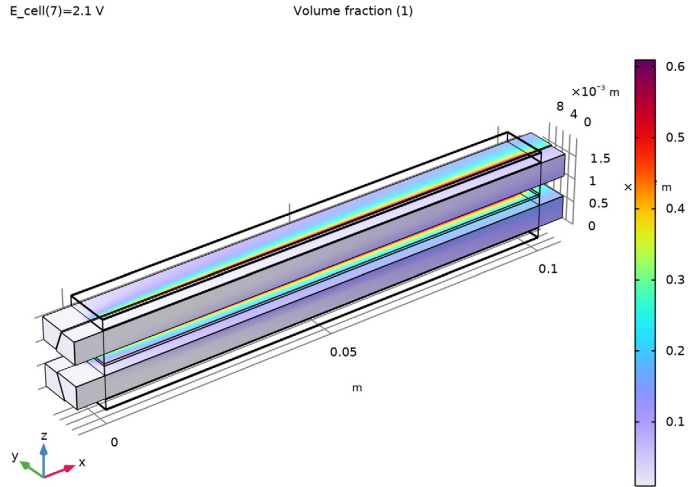

Figure 7: Gas volume fraction in the channels.

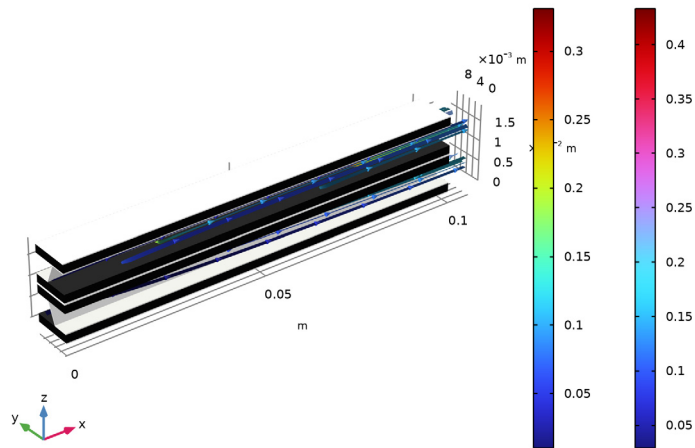

Figure 8: Gas streamlines and gas volume fraction.

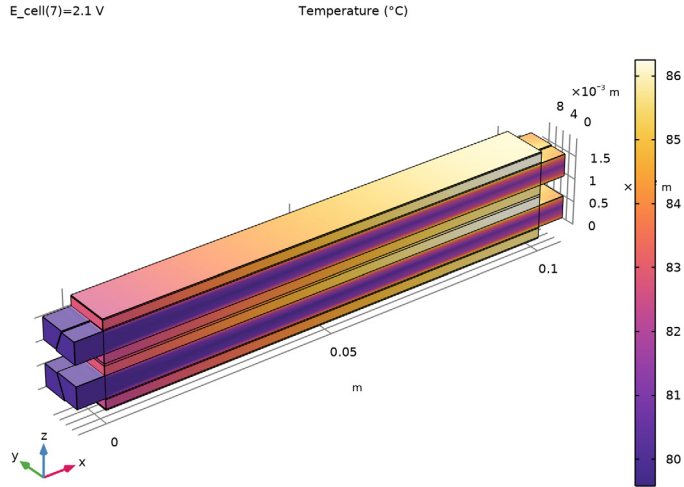

Figure 9: Temperature.

Figure 9 shows a plot of the temperature. The temperature increases toward the outlets.

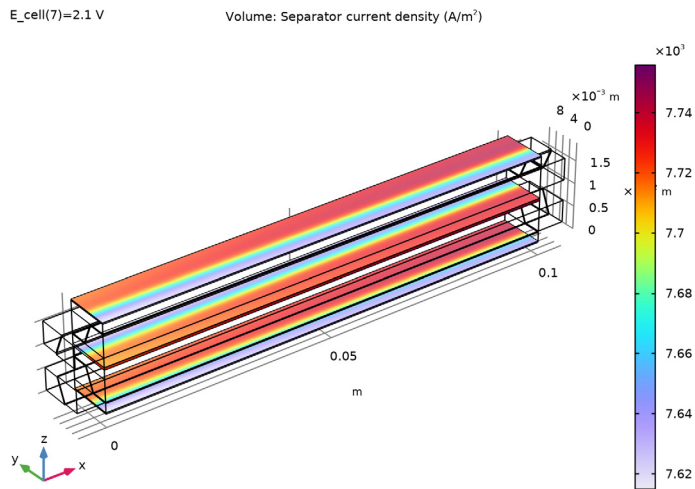

Figure 10: Separator current density.

Figure 10 shows a plot of the separator current density. The separator current density increases slightly toward the outlet of the cell. This is mainly an effect due to the increased temperature toward the outlet, which slightly lowers the cell equilibrium potential for electrolyzing water.

Application Library path: Fuel_Cell_and_Electrolyzer_Module/Electrolyzers/zero_gap_aec



Modeling Instructions

From the **File** menu, choose **New**.

NEW

In the **New** window, click  **Model Wizard**.

MODEL WIZARD

- 1 In the **Model Wizard** window, click  **3D**.
- 2 In the **Select Physics** tree, select **Electrochemistry > Water Electrolyzers > Alkaline (we)**.
- 3 Click **Add**.
- 4 In the **Select Physics** tree, select **Fluid Flow > Porous Media and Subsurface Flow > Multiphase Free and Porous Media Flow**.
- 5 Click **Add**.
- 6 In the **Select Physics** tree, select **Heat Transfer > Heat Transfer in Solids and Fluids (ht)**.
- 7 Click **Add**.
- 8 Click  **Study**.
- 9 In the **Select Study** tree, select **Preset Studies for Selected Physics Interfaces > Water Electrolyzer > Stationary with Initialization**.
- 10 Click  **Done**.

GEOMETRY I

Insert the geometry sequence from a file as follows:

- 1 In the **Geometry** toolbar, click **Insert Sequence** and choose **Insert Sequence**.
- 2 Browse to the model's Application Libraries folder and double-click the file zero_gap_aec_geom_sequence.mph.

- 3 In the **Geometry** toolbar, click  **Build All**.
- 4 In the **Model Builder** window, under **Component 1 (comp1)** click **Geometry 1**.

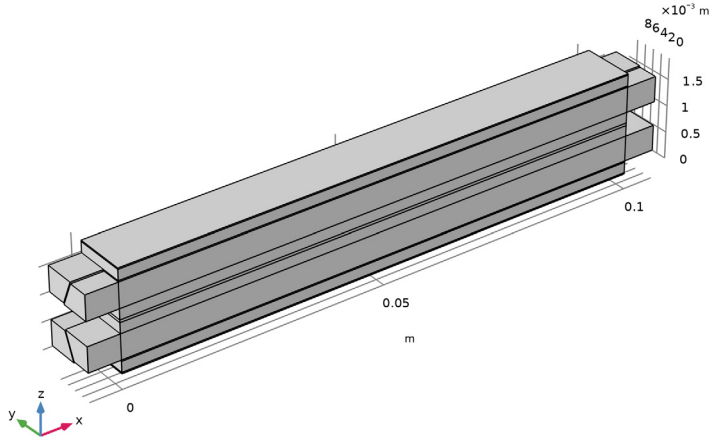

- 5 In the **Model Builder** window, collapse the **Geometry 1** node.

GLOBAL DEFINITIONS

Geometry Parameters

The geometry sequence you imported uses a number of parameters, which now appear in a **Parameters** node.

- 1 In the **Model Builder** window, under **Global Definitions** click **Parameters 1**.
- 2 In the **Settings** window for **Parameters**, type Geometry Parameters in the **Label** text field.

Physics Parameters

Add a second **Parameters** node for the physics parameters.

- 1 In the **Home** toolbar, click  **Parameters** and choose **Add > Parameters**.
- 2 In the **Settings** window for **Parameters**, type Physics Parameters in the **Label** text field.

Import the physics parameters from a text file.

- 3 Locate the **Parameters** section. Click  **Load from File**.

- 4 Browse to the model's Application Libraries folder and double-click the file `zero_gap_aec_physics_parameters.txt`.

MATERIALS

Add some material data from the material libraries as follows:

ADD MATERIAL

- 1 In the **Materials** toolbar, click  **Add Material** to open the **Add Material** window.
- 2 Go to the **Add Material** window.
- 3 In the tree, select **Built-in > Steel AISI 4340**.
- 4 Right-click and choose **Add to Component 1 (comp1)**.

MATERIALS

Steel AISI 4340 (mat1)

- 1 In the **Model Builder** window, under **Component 1 (comp1) > Materials** click **Steel AISI 4340 (mat1)**.
- 2 In the **Settings** window for **Material**, locate the **Geometric Entity Selection** section.
- 3 From the **Selection** list, choose **Bipolar Plates**.

ADD MATERIAL

- 1 Go to the **Add Material** window.
- 2 In the tree, select **Fuel Cell and Electrolyzer > Aqueous Alkali > Potassium Hydroxide, KOH**.
- 3 Right-click and choose **Add to Component 1 (comp1)**.
- 4 In the **Materials** toolbar, click  **Add Material** to close the **Add Material** window.

MATERIALS

Potassium Hydroxide, KOH (mat2)

- 1 In the **Settings** window for **Material**, locate the **Geometric Entity Selection** section.
- 2 From the **Selection** list, choose **Electrolyte Domains**.

DEFINITIONS

Now add a number of **Variables** nodes. Note that the different nodes have different domain selections. In this way variables with the same name can be defined differently in different domains.

Variables - GDEs

- 1 In the **Model Builder** window, under **Component 1 (comp1)** right-click **Definitions** and choose **Variables**.
- 2 In the **Settings** window for **Variables**, type `Variables - GDEs` in the **Label** text field.
- 3 Locate the **Geometric Entity Selection** section. From the **Geometric entity level** list, choose **Domain**.
- 4 From the **Selection** list, choose **GDEs**.
- 5 Locate the **Variables** section. Click  **Load from File**.
- 6 Browse to the model's Application Libraries folder and double-click the file `zero_gap_aec_gde_variables.txt`.

Variables - Channels

- 1 In the **Model Builder** window, right-click **Definitions** and choose **Variables**.
- 2 In the **Settings** window for **Variables**, type `Variables - Channels` in the **Label** text field.
- 3 Locate the **Geometric Entity Selection** section. From the **Geometric entity level** list, choose **Domain**.
- 4 From the **Selection** list, choose **Channels**.
- 5 Locate the **Variables** section. Click  **Load from File**.
- 6 Browse to the model's Application Libraries folder and double-click the file `zero_gap_aec_channel_variables.txt`.

Some variable expressions you imported are indicating missing variable definitions. Change the name of the dependent variables in the phase transport interface in order to fix some of these issues.

PHASE TRANSPORT IN FREE AND POROUS MEDIA FLOW (PHTR)

- 1 In the **Model Builder** window, under **Component 1 (comp1)** click **Phase Transport in Free and Porous Media Flow (phtr)**.
- 2 In the **Settings** window for **Phase Transport in Free and Porous Media Flow**, click to expand the **Dependent Variables** section.

3 In the **Volume fractions (1)** table, enter the following settings:

s_l

s_g

In this model s_l denotes the volume fraction of the liquid phase, and s_g denotes the volume fraction of the gas phase.

WATER ELECTROLYZER (WE)

Now start setting up the **Water Electrolyzer** physics interface. This interface will solve for the electrolyte and electrode phase potentials, and will define the properties of the gas phase.

- 1 In the **Model Builder** window, under **Component 1 (comp1)** click **Water Electrolyzer (we)**.
- 2 In the **Settings** window for **Water Electrolyzer**, locate the **H2 Gas Mixture** section.
- 3 Find the **Transport mechanisms** subsection. Clear the **Include gas phase diffusion** checkbox.
- 4 Locate the **O2 Gas Mixture** section. Clear the **Include gas phase diffusion** checkbox.

Current Collector 1

- 1 In the **Physics** toolbar, click  **Domains** and choose **Current Collector**.
- 2 In the **Settings** window for **Current Collector**, locate the **Domain Selection** section.
- 3 From the **Selection** list, choose **Bipolar Plates**.
- 4 Locate the **Electrode Charge Transport** section. From the σ_s list, choose **From material**.

H2 Gas-Electrolyte Compartment 1

- 1 In the **Physics** toolbar, click  **Domains** and choose **H2 Gas-Electrolyte Compartment**.
- 2 In the **Settings** window for **H2 Gas-Electrolyte Compartment**, locate the **Domain Selection** section.
- 3 From the **Selection** list, choose **Hydrogen Channels**.
- 4 Locate the **Effective Electrolyte Charge Transport** section. In the ϵ_1 text field, type `eps1`.

H2 Gas Diffusion Electrode 1

- 1 In the **Physics** toolbar, click  **Domains** and choose **H2 Gas Diffusion Electrode**.
- 2 In the **Settings** window for **H2 Gas Diffusion Electrode**, locate the **Domain Selection** section.
- 3 From the **Selection** list, choose **Hydrogen GDEs**.
- 4 Locate the **Electrode Charge Transport** section. In the σ_g text field, type `sigma_Ni_eff`.

5 Locate the **Effective Electrolyte Charge Transport** section. In the ϵ_1 text field, type eps1.

H2 Gas Diffusion Electrode Reaction I

- 1 In the **Model Builder** window, click **H2 Gas Diffusion Electrode Reaction I**.
- 2 In the **Settings** window for **H2 Gas Diffusion Electrode Reaction**, locate the **Stoichiometric Coefficients** section.
- 3 In the $v_{\text{H}_2\text{O}}$ text field, type 0.
- 4 In the $v_{\text{H}_2\text{O(l)}}$ text field, type -1.
- 5 Locate the **Electrode Kinetics** section. In the $i_{0,\text{ref}}(T)$ text field, type i0_ref_her.
- 6 Locate the **Active Specific Surface Area** section. In the a_v text field, type Av.

Separator I

- 1 In the **Physics** toolbar, click  **Domains** and choose **Separator**.
- 2 In the **Settings** window for **Separator**, locate the **Domain Selection** section.
- 3 From the **Selection** list, choose **Separators**.
- 4 Locate the **Effective Electrolyte Charge Transport** section. In the ϵ_1 text field, type eps1_sep.

O2 Gas Diffusion Electrode I

- 1 In the **Physics** toolbar, click  **Domains** and choose **O2 Gas Diffusion Electrode**.
- 2 In the **Settings** window for **O2 Gas Diffusion Electrode**, locate the **Domain Selection** section.
- 3 From the **Selection** list, choose **Oxygen GDEs**.
- 4 Locate the **Electrode Charge Transport** section. In the σ_s text field, type sigma_Ni_eff.
- 5 Locate the **Effective Electrolyte Charge Transport** section. In the ϵ_1 text field, type eps1.

O2 Gas Diffusion Electrode Reaction I

- 1 In the **Model Builder** window, click **O2 Gas Diffusion Electrode Reaction I**.
- 2 In the **Settings** window for **O2 Gas Diffusion Electrode Reaction**, locate the **Stoichiometric Coefficients** section.
- 3 In the $v_{\text{H}_2\text{O}}$ text field, type 0.
- 4 In the $v_{\text{H}_2\text{O(l)}}$ text field, type -1.
- 5 Locate the **Electrode Kinetics** section. In the $i_{0,\text{ref}}(T)$ text field, type i0_ref_oer.
- 6 From the **Edit** menu, choose **Undo O2 Gas Diffusion Electrode Reaction I: Reference Exchange Current Density**.
- 7 Locate the **Active Specific Surface Area** section. In the a_v text field, type Av.

O2 Gas-Electrolyte Compartment I

- 1 In the **Physics** toolbar, click  **Domains** and choose **O2 Gas-Electrolyte Compartment**.
- 2 In the **Settings** window for **O2 Gas-Electrolyte Compartment**, locate the **Domain Selection** section.
- 3 From the **Selection** list, choose **Oxygen Channels**.
- 4 Locate the **Effective Electrolyte Charge Transport** section. In the ϵ_1 text field, type eps1.

H2 Gas Phase I

- 1 In the **Model Builder** window, click **H2 Gas Phase I**.
- 2 In the **Settings** window for **H2 Gas Phase**, locate the **Model Input** section.
- 3 From the p_A list, choose **User defined**. In the associated text field, type pA_gas .
- 4 Locate the **Composition** section. From the **Mixture specification** list, choose **Humidified mixture**.
- 5 In the T_{hum} text field, type T.
- 6 In the $p_{A,hum}$ text field, type pA_gas .
- 7 Locate the **Water Vapor Pressure** section. From the p_{vap} list, choose **From material**.
- 8 From the H_{vap} list, choose **From material**.

O2 Gas Phase I

- 1 In the **Model Builder** window, click **O2 Gas Phase I**.
- 2 In the **Settings** window for **O2 Gas Phase**, locate the **Model Input** section.
- 3 From the p_A list, choose **User defined**. In the associated text field, type pA_gas .
- 4 Locate the **Composition** section. From the **Mixture specification** list, choose **Humidified mixture**.
- 5 In the T_{hum} text field, type T.
- 6 In the $p_{A,hum}$ text field, type pA_gas .
- 7 Locate the **Water Vapor Pressure** section. From the p_{vap} list, choose **From material**.
- 8 From the H_{vap} list, choose **From material**.

Periodic Condition I

The model defines a two-cell unit-cell, assuming symmetry and periodic conditions on all external boundaries parallel to the xy and xz -planes.

- 1 In the **Physics** toolbar, click  **Boundaries** and choose **Periodic Condition**.
- 2 Select Boundaries 23 and 54 only.
- 3 In the **Settings** window for **Periodic Condition**, locate the **Periodic Condition** section.

- 4 In the $\phi_{1,src} - \phi_{1,dst}$ text field, type $-2 * E_{cell}$.
- 5 Clear the **Apply for electronic conducting phase** checkbox.

Electronic Conducting Phase I

The potentials need to be grounded somewhere in the model (otherwise no unique solution for the potentials exists). Use a point feature Electric Ground to ground the electrode phase potential.

In the **Model Builder** window, click **Electronic Conducting Phase I**.

Electric Ground I

- 1 In the **Physics** toolbar, click  **Attributes** and choose **Electric Ground**.
- 2 Select Point 19 only.
- 3 In the **Model Builder** window, collapse the **Water Electrolyzer (we)** node.

LAMINAR FLOW (SPF)

The electrolyzer settings are now complete. Now set up the flow interfaces, starting with the laminar flow in the electrolyte-gas channels.

- 1 In the **Model Builder** window, under **Component 1 (comp1)** click **Laminar Flow (spf)**.
- 2 In the **Settings** window for **Laminar Flow**, locate the **Domain Selection** section.
- 3 From the **Selection** list, choose **Channels**.
- 4 Locate the **Physical Model** section. In the p_{ref} text field, type p_{out} .

Fluid Properties I

- 1 In the **Model Builder** window, under **Component 1 (comp1)** > **Laminar Flow (spf)** click **Fluid Properties I**.
- 2 In the **Settings** window for **Fluid Properties**, locate the **Model Input** section.
- 3 From the c list, choose **Common model input**.

Inlet I

- 1 In the **Physics** toolbar, click  **Boundaries** and choose **Inlet**.
- 2 In the **Settings** window for **Inlet**, locate the **Boundary Selection** section.
- 3 From the **Selection** list, choose **Inlets**.
- 4 Locate the **Boundary Condition** section. From the list, choose **Fully developed flow**.
- 5 Locate the **Fully Developed Flow** section. In the U_{av} text field, type v_{in} .

Outlet I

- 1 In the **Physics** toolbar, click  **Boundaries** and choose **Outlet**.

- 2 In the **Settings** window for **Outlet**, locate the **Boundary Selection** section.
- 3 From the **Selection** list, choose **Outlets**.

Symmetry I

- 1 In the **Physics** toolbar, click  **Boundaries** and choose **Symmetry**.
- 2 Select Boundaries 2, 6, 19, 20, 31, 43, 69, 75, 82, 89, 105, and 106 only.
- 3 In the **Model Builder** window, collapse the **Laminar Flow (spf)** node.

DARCY'S LAW (DL)

Now set up the **Darcy's Law** interface, which defines the flow in the porous gas diffusion electrodes.

- 1 In the **Model Builder** window, under **Component 1 (comp1)** click **Darcy's Law (dl)**.
- 2 In the **Settings** window for **Darcy's Law**, locate the **Domain Selection** section.
- 3 From the **Selection** list, choose **GDEs**.
- 4 Locate the **Physical Model** section. In the p_{ref} text field, type p_{out} .
- 5 Click to expand the **Discretization** section. From the **Pressure** list, choose **Linear**.

Porous Matrix I

- 1 In the **Model Builder** window, under **Component 1 (comp1) > Darcy's Law (dl) > Porous Medium 1** click **Porous Matrix 1**.
- 2 In the **Settings** window for **Porous Matrix**, locate the **Matrix Properties** section.
- 3 From the ϵ_p list, choose **User defined**. In the associated text field, type eps_pores .
- 4 From the κ list, choose **User defined**. In the associated text field, type $perm_GDE$.
- 5 In the **Model Builder** window, collapse the **Darcy's Law (dl)** node.

PHASE TRANSPORT IN FREE AND POROUS MEDIA FLOW (PHTR)

Now set up the **Phase Transport** interface, which solves for the volume fraction of the gases in the gas diffusion electrodes and the gas-electrolyte channels.

- 1 In the **Model Builder** window, under **Component 1 (comp1)** click **Phase Transport in Free and Porous Media Flow (phtr)**.
- 2 In the **Settings** window for **Phase Transport in Free and Porous Media Flow**, locate the **Domain Selection** section.
- 3 From the **Selection** list, choose **Channels and GDEs**.

Fluid 1

- 1 In the **Model Builder** window, under **Component 1 (comp1)** > **Phase Transport in Free and Porous Media Flow (phtr)** click **Fluid 1**.
- 2 In the **Settings** window for **Fluid**, locate the **Model Input** section.
- 3 From the c list, choose **Common model input**.

Turbulent Mixing 1

- 1 In the **Physics** toolbar, click  **Attributes** and choose **Turbulent Mixing**.

The turbulent mixing is needed make the evolved gas move away from the gde-channel interface and to achieve convergence. The parameter values used for turbulent mixing should be regarded as empirical tuning parameters for this very model.

- 2 In the **Settings** window for **Turbulent Mixing**, locate the **Turbulent Mixing Parameters** section.
- 3 In the v_T text field, type $1e-6$.
- 4 In the Sc_T text field, type 1 .

Porous Medium 1

- 1 In the **Model Builder** window, under **Component 1 (comp1)** > **Phase Transport in Free and Porous Media Flow (phtr)** click **Porous Medium 1**.
- 2 In the **Settings** window for **Porous Medium**, locate the **Domain Selection** section.
- 3 From the **Selection** list, choose **GDEs**.

Fluid 1

- 1 In the **Model Builder** window, click **Fluid 1**.
- 2 In the **Settings** window for **Fluid**, locate the **Model Input** section.
- 3 From the c list, choose **Common model input**.
- 4 Locate the **Capillary Pressure** section. In the p_{csg} text field, type dpc_dsg*s_g .
- 5 Locate the **Phase 1 Properties** section. From the **Fluid s_1** list, choose **Potassium Hydroxide, KOH (mat2)**.
- 6 In the text field, type s_1^2 .
- 7 Locate the **Phase 2 Properties** section. From the ρ_{sg} list, choose **Density of gas phase (we)**.
- 8 From the μ_{sg} list, choose **Dynamic viscosity of gas phase (we)**.
- 9 In the text field, type s_g^2 .

Initial Values I

- 1 In the **Model Builder** window, under **Component 1 (comp1)** > **Phase Transport in Free and Porous Media Flow (phtr)** click **Initial Values I**.
- 2 In the **Settings** window for **Initial Values**, locate the **Initial Values** section.
- 3 In the $s_{0,sg}$ text field, type s_{g_in} .

Free-Porous Interface I

- 1 In the **Model Builder** window, click **Free-Porous Interface I**.
- 2 In the **Settings** window for **Free-Porous Interface**, locate the **Phase 2** section.
- 3 From the **Boundary condition** list, choose **Outflow, no flux below threshold saturation**.
- 4 In the $s_{0,sg}$ text field, type s_{g_in} .

Volume Fraction I

- 1 In the **Physics** toolbar, click  **Boundaries** and choose **Volume Fraction**.
- 2 In the **Settings** window for **Volume Fraction**, locate the **Boundary Selection** section.
- 3 From the **Selection** list, choose **Inlets**.
- 4 Locate the **Volume Fraction** section. Select the **Phase s_g** checkbox.
- 5 In the $s_{0,sg}$ text field, type s_{g_in} .

Outflow I

- 1 In the **Physics** toolbar, click  **Boundaries** and choose **Outflow**.
- 2 In the **Settings** window for **Outflow**, locate the **Boundary Selection** section.
- 3 From the **Selection** list, choose **Outlets**.

Mass Source I

- 1 In the **Physics** toolbar, click  **Domains** and choose **Mass Source**.

To define the mass sources of evolved gas, the reaction rates are based on the volumetric current density computed by the water electrolyzer interface, and Faraday's second law of electrolysis.

- 2 In the **Settings** window for **Mass Source**, locate the **Domain Selection** section.
- 3 From the **Selection** list, choose **GDEs**.
- 4 Locate the **Mass Source** section. From the Q_{sg} list, choose **Mass source, gas phase (we)**.
- 5 In the **Model Builder** window, collapse the **Phase Transport in Free and Porous Media Flow (phtr)** node.

HEAT TRANSFER IN SOLIDS AND FLUIDS (HT)

Now set up the **Heat Transfer** interface.

Fluid 1

- 1 In the **Model Builder** window, under **Component 1 (comp1) > Heat Transfer in Solids and Fluids (ht)** click **Fluid 1**.
- 2 In the **Settings** window for **Fluid**, locate the **Domain Selection** section.
- 3 From the **Selection** list, choose **Channels**.
- 4 Locate the **Model Input** section. From the p_A list, choose **User defined**. In the associated text field, type ρ_{A_liquid} .
- 5 From the c list, choose **Common model input**.
- 6 Locate the **Heat Convection** section. From the \mathbf{u} list, choose **Velocity field (spf)**.
- 7 Locate the **Heat Conduction, Fluid** section. From the k list, choose **User defined**. In the associated text field, type $\kappa_{two_phase_mix}$.
- 8 Locate the **Thermodynamics, Fluid** section. From the **Fluid type** list, choose **Gas/Liquid**.
- 9 From the ρ list, choose **User defined**. In the associated text field, type ρ_{mix} .
- 10 From the C_p list, choose **User defined**. In the associated text field, type $C_{p_two_phase_mix}$.
- 11 From the γ list, choose **User defined**.

Initial Values 1

- 1 In the **Model Builder** window, click **Initial Values 1**.
- 2 In the **Settings** window for **Initial Values**, locate the **Initial Values** section.
- 3 In the T text field, type T_0 .

Porous Medium - Separators

- 1 In the **Physics** toolbar, click  **Domains** and choose **Porous Medium**.
- 2 In the **Settings** window for **Porous Medium**, type Porous Medium - Separators in the **Label** text field.
- 3 Locate the **Domain Selection** section. From the **Selection** list, choose **Separators**.

Fluid 1

- 1 In the **Model Builder** window, click **Fluid 1**.
- 2 In the **Settings** window for **Fluid**, locate the **Model Input** section.
- 3 From the p_A list, choose **User defined**. From the c list, choose **Common model input**.
- 4 Locate the **Thermodynamics, Fluid** section. From the γ list, choose **User defined**.

Porous Matrix 1

- 1 In the **Model Builder** window, click **Porous Matrix 1**.

- 2 In the **Settings** window for **Porous Matrix**, locate the **Matrix Properties** section.
- 3 From the ϵ_p list, choose **User defined**. In the associated text field, type `eps1_sep`.
- 4 Locate the **Heat Conduction, Porous Matrix** section. From the k_b list, choose **User defined**. In the associated text field, type `kappa_sep`.
- 5 Locate the **Thermodynamics, Porous Matrix** section. From the ρ_b list, choose **User defined**. In the associated text field, type `rho_sep`.
- 6 From the $C_{p,b}$ list, choose **User defined**. In the associated text field, type `Cp_sep`.

Porous Medium - GDEs

- 1 In the **Physics** toolbar, click  **Domains** and choose **Porous Medium**.
- 2 In the **Settings** window for **Porous Medium**, type Porous Medium - GDEs in the **Label** text field.
- 3 Locate the **Domain Selection** section. From the **Selection** list, choose **GDEs**.

Fluid 1

- 1 In the **Model Builder** window, click **Fluid 1**.
- 2 In the **Settings** window for **Fluid**, locate the **Model Input** section.
- 3 From the p_A list, choose **User defined**. In the associated text field, type `pA_liquid`.
- 4 From the c list, choose **Common model input**.
- 5 Locate the **Heat Convection** section. From the \mathbf{u} list, choose **Total Darcy velocity field (dl/porous1)**.
- 6 Locate the **Heat Conduction, Fluid** section. From the k_f list, choose **User defined**. In the associated text field, type `kappa_two_phase_mix`.
- 7 Locate the **Thermodynamics, Fluid** section. From the ρ_f list, choose **User defined**. In the associated text field, type `rho_mix`.
- 8 From the $C_{p,f}$ list, choose **User defined**. In the associated text field, type `Cp_two_phase_mix`.
- 9 From the γ list, choose **User defined**.

Porous Matrix 1

- 1 In the **Model Builder** window, click **Porous Matrix 1**.
- 2 In the **Settings** window for **Porous Matrix**, locate the **Matrix Properties** section.
- 3 From the ϵ_p list, choose **User defined**. In the associated text field, type `eps_pores`.
- 4 Locate the **Heat Conduction, Porous Matrix** section. From the k_b list, choose **User defined**. In the associated text field, type `kappa_Ni`.

- 5 Locate the **Thermodynamics, Porous Matrix** section. From the ρ_b list, choose **User defined**. In the associated text field, type rho_Ni.
- 6 From the $C_{p,b}$ list, choose **User defined**. In the associated text field, type Cp_Ni.

Periodic Condition 1

- 1 In the **Physics** toolbar, click  **Boundaries** and choose **Periodic Condition**.
- 2 Select Boundaries 23 and 54 only.

Inflow 1

- 1 In the **Physics** toolbar, click  **Boundaries** and choose **Inflow**.
- 2 In the **Settings** window for **Inflow**, locate the **Boundary Selection** section.
- 3 From the **Selection** list, choose **Inlets**.
- 4 Locate the **Upstream Properties** section. In the T_{ustr} text field, type T0.

Outflow 1

- 1 In the **Physics** toolbar, click  **Boundaries** and choose **Outflow**.
- 2 In the **Settings** window for **Outflow**, locate the **Boundary Selection** section.
- 3 From the **Selection** list, choose **Outlets**.
- 4 In the **Model Builder** window, collapse the **Heat Transfer in Solids and Fluids (ht)** node.

MULTIPHYSICS

All physics-interface settings are now complete. To finalize the physics setup, also the some settings on the multiphysics nodes are required. These nodes define couplings between the individual physics interfaces.

Mixture Model 1 (mfmm1)

- 1 In the **Model Builder** window, under **Component 1 (comp1) > Multiphysics** click **Mixture Model 1 (mfmm1)**.
- 2 In the **Settings** window for **Mixture Model**, locate the **Model Input** section.
- 3 From the T list, choose **Common model input**.
- 4 Locate the **Physical Model** section. From the **Dispersed phase** list, choose **Liquid droplets/bubbles**.
- 5 Select the **Include shear-induced migration** checkbox.
- 6 Locate the **Dispersed Phase 2 Properties** section. From the ρ_{sg} list, choose **Density of gas phase (we)**.
- 7 From the μ_{sg} list, choose **Dynamic viscosity of gas phase (we)**.

Electrochemical Heating 1 (ech1)

In the **Physics** toolbar, click  **Multiphysics Couplings** and choose **Domain > Electrochemical Heating**.

GLOBAL DEFINITIONS

As a last step to finalize the physics settings, we will define the KOH concentration in the **Default Model Inputs** node. This concentration will be used for computing the KOH density in all nodes.

Default Model Inputs

- 1 In the **Model Builder** window, under **Global Definitions** click **Default Model Inputs**.
- 2 In the **Settings** window for **Default Model Inputs**, locate the **Browse Model Inputs** section.
- 3 In the tree, select **General > Concentration (mol/m³) - minput.c**.
- 4 Find the **Expression for remaining selection** subsection. In the **Concentration** text field, type `c_KOH`.

MULTIPHYSICS

In the **Model Builder** window, collapse the **Component 1 (comp1) > Multiphysics** node.

MESH 1

A user-defined mesh will be used in this model. The extruded channel geometry is suitable for using a swept mesh. First we define the surface meshes on the faces that are to be used for sweeping.

Mapped 1

- 1 In the **Mesh** toolbar, click  **More Generators** and choose **Mapped**.
- 2 In the **Settings** window for **Mapped**, locate the **Boundary Selection** section.
- 3 From the **Selection** list, choose **Mapped Mesh Boundaries**.

Distribution 1

- 1 Right-click **Mapped 1** and choose **Distribution**.
- 2 Select Edges 36, 45, 51, 60, 88, 94, 98, 104, and 201 only.

Distribution 2

- 1 In the **Model Builder** window, right-click **Mapped 1** and choose **Distribution**.
- 2 Select Edges 33, 48, 63, 86, 96, 106, and 202 only.
- 3 In the **Settings** window for **Distribution**, locate the **Distribution** section.
- 4 In the **Number of elements** text field, type 2.

Size 1

- 1 Right-click **Mapped 1** and choose **Size**.
- 2 In the **Settings** window for **Size**, locate the **Element Size** section.
- 3 Click the **Custom** button.
- 4 Locate the **Element Size Parameters** section.
- 5 Select the **Maximum element size** checkbox. In the associated text field, type $W_{rib}/10$.
- 6 Click  **Build Selected**.

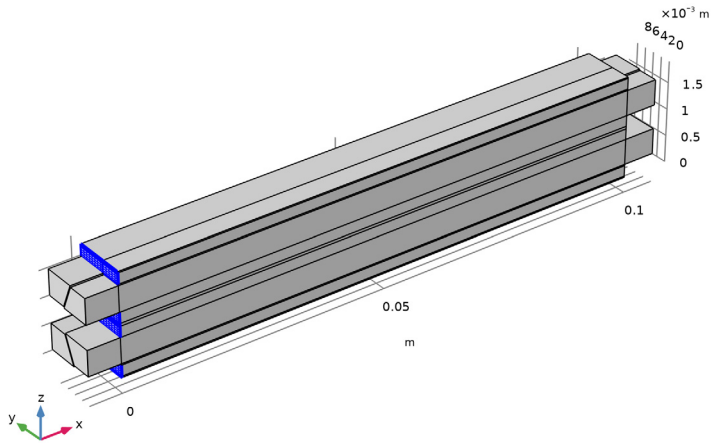

Free Triangular 1

- 1 In the **Mesh** toolbar, click  **More Generators** and choose **Free Triangular**.
- 2 In the **Settings** window for **Free Triangular**, locate the **Boundary Selection** section.
- 3 From the **Selection** list, choose **Triangular Mesh Boundaries**.

Size 1

- 1 Right-click **Free Triangular 1** and choose **Size**.
- 2 In the **Settings** window for **Size**, locate the **Element Size** section.
- 3 Click the **Custom** button.
- 4 Locate the **Element Size Parameters** section.
- 5 Select the **Maximum element size** checkbox. In the associated text field, type $H_{ch}/4$.
- 6 Click  **Build Selected**.

7 Click the  **Wireframe Rendering** button in the **Graphics** toolbar.

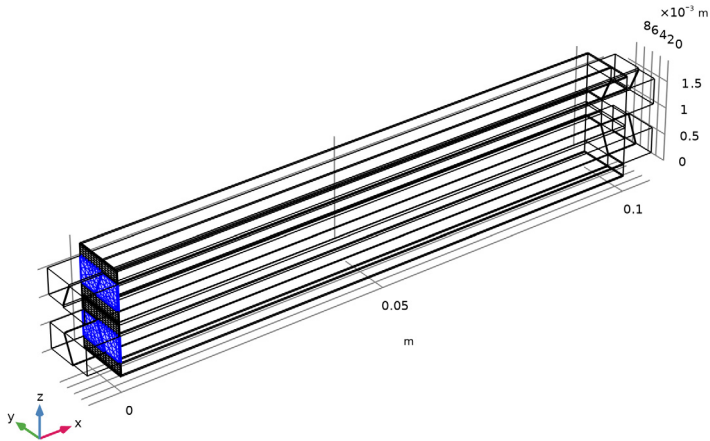

Boundary Layers 1

- 1 In the **Mesh** toolbar, click  **Boundary Layers**.
- 2 In the **Settings** window for **Boundary Layers**, locate the **Geometric Entity Selection** section.
- 3 From the **Geometric entity level** list, choose **Boundary**.
- 4 From the **Selection** list, choose **Triangular Mesh Boundaries**.

Boundary Layer Properties

- 1 In the **Model Builder** window, click **Boundary Layer Properties**.
- 2 In the **Settings** window for **Boundary Layer Properties**, locate the **Edge Selection** section.
- 3 From the **Selection** list, choose **All edges**.
- 4 Select Edges 43, 46, 55, 58, 68, 70, 72, 73, 75, 76, 82, and 84 only.
- 5 Locate the **Layers** section. In the **Number of layers** text field, type 2.
- 6 In the **Stretching factor** text field, type 1.5.
- 7 From the **Thickness specification** list, choose **First layer**.
- 8 In the **Thickness** text field, type $H_{ch}/50$.

9 Click  **Build Selected**.

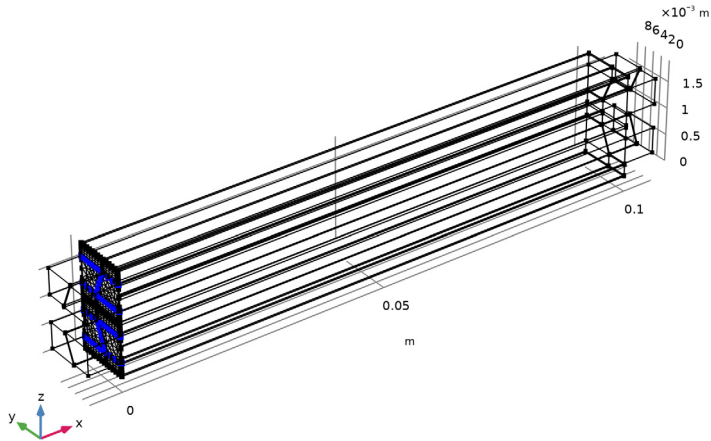



Swept 1

In the **Mesh** toolbar, click  **Swept**.

Size 1

- 1 Right-click **Swept 1** and choose **Size**.
- 2 In the **Settings** window for **Size**, locate the **Element Size** section.
- 3 Click the **Custom** button.
- 4 Locate the **Element Size Parameters** section.
- 5 Select the **Maximum element size** checkbox. In the associated text field, type $W_{ribch}/10$.

Distribution 1

- 1 In the **Model Builder** window, right-click **Swept 1** and choose **Distribution**.
- 2 In the **Settings** window for **Distribution**, locate the **Domain Selection** section.
- 3 Click  **Clear Selection**.
- 4 Select Domains 1–4 only.
- 5 Locate the **Distribution** section. From the **Distribution type** list, choose **Predefined**.
- 6 In the **Element ratio** text field, type 4.
- 7 Click  **Build All**.

8 Click the  **Wireframe Rendering** button in the **Graphics** toolbar.

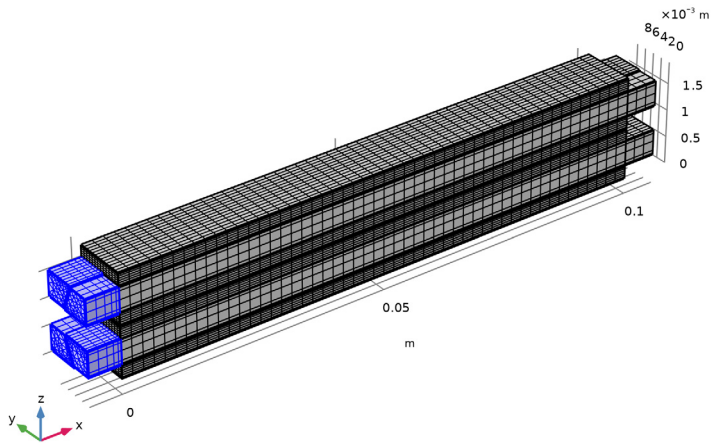

MESH 1

In the **Model Builder** window, collapse the **Component 1 (comp1) > Mesh 1** node.

STUDY 1

The problem is solved in three steps. The first step initializes the current distribution of the electrolyzer interface. The second step computes the flow profiles, excluding phase transport. The final step computes the solution for all physics, ramping up the cell voltage.

Step 3: Stationary 2

In the **Study** toolbar, click  **Stationary**.

Stationary - Flow Initialization

- 1 In the **Model Builder** window, click **Step 2: Stationary**.
- 2 In the **Settings** window for **Stationary**, type **Stationary - Flow Initialization** in the **Label** text field.
- 3 Locate the **Physics and Variables Selection** section. In the **Solve for** column of the table, under **Component 1 (comp1)**, clear the checkboxes for **Water Electrolyzer (we)**, **Phase Transport in Free and Porous Media Flow (phtr)**, and **Heat Transfer in Solids and Fluids (ht)**.

Stationary 2- All Physics

- 1 In the **Model Builder** window, click **Step 3: Stationary 2**.
- 2 In the **Settings** window for **Stationary**, type Stationary 2- All Physics in the **Label** text field.
- 3 Click to expand the **Study Extensions** section. Select the **Auxiliary sweep** checkbox.
- 4 Click **+ Add**.
- 5 In the table, enter the following settings:

| Parameter name | Parameter value list | Parameter unit |
|-----------------------|--|----------------|
| E_cell (Cell voltage) | range(E_cell_lower, 0.1, E_cell_upper) | V |

Solution 1 (sol1)

A fully coupled solver is suitable for this fairly small problem, and makes the simulation run faster.

- 1 In the **Study** toolbar, click  **Show Default Solver**.
- 2 In the **Model Builder** window, expand the **Solution 1 (sol1)** node.
- 3 Right-click **Study 1 > Solver Configurations > Solution 1 (sol1) > Stationary Solver 3** and choose **Fully Coupled**.

DEFINITIONS

As a final step before solving, also add an average operator. It will be used later on when postprocessing the solution.

Average 1 (aveop1)

- 1 In the **Definitions** toolbar, click  **Nonlocal Couplings** and choose **Average**.
- 2 In the **Settings** window for **Average**, locate the **Source Selection** section.
- 3 From the **Geometric entity level** list, choose **Boundary**.
- 4 Select Boundary 54 only.

STUDY 1

- 1 In the **Model Builder** window, click **Study 1**.
- 2 In the **Settings** window for **Study**, locate the **Study Settings** section.
- 3 Clear the **Generate default plots** checkbox.
- 4 In the **Study** toolbar, click **= Compute**.

Proceed as follows to reproduce all remaining figures from the model documentation:

RESULTS

Polarization Plot

- 1 In the **Results** toolbar, click  **ID Plot Group**.
- 2 In the **Settings** window for **ID Plot Group**, type Polarization Plot in the **Label** text field.

Global I

- 1 Right-click **Polarization Plot** and choose **Global**.
- 2 In the **Settings** window for **Global**, locate the **y-Axis Data** section.
- 3 In the table, enter the following settings:

| Expression | Unit | Description |
|------------|------|--------------|
| E_cell | V | Cell voltage |

- 4 Locate the **x-Axis Data** section. From the **Parameter** list, choose **Expression**.
- 5 In the **Expression** text field, type $\text{aveop1}(-\text{we.nI1})$.
- 6 In the **Unit** field, type A/cm^2 .

Polarization Plot

- 1 In the **Model Builder** window, click **Polarization Plot**.
- 2 In the **Settings** window for **ID Plot Group**, click to expand the **Title** section.
- 3 From the **Title type** list, choose **None**.
- 4 Locate the **Plot Settings** section.
- 5 Select the **x-axis label** checkbox. In the associated text field, type Average cell current density (A/cm^2).

6 Locate the **Legend** section. Clear the **Show legends** checkbox.

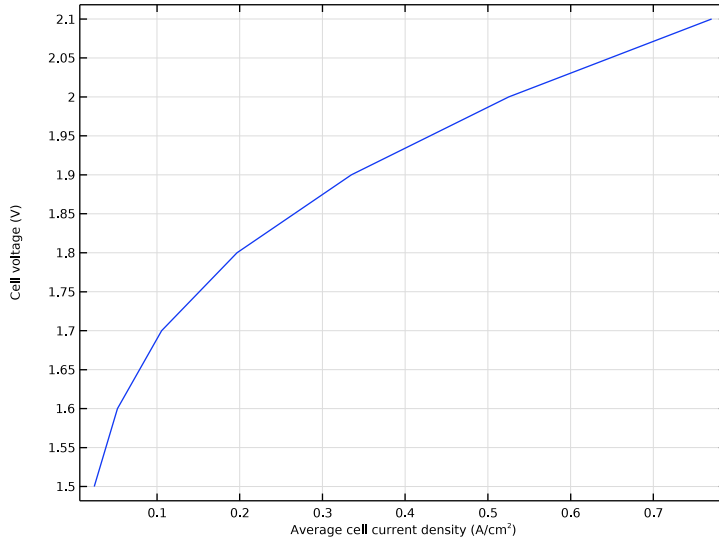

Electrode Phase Potential

- 1 In the **Results** toolbar, click  **3D Plot Group**.
- 2 In the **Settings** window for **3D Plot Group**, type **Electrode Phase Potential** in the **Label** text field.

Surface 1

- 1 Right-click **Electrode Phase Potential** and choose **Surface**.
- 2 In the **Settings** window for **Surface**, click **Replace Expression** in the upper-right corner of the **Expression** section. From the menu, choose **Component 1 (comp1) > Water Electrolyzer > we.phis - Electric potential - V**.

3 In the **Electrode Phase Potential** toolbar, click  **Plot**.

E_cell(7)=2.1 V

Electric potential (V)

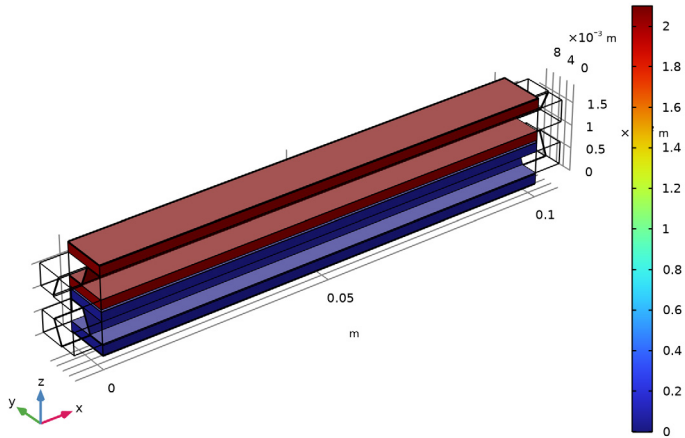

Electrolyte Phase Potential

1 In the **Results** toolbar, click  **3D Plot Group**.

2 In the **Settings** window for **3D Plot Group**, type Electrolyte Phase Potential in the **Label** text field.

Surface 1

1 Right-click **Electrolyte Phase Potential** and choose **Surface**.

2 In the **Electrolyte Phase Potential** toolbar, click  **Plot**.

3 In the **Model Builder** window, click **Surface 1**.

$E_{\text{cell}}(7)=2.1 \text{ V}$

Electrolyte potential (V)

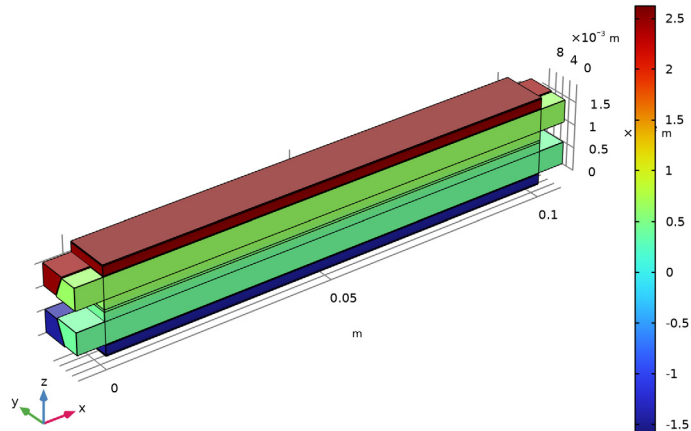

Temperature

1 In the **Results** toolbar, click  **3D Plot Group**.

2 In the **Settings** window for **3D Plot Group**, type Temperature in the **Label** text field.

Surface 1

1 Right-click **Temperature** and choose **Surface**.

2 In the **Settings** window for **Surface**, click **Replace Expression** in the upper-right corner of the **Expression** section. From the menu, choose **Component 1 (comp1) > Heat Transfer in Solids and Fluids > Temperature > T - Temperature - K**.

3 Locate the **Expression** section. From the **Unit** list, choose **°C**.

4 Locate the **Coloring and Style** section. From the **Color table** list, choose **HeatCameraLight**.

5 In the **Temperature** toolbar, click  **Plot**.

E_cell(7)=2.1 V

Temperature (°C)

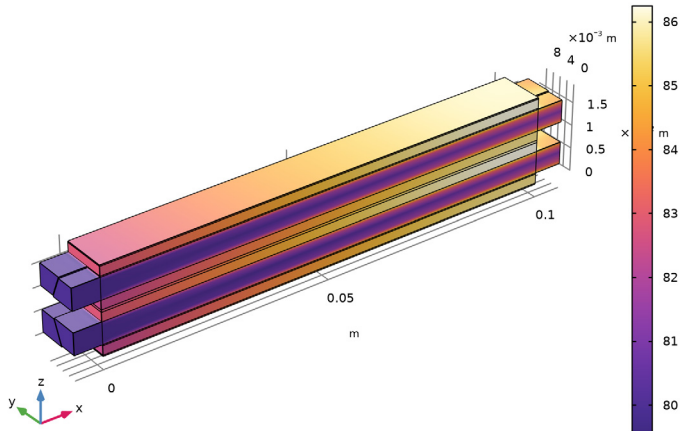

Gas Volume Fraction in Channels

- 1 In the **Results** toolbar, click  **3D Plot Group**.
- 2 In the **Settings** window for **3D Plot Group**, type **Gas Volume Fraction in Channels** in the **Label** text field.
- 3 Click to expand the **Selection** section. From the **Geometric entity level** list, choose **Domain**.
- 4 From the **Selection** list, choose **Channels**.

Volume 1

- 1 Right-click **Gas Volume Fraction in Channels** and choose **Volume**.
- 2 In the **Settings** window for **Volume**, click **Replace Expression** in the upper-right corner of the **Expression** section. From the menu, choose **Component 1 (comp1) > Phase Transport in Free and Porous Media Flow > s_g - Volume fraction - I**.
- 3 Locate the **Coloring and Style** section. From the **Color table** list, choose **Prism**.

4 In the **Gas Volume Fraction in Channels** toolbar, click  **Plot**.

E_cell(7)=2.1 V

Volume fraction (1)

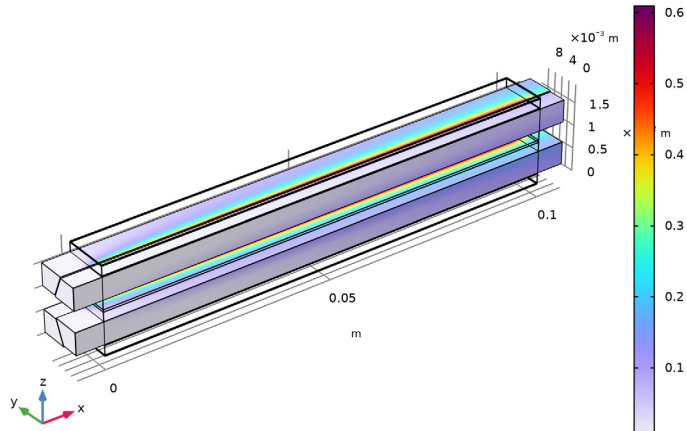

Gas Volume Fraction in GDEs

- 1 In the **Model Builder** window, right-click **Gas Volume Fraction in Channels** and choose **Duplicate**.
- 2 In the **Settings** window for **3D Plot Group**, type Gas Volume Fraction in GDEs in the **Label** text field.
- 3 Locate the **Selection** section. From the **Selection** list, choose **GDEs**.

- 4 In the **Gas Volume Fraction in GDEs** toolbar, click  **Plot**.

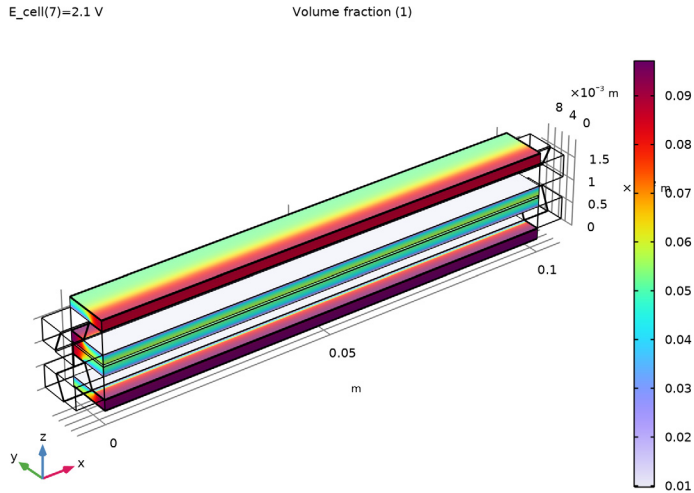

Gas Volume Fractions and Streamlines

- 1 In the **Results** toolbar, click  **3D Plot Group**.
- 2 In the **Settings** window for **3D Plot Group**, type Gas Volume Fractions and Streamlines in the **Label** text field.
- 3 Click to expand the **Title** section. From the **Title type** list, choose **None**.
- 4 Locate the **Plot Settings** section. Clear the **Plot dataset edges** checkbox.

Streamline 1

- 1 Right-click **Gas Volume Fractions and Streamlines** and choose **Streamline**.
- 2 In the **Settings** window for **Streamline**, click **Replace Expression** in the upper-right corner of the **Expression** section. From the menu, choose **Component 1 (comp1) > Phase Transport in Free and Porous Media Flow > phtr.Nx_s_g,...,phtr.Nz_s_g - Mass flux, phase s_g**.
- 3 Locate the **Streamline Positioning** section. From the **Positioning** list, choose **Magnitude controlled**.
- 4 In the **Maximum density level** text field, type 11.6.
- 5 Locate the **Coloring and Style** section. Find the **Line style** subsection. From the **Type** list, choose **Ribbon**.
- 6 Find the **Point style** subsection. From the **Type** list, choose **Arrow**.

Color Expression 1

- 1 Right-click **Streamline 1** and choose **Color Expression**.
- 2 In the **Settings** window for **Color Expression**, click **Replace Expression** in the upper-right corner of the **Expression** section. From the menu, choose **Component 1 (comp1) > Phase Transport in Free and Porous Media Flow > s_g - Volume fraction - 1**.

Selection 1

- 1 In the **Model Builder** window, right-click **Streamline 1** and choose **Selection**.
- 2 In the **Settings** window for **Selection**, locate the **Selection** section.
- 3 From the **Selection** list, choose **Oxygen Channels**.
- 4 In the **Gas Volume Fractions and Streamlines** toolbar, click  **Plot**.

Streamline 2

Right-click **Streamline 1** and choose **Duplicate**.

Color Expression 1

- 1 In the **Model Builder** window, expand the **Streamline 2** node, then click **Color Expression 1**.
- 2 In the **Settings** window for **Color Expression**, locate the **Coloring and Style** section.
- 3 From the **Color table** list, choose **Disco**.

Selection 1

- 1 In the **Model Builder** window, click **Selection 1**.
- 2 In the **Settings** window for **Selection**, locate the **Selection** section.
- 3 From the **Selection** list, choose **Hydrogen Channels**.
- 4 In the **Gas Volume Fractions and Streamlines** toolbar, click  **Plot**.

Surface 1

- 1 In the **Model Builder** window, right-click **Gas Volume Fractions and Streamlines** and choose **Surface**.
- 2 In the **Settings** window for **Surface**, locate the **Expression** section.
- 3 In the **Expression** text field, type 1.

Selection 1

- 1 Right-click **Surface 1** and choose **Selection**.
- 2 In the **Settings** window for **Selection**, locate the **Selection** section.
- 3 From the **Geometric entity level** list, choose **Domain**.
- 4 From the **Selection** list, choose **Separators**.

Material Appearance 1

- 1 In the **Model Builder** window, right-click **Surface 1** and choose **Material Appearance**.
- 2 In the **Settings** window for **Material Appearance**, locate the **Appearance** section.
- 3 From the **Appearance** list, choose **Custom**.

Surface 2

Right-click **Surface 1** and choose **Duplicate**.

Selection 1

- 1 In the **Model Builder** window, expand the **Surface 2** node, then click **Selection 1**.
- 2 In the **Settings** window for **Selection**, locate the **Selection** section.
- 3 From the **Selection** list, choose **GDEs**.

Material Appearance 1

- 1 In the **Model Builder** window, click **Material Appearance 1**.
- 2 In the **Settings** window for **Material Appearance**, locate the **Appearance** section.
- 3 From the **Material type** list, choose **Carbon (forged)**.

Surface 3

In the **Model Builder** window, under **Results > Gas Volume Fractions and Streamlines** right-click **Surface 2** and choose **Duplicate**.

Selection 1

- 1 In the **Model Builder** window, expand the **Surface 3** node, then click **Selection 1**.
- 2 In the **Settings** window for **Selection**, locate the **Selection** section.
- 3 From the **Selection** list, choose **Bipolar Plates**.

Material Appearance 1

- 1 In the **Model Builder** window, click **Material Appearance 1**.
- 2 In the **Settings** window for **Material Appearance**, locate the **Appearance** section.
- 3 From the **Material type** list, choose **Steel**.

4 In the **Gas Volume Fractions and Streamlines** toolbar, click  **Plot**.

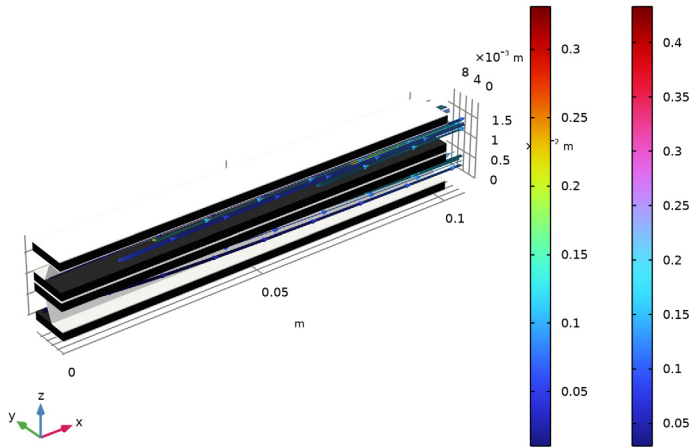

Separator Current Density

- 1 In the **Results** toolbar, click  **3D Plot Group**.
- 2 In the **Settings** window for **3D Plot Group**, type Separator Current Density in the **Label** text field.
- 3 Click to expand the **Title** section. From the **Title type** list, choose **Manual**.
- 4 In the **Title** text area, type Volume: Separator current density (A/m^2).
- 5 Locate the **Selection** section. From the **Geometric entity level** list, choose **Domain**.
- 6 From the **Selection** list, choose **Separators**.

Volume 1

- 1 Right-click **Separator Current Density** and choose **Volume**.
- 2 In the **Settings** window for **Volume**, locate the **Expression** section.
- 3 In the **Expression** text field, type $abs(w_e \cdot I1z)$.
- 4 Locate the **Coloring and Style** section. From the **Color table** list, choose **Prism**.

5 In the **Separator Current Density** toolbar, click  **Plot**.

E_cell(7)=2.1 V

Volume: Separator current density (A/m²)

