



Model created in COMSOL Multiphysics 6.4

# Fuel Cell Stack Cooling

## *Introduction*

---

This tutorial models the thermal management of a polymer electrolyte membrane (PEM) fuel cell stack. Operating the stack with similar temperature profile for all cells is important since an uneven temperature distribution may otherwise result in nonuniform water vapor condensation, and a large cell-to-cell variation in performance.

The stack consists of five cells, interlayered with bipolar plates that carry the liquid cooling fluid. The model solves for the temperature, the electrode and electrolyte phase potentials, the mass transport of the reacting species in each separate gas compartment, and the fluid pressures and corresponding velocities in the gas and liquid flow compartments.

The flow channels of the bipolar plates are not resolved explicitly in the geometry. Instead anisotropic permeabilities are used to define the fluid flow patterns inside the stack.

## *Model Definition*

---

[Figure 1](#) depicts the repetitive unit cell which is used to construct the model geometry. The bipolar plate (BPP), constructed by patterned steel sheets, separates the hydrogen and oxygen (air) gas compartments, and also contains a separate flow compartment for the cooling liquid. The BPP also contains inlet and outlet manifolds to conduct the fluids to larger additional flow channels located outside the model geometry. The stack in this tutorial uses a “Z” pattern for the gas flow channels, with the direction of the air channels depicted in [Figure 1](#). For the hydrogen side, the same pattern is used, mirrored in the  $yz$ -plane. For the cooling flow, a uniform flow direction along the  $y$ -axis is assumed. Between each BPP, membrane-electrode assemblies (MEAs) are placed, consisting of one gas diffusion layer (GDL) and one gas diffusion electrode (GDE) per gas compartment, and a polymer electrolyte membrane in between.

It should be noted that the cooling flow compartments are formed by the union of the hydrogen and the oxygen sides of the BPPs, when stacking the unit cells on top of each other. Generally in stack design, as a result of only having to provide flow of one gas, the first and end plates have to be designed differently compared to the inner plates. In this tutorial the first and end plates are constructed by adding additional “half” BPPs, using the same design as in [Figure 1](#) but with the inactive gas compartment and manifold removed. As a result of this, the cooling flow to the first and last cells in the stack will become larger than for the inner cells.

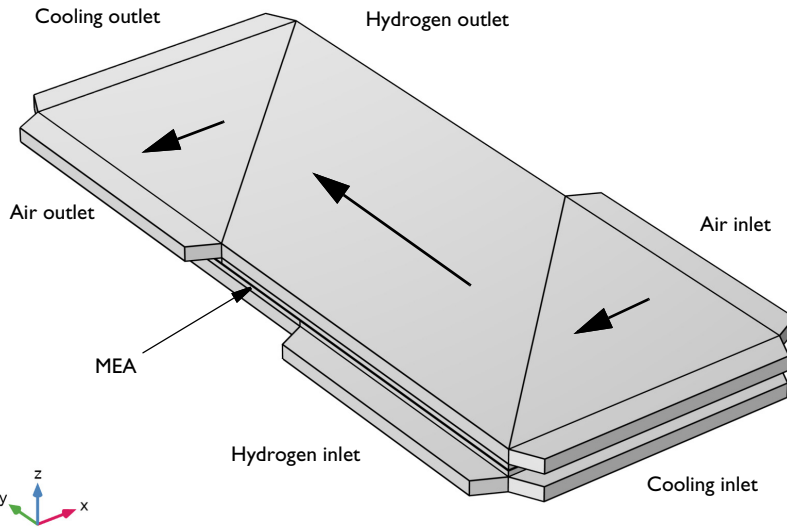
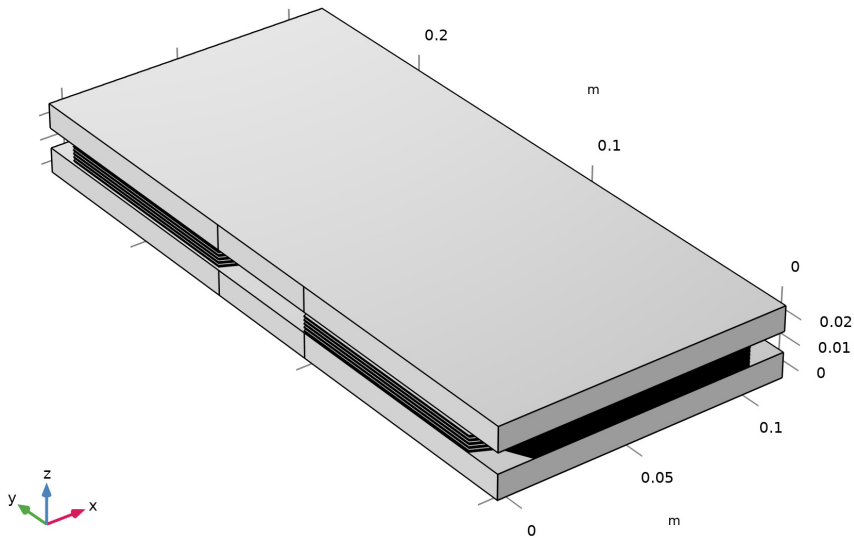

*Figure 1: Repetitive unit cell. The larger arrows indicate the orientation of the flow channels in the oxygen (air) compartment of the bipolar plate. The figure is scaled ten times in the  $z$  direction.*

The individual channels in the patterned BPPs are not resolved in the model geometry. Instead the BPPs are divided into separate domains corresponding to the main gas flow direction. Homogenized flow equations based on Darcy’s Law are then used to define the flow, using anisotropic permeabilities corresponding to the direction of the channels.

The final geometry, as shown in [Figure 2](#), is constructed by stacking five unit cells on top of each other, with the added front and end cooling “half” BPPs, as discussed above. Additional metal end blocks, used for conducting the current and for providing structural rigidity, are placed outside the stack.

The geometry is finalized as an assembly, with the assembly boundary located in the middle of the membranes. This allows since for nonmatching meshes on each side of the mid-membrane boundaries, and hence for sweeping the mesh in the through-plane direction.



*Figure 2: Model geometry consisting of five unit cells and two end blocks.*

The model is defined using one **Hydrogen Fuel Cell**, one **Heat Transfer** and one **Darcy's Law** interface.

The **Hydrogen Fuel Cell** defines the electrochemical reactions, the electrode and electrolyte charge transport, gas phase diffusion and convective flow, as well as membrane water transport. For an introduction to the hydrogen fuel cell interface, see for instance the [Mass Transport and Electrochemical Reaction in a Fuel Cell Cathode](#) and the [Low-Temperature PEM Fuel Cell with Serpentine Flow Field](#) examples.

The **Heat Transfer** interface solves for the temperature in the stack, applying the heat sources computed by the Hydrogen Fuel Cell interface through the **Electrochemical Heating** multiphysics node. See also the [Nonisothermal PEM Fuel Cell](#) example. Heat is only assumed to exit the stack through the cooling manifold outlets.

The additional **Darcy's Law** interface is used to compute the flow profile of the cooling liquid, which is used in the Heat Transfer interface.

The model is solved for a range of average cell voltages using a stationary solver.

## Results and Discussion

Figure 3 shows the electrode phase potential in the stack for an average cell voltage of 0.55 V.

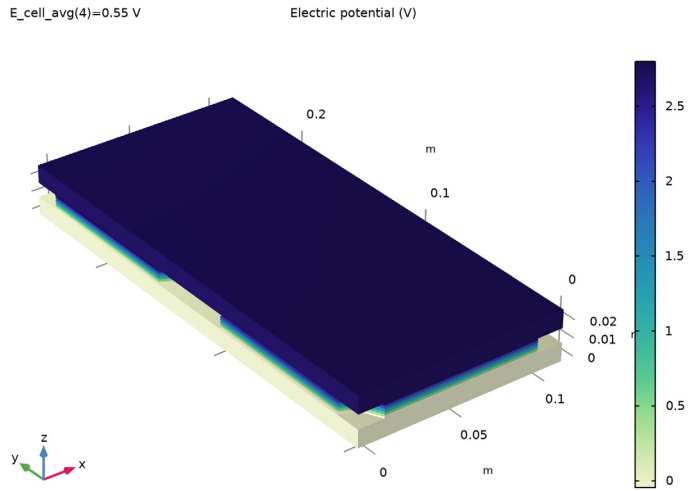

Figure 3: Electrode phase potential.

Figure 4 shows the hydrogen molar fraction. As a result of the consumption of hydrogen, the molar fraction decreases toward the outlet.

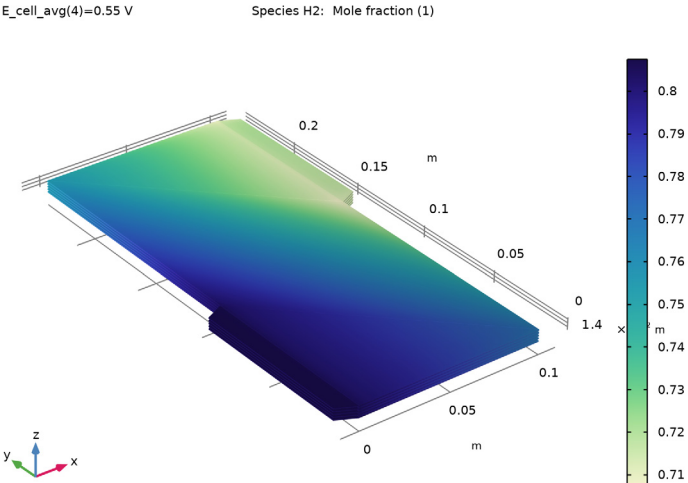
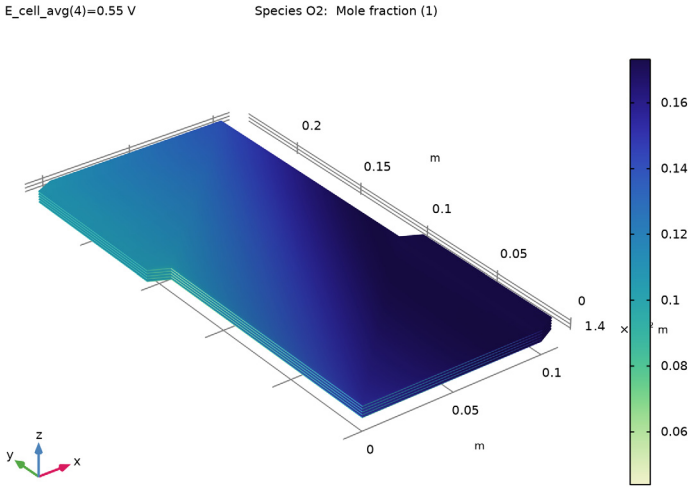

Figure 4: Hydrogen molar fraction.

Similarly, [Figure 5](#) shows the oxygen molar fraction in the air gas compartment. Depletion effects are somewhat more severe than for the hydrogen side.



*Figure 5: Oxygen molar fraction.*

Figure 6 shows the cooling flow streamlines and the corresponding temperature. The temperature increases toward the outlet.

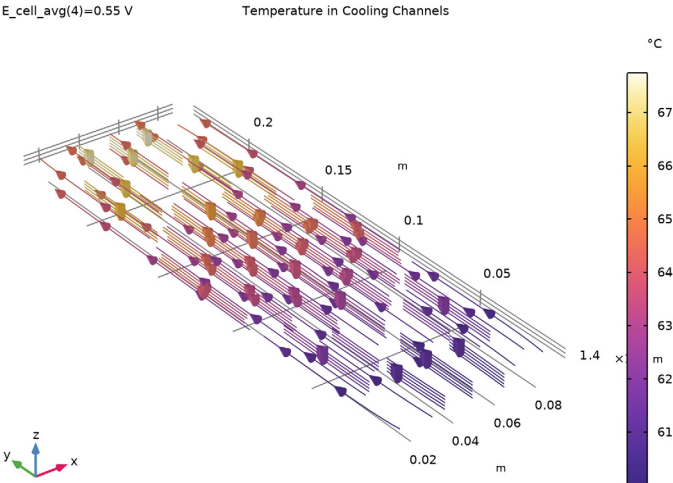

Figure 6: Temperature (color legend) and cooling flow stream lines.

Figure 7 shows the temperature in the MEAs. The temperature is higher toward the membrane.

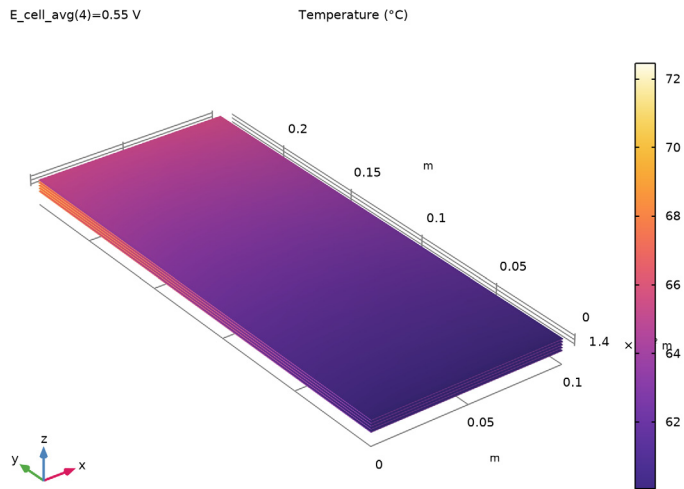
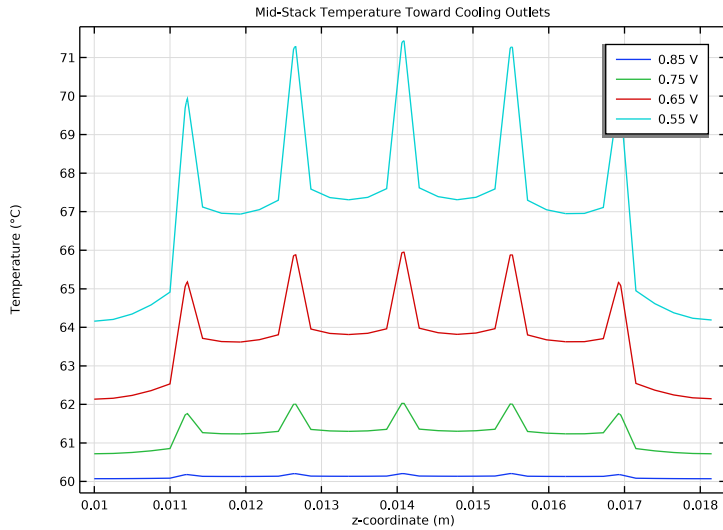

Figure 7: Temperature in the MEAs.

Figure 8 elucidates the temperature profile in the through-plane direction of the stack further. Here the temperature is plotted along a line in the z direction, placed in the

middle of the stack in the  $x$  direction, and approximately 1 cm from the outlet cooling manifold in the  $y$  direction.



*Figure 8: Temperature along a z-directed line through the stack, close to the outlet at half of the width of the cells, for different average cell voltages.*

As can be seen, polarizing the stack results in significant temperature gradients in the MEA. We also see lower temperatures in the first and the last cells, as an effect of these cells receiving, on average, more cooling flow compared to the inner cells.

Finally, [Figure 9](#) shows the water activity (relative humidity) in the oxygen gas diffusion layer.

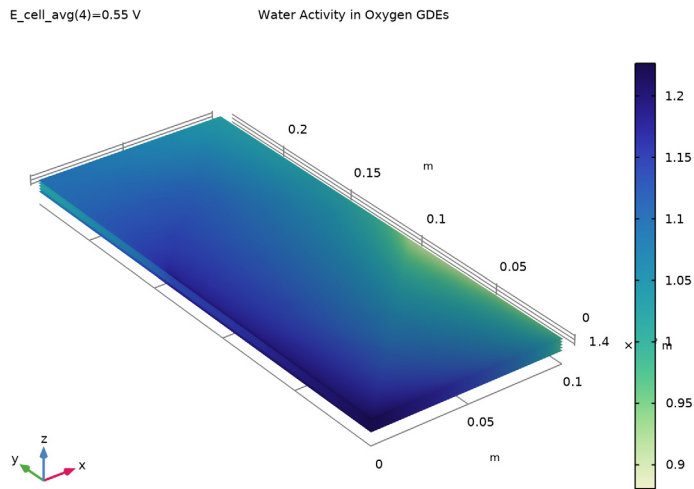

*Figure 9: Water activity in the oxygen gas diffusion electrodes.*

The relative humidity is related both to water production and the temperature. As a result of the water production in the cell, one would generally expect the relative humidity to be higher toward the outlet. However, at the same time the higher temperature toward the outlet counteracts this, resulting in a more complex behavior, depending both on the straight cooling fluid and the gas “Z”-flow field design.

Also note that the humidity levels are generally higher in the first and last cell of the stack. This is due to the generally lower temperatures in these two cells. This indicates that these two cells will be more susceptible to water flooding. To improve the stack design one could consider modifying the cooling flow patterns to reduce the cooling of the first and the end cells.

---

**Application Library path:** Fuel\_Cell\_and\_Electrolyzer\_Module/Fuel\_Cells/  
stack\_cooling



---

From the **File** menu, choose **New**.

## **NEW**

In the **New** window, click  **Model Wizard**.

## **MODEL WIZARD**

- 1 In the **Model Wizard** window, click  **3D**.
- 2 In the **Select Physics** tree, select **Electrochemistry > Hydrogen Fuel Cells > Proton Exchange Membrane (fc)**.
- 3 Click **Add**.
- 4 In the **Select Physics** tree, select **Fluid Flow > Porous Media and Subsurface Flow > Darcy's Law (dl)**.
- 5 Click **Add**.
- 6 In the **Select Physics** tree, select **Heat Transfer > Porous Media > Heat Transfer in Porous Media (ht)**.
- 7 Click **Add**.
- 8 Click  **Study**.
- 9 In the **Select Study** tree, select **Preset Studies for Selected Physics Interfaces > Hydrogen Fuel Cell > Stationary with Initialization**.
- 10 Click  **Done**.

## **GEOMETRY I**

Insert the geometry sequence from a file.

- 1 In the **Geometry** toolbar, click **Insert Sequence** and choose **Insert Sequence**.
- 2 Browse to the model's Application Libraries folder and double-click the file `stack_cooling_geom_sequence.mph`.
- 3 In the **Geometry** toolbar, click  **Build All**.

4 In the **Model Builder** window, under **Component 1 (comp1)** click **Geometry 1**.

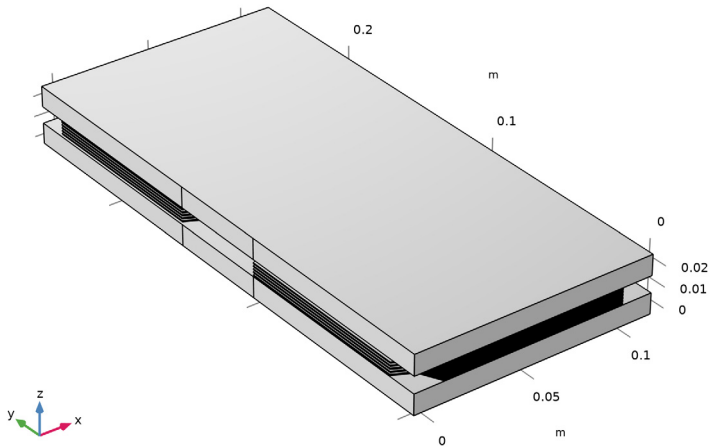

Disable the analysis of the geometry as the remaining small geometric details are needed.

- 5 In the **Model Builder** window, click **Geometry 1**.
- 6 In the **Settings** window for **Geometry**, locate the **Cleanup** section.
- 7 Clear the **Automatic detection of small details** checkbox.
- 8 In the **Geometry** toolbar, click  **Build All**.
- 9 In the **Model Builder** window, collapse the **Geometry 1** node.

## GLOBAL DEFINITIONS

### *Geometry Parameters*

Some parameters were imported when you imported the geometry sequence. Load some additional parameters required for setting up the physics from a text file.



- 1 In the **Model Builder** window, under **Global Definitions** click **Parameters 1**.
- 2 In the **Settings** window for **Parameters**, type **Geometry Parameters** in the **Label** text field.

### *Physics Parameters*

- 1 In the **Home** toolbar, click  **Parameters** and choose **Add > Parameters**.

- 2 In the **Settings** window for **Parameters**, type Physics Parameters in the **Label** text field.
- 3 Locate the **Parameters** section. Click  **Load from File**.
- 4 Browse to the model's Application Libraries folder and double-click the file `stack_cooling_physics_parameters.txt`.

## ADD MATERIAL

- 1 In the **Materials** toolbar, click  **Add Material** to open the **Add Material** window. Now add some materials from the Material Libraries.
- 2 Go to the **Add Material** window.
- 3 In the tree, select **Built-in > Steel AISI 4340**.
- 4 Right-click and choose **Add to Component 1 (comp1)**.
- 5 In the tree, select **Built-in > Water, liquid**.
- 6 Right-click and choose **Add to Component 1 (comp1)**.
- 7 In the tree, select **Fuel Cell and Electrolyzer > Polymer Electrolytes > Nafion®, EW 1100, Vapor Equilibrated, Protonated**.
- 8 Right-click and choose **Add to Component 1 (comp1)**.
- 9 In the **Materials** toolbar, click  **Add Material** to close the **Add Material** window.

## MATERIALS

### *Steel AISI 4340 (mat1)*

Assign the materials you added to different parts of the geometry.

- 1 In the **Settings** window for **Material**, locate the **Geometric Entity Selection** section.
- 2 From the **Selection** list, choose **Current Collector and Feeder Plates**.

### *Water, liquid (mat2)*

- 1 In the **Model Builder** window, click **Water, liquid (mat2)**.
- 2 In the **Settings** window for **Material**, locate the **Geometric Entity Selection** section.
- 3 From the **Selection** list, choose **Cooling Channels and Manifolds**.

### *Nafion®, EW 1100, Vapor Equilibrated, Protonated (mat3)*

- 1 In the **Model Builder** window, click **Nafion®, EW 1100, Vapor Equilibrated, Protonated (mat3)**.
- 2 In the **Settings** window for **Material**, locate the **Geometric Entity Selection** section.
- 3 From the **Selection** list, choose **Membranes**.

## HYDROGEN FUEL CELL (FC)

Now start defining the physics. Begin when the fuel cell interface.

- 1 In the **Model Builder** window, under **Component 1 (comp1)** click **Hydrogen Fuel Cell (fc)**.
- 2 In the **Settings** window for **Hydrogen Fuel Cell**, locate the **H2 Gas Mixture** section.
- 3 Find the **Transport mechanisms** subsection. Select the **Use Darcy's Law for momentum transport** checkbox.
- 4 Locate the **O2 Gas Mixture** section. Select the **Use Darcy's Law for momentum transport** checkbox.
- 5 Click to expand the **Electrolyte and Membrane Transport** section. Select the **Electroosmotic water drag** checkbox.

### *Membrane 1*

- 1 In the **Physics** toolbar, click  **Domains** and choose **Membrane**.
- 2 In the **Settings** window for **Membrane**, locate the **Domain Selection** section.
- 3 From the **Selection** list, choose **Membranes**.

### *Initial Values 1*

- 1 In the **Model Builder** window, expand the **Membrane 1** node, then click **Initial Values 1**.
- 2 In the **Settings** window for **Initial Values**, locate the **Initial Values** section.
- 3 In the  $T_0$  text field, type  $T_{in}$ .

### *Water Absorption-Desorption, H2 Side 1*

- 1 In the **Model Builder** window, click **Water Absorption-Desorption, H2 Side 1**.
- 2 In the **Settings** window for **Water Absorption-Desorption, H2 Side**, locate the **Absorption-Desorption Condition** section.
- 3 From the **Electrolyte material** list, choose **Nafion®, EW 1100, Vapor Equilibrated, Protonated (mat3)**.

### *Water Absorption-Desorption, O2 Side 1*

- 1 In the **Model Builder** window, click **Water Absorption-Desorption, O2 Side 1**.
- 2 In the **Settings** window for **Water Absorption-Desorption, O2 Side**, locate the **Absorption-Desorption Condition** section.
- 3 From the **Electrolyte material** list, choose **Nafion®, EW 1100, Vapor Equilibrated, Protonated (mat3)**.

### *H2 Gas Diffusion Layer 1*

- 1 In the **Physics** toolbar, click  **Domains** and choose **H2 Gas Diffusion Layer**.

- 2 In the **Settings** window for **H2 Gas Diffusion Layer**, locate the **Domain Selection** section.
- 3 From the **Selection** list, choose **Hydrogen GDLs**.
- 4 Locate the **Electrode Charge Transport** section. In the  $\sigma_s$  text field, type `sigmas_GDL`.
- 5 Locate the **Gas Transport** section. In the  $\epsilon_g$  text field, type `eps_g_GDL`.
- 6 In the  $\kappa_g$  text field, type `kappag_GDL`.

#### *O2 Gas Diffusion Layer 1*

- 1 In the **Physics** toolbar, click  **Domains** and choose **O2 Gas Diffusion Layer**.
- 2 In the **Settings** window for **O2 Gas Diffusion Layer**, locate the **Domain Selection** section.
- 3 From the **Selection** list, choose **Oxygen GDLs**.
- 4 Locate the **Electrode Charge Transport** section. In the  $\sigma_s$  text field, type `sigmas_GDL`.
- 5 Locate the **Gas Transport** section. In the  $\epsilon_g$  text field, type `epsg_GDL`.
- 6 In the  $\kappa_g$  text field, type `kappag_GDL`.

#### *H2 Gas Diffusion Layer 2 (manifolds)*

The gas channels and manifolds are modeled as homogenized domains, that is, the individual channels are not resolved in the geometry. Instead the permeability is used to control the flow velocity and the pressure drop.

- 1 In the **Physics** toolbar, click  **Domains** and choose **H2 Gas Diffusion Layer**.
- 2 In the **Settings** window for **H2 Gas Diffusion Layer**, type **H2 Gas Diffusion Layer 2 (manifolds)** in the **Label** text field.
- 3 Locate the **Domain Selection** section. From the **Selection** list, choose **Hydrogen Gas Manifolds**.
- 4 Locate the **Electrode Charge Transport** section. In the  $\sigma_s$  text field, type `sigma_BPP_eff`.
- 5 Locate the **Gas Transport** section. In the  $\epsilon_g$  text field, type `eps_gas_BPP`.
- 6 In the  $\kappa_g$  text field, type `perm_gas_BPP`.

#### *O2 Gas Diffusion Layer 2 (manifolds)*

- 1 In the **Physics** toolbar, click  **Domains** and choose **O2 Gas Diffusion Layer**.
- 2 In the **Settings** window for **O2 Gas Diffusion Layer**, type **O2 Gas Diffusion Layer 2 (manifolds)** in the **Label** text field.
- 3 Locate the **Domain Selection** section. From the **Selection** list, choose **Oxygen Gas Manifolds**.
- 4 Locate the **Electrode Charge Transport** section. In the  $\sigma_s$  text field, type `sigma_BPP_eff`.
- 5 Locate the **Gas Transport** section. In the  $\epsilon_g$  text field, type `eps_gas_BPP`.

6 In the  $\kappa_g$  text field, type perm\_gas\_BPP.

*Current Collector 1 (end blocks)*

- 1 In the **Physics** toolbar, click  **Domains** and choose **Current Collector**.
- 2 In the **Settings** window for **Current Collector**, type Current Collector 1 (end blocks) in the **Label** text field.
- 3 Locate the **Domain Selection** section. From the **Selection** list, choose **Current Collector and Feeder Plates**.
- 4 Locate the **Electrode Charge Transport** section. From the  $\sigma_s$  list, choose **From material**.

*Current Collector (with cooling flow)*

- 1 In the **Physics** toolbar, click  **Domains** and choose **Current Collector**.
- 2 In the **Settings** window for **Current Collector**, type Current Collector (with cooling flow) in the **Label** text field.
- 3 Locate the **Domain Selection** section. From the **Selection** list, choose **Non-Gas Cooling Channels and Manifolds**.
- 4 Locate the **Electrode Charge Transport** section. In the  $\sigma_s$  text field, type sigma\_BPP\_eff.

*Thin H2 Gas Diffusion Electrode 1*

- 1 In the **Physics** toolbar, click  **Boundaries** and choose **Thin H2 Gas Diffusion Electrode**.
- 2 In the **Settings** window for **Thin H2 Gas Diffusion Electrode**, locate the **Boundary Selection** section.
- 3 From the **Selection** list, choose **Hydrogen Gas Diffusion Electrodes**.
- 4 Locate the **Electrode Thickness** section. In the  $d_{gde}$  text field, type L\_CL.

*Thin H2 Gas Diffusion Electrode Reaction 1*

- 1 In the **Model Builder** window, click **Thin H2 Gas Diffusion Electrode Reaction 1**.
- 2 In the **Settings** window for **Thin H2 Gas Diffusion Electrode Reaction**, locate the **Electrode Kinetics** section.
- 3 In the  $i_{0,ref}(T)$  text field, type i0\_H2\_ref.
- 4 Locate the **Active Specific Surface Area** section. In the  $a_v$  text field, type a\_CL.

*Thin O2 Gas Diffusion Electrode 1*

- 1 In the **Physics** toolbar, click  **Boundaries** and choose **Thin O2 Gas Diffusion Electrode**.
- 2 In the **Settings** window for **Thin O2 Gas Diffusion Electrode**, locate the **Boundary Selection** section.
- 3 From the **Selection** list, choose **Oxygen Gas Diffusion Electrodes**.

4 Locate the **Electrode Thickness** section. In the  $d_{\text{gde}}$  text field, type L\_CL.

#### *Thin O2 Gas Diffusion Electrode Reaction 1*

- 1 In the **Model Builder** window, click **Thin O2 Gas Diffusion Electrode Reaction 1**.
- 2 In the **Settings** window for **Thin O2 Gas Diffusion Electrode Reaction**, locate the **Electrode Kinetics** section.
- 3 In the  $i_{0,\text{ref}}(T)$  text field, type i0\_O2\_ref.
- 4 In the  $\alpha_a$  text field, type alphaa\_O2.
- 5 Locate the **Active Specific Surface Area** section. In the  $a_v$  text field, type a\_CL.

#### *H2 Gas Diffusion Layer 3 (x-directed channels)*

As for the manifolds, the gas flow channels in the bipolar plates are also modeled as homogenized porous domains. By using anisotropic permeabilities, the flow direction can be controlled.

- 1 In the **Physics** toolbar, click  **Domains** and choose **H2 Gas Diffusion Layer**.
- 2 In the **Settings** window for **H2 Gas Diffusion Layer**, type H2 Gas Diffusion Layer 3 (x-directed channels) in the **Label** text field.
- 3 Locate the **Domain Selection** section. From the **Selection** list, choose **Hydrogen Gas Channels, x-directed**.
- 4 Locate the **Electrode Charge Transport** section. In the  $\sigma_s$  text field, type sigma\_BPP\_eff.
- 5 Locate the **Gas Transport** section. In the  $\epsilon_g$  text field, type eps\_gas\_BPP.
- 6 From the list, choose **Diagonal**.
- 7 Specify the  $\kappa_g$  matrix as

|              |   |              |
|--------------|---|--------------|
| perm_gas_BPP | 0 | 0            |
| 0            | 0 | 0            |
| 0            | 0 | perm_gas_BPP |

#### *H2 Gas Diffusion Layer 4 (y-directed channels)*

- 1 In the **Physics** toolbar, click  **Domains** and choose **H2 Gas Diffusion Layer**.
- 2 In the **Settings** window for **H2 Gas Diffusion Layer**, type H2 Gas Diffusion Layer 4 (y-directed channels) in the **Label** text field.
- 3 Locate the **Domain Selection** section. From the **Selection** list, choose **Hydrogen Gas Channels, y-directed**.
- 4 Locate the **Electrode Charge Transport** section. In the  $\sigma_s$  text field, type sigma\_BPP\_eff.
- 5 Locate the **Gas Transport** section. In the  $\epsilon_g$  text field, type eps\_gas\_BPP.

6 From the list, choose **Diagonal**.

7 Specify the  $\kappa_g$  matrix as

|   |              |              |
|---|--------------|--------------|
| 0 | 0            | 0            |
| 0 | perm_gas_BPP | 0            |
| 0 | 0            | perm_gas_BPP |

*O2 Gas Diffusion Layer 3 (x-directed channels)*

1 In the **Physics** toolbar, click  **Domains** and choose **O2 Gas Diffusion Layer**.

2 In the **Settings** window for **O2 Gas Diffusion Layer**, type O2 Gas Diffusion Layer 3 (x-directed channels) in the **Label** text field.

3 Locate the **Domain Selection** section. From the **Selection** list, choose **Oxygen Gas Channels, x-directed**.

4 Locate the **Electrode Charge Transport** section. In the  $\sigma_s$  text field, type sigma\_BPP\_eff.

5 Locate the **Gas Transport** section. In the  $\epsilon_g$  text field, type eps\_gas\_BPP.

6 From the list, choose **Diagonal**.

7 Specify the  $\kappa_g$  matrix as

|              |   |              |
|--------------|---|--------------|
| perm_gas_BPP | 0 | 0            |
| 0            | 0 | 0            |
| 0            | 0 | perm_gas_BPP |

*O2 Gas Diffusion Layer 4 (y-directed channels)*

1 In the **Physics** toolbar, click  **Domains** and choose **O2 Gas Diffusion Layer**.

2 In the **Settings** window for **O2 Gas Diffusion Layer**, type O2 Gas Diffusion Layer 4 (y-directed channels) in the **Label** text field.

3 Locate the **Domain Selection** section. From the **Selection** list, choose **Oxygen Gas Channels, y-directed**.

4 Locate the **Electrode Charge Transport** section. In the  $\sigma_s$  text field, type sigma\_BPP\_eff.

5 Locate the **Gas Transport** section. In the  $\epsilon_g$  text field, type eps\_gas\_BPP.

6 From the list, choose **Diagonal**.

7 Specify the  $\kappa_g$  matrix as

|   |              |              |
|---|--------------|--------------|
| 0 | 0            | 0            |
| 0 | perm_gas_BPP | 0            |
| 0 | 0            | perm_gas_BPP |

### *Electronic Conducting Phase I*

In the **Model Builder** window, click **Electronic Conducting Phase I**.

### *Electric Ground I*

- 1 In the **Physics** toolbar, click  **Attributes** and choose **Electric Ground**.
- 2 In the **Settings** window for **Electric Ground**, locate the **Boundary Selection** section.
- 3 From the **Selection** list, choose **Current Feeder Tab**.

### *Electronic Conducting Phase I*

In the **Model Builder** window, click **Electronic Conducting Phase I**.

### *Electric Potential I*

- 1 In the **Physics** toolbar, click  **Attributes** and choose **Electric Potential**.
- 2 In the **Settings** window for **Electric Potential**, locate the **Boundary Selection** section.
- 3 From the **Selection** list, choose **Current Collector Tab**.
- 4 Locate the **Electric Potential** section. In the  $\phi_{s,bnd}$  text field, type  $E_{stack}$ .

### *Initial Values I*

- 1 In the **Model Builder** window, under **Component 1 (comp1) > Hydrogen Fuel Cell (fc) > H2 Gas Phase 1** click **Initial Values I**.
- 2 In the **Settings** window for **Initial Values**, locate the **Initial Composition** section.
- 3 From the **Mixture specification** list, choose **Humidified mixture**.
- 4 In the  $T_{hum}$  text field, type  $T_{in}$ .
- 5 In the  $p_{A,hum}$  text field, type  $1[atm]+p_{in\_an}$ .
- 6 Locate the **Initial Pressure** section. In the  $p_0$  text field, type  $p_{in\_an}$ .

### *H2 Gas Phase I*

In the **Model Builder** window, click **H2 Gas Phase I**.

### *H2 Inlet I*

- 1 In the **Physics** toolbar, click  **Attributes** and choose **H2 Inlet**.
- 2 In the **Settings** window for **H2 Inlet**, locate the **Boundary Selection** section.
- 3 From the **Selection** list, choose **Hydrogen Inlets**.
- 4 Locate the **Inlet Flow Type** section. From the **Inlet flow type** list, choose **Mixture composition constraint**.

### *H2 Gas Phase I*

In the **Model Builder** window, click **H2 Gas Phase I**.

### *H2 Outlet 1*

- 1 In the **Physics** toolbar, click  **Attributes** and choose **H2 Outlet**.
- 2 In the **Settings** window for **H2 Outlet**, locate the **Boundary Selection** section.
- 3 From the **Selection** list, choose **Hydrogen Outlets**.

### *Initial Values 1*

- 1 In the **Model Builder** window, under **Component 1 (comp1) > Hydrogen Fuel Cell (fc) > O2 Gas Phase 1** click **Initial Values 1**.
- 2 In the **Settings** window for **Initial Values**, locate the **Initial Composition** section.
- 3 From the **Mixture specification** list, choose **Humidified air**.
- 4 In the  $T_{\text{hum}}$  text field, type  $T_{\text{in}}$ .
- 5 In the  $p_{A,\text{hum}}$  text field, type  $1[\text{atm}] + p_{\text{in\_cath}}$ .
- 6 Locate the **Initial Pressure** section. In the  $p_0$  text field, type  $p_{\text{in\_cath}}$ .

### *O2 Gas Phase 1*

In the **Model Builder** window, click **O2 Gas Phase 1**.



### *O2 Inlet 1*

- 1 In the **Physics** toolbar, click  **Attributes** and choose **O2 Inlet**.
- 2 In the **Settings** window for **O2 Inlet**, locate the **Boundary Selection** section.
- 3 From the **Selection** list, choose **Oxygen Inlets**.
- 4 Locate the **Inlet Flow Type** section. From the **Inlet flow type** list, choose **Mixture composition constraint**.

### *O2 Gas Phase 1*

In the **Model Builder** window, click **O2 Gas Phase 1**.

### *O2 Outlet 1*

- 1 In the **Physics** toolbar, click  **Attributes** and choose **O2 Outlet**.
- 2 In the **Settings** window for **O2 Outlet**, locate the **Boundary Selection** section.
- 3 From the **Selection** list, choose **Oxygen Outlets**.  
To improve convergence, enable stabilization to all gas flow domains. By default, stabilization is turned off in GDLs and GDEs.
- 4 Click the  **Show More Options** button in the **Model Builder** toolbar.
- 5 In the **Show More Options** dialog, in the tree, select the checkbox for the node **Physics > Stabilization**.
- 6 Click **OK**.

- 7 In the **Model Builder** window, click **Hydrogen Fuel Cell (fc)**.
- 8 In the **Settings** window for **Hydrogen Fuel Cell**, click to expand the **Consistent Stabilization** section.
- 9 Find the **O2 gas mixture** subsection. Clear the **Add stabilization only to gas flow channels** checkbox.
- 10 Find the **H2 gas mixture** subsection. Clear the **Add stabilization only to gas flow channels** checkbox.

#### **HYDROGEN FUEL CELL (FC)**

In the **Model Builder** window, collapse the **Component 1 (comp1) > Hydrogen Fuel Cell (fc)** node.

#### **DARCY'S LAW (DL)**

Now set up the Darcy's law interface, which defines the cooling flow velocity and pressure.

- 1 In the **Model Builder** window, under **Component 1 (comp1)** click **Darcy's Law (dl)**.
- 2 In the **Settings** window for **Darcy's Law**, locate the **Domain Selection** section.
- 3 From the **Selection** list, choose **Cooling Channels and Manifolds**.  
Use linear elements to match the element order of the other interfaces, and to save some memory and computational time.
- 4 Click to expand the **Discretization** section. From the **Pressure** list, choose **Linear**.

#### *Porous Matrix 1*

- 1 In the **Model Builder** window, under **Component 1 (comp1) > Darcy's Law (dl) > Porous Medium 1** click **Porous Matrix 1**.
- 2 In the **Settings** window for **Porous Matrix**, locate the **Matrix Properties** section.
- 3 From the  $\epsilon_p$  list, choose **User defined**. In the associated text field, type `eps_1_BPP`.
- 4 From the  $\kappa$  list, choose **User defined**. In the associated text field, type `perm_cool_BPP`.

#### *Inlet 1*

- 1 In the **Physics** toolbar, click  **Boundaries** and choose **Inlet**.
- 2 In the **Settings** window for **Inlet**, locate the **Boundary Selection** section.
- 3 From the **Selection** list, choose **Cooling Inlets**.
- 4 Locate the **Velocity** section. In the  $U_0$  text field, type `v_cool_in`.

#### *Outlet 1*

- 1 In the **Physics** toolbar, click  **Boundaries** and choose **Outlet**.

- 2 In the **Settings** window for **Outlet**, locate the **Boundary Selection** section.
- 3 From the **Selection** list, choose **Cooling Outlets**.
- 4 Locate the **Boundary Condition** section. From the **Boundary condition** list, choose **Pressure**.
- 5 In the **Model Builder** window, collapse the **Darcy's Law (dl)** node.

### HEAT TRANSFER IN POROUS MEDIA (HT)

In the **Model Builder** window, under **Component 1 (comp1)** click **Heat Transfer in Porous Media (ht)**.

#### *Solid 1 - Membranes*

- 1 In the **Physics** toolbar, click  **Domains** and choose **Solid**.
- 2 In the **Settings** window for **Solid**, type Solid 1 - Membranes in the **Label** text field.
- 3 Locate the **Domain Selection** section. From the **Selection** list, choose **Membranes**.  
Since the model is stationary, the density and heat capacity need not to be defined.
- 4 Locate the **Thermodynamics, Solid** section. From the  $\rho$  list, choose **User defined**. From the  $C_p$  list, choose **User defined**.

#### *Solid 2 - GDLs*

- 1 In the **Physics** toolbar, click  **Domains** and choose **Solid**.
- 2 In the **Settings** window for **Solid**, type Solid 2 - GDLs in the **Label** text field.
- 3 Locate the **Domain Selection** section. From the **Selection** list, choose **GDLs**.
- 4 Locate the **Heat Conduction, Solid** section. From the  $k$  list, choose **User defined**. The thermal conductivity of the gas diffusion layers is anisotropic, featuring a higher conductivity in the in-plane direction.
- 5 From the list, choose **Diagonal**.
- 6 Specify the  $k$  matrix as

|              |              |              |
|--------------|--------------|--------------|
| kappa_GDL_IP | 0            | 0            |
| 0            | kappa_GDL_IP | 0            |
| 0            | 0            | kappa_GDL_TP |

- 7 Locate the **Thermodynamics, Solid** section. From the  $\rho$  list, choose **User defined**. From the  $C_p$  list, choose **User defined**.

#### *Solid 3 - End Blocks*

- 1 In the **Physics** toolbar, click  **Domains** and choose **Solid**.

- 2 In the **Settings** window for **Solid**, type Solid 3 - End Blocks in the **Label** text field.
- 3 Locate the **Domain Selection** section. From the **Selection** list, choose **Current Collector and Feeder Plates**.

#### *Solid 4 - Gas Manifolds*

- 1 In the **Physics** toolbar, click  **Domains** and choose **Solid**.
- 2 In the **Settings** window for **Solid**, type Solid 4 - Gas Manifolds in the **Label** text field.
- 3 Locate the **Domain Selection** section. From the **Selection** list, choose **Gas Manifolds**.
- 4 Locate the **Heat Conduction, Solid** section. From the  $k$  list, choose **User defined**. In the associated text field, type  $\kappa_{\text{BPP\_eff}}$ .
- 5 Locate the **Thermodynamics, Solid** section. From the  $\rho$  list, choose **User defined**. From the  $C_p$  list, choose **User defined**.

#### *Porous Medium 1*

Couple the heat transfer to the velocity in the cooling channels as follows:

#### *Fluid 1*

- 1 In the **Model Builder** window, click **Fluid 1**.
- 2 In the **Settings** window for **Fluid**, locate the **Heat Convection** section.
- 3 From the  $\mathbf{u}$  list, choose **Total Darcy velocity field (dl/porous1)**.

#### *Porous Matrix 1*

- 1 In the **Model Builder** window, click **Porous Matrix 1**.
- 2 In the **Settings** window for **Porous Matrix**, locate the **Matrix Properties** section.
- 3 From the  $\epsilon_p$  list, choose **User defined**. In the associated text field, type  $\epsilon_{\text{p\_gas\_BPP}}$ .
- 4 Locate the **Thermodynamics, Porous Matrix** section. From the  $\rho_b$  list, choose **User defined**. Locate the **Heat Conduction, Porous Matrix** section. From the  $k_b$  list, choose **User defined**. In the associated text field, type  $\kappa_{\text{BPP\_eff}}$ .
- 5 Locate the **Thermodynamics, Porous Matrix** section. From the  $C_{p,b}$  list, choose **User defined**.

#### *Inflow 1*

- 1 In the **Physics** toolbar, click  **Boundaries** and choose **Inflow**.
- 2 In the **Settings** window for **Inflow**, locate the **Boundary Selection** section.
- 3 From the **Selection** list, choose **Cooling Inlets**.
- 4 Locate the **Upstream Properties** section. In the  $T_{\text{ustr}}$  text field, type  $T_{\text{in}}$ .

### *Outflow 1*

- 1 In the **Physics** toolbar, click  **Boundaries** and choose **Outflow**.
- 2 In the **Settings** window for **Outflow**, locate the **Boundary Selection** section.
- 3 From the **Selection** list, choose **Cooling Outlets**.

### *Initial Values 1*

- 1 In the **Model Builder** window, click **Initial Values 1**.
- 2 In the **Settings** window for **Initial Values**, locate the **Initial Values** section.
- 3 In the  $T$  text field, type  $T_{in}$ .
- 4 In the **Model Builder** window, collapse the **Heat Transfer in Porous Media (ht)** node.

## **MULTIPHYSICS**

Couple the heat sources in the fuel cell interface with heat transfer as follows. This will also couple the temperature defined by heat transfer to the fuel cell interface.

### *Electrochemical Heating 1 (ech1)*

- In the **Physics** toolbar, click  **Multiphysics Couplings** and choose **Domain > Electrochemical Heating**.

## **MESH 1**

Use a user-defined mesh for this model. The mesh sequence is based on sweeping the mesh in the through-plane direction of the stack. Since the model is finalized as an assembly in the geometry sequence, with assembly pairs located in the middle of the membranes, the mesh nodes do not need match along these boundaries.

### *Size 1*

- 1 In the **Model Builder** window, under **Component 1 (comp1)** right-click **Mesh 1** and choose **Size**.
- 2 In the **Settings** window for **Size**, locate the **Geometric Entity Selection** section.
- 3 From the **Geometric entity level** list, choose **Boundary**.
- 4 From the **Selection** list, choose **Membrane Boundaries**.
- 5 Locate the **Element Size** section. Click the **Custom** button.
- 6 Locate the **Element Size Parameters** section.
- 7 Select the **Maximum element size** checkbox. In the associated text field, type  $2.5e-3$ .

### *Swept 1*

- 1 In the **Mesh** toolbar, click  **Swept**.
- 2 In the **Settings** window for **Swept**, locate the **Domain Selection** section.

- 3 From the **Geometric entity level** list, choose **Domain**.
- 4 From the **Selection** list, choose **Membranes**.
- 5 Click to expand the **Source Faces** section. From the **Selection** list, choose **Hydrogen Gas Diffusion Electrodes**.
- 6 Click to expand the **Destination Faces** section. From the **Selection** list, choose **Oxygen Gas Diffusion Electrodes**.
- 7 Locate the **Mesh Generation** section. From the **Elements** list, choose **Prisms**.

#### *Distribution 1*

- 1 Right-click **Swept 1** and choose **Distribution**.
- 2 In the **Settings** window for **Distribution**, locate the **Distribution** section.
- 3 In the **Number of elements** text field, type 2.

#### *Size*

- 1 In the **Model Builder** window, under **Component 1 (comp1) > Mesh 1** click **Size**.
- 2 In the **Settings** window for **Size**, locate the **Element Size** section.
- 3 From the **Predefined** list, choose **Extremely fine**.
- 4 Click  **Build All**.

### **DEFINITIONS**

To facilitate viewing when setting up the sequence, add a **View** with scaling in the **z** direction.

#### *View 8*

In the **Model Builder** window, under **Component 1 (comp1)** right-click **Definitions** and choose **View**.

#### *Camera*

- 1 In the **Model Builder** window, expand the **View 8** node, then click **Camera**.
- 2 In the **Settings** window for **Camera**, locate the **Camera** section.
- 3 From the **View scale** list, choose **Manual**.
- 4 In the **z scale** text field, type 50.

5 Click  **Update**.

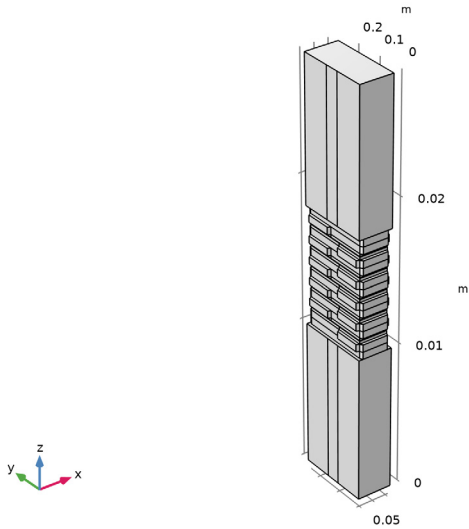

#### *Hide for Physics 1*

- 1 In the **Model Builder** window, right-click **View 8** and choose **Hide for Physics**.
- 2 In the **Settings** window for **Hide for Physics**, locate the **Geometric Entity Selection** section.
- 3 From the **Selection** list, choose **Current Collector and Feeder Plates**.

#### **MESH 1**

Click the  **Zoom Extents** button in the **Graphics** toolbar.

#### *Swept 2*

- 1 In the **Mesh** toolbar, click  **Swept**.
- 2 In the **Settings** window for **Swept**, locate the **Domain Selection** section.
- 3 From the **Geometric entity level** list, choose **Domain**.
- 4 From the **Selection** list, choose **Oxygen GDLs**.

#### *Distribution 1*

- 1 Right-click **Swept 2** and choose **Distribution**.

2 Right-click **Distribution 1** and choose **Build Selected**.

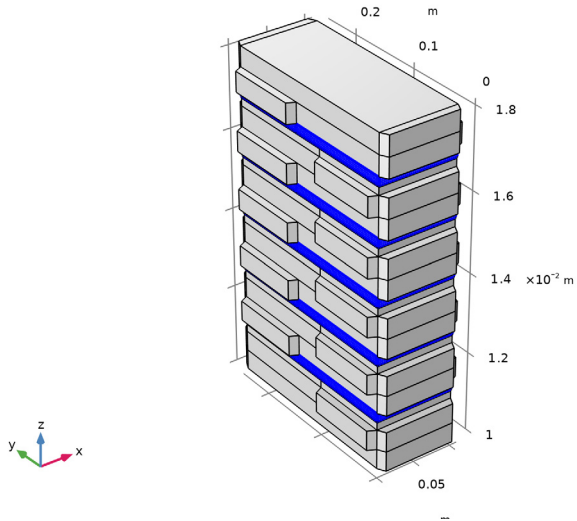

### *Swept 3*

- 1 In the **Mesh** toolbar, click  **Swept**.
- 2 In the **Settings** window for **Swept**, locate the **Domain Selection** section.
- 3 From the **Geometric entity level** list, choose **Domain**.
- 4 From the **Selection** list, choose **Hydrogen GDLs**.

### *Distribution 1*

- 1 Right-click **Swept 3** and choose **Distribution**.

2 Right-click **Distribution 1** and choose **Build Selected**.

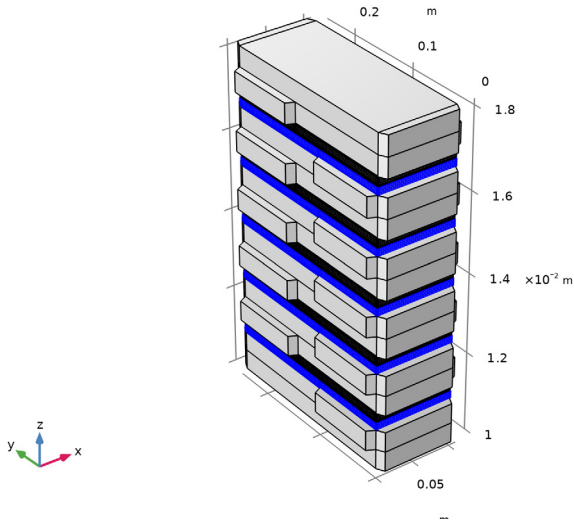

#### *Swept 4*

- 1 In the **Mesh** toolbar, click  **Swept**.
- 2 In the **Settings** window for **Swept**, locate the **Domain Selection** section.
- 3 From the **Geometric entity level** list, choose **Domain**.
- 4 From the **Selection** list, choose **Cooling Channels and Manifolds**.

#### *Distribution 1*

- 1 Right-click **Swept 4** and choose **Distribution**.
- 2 In the **Settings** window for **Distribution**, locate the **Distribution** section.
- 3 In the **Number of elements** text field, type 2.

4 Click  **Build Selected**.

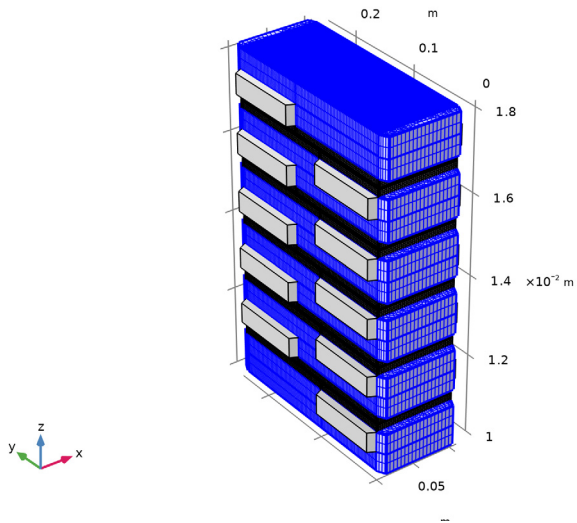

*Swept 5*



In the **Mesh** toolbar, click  **Swept**.

*Distribution 1*

- 1 Right-click **Swept 5** and choose **Distribution**.
- 2 In the **Settings** window for **Distribution**, locate the **Distribution** section.
- 3 In the **Number of elements** text field, type 2.

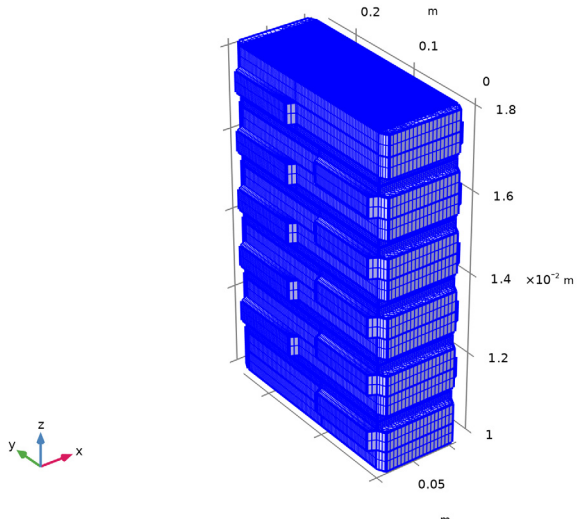
4 Click  **Build Selected.**



5 In the **Graphics** window toolbar, click  next to  **Go to Default View**, then choose **Go to View I.**

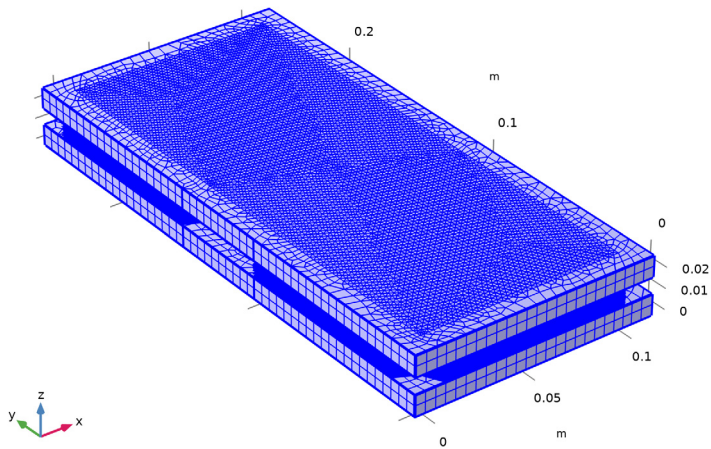

6 Click the  **Zoom Extents** button in the **Graphics** toolbar.

## STUDY 1

Now start setting up the study sequence.

The first initialization step solves for a primary current distribution, that is, a simplified set of the fuel cell equations, not including activation or concentration overpotentials.

Add a second initialization step solves that solves for a secondary current distribution, which includes activation but not concentration overpotentials. The second step will use the results of the first step as initial values for the dependent variables.

### Step 3: Current Distribution Initialization 2

- 1 In the **Study** toolbar, click  **More Study Steps** and choose **Other > Current Distribution Initialization**.
- 2 Right-click **Step 3: Current Distribution Initialization 2** and choose **Move Up**.
- 3 In the **Settings** window for **Current Distribution Initialization**, locate the **Study Settings** section.
- 4 From the **Current distribution type** list, choose **Secondary**.

### Step 3: Stationary

The third step we will use to only solve for the pressures in the fuel cell interface. Specifying that we will only solve for the pressures will be done later.

- 1 In the **Model Builder** window, click **Step 3: Stationary**.
- 2 In the **Settings** window for **Stationary**, locate the **Physics and Variables Selection** section.
- 3 In the **Solve for** column of the table, under **Component 1 (comp1)**, select the checkbox for **Hydrogen Fuel Cell (fc)**.
- 4 In the **Solve for** column of the table, under **Component 1 (comp1)**, clear the checkboxes for **Darcy's Law (dl)** and **Heat Transfer in Porous Media (ht)**.



### Step 4: Stationary 2

Add a fourth step to only solve for the convective cooling flow (Darcy's Law).

- 1 In the **Study** toolbar, click  **Stationary**.
- 2 In the **Settings** window for **Stationary**, locate the **Physics and Variables Selection** section.
- 3 In the **Solve for** column of the table, under **Component 1 (comp1)**, clear the checkbox for **Hydrogen Fuel Cell (fc)**.
- 4 In the **Solve for** column of the table, under **Component 1 (comp1)**, select the checkbox for **Darcy's Law (dl)**.
- 5 In the **Solve for** column of the table, under **Component 1 (comp1)**, clear the checkbox for **Heat Transfer in Porous Media (ht)**.

### Step 5: Stationary 3

Add a fifth step which we will use to compute the final solution, for a range of potentials. We will assume the convective cooling flow (Darcy's Law) not to be affected by the temperature, and hence we need not to solve for it in this step.

- 1 In the **Study** toolbar, click  **Stationary**.
- 2 In the **Settings** window for **Stationary**, locate the **Physics and Variables Selection** section.
- 3 In the **Solve for** column of the table, under **Component 1 (comp1)**, select the checkbox for **Hydrogen Fuel Cell (fc)**.
- 4 In the **Solve for** column of the table, under **Component 1 (comp1)**, clear the checkbox for **Darcy's Law (dl)**.
- 5 In the **Solve for** column of the table, under **Component 1 (comp1)**, select the checkbox for **Heat Transfer in Porous Media (ht)**.
- 6 Click to expand the **Study Extensions** section. Select the **Auxiliary sweep** checkbox.
- 7 Click  **Add**.
- 8 In the table, enter the following settings:

| Parameter name                    | Parameter value list | Parameter unit |
|-----------------------------------|----------------------|----------------|
| E_cell_avg (Average cell voltage) |                      | V              |

- 9 In the table, click to select the cell at row number 1 and column number 3.
- 10 Click  **Range**.
- 11 In the **Range** dialog, type E\_cell\_avg\_start in the **Start** text field.
- 12 In the **Step** text field, type -0.1.
- 13 In the **Stop** text field, type 0.55.
- 14 Click **Replace**.

### Solution 1 (sol1)

Set the third step to solve only for the fuel cell pressures as follows:



- 1 In the **Study** toolbar, click  **Show Default Solver**.
- 2 In the **Model Builder** window, expand the **Solution 1 (sol1)** node, then click **Dependent Variables 3**.
- 3 In the **Settings** window for **Dependent Variables**, locate the **General** section.
- 4 From the **Defined by study step** list, choose **User defined**.

- 5 In the **Model Builder** window, expand the **Study 1 > Solver Configurations > Solution 1 (sol1) > Dependent Variables 3** node, then click **Chemical Potential (comp1.fc.mu0)**.
- 6 In the **Settings** window for **Field**, locate the **General** section.
- 7 Clear the **Solve for this field** checkbox.
- 8 In the **Model Builder** window, under **Study 1 > Solver Configurations > Solution 1 (sol1) > Dependent Variables 3** click **Electrolyte Potential (comp1.fc.phil)**.
- 9 In the **Settings** window for **Field**, locate the **General** section.
- 10 Clear the **Solve for this field** checkbox.
- 11 In the **Model Builder** window, under **Study 1 > Solver Configurations > Solution 1 (sol1) > Dependent Variables 3** click **Electric Potential (comp1.fc.phis)**.
- 12 In the **Settings** window for **Field**, locate the **General** section.
- 13 Clear the **Solve for this field** checkbox.
- 14 In the **Model Builder** window, under **Study 1 > Solver Configurations > Solution 1 (sol1) > Dependent Variables 3** click **Mass Fraction (comp1.fc.wH2O\_H2)**.
- 15 In the **Settings** window for **Field**, locate the **General** section.
- 16 Clear the **Solve for this field** checkbox.
- 17 In the **Model Builder** window, under **Study 1 > Solver Configurations > Solution 1 (sol1) > Dependent Variables 3** click **Mass Fraction (comp1.fc.wH2O\_O2)**.
- 18 In the **Settings** window for **Field**, locate the **General** section.
- 19 Clear the **Solve for this field** checkbox.
- 20 In the **Model Builder** window, under **Study 1 > Solver Configurations > Solution 1 (sol1) > Dependent Variables 3** click **Mass Fraction (comp1.fc.wN2\_O2)**.
- 21 In the **Settings** window for **Field**, locate the **General** section.
- 22 Clear the **Solve for this field** checkbox.
- 23 In the **Study** toolbar, click  **Compute**.

## RESULTS

Set default units for result presentation.

### *Preferred Units 1*

- 1 In the **Results** toolbar, click  **Configurations** and choose **Preferred Units**.
- 2 In the **Settings** window for **Preferred Units**, locate the **Units** section.
- 3 Click  **Add Physical Quantity**.

- 4 In the **Physical Quantity** dialog, select **General > Temperature (K)** in the tree.
- 5 Click **OK**.
- 6 In the **Settings** window for **Preferred Units**, locate the **Units** section.
- 7 In the table, enter the following settings:

| Quantity    | Unit | Preferred unit |
|-------------|------|----------------|
| Temperature | K    | °C             |

- 8 In the **Model Builder** window, click **Preferred Units I**.
- 9 Click  **Apply**.

#### *Electrode Potential with Respect to Ground (fc)*

Reproduce the figures from the Results and Discussion section as follows:

- 1 In the **Model Builder** window, expand the **Electrode Potential with Respect to Ground (fc)** node.

#### *Arrow Volume I, Multislice I*

- 1 In the **Model Builder** window, under **Results > Electrode Potential with Respect to Ground (fc)**, Ctrl-click to select **Multislice I** and **Arrow Volume I**.
- 2 Right-click and choose **Disable**.

#### *Electrode Potential with Respect to Ground (fc)*

- 1 In the **Model Builder** window, click **Electrode Potential with Respect to Ground (fc)**.
- 2 In the **Settings** window for **3D Plot Group**, locate the **Plot Settings** section.
- 3 Clear the **Plot dataset edges** checkbox.

#### *Surface I*

- 1 Right-click **Electrode Potential with Respect to Ground (fc)** and choose **Surface**.
- 2 In the **Settings** window for **Surface**, click **Replace Expression** in the upper-right corner of the **Expression** section. From the menu, choose **Component I (comp1) > Hydrogen Fuel Cell > fc.phis - Electric potential - V**.
- 3 Click to expand the **Coloring and Style** section. From the **Color table** list, choose **Cyananthus**.

- 4 In the **Electrode Potential with Respect to Ground (fc)** toolbar, click  **Plot**.

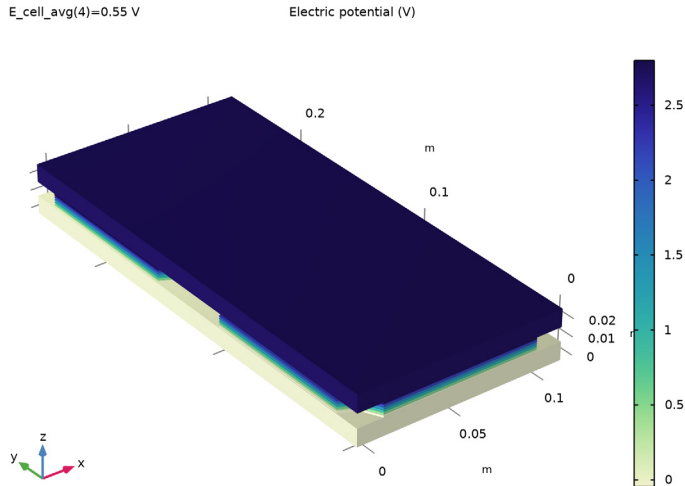

#### *Mole Fraction, H2, Surface (fc)*

- 1 In the **Model Builder** window, under **Results** click **Mole Fraction, H2, Surface (fc)**.
- 2 In the **Settings** window for **3D Plot Group**, locate the **Plot Settings** section.
- 3 Clear the **Plot dataset edges** checkbox.

#### *Surface 1*

- 1 In the **Model Builder** window, expand the **Mole Fraction, H2, Surface (fc)** node, then click **Surface 1**.
- 2 In the **Settings** window for **Surface**, locate the **Coloring and Style** section.
- 3 From the **Color table** list, choose **Cyanthus**.

4 In the **Mole Fraction, H2, Surface (fc)** toolbar, click  **Plot**.

E\_cell\_avg(4)=0.55 V

Species H2: Mole fraction (1)

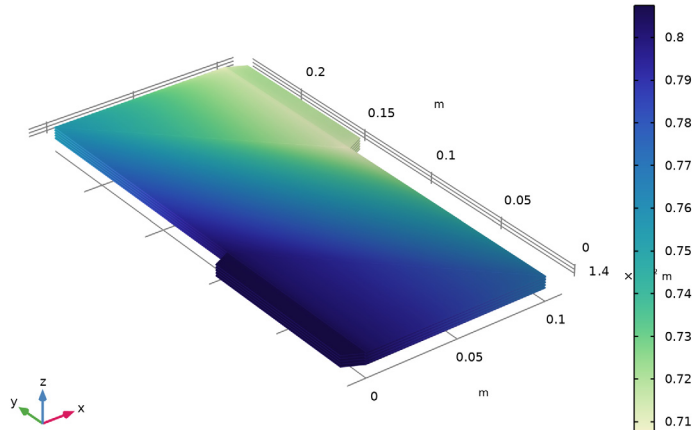

#### *Mole Fraction, O2, Surface (fc)*

- 1 In the **Model Builder** window, under **Results** click **Mole Fraction, O2, Surface (fc)**.
- 2 In the **Settings** window for **3D Plot Group**, locate the **Plot Settings** section.
- 3 Clear the **Plot dataset edges** checkbox.

#### *Surface 1*

- 1 In the **Model Builder** window, expand the **Mole Fraction, O2, Surface (fc)** node, then click **Surface 1**.
- 2 In the **Settings** window for **Surface**, click to expand the **Coloring and Style** section.
- 3 From the **Color table** list, choose **Cyanthus**.

4 In the **Mole Fraction, O<sub>2</sub>, Surface (fc)** toolbar, click  **Plot**.

E\_cell\_avg(4)=0.55 V

Species O2: Mole fraction (1)

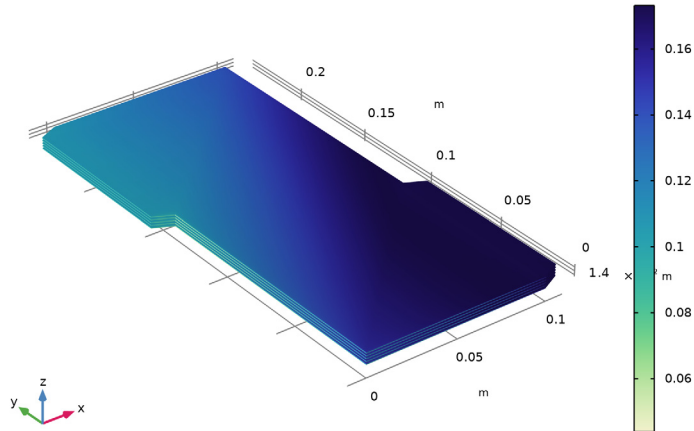

#### *Multislice 1*

- 1 In the **Model Builder** window, expand the **Water Activity (Relative Humidity) (fc)** node.
- 2 Right-click **Multislice 1** and choose **Disable**.

#### *Water Activity in Oxygen GDEs*

- 1 In the **Model Builder** window, under **Results** click **Water Activity (Relative Humidity) (fc)**.
- 2 In the **Settings** window for **3D Plot Group**, type Water Activity in Oxygen GDEs in the **Label** text field.
- 3 Click to expand the **Title** section. From the **Title type** list, choose **Label**.

#### *Surface 1*

- 1 Right-click **Water Activity in Oxygen GDEs** and choose **Surface**.
- 2 In the **Settings** window for **Surface**, click **Replace Expression** in the upper-right corner of the **Expression** section. From the menu, choose **Component 1 (comp1) > Hydrogen Fuel Cell > fc.aw - Water activity (relative humidity) - 1**.
- 3 Click to expand the **Coloring and Style** section. From the **Color table** list, choose **Cyanthus**.

#### *Selection 1*

- 1 Right-click **Surface 1** and choose **Selection**.
- 2 In the **Settings** window for **Selection**, locate the **Selection** section.

3 From the **Selection** list, choose **Oxygen Gas Diffusion Electrodes**.

#### *Water Activity in Oxygen GDEs*

- 1 In the **Model Builder** window, under **Results** click **Water Activity in Oxygen GDEs**.
- 2 In the **Settings** window for **3D Plot Group**, locate the **Plot Settings** section.
- 3 Clear the **Plot dataset edges** checkbox.
- 4 In the **Water Activity in Oxygen GDEs** toolbar, click  **Plot**.

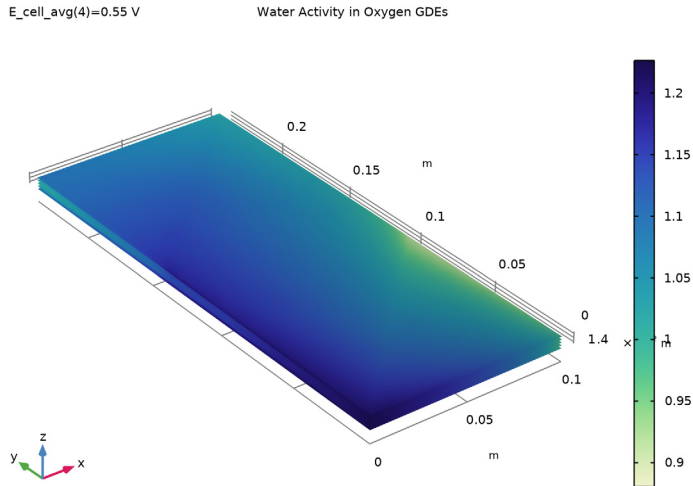

#### *Temperature in MEAs*

- 1 In the **Results** toolbar, click  **3D Plot Group**.
- 2 In the **Settings** window for **3D Plot Group**, type **Temperature in MEAs** in the **Label** text field.
- 3 Locate the **Plot Settings** section. Clear the **Plot dataset edges** checkbox.

#### *Surface 1*

- 1 Right-click **Temperature in MEAs** and choose **Surface**.
- 2 In the **Settings** window for **Surface**, click **Replace Expression** in the upper-right corner of the **Expression** section. From the menu, choose **Component 1 (comp1) > Heat Transfer in Porous Media > Temperature > T - Temperature - K**.
- 3 Locate the **Coloring and Style** section. From the **Color table** list, choose **HeatCameraLight**.

### Selection 1

- 1 Right-click **Surface 1** and choose **Selection**.
- 2 In the **Settings** window for **Selection**, locate the **Selection** section.
- 3 From the **Geometric entity level** list, choose **Domain**.
- 4 From the **Selection** list, choose **GDLs**.

### Surface 2

- 1 In the **Model Builder** window, under **Results > Temperature in MEAs** right-click **Surface 1** and choose **Duplicate**.
- 2 In the **Settings** window for **Surface**, click to expand the **Title** section.
- 3 From the **Title type** list, choose **None**.
- 4 Click to expand the **Inherit Style** section. From the **Plot** list, choose **Surface 1**.

### Selection 1

- 1 In the **Model Builder** window, expand the **Surface 2** node, then click **Selection 1**.
- 2 In the **Settings** window for **Selection**, locate the **Selection** section.
- 3 From the **Selection** list, choose **Membranes**.
- 4 In the **Temperature in MEAs** toolbar, click  **Plot**.

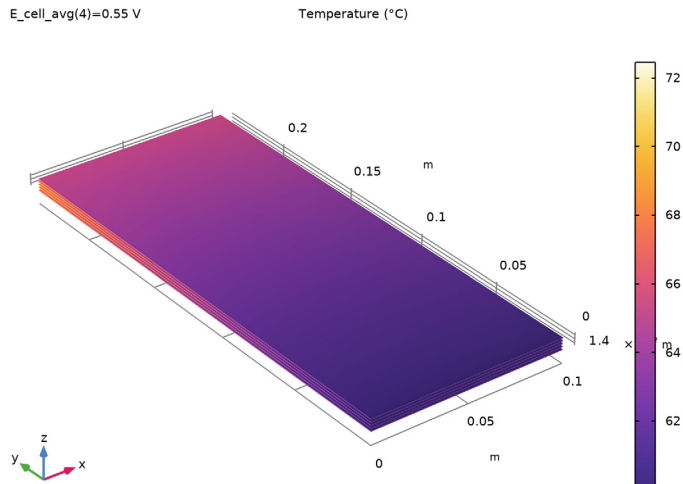

### Temperature in Cooling Channels

- 1 In the **Results** toolbar, click  **3D Plot Group**.

- 2 In the **Settings** window for **3D Plot Group**, type **Temperature** in **Cooling Channels** in the **Label** text field.
- 3 Locate the **Title** section. From the **Title type** list, choose **Label**.
- 4 Locate the **Plot Settings** section. Clear the **Plot dataset edges** checkbox.
- 5 Locate the **Color Legend** section. Select the **Show units** checkbox.

#### *Streamline Multislice 1*

- 1 In the **Temperature in Cooling Channels** toolbar, click  **More Plots** and choose **Streamline Multislice**.
- 2 In the **Settings** window for **Streamline Multislice**, click **Replace Expression** in the upper-right corner of the **Expression** section. From the menu, choose **Component 1 (comp1) > Darcy's Law > Velocity and pressure > dl.u,dl.v,dl.w - Total Darcy velocity field**.
- 3 Locate the **Multiplane Data** section. Find the **X-planes** subsection. In the **Planes** text field, type 0.
- 4 Find the **Y-planes** subsection. In the **Planes** text field, type 0.
- 5 Find the **Z-planes** subsection. From the **Entry method** list, choose **Coordinates**.
- 6 In the **Coordinates** text field, type  $\text{range}(D_{cc}+D_{bpp}*0.5, D_{cell}, D_{cc}+D_{bpp}*0.5+N_{cells}*D_{cell})$ .
- 7 Locate the **Streamline Positioning** section. From the **Positioning** list, choose **Uniform density**.
- 8 Locate the **Coloring and Style** section. Find the **Point style** subsection. From the **Type** list, choose **Arrow**.
- 9 From the **Arrow distribution** list, choose **Equal inverse time**.

#### *Color Expression 1*

- 1 Right-click **Streamline Multislice 1** and choose **Color Expression**.
- 2 In the **Settings** window for **Color Expression**, click **Replace Expression** in the upper-right corner of the **Expression** section. From the menu, choose **Component 1 (comp1) > Heat Transfer in Porous Media > Temperature > T - Temperature - K**.

- 3 Locate the **Coloring and Style** section. From the **Color table** list, choose **HeatCameraLight**.

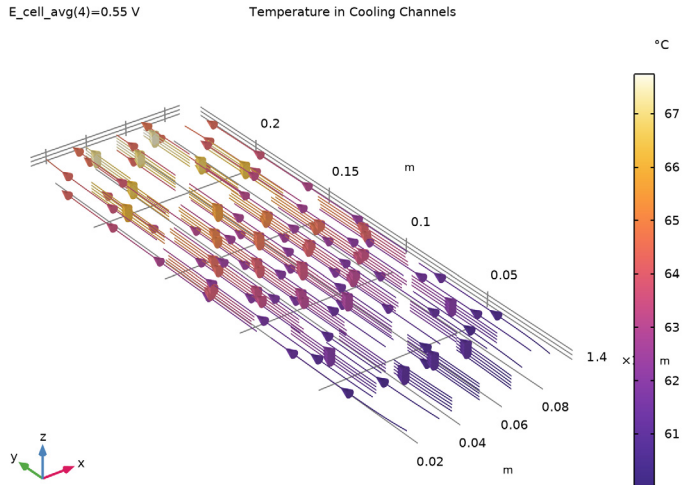

#### *Cut Line 3D 1*

- 1 In the **Results** toolbar, click  **Cut Line 3D**.
- 2 In the **Settings** window for **Cut Line 3D**, locate the **Line Data** section.
- 3 In row **Point 1**, set **X** to  $W_{plate}/2$ .
- 4 In row **Point 1**, set **Y** to  $0.95*L_{plate}$ .
- 5 In row **Point 1**, set **Z** to  $D_{cc}$ .
- 6 In row **Point 2**, set **X** to  $W_{plate}/2$ .
- 7 In row **Point 2**, set **Y** to  $0.95*L_{plate}$ .
- 8 In row **Point 2**, set **Z** to  $D_{cc}+D_{cell}*N_{cells}+D_{bpp}$ .

#### *Mid-Stack Temperature Toward Cooling Outlets*

- 1 In the **Results** toolbar, click  **ID Plot Group**.
- 2 In the **Settings** window for **ID Plot Group**, type Mid-Stack Temperature Toward Cooling Outlets in the **Label** text field.
- 3 Click to expand the **Title** section. From the **Title type** list, choose **Label**.

#### *Line Graph 1*

Right-click **Mid-Stack Temperature Toward Cooling Outlets** and choose **Line Graph**.

### Mid-Stack Temperature Toward Cooling Outlets

Locate the **Data** section. From the **Dataset** list, choose **Cut Line 3D I**.

#### Line Graph 1

- 1 In the **Model Builder** window, click **Line Graph 1**.
- 2 In the **Settings** window for **Line Graph**, click **Replace Expression** in the upper-right corner of the **y-Axis Data** section. From the menu, choose **Component I (comp1) > Heat Transfer in Porous Media > Temperature > T - Temperature - K**.
- 3 Locate the **x-Axis Data** section. From the **Parameter** list, choose **Expression**.
- 4 In the **Expression** text field, type **z**.
- 5 Click to expand the **Legends** section. Select the **Show legends** checkbox.
- 6 In the **Mid-Stack Temperature Toward Cooling Outlets** toolbar, click  **Plot**.

