



Model created in COMSOL Multiphysics 6.4

# High Temperature PEM Fuel Cell with Serpentine Flow Field

## *Introduction*

---

The design of the fuel cell flow pattern governs the fuel utilization, the current distribution, and the pressure drop in the cell. A common design approach is to use serpentine channels in order to evenly distribute the reacting fluid over the electrode area. The serpentine design has the advantage of creating a set of parallel channels of equal length and similar flow resistances for a small inlet manifold. However, the design may induce unnecessarily high pressure drops. Also, for low temperature fuel cells, clogging due to water condensation may occur in the serpentine bends.

For the serpentine channel design to work properly, the channel-to-channel cross-flow, due to in-plane convection in the underlying porous material layer, should be moderate, since large cross-flow may lead to stagnant zones and uneven flow between the channels.

This example describes the cathode airflow and mass transport in three serpentine channels and the underlying gas diffusion layer (GDL) of a polymer electrolyte fuel cell.

The same model parameters are used as in the [Mass Transport Analysis of a High Temperature PEM Fuel Cell](#) example.

## *Model Definition*

---

The model geometry is shown in [Figure 1](#). The model consists of three channel domains on the cathode (oxygen) side, and the underlying cathode GDL, membrane, and anode GDL domains. The channel inlets are on the left and the outlets on the right. The bottom

anode GDL boundary faces the anode flow channels which are not included in the model geometry.

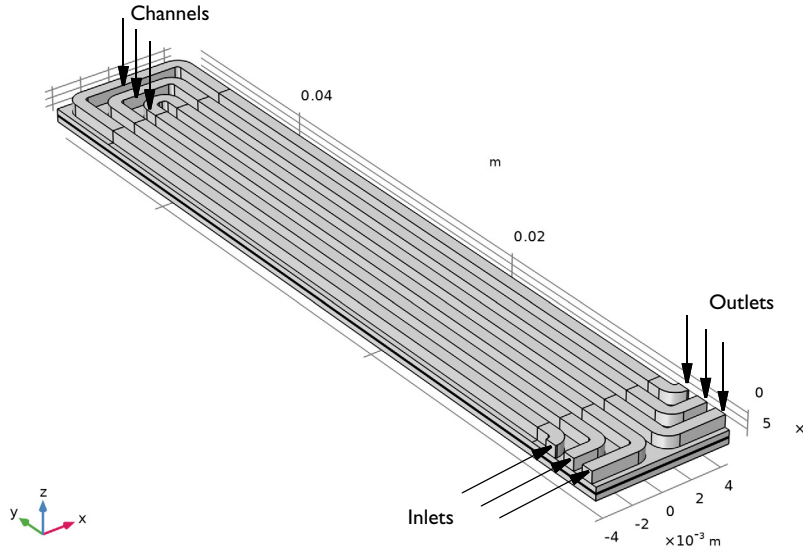
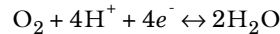

Figure 1: Model geometry.

The current distribution and the mass transport are modeled using a Hydrogen Fuel Cell interface. This physics interface solves for the electrolyte and electrode phase potentials, as well as the molar fraction of oxygen, nitrogen and water on the cathode side. The momentum transfer is solved for using a Free and Porous Media flow, Brinkman interface. This physics interface solves for the fluid velocity and pressures. The fuel cell and the flow interfaces are coupled together using a Reacting Flow, O<sub>2</sub> Gas Phase which couples the velocity field, pressure gradient as well as the composition dependent density and viscosity between the two interfaces.

The porous cathode reaction reduces oxygen according to



This reaction is modeled as a Thin Gas Diffusion Electrode in combination with a Thin Gas Diffusion Electrode Reaction subnode. The local current density,  $i_{loc}$  (SI unit: A/m<sup>2</sup>) depends on the oxygen concentration and the local overpotential according to the following kinetic expression:

$$i_{loc} = i_{0,ref} \left( \left( \frac{P_{H2O}}{p_{ref}} \right)^2 \exp\left(\frac{\alpha_a}{RT} F \eta_c\right) - \left( \frac{P_{O2}}{p_{ref}} \right) \exp\left(-\frac{\alpha_c}{RT} F \eta_c\right) \right)$$

O2 Inlet and O2 Outlet are used on the inlet and outlet boundaries, respectively. No slip wall conditions are used for the channel walls, whereas slip conditions are used for the GDL walls.

On the anode side, the gas stream is assumed to be unaffected by the electrode reactions in the cell, consisting of 100% hydrogen within the whole of the anode GDL and gas diffusion electrode.

The anode current collector boundary is grounded, whereas a cell potential is prescribed to the cathode current collector boundaries.

The mesh is shown in [Figure 2](#). The bottom channel, and the GDL area between the serpentine bend of the bottom channel have a finer mesh in order to resolve the channel-to-channel cross-flow.

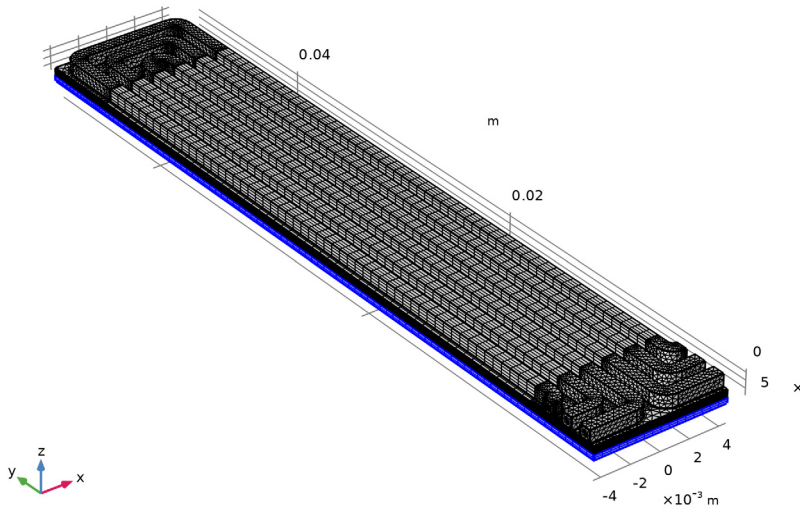

*Figure 2: Mesh.*

The problem is solved in three consecutive study steps: The first step solves for the potentials only, the second step solves for the velocity and pressure only, and the final step solves for the full problem, solving for the cell potentials 0.9, 0.7, and 0.5 V.

## Notes About the COMSOL Implementation

The geometry is set up using an assembly of two different parts with an identity pair coupling in the middle of the membrane. The reason for this is to be able to have different swept meshes on each side of the membrane. The identity pair and the corresponding Continuity boundary condition nodes in the Hydrogen Fuel Cell interface is added automatically by default.

## Results and Discussion

Figure 3 shows the velocity magnitude in the cell. There is a small channel-to-channel leakage in the GDL.

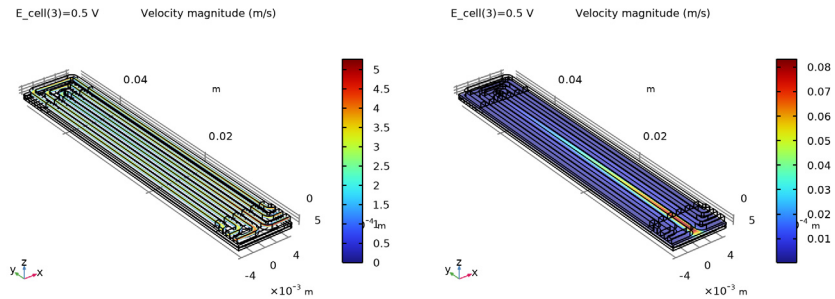

Figure 3: Velocity magnitude. Left: Slice plot in the middle of the channels. Right: Slice plot in the middle of the GDL.

Figure 4 shows the oxygen molar fraction in the gas stream at a cell voltage at 0.7 and 0.5 V. The oxygen level decreases toward the outlet in both cases, with generally lower levels at 0.5 V.

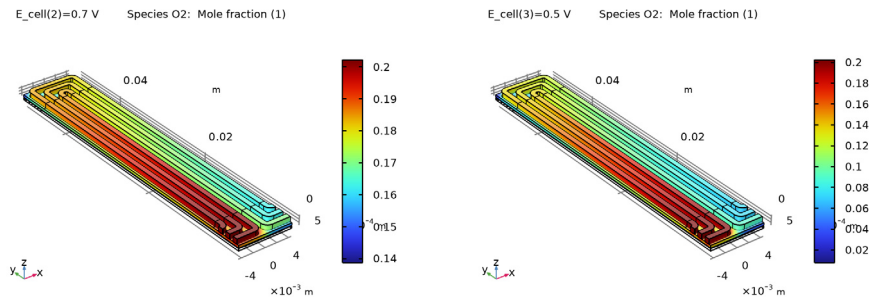

Figure 4: Oxygen mole fraction at 0.7 V (left) and 0.5 V (right).

Figure 5 shows the corresponding electrolyte current density in the  $z$  direction at the cathode. The current densities are generally higher at 0.5 V, and less uniform. The current densities decrease toward the outlet which can be explained by the lower oxygen concentration levels shown in Figure 4. A minor effect of the GDL channel-to-channel leakage flow can be observed.

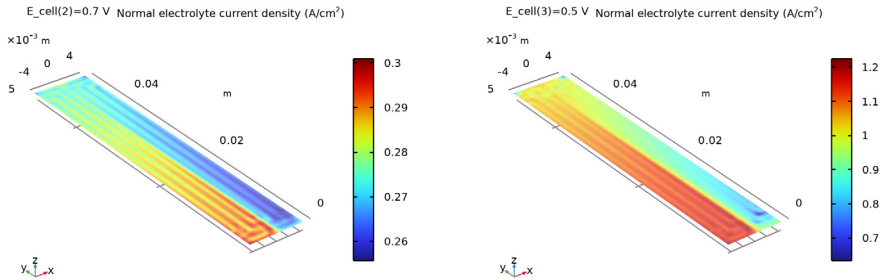

Figure 5: Electrolyte current density at the cathode in the  $z$  direction at 0.7 V (left) and 0.5 V (right).

---

**Application Library path:** Fuel\_Cell\_and\_Electrolyzer\_Module/Fuel\_Cells/ht\_pem\_flow\_field

---

### *Modeling Instructions*

---



From the **File** menu, choose **New**.

#### **NEW**

In the **New** window, click  **Model Wizard**.

#### **MODEL WIZARD**

- 1 In the **Model Wizard** window, click  **3D**.
- 2 In the **Select Physics** tree, select **Electrochemistry > Hydrogen Fuel Cells > Proton Exchange Membrane (fc)**.
- 3 Click **Add**.
- 4 In the **Select Physics** tree, select **Fluid Flow > Porous Media and Subsurface Flow > Free and Porous Media Flow, Brinkman (fp)**.

- 5 Click **Add**.
- 6 Click  **Study**.
- 7 In the **Select Study** tree, select **Preset Studies for Selected Physics Interfaces > Hydrogen Fuel Cell > Stationary with Initialization**.
- 8 Click  **Done**.

### GEOMETRY I

The model geometry is available as a parameterized geometry sequence in a separate MPH file. If you want to build it from scratch, follow the instructions in the section [Appendix — Geometry Modeling Instructions](#). Otherwise load it from file with the following steps.

- 1 In the **Geometry** toolbar, click **Insert Sequence** and choose **Insert Sequence**.
- 2 Browse to the model's Application Libraries folder and double-click the file `ht_pem_flow_field_geom_sequence.mph`.
- 3 In the **Geometry** toolbar, click  **Build All**.
- 4 In the **Model Builder** window, under **Component I (comp1)** click **Geometry I**.

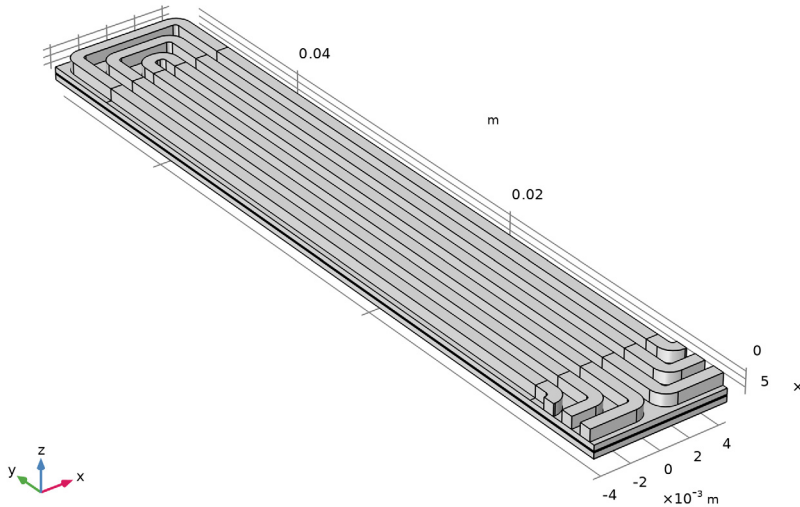

- 5 In the **Model Builder** window, collapse the **Geometry I** node.



## GLOBAL DEFINITIONS

The insertion of the geometry sequence added some parameters to the model. Load some additional physics parameters a text files.

### *Geometry Parameters*

- 1 In the **Model Builder** window, under **Global Definitions** click **Parameters I**.
- 2 In the **Settings** window for **Parameters**, type Geometry Parameters in the **Label** text field.

### *Physics Parameters*

- 1 In the **Home** toolbar, click  **Parameters** and choose **Add > Parameters**.
- 2 In the **Settings** window for **Parameters**, type Physics Parameters in the **Label** text field.
- 3 Locate the **Parameters** section. Click  **Load from File**.
- 4 Browse to the model's Application Libraries folder and double-click the file `ht_pem_flow_field_physics_parameters.txt`.

## MULTIPHYSICS

Start setting up the physics. First add a Multiphysics node to couple the two interfaces together.

### *Reacting Flow, O2 Gas Phase I (rfol)*

In the **Physics** toolbar, click  **Multiphysics Couplings** and choose **Domain > Reacting Flow, O2 Gas Phase**.

## HYDROGEN FUEL CELL (FC)

Next set up the **Hydrogen Fuel Cell** interface.

In this model, we will not model hydrogen transport on the anode side, assuming a gas consisting of 100% hydrogen.

- 1 In the **Model Builder** window, under **Component 1 (comp1)** click **Hydrogen Fuel Cell (fc)**.
- 2 In the **Settings** window for **Hydrogen Fuel Cell**, locate the **H2 Gas Mixture** section.
- 3 Clear the **H2O** checkbox.

### *Membrane I*

Start adding the different domain nodes of the fuel cell model, and assign them to the geometry.

- 1 In the **Physics** toolbar, click  **Domains** and choose **Membrane**.

2 In the **Settings** window for **Membrane**, locate the **Domain Selection** section.

3 From the **Selection** list, choose **Membrane**.

The named selections of the geometry for Membrane etc were created in the geometry sequence.

#### *H2 Gas Diffusion Layer 1*

1 In the **Physics** toolbar, click  **Domains** and choose **H2 Gas Diffusion Layer**.

2 In the **Settings** window for **H2 Gas Diffusion Layer**, locate the **Domain Selection** section.

3 From the **Selection** list, choose **H2 GDL**.

4 Locate the **Electrode Charge Transport** section. In the  $\sigma_s$  text field, type sigma\_gdl.

#### *O2 Gas Diffusion Layer 1*

1 In the **Physics** toolbar, click  **Domains** and choose **O2 Gas Diffusion Layer**.

2 In the **Settings** window for **O2 Gas Diffusion Layer**, locate the **Domain Selection** section.

3 From the **Selection** list, choose **O2 GDL**.

4 Locate the **Electrode Charge Transport** section. In the  $\sigma_s$  text field, type sigma\_gdl.

5 Locate the **Gas Transport** section. In the  $\epsilon_g$  text field, type eps\_gdl.

#### *Thin H2 Gas Diffusion Electrode 1*

1 In the **Physics** toolbar, click  **Boundaries** and choose **Thin H2 Gas Diffusion Electrode**.

2 In the **Settings** window for **Thin H2 Gas Diffusion Electrode**, locate the **Boundary Selection** section.

3 From the **Selection** list, choose **GDE, H2 Side**.

4 Locate the **Electrode Thickness** section. In the  $d_{gde}$  text field, type H\_electrode.

#### *Thin H2 Gas Diffusion Electrode Reaction 1*

1 In the **Model Builder** window, click **Thin H2 Gas Diffusion Electrode Reaction 1**.

2 In the **Settings** window for **Thin H2 Gas Diffusion Electrode Reaction**, locate the **Electrode Kinetics** section.

3 In the  $i_{0,ref}(T)$  text field, type i0\_H2\_ref.

4 In the  $\alpha_a$  text field, type alpha\_a\_H2.

5 Locate the **Active Specific Surface Area** section. In the  $a_v$  text field, type Av.

#### *Thin O2 Gas Diffusion Electrode 1*

1 In the **Physics** toolbar, click  **Boundaries** and choose **Thin O2 Gas Diffusion Electrode**.

2 In the **Settings** window for **Thin O2 Gas Diffusion Electrode**, locate the **Boundary Selection** section.

- 3 From the **Selection** list, choose **GDE, O2 Side**.
- 4 Locate the **Electrode Thickness** section. In the  $d_{gde}$  text field, type H\_electrode.

#### *Thin O2 Gas Diffusion Electrode Reaction I*

- 1 In the **Model Builder** window, click **Thin O2 Gas Diffusion Electrode Reaction I**.
- 2 In the **Settings** window for **Thin O2 Gas Diffusion Electrode Reaction**, locate the **Electrode Kinetics** section.
- 3 In the  $i_{0,ref}(T)$  text field, type i0\_o2\_ref.
- 4 In the  $\alpha_a$  text field, type alpha\_a\_o2.
- 5 Locate the **Active Specific Surface Area** section. In the  $a_v$  text field, type Av.

#### *O2 Gas Flow Channel I*

- 1 In the **Physics** toolbar, click  **Domains** and choose **O2 Gas Flow Channel**.
- 2 In the **Settings** window for **O2 Gas Flow Channel**, locate the **Domain Selection** section.
- 3 From the **Selection** list, choose **O2 Flow Channel**.

#### *Electrolyte Phase I*

Now go back and edit the default phase domain nodes. Also set up the boundary conditions and initial values.

- 1 In the **Model Builder** window, click **Electrolyte Phase I**.
- 2 In the **Settings** window for **Electrolyte Phase**, locate the **Electrolyte Charge Transport** section.
- 3 From the  $\sigma_1$  list, choose **User defined**. In the associated text field, type sigma\_1.

#### *Electronic Conducting Phase I*

In the **Model Builder** window, click **Electronic Conducting Phase I**.

#### *Electric Ground I*

- 1 In the **Physics** toolbar, click  **Attributes** and choose **Electric Ground**.
- 2 In the **Settings** window for **Electric Ground**, locate the **Boundary Selection** section.
- 3 From the **Selection** list, choose **H2 Current Collector**.

#### *Electronic Conducting Phase I*

In the **Model Builder** window, click **Electronic Conducting Phase I**.

#### *Electric Potential I*

- 1 In the **Physics** toolbar, click  **Attributes** and choose **Electric Potential**.
- 2 In the **Settings** window for **Electric Potential**, locate the **Boundary Selection** section.

- 3 From the **Selection** list, choose **O2 Current Collector**.
- 4 Locate the **Electric Potential** section. In the  $\phi_{s,bnd}$  text field, type `E_cell`.  
The `E_cell` parameter will be used by the **Auxiliary sweep** in the **Study** in order to solve for a range of potentials.

#### *O2 Gas Phase 1*

In the **Model Builder** window, under **Component 1 (comp1) > Hydrogen Fuel Cell (fc)** click **O2 Gas Phase 1**.

#### *O2 Inlet 1*

- 1 In the **Physics** toolbar, click  **Attributes** and choose **O2 Inlet**.
- 2 In the **Settings** window for **O2 Inlet**, locate the **Boundary Selection** section.
- 3 From the **Selection** list, choose **Inlets, O2 side**.
- 4 Locate the **Inlet Flow Type** section. From the **Inlet flow type** list, choose **Mixture composition constraint**.

#### *O2 Gas Phase 1*

In the **Model Builder** window, click **O2 Gas Phase 1**.

#### *O2 Outlet 1*

- 1 In the **Physics** toolbar, click  **Attributes** and choose **O2 Outlet**.
- 2 In the **Settings** window for **O2 Outlet**, locate the **Boundary Selection** section.
- 3 From the **Selection** list, choose **Outlets, O2 side**.

#### *Initial Values 1*

- 1 In the **Model Builder** window, click **Initial Values 1**.
- 2 In the **Settings** window for **Initial Values**, locate the **Initial Composition** section.
- 3 From the **Mixture specification** list, choose **Humidified air**.
- 4 In the  $T_{hum}$  text field, type `T_hum`.  
The fuel cell settings are now complete.

### **FREE AND POROUS MEDIA FLOW, BRINKMAN (FP)**

Next, set up the **Free and Porous Media Flow** interface.

- 1 In the **Model Builder** window, under **Component 1 (comp1)** click **Free and Porous Media Flow, Brinkman (fp)**.
- 2 In the **Settings** window for **Free and Porous Media Flow, Brinkman**, locate the **Domain Selection** section.

- 3 From the **Selection** list, choose **O2 Flow Domains**.
- 4 Locate the **Physical Model** section. From the **Compressibility** list, choose **Weakly compressible flow**.

The weakly compressible option is suitable when density changes due to pressure gradients are expected to be relatively small.

#### *Porous Medium 1*

- 1 In the **Physics** toolbar, click  **Domains** and choose **Porous Medium**.
- 2 In the **Settings** window for **Porous Medium**, locate the **Domain Selection** section.
- 3 From the **Selection** list, choose **O2 GDL**.

#### *Porous Matrix 1*

- 1 In the **Model Builder** window, click **Porous Matrix 1**.
- 2 In the **Settings** window for **Porous Matrix**, locate the **Matrix Properties** section.
- 3 From the  $\epsilon_p$  list, choose **User defined**. In the associated text field, type `eps_gdl`.
- 4 From the  $\kappa$  list, choose **User defined**. In the associated text field, type `kappa_gdl`.

#### *Inlet 1*

- 1 In the **Physics** toolbar, click  **Boundaries** and choose **Inlet**.
- 2 In the **Settings** window for **Inlet**, locate the **Boundary Selection** section.
- 3 From the **Selection** list, choose **Inlets, O2 side**.
- 4 Locate the **Boundary Condition** section. From the list, choose **Fully developed flow**.
- 5 Clear the **Apply condition on each disjoint selection separately** checkbox.
- 6 Locate the **Fully Developed Flow** section. In the  $U_{av}$  text field, type `U_in`.

#### *Outlet 1*

- 1 In the **Physics** toolbar, click  **Boundaries** and choose **Outlet**.
- 2 In the **Settings** window for **Outlet**, locate the **Boundary Selection** section.
- 3 From the **Selection** list, choose **Outlets, O2 side**.

#### *Wall 2*

- 1 In the **Physics** toolbar, click  **Boundaries** and choose **Wall**.
- 2 In the **Settings** window for **Wall**, locate the **Boundary Selection** section.
- 3 From the **Selection** list, choose **Slip Walls**.

- 4 Locate the **Boundary Condition** section. From the **Wall condition** list, choose **Slip**.  
Setting the external walls of the porous domain to slip conditions improves the convergence for this model.

## GLOBAL DEFINITIONS

Finalize the physics settings by setting the temperature on the **Default Model Inputs** node. This setting will be used by all physics.

### *Default Model Inputs*

- 1 In the **Model Builder** window, under **Global Definitions** click **Default Model Inputs**.
- 2 In the **Settings** window for **Default Model Inputs**, locate the **Browse Model Inputs** section.
- 3 In the tree, select **General > Temperature (K) - minput.T**.
- 4 Find the **Expression for remaining selection** subsection. In the **Temperature** text field, type T.

## MESH 1

A model geometry of this complexity benefits from manual meshing. The manually created mesh will improve convergence and reduce computational time.

- 1 In the **Model Builder** window, under **Component 1 (comp1)** click **Mesh 1**.
- 2 In the **Settings** window for **Mesh**, locate the **Physics-Controlled Mesh** section.
- 3 From the **Element size** list, choose **Finer**.

### *Mapped 1*

The straight parts of the channels are suitable for sweeping. Start by creating mapped meshes on the start and end faces.

- 1 In the **Mesh** toolbar, click  **More Generators** and choose **Mapped**.
- 2 In the **Settings** window for **Mapped**, locate the **Boundary Selection** section.
- 3 From the **Selection** list, choose **Channel Mesh Sweep Faces**.

### *Distribution 1*

- 1 Right-click **Mapped 1** and choose **Distribution**.
- 2 In the **Settings** window for **Distribution**, locate the **Edge Selection** section.
- 3 From the **Selection** list, choose **All edges**.
- 4 Locate the **Distribution** section. In the **Number of elements** text field, type 4.

### *Swept 1*

- 1 In the **Mesh** toolbar, click  **Swept**.

- 2 In the **Settings** window for **Swept**, locate the **Domain Selection** section.
- 3 From the **Geometric entity level** list, choose **Domain**.
- 4 From the **Selection** list, choose **Channel Sweep Mesh Domains**.

#### Size 1

- 1 Right-click **Swept 1** and choose **Size**.
- 2 In the **Settings** window for **Size**, locate the **Element Size** section.
- 3 Click the **Custom** button.
- 4 Locate the **Element Size Parameters** section.
- 5 Select the **Maximum element size** checkbox. In the associated text field, type  $W_{ch}/1.1$ .
- 6 Click  **Build Selected**.

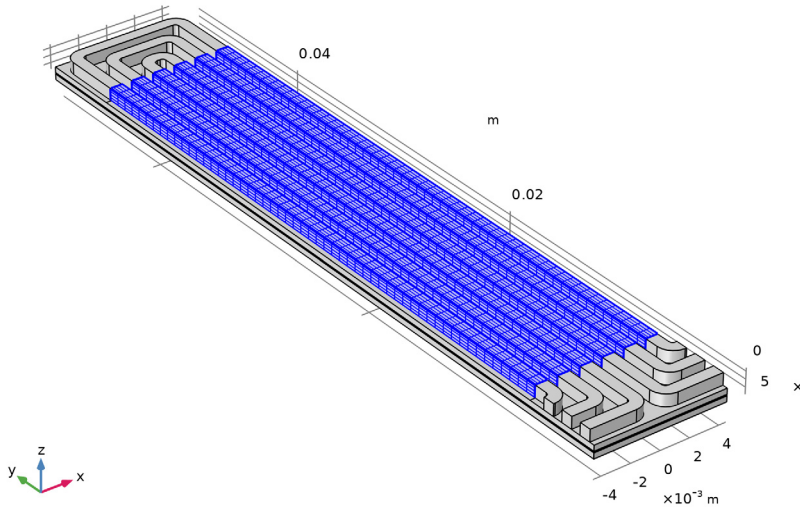

#### Free Tetrahedral 1

Use a free tetrahedral mesh for the curved parts of the flow channels.

- 1 In the **Mesh** toolbar, click  **Free Tetrahedral**.
- 2 In the **Settings** window for **Free Tetrahedral**, locate the **Domain Selection** section.
- 3 From the **Geometric entity level** list, choose **Domain**.
- 4 From the **Selection** list, choose **Channel Tet Mesh Domains**.

### Size 1

- 1 Right-click **Free Tetrahedral 1** and choose **Size**.
- 2 In the **Settings** window for **Size**, locate the **Element Size** section.
- 3 Click the **Custom** button.
- 4 Locate the **Element Size Parameters** section.
- 5 Select the **Maximum element size** checkbox. In the associated text field, type  $W_{ch}/2.1$ .
- 6 Click  **Build Selected**.

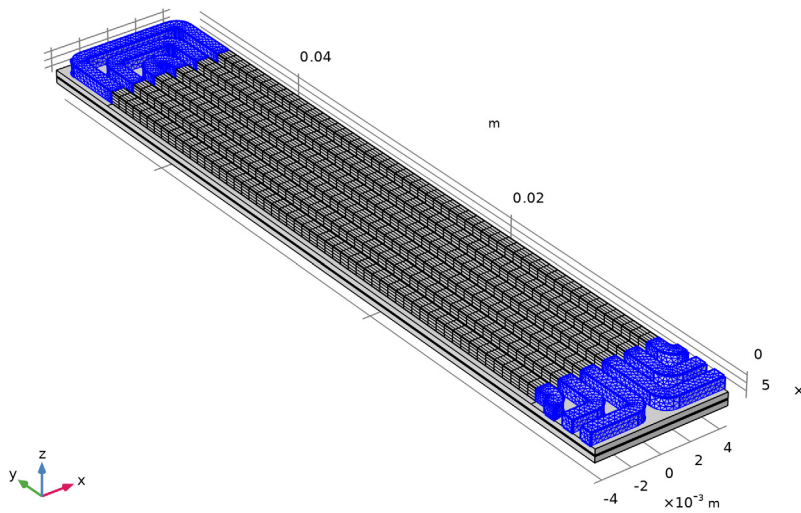

### Boundary Layers 1

Now add boundary layers inside the channels. The boundary layers will resolve the gradients in velocity close to the channel walls.

- 1 In the **Mesh** toolbar, click  **Boundary Layers**.
- 2 In the **Settings** window for **Boundary Layers**, locate the **Geometric Entity Selection** section.
- 3 From the **Geometric entity level** list, choose **Domain**.
- 4 From the **Selection** list, choose **Channels**.

### Boundary Layer Properties

- 1 In the **Model Builder** window, click **Boundary Layer Properties**.

- 2 In the **Settings** window for **Boundary Layer Properties**, locate the **Boundary Selection** section.
- 3 From the **Selection** list, choose **Boundary Layer Walls**.
- 4 Locate the **Layers** section. In the **Number of layers** text field, type 2.
- 5 In the **Stretching factor** text field, type 1.5.
- 6 From the **Thickness specification** list, choose **First layer**.
- 7 In the **Thickness** text field, type  $W_{ch}/10$ .
- 8 Click  **Build Selected**.

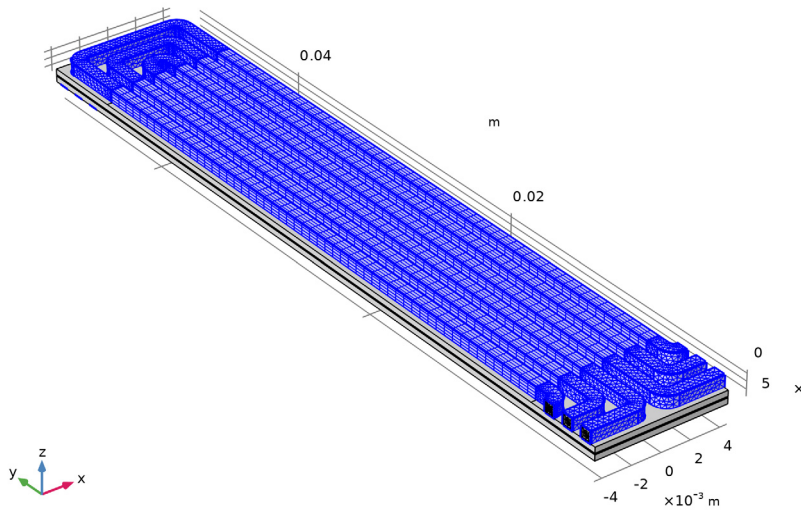

At this point you might want to zoom in the graphics window and inspect the inlet and outlets of the channels to see the created boundary layers.

Now continue to build a surface mesh for the upper GDL boundary. The mesh will then be swept in the through-plane direction for the remaining domains of the oxygen side of the assembly geometry.

- 9 Click the  **Go to XY View** button in the **Graphics** toolbar.

*Mapped 2*

- 1 In the **Mesh** toolbar, click  **More Generators** and choose **Mapped**.
- 2 In the **Settings** window for **Mapped**, locate the **Boundary Selection** section.

3 From the **Selection** list, choose **O2 Current Collector Mapped Mesh Boundaries**.

4 Click  **Build Selected**.

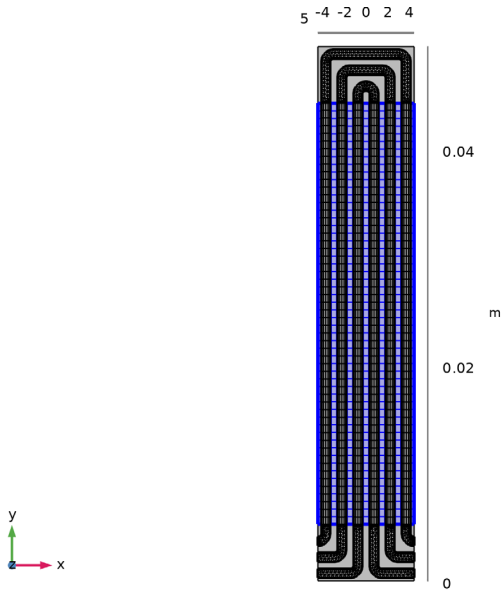

### *Free Triangular 1*

1 In the **Mesh** toolbar, click  **More Generators** and choose **Free Triangular**.

2 In the **Settings** window for **Free Triangular**, locate the **Boundary Selection** section.

3 From the **Selection** list, choose **O2 Current Collector Triangular Mesh Boundaries**.

4 Click  **Build Selected**.

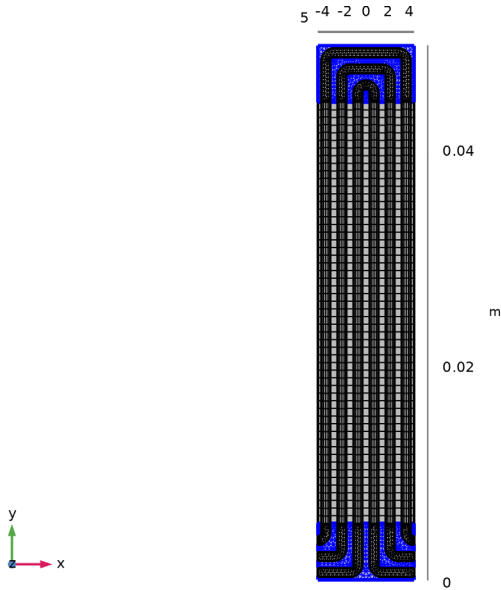

### *Boundary Layers 2*

Add a boundary layer also to the surface mesh. This boundary layer will resolve gradients in the GDL close to the channels below the ribs of the flow field plate.

- 1 In the **Mesh** toolbar, click  **Boundary Layers**.
- 2 In the **Settings** window for **Boundary Layers**, locate the **Geometric Entity Selection** section.
- 3 From the **Geometric entity level** list, choose **Boundary**.
- 4 From the **Selection** list, choose **O2 Current Collector**.

### *Boundary Layer Properties*

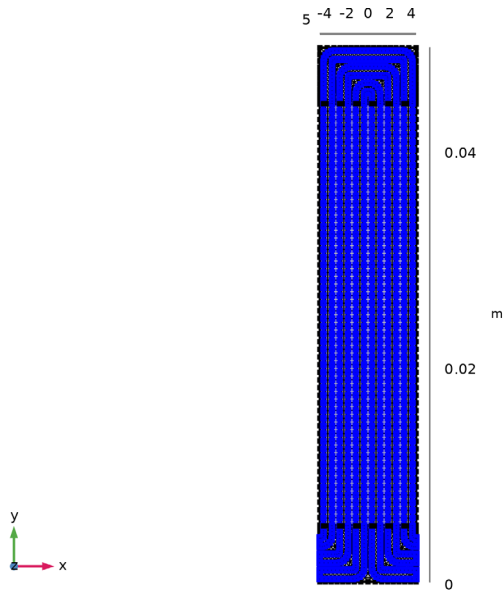

- 1 In the **Model Builder** window, click **Boundary Layer Properties**.
- 2 In the **Settings** window for **Boundary Layer Properties**, locate the **Edge Selection** section.
- 3 From the **Selection** list, choose **Channels**.
- 4 Locate the **Layers** section. In the **Number of layers** text field, type 2.
- 5 From the **Thickness specification** list, choose **First layer**.

6 In the **Thickness** text field, type  $W_{rib}/10$ .



At this point you might want to zoom in the graphics window and inspect the boundary layer at the top of the GDL along the channels.

Now use a triangular mesh for the lowermost boundary of the hydrogen side of the assembly geometry.

7 In the **Graphics** window toolbar, click  next to  **Go to Default View**, then choose **Go to YX View**.

#### *Free Triangular 2*

- 1 In the **Mesh** toolbar, click  **More Generators** and choose **Free Triangular**.
- 2 In the **Settings** window for **Free Triangular**, locate the **Boundary Selection** section.
- 3 From the **Selection** list, choose **Lower GDL Boundary**.

#### *Size 1*

- 1 Right-click **Free Triangular 2** and choose **Size**.
- 2 In the **Settings** window for **Size**, locate the **Element Size** section.
- 3 Click the **Custom** button.
- 4 Locate the **Element Size Parameters** section.
- 5 Select the **Maximum element size** checkbox. In the associated text field, type  $W_{rib}/1.2$ .

6 Click  **Build Selected**.

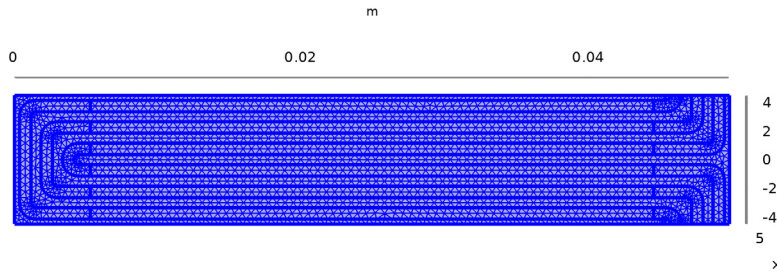

Finally, sweep the remaining domains of the geometry. Specify the number of sweep elements in each domain using separate distribution nodes.

7 Click the  **Go to Default View** button in the **Graphics** toolbar.

*Swept 2*

In the **Mesh** toolbar, click  **Swept**.

*Distribution 1*

- 1 Right-click **Swept 2** and choose **Distribution**.
- 2 In the **Settings** window for **Distribution**, locate the **Domain Selection** section.
- 3 From the **Selection** list, choose **O2 GDL**.
- 4 Locate the **Distribution** section. In the **Number of elements** text field, type 8.

*Distribution 2*

- 1 In the **Model Builder** window, right-click **Swept 2** and choose **Distribution**.
- 2 In the **Settings** window for **Distribution**, locate the **Domain Selection** section.
- 3 From the **Selection** list, choose **Membrane**.
- 4 Locate the **Distribution** section. In the **Number of elements** text field, type 1.

### Distribution 3

- 1 Right-click **Swept 2** and choose **Distribution**.
- 2 In the **Settings** window for **Distribution**, locate the **Domain Selection** section.
- 3 From the **Selection** list, choose **H2 GDL**.
- 4 Locate the **Distribution** section. In the **Number of elements** text field, type 3.
- 5 Click  **Build Selected**.

The final mesh should now look as follows:

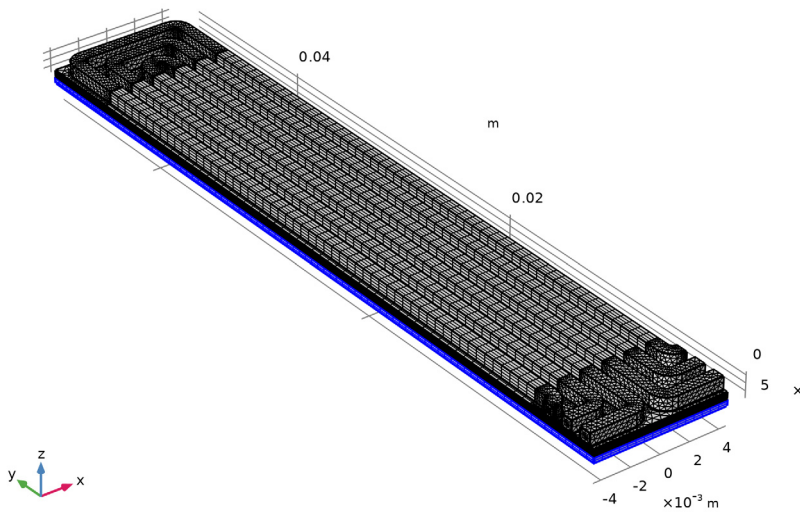

### MESH 1

In the **Model Builder** window, collapse the **Component 1 (comp1) > Mesh 1** node.

### STUDY 1



The model is now ready for solving. Use a sequenced study, solving for the potentials first, then the fluid flow, and finally the fully coupled model.

#### Step 2: Stationary

- 1 In the **Model Builder** window, under **Study 1** click **Step 2: Stationary**.
- 2 In the **Settings** window for **Stationary**, locate the **Physics and Variables Selection** section.

- 3 In the **Solve for** column of the table, under **Component 1 (comp1)**, clear the checkbox for **Hydrogen Fuel Cell (fc)**.

*Step 3: Stationary 2*

- 1 In the **Study** toolbar, click  **Stationary**.
- 2 In the **Settings** window for **Stationary**, click to expand the **Study Extensions** section.  
Use an auxiliary sweep to solve for several different cell potentials.
- 3 Select the **Auxiliary sweep** checkbox.
- 4 Click  **Add**.
- 5 In the table, enter the following settings:

Parameter name	Parameter value list	Parameter unit
E_cell (Cell voltage (varied in auxiliary sweep))	0.9 0.7 0.5	V

- 6 In the **Study** toolbar, click  **Compute**.

## RESULTS

A number of plots were created by default. Inspect the oxygen levels for different cell potentials.

*Mole Fraction, O2, Surface (fc)*

- 1 In the **Model Builder** window, under **Results** click **Mole Fraction, O2, Surface (fc)**.
- 2 In the **Settings** window for **3D Plot Group**, locate the **Data** section.
- 3 From the **Parameter value (E\_cell (V))** list, choose **0.7**.
- 4 In the **Mole Fraction, O2, Surface (fc)** toolbar, click  **Plot**.

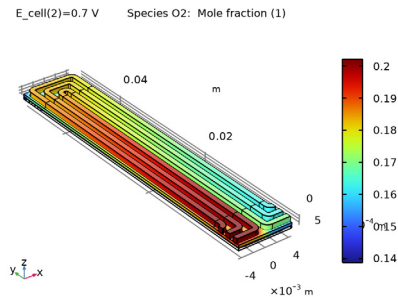

- 5 From the **Parameter value (E\_cell (V))** list, choose **0.5**.

6 In the **Mole Fraction, O<sub>2</sub>, Surface (fc)** toolbar, click  **Plot**.

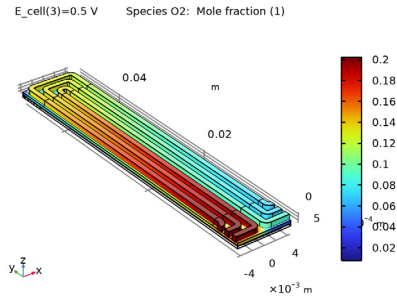

### Channel Velocity

Modify the default plot for velocity to make a plot of the channel velocities as follows:

- 1 In the **Model Builder** window, under **Results** click **Velocity (fp)**.
- 2 In the **Settings** window for **3D Plot Group**, type Channel Velocity in the **Label** text field.

### Multislice 1

- 1 In the **Model Builder** window, expand the **Channel Velocity** node, then click **Multislice 1**.
- 2 In the **Settings** window for **Multislice**, locate the **Multipane Data** section.
- 3 Find the **x-planes** subsection. In the **Planes** text field, type 0.
- 4 Find the **y-planes** subsection. In the **Planes** text field, type 0.
- 5 Find the **z-planes** subsection. From the **Entry method** list, choose **Coordinates**.
- 6 In the **Coordinates** text field, type  $H_{\text{mem}}/2 + H_{\text{gd1}} + H_{\text{ch}}/2$ .
- 7 In the **Channel Velocity** toolbar, click  **Plot**.

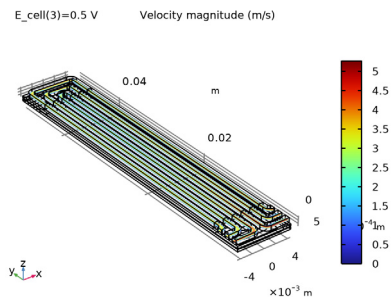

### Channel Velocity

Duplicate this plot to make a plot of the velocities in the GDL as follows:

### *GDL Velocity*

- 1 In the **Model Builder** window, right-click **Channel Velocity** and choose **Duplicate**.
- 2 In the **Settings** window for **3D Plot Group**, type GDL Velocity in the **Label** text field.

### *Multislice 1*

- 1 In the **Model Builder** window, expand the **GDL Velocity** node, then click **Multislice 1**.
- 2 In the **Settings** window for **Multislice**, locate the **Multiplane Data** section.
- 3 Find the **z-planes** subsection. In the **Coordinates** text field, type  $H_{mem}/2 + H_{gd1}/2$ .
- 4 In the **GDL Velocity** toolbar, click  **Plot**.

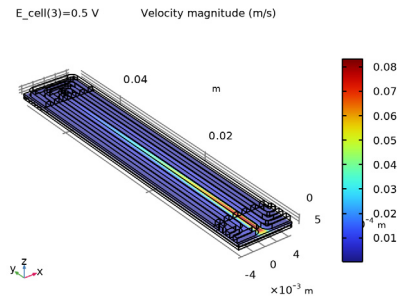

### *O2 GDE Current Density*

Finally, plot the electrolyte current density in the  $z$  direction at the O2 GDE as follows:

- 1 In the **Results** toolbar, click  **3D Plot Group**.
- 2 In the **Settings** window for **3D Plot Group**, type O2 GDE Current Density in the **Label** text field.
- 3 Click to expand the **Selection** section. From the **Geometric entity level** list, choose **Boundary**.
- 4 From the **Selection** list, choose **GDE, O2 Side**.

### *Surface 1*

- 1 Right-click **O2 GDE Current Density** and choose **Surface**.
- 2 In the **Settings** window for **Surface**, click **Replace Expression** in the upper-right corner of the **Expression** section. From the menu, choose **Component 1 (comp1) > Hydrogen Fuel Cell > fc.nll - Normal electrolyte current density - A/m<sup>2</sup>**.
- 3 Locate the **Expression** section. In the **Unit** field, type  $A/cm^2$ .

### *O2 GDE Current Density*

- 1 In the **Model Builder** window, click **O2 GDE Current Density**.

- 2 In the **Settings** window for **3D Plot Group**, locate the **Data** section.
- 3 From the **Parameter value (E\_cell (V))** list, choose **0.7**.
- 4 Locate the **Plot Settings** section. Clear the **Plot dataset edges** checkbox.
- 5 In the **O2 GDE Current Density** toolbar, click  **Plot**.

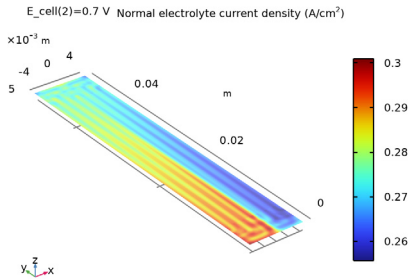

- 6 Locate the **Data** section. From the **Parameter value (E\_cell (V))** list, choose **0.5**.
- 7 In the **O2 GDE Current Density** toolbar, click  **Plot**.

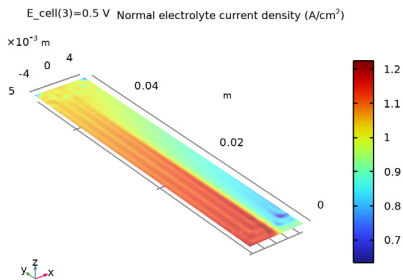

## *Appendix — Geometry Modeling Instructions*



---

From the **File** menu, choose **New**.

### **NEW**

In the **New** window, click  **Model Wizard**.

### **MODEL WIZARD**

- 1 In the **Model Wizard** window, click  **3D**.
- 2 Click  **Done**.

## GLOBAL DEFINITIONS

### Parameters 1

- 1 In the **Model Builder** window, under **Global Definitions** click **Parameters 1**.
- 2 In the **Settings** window for **Parameters**, locate the **Parameters** section.
- 3 Click  **Load from File**.
- 4 Browse to the model's Application Libraries folder and double-click the file `ht_pem_flow_field_geometry_parameters.txt`.

## GEOMETRY 1



### Work Plane 1 (wp1)

- 1 In the **Geometry** toolbar, click  **Work Plane**.
- 2 In the **Settings** window for **Work Plane**, locate the **Plane Definition** section.
- 3 In the **z-coordinate** text field, type  $H_{gd1}+H_{mem}/2$ .



### Work Plane 1 (wp1) > Plane Geometry

In the **Model Builder** window, click **Plane Geometry**.



### Work Plane 1 (wp1) > Rectangle 1 (r1)

- 1 In the **Work Plane** toolbar, click  **Rectangle**.
- 2 In the **Settings** window for **Rectangle**, locate the **Size and Shape** section.
- 3 In the **Width** text field, type  $W_{ch}$ .
- 4 In the **Height** text field, type  $W_{plate}-W_{rib}$ .
- 5 Locate the **Position** section. In the **xw** text field, type  $W_{rib}/2-N_{ch}*W_{ribch}$ .
- 6 In the **yw** text field, type  $W_{rib}/2$ .
- 7 Click  **Build Selected**.
- 8 Click the  **Zoom Extents** button in the **Graphics** toolbar.



### Work Plane 1 (wp1) > Array 1 (arr1)

- 1 In the **Work Plane** toolbar, click  **Transforms** and choose **Array**.
- 2 Select the object **r1** only.
- 3 In the **Settings** window for **Array**, locate the **Size** section.
- 4 In the **xw size** text field, type  $N_{ch}*2$ .
- 5 Locate the **Displacement** section. In the **xw** text field, type  $W_{ribch}$ .
- 6 Click  **Build Selected**.



*Work Plane 1 (wp1) > Rectangle 2 (r2)*

- 1 In the **Work Plane** toolbar, click  **Rectangle**.
- 2 In the **Settings** window for **Rectangle**, locate the **Size and Shape** section.
- 3 In the **Width** text field, type  $2*N\_ch*W\_ribch$ .
- 4 In the **Height** text field, type  $W\_ch$ .
- 5 Locate the **Position** section. In the **xw** text field, type  $-N\_ch*W\_ribch$ .
- 6 In the **yw** text field, type  $W\_rib/2$ .
- 7 Click  **Build Selected**.



*Work Plane 1 (wp1) > Array 2 (arr2)*

- 1 In the **Work Plane** toolbar, click  **Transforms** and choose **Array**.
- 2 Select the object **r2** only.
- 3 In the **Settings** window for **Array**, locate the **Size** section.
- 4 In the **yw size** text field, type  $N\_ch$ .
- 5 Locate the **Displacement** section. In the **yw** text field, type  $W\_ribch$ .
- 6 Click  **Build Selected**.

*Work Plane 1 (wp1) > Mirror 1 (mir1)*

- 1 In the **Work Plane** toolbar, click  **Transforms** and choose **Mirror**.
- 2 Select the objects **arr2(1,1)**, **arr2(1,2)**, and **arr2(1,3)** only.
- 3 In the **Settings** window for **Mirror**, locate the **Input** section.
- 4 Select the **Keep input objects** checkbox.
- 5 Locate the **Point on Line of Reflection** section. In the **yw** text field, type  $W\_plate/2$ .
- 6 Locate the **Normal Vector to Line of Reflection** section. In the **xw** text field, type 0.
- 7 In the **yw** text field, type 1.
- 8 Click  **Build Selected**.

*Work Plane 1 (wp1) > Square 1 (sq1)*

- 1 In the **Work Plane** toolbar, click  **Square**.
- 2 In the **Settings** window for **Square**, locate the **Size** section.
- 3 In the **Side length** text field, type  $\sqrt{2}*W\_ribch*(N\_ch+1)$ .
- 4 Locate the **Rotation Angle** section. In the **Rotation** text field, type 45.
- 5 Click  **Build Selected**.



*Work Plane 1 (wp1) > Square 2 (sq2)*

- 1 In the **Model Builder** window, under **Component 1 (comp1) > Geometry 1 > Work Plane 1 (wp1) > Plane Geometry** right-click **Square 1 (sq1)** and choose **Duplicate**.
- 2 In the **Settings** window for **Square**, locate the **Rotation Angle** section.
- 3 In the **Rotation** text field, type 45+90.
- 4 Click  **Build Selected**.



*Work Plane 1 (wp1) > Square 3 (sq3)*

- 1 Right-click **Component 1 (comp1) > Geometry 1 > Work Plane 1 (wp1) > Plane Geometry > Square 2 (sq2)** and choose **Duplicate**.
- 2 In the **Settings** window for **Square**, locate the **Rotation Angle** section.
- 3 In the **Rotation** text field, type 45-90.
- 4 Click  **Build Selected**.



*Work Plane 1 (wp1) > Copy 1 (copy1)*

- 1 In the **Work Plane** toolbar, click  **Transforms** and choose **Copy**.
- 2 Select the objects **sq1**, **sq2**, and **sq3** only.
- 3 In the **Settings** window for **Copy**, locate the **Displacement** section.
- 4 In the **yw** text field, type  $W\_plate - (+W\_ribch * (N\_ch))$ .
- 5 Click  **Build Selected**.
- 6 Click the  **Zoom Extents** button in the **Graphics** toolbar.

*Work Plane 1 (wp1) > Difference 1 (dif1)*



- 1 In the **Work Plane** toolbar, click  **Booleans and Partitions** and choose **Difference**.
- 2 Select the objects **arr2(1,1)**, **arr2(1,2)**, and **arr2(1,3)** only.
- 3 In the **Settings** window for **Difference**, locate the **Difference** section.
- 4 Click to select the  **Activate Selection** toggle button for **Objects to subtract**.
- 5 Select the object **sq1** only.
- 6 Click  **Build Selected**.

*Work Plane 1 (wp1) > Difference 2 (dif2)*



- 1 In the **Work Plane** toolbar, click  **Booleans and Partitions** and choose **Difference**.
- 2 Select the objects **mir1(1)**, **mir1(2)**, and **mir1(3)** only.
- 3 In the **Settings** window for **Difference**, locate the **Difference** section.
- 4 Click to select the  **Activate Selection** toggle button for **Objects to subtract**.
- 5 Select the objects **copy1(2)** and **copy1(3)** only.

6 Click  **Build Selected**.



*Work Plane 1 (wp1) > Difference 3 (dif3)*

- 1 In the **Work Plane** toolbar, click  **Booleans and Partitions** and choose **Difference**.
- 2 Select the objects **arr1(1,1)**, **arr1(2,1)**, **arr1(3,1)**, **arr1(4,1)**, **arr1(5,1)**, and **arr1(6,1)** only.
- 3 In the **Settings** window for **Difference**, locate the **Difference** section.
- 4 Click to select the  **Activate Selection** toggle button for **Objects to subtract**.
- 5 Select the objects **copy1(1)**, **sq2**, and **sq3** only.
- 6 Click  **Build Selected**.





*Work Plane 1 (wp1) > Union 1 (uni1)*

- 1 In the **Work Plane** toolbar, click  **Booleans and Partitions** and choose **Union**.
- 2 Click in the **Graphics** window and then press Ctrl+A to select all objects.
- 3 In the **Settings** window for **Union**, locate the **Union** section.
- 4 Clear the **Keep interior boundaries** checkbox.
- 5 Click  **Build Selected**.

*Work Plane 1 (wp1) > Fillet 1 (fil1)*

- 1 In the **Work Plane** toolbar, click  **Fillet**.
- 2 Click the  **Zoom Box** button in the **Graphics** toolbar.
- 3 On the object **uni1**, select Points 7, 10, 11, 14, 15, 18, 20, 21, 24, 25, 28, and 29 only.
- 4 In the **Settings** window for **Fillet**, locate the **Radius** section.
- 5 In the **Radius** text field, type r\_ch.
- 6 Click  **Build Selected**.

*Work Plane 1 (wp1) > Fillet 2 (fil2)*

- 1 In the **Work Plane** toolbar, click  **Fillet**.
- 2 On the object **fill**, select Points 10, 16, 22, 26, 32, and 38 only.
- 3 Click the  **Zoom Out** button in the **Graphics** toolbar.
- 4 Click the  **Zoom Out** button in the **Graphics** toolbar.
- 5 Click the  **Zoom Box** button in the **Graphics** toolbar.
- 6 On the object **fill**, select Points 9, 10, 15, 16, 21, 22, 26, 29, 32, 35, 38, and 41 only.
- 7 In the **Settings** window for **Fillet**, locate the **Radius** section.
- 8 In the **Radius** text field, type W\_ch+r\_ch.
- 9 Click  **Build Selected**.

10 Click the  **Zoom Extents** button in the **Graphics** toolbar.



#### *Channels*

- 1 In the **Model Builder** window, right-click **Geometry 1** and choose **Extrude**.
- 2 In the **Settings** window for **Extrude**, type Channels in the **Label** text field.
- 3 Locate the **Distances** section. In the table, enter the following settings:



<b>Distances (m)</b>
H_ch

- 4 Locate the **Selections of Resulting Entities** section. Select the **Resulting objects selection** checkbox.
- 5 From the **Show in physics** list, choose **All levels**.
- 6 Click  **Build Selected**.



#### *Work Plane 2 (wp2)*

- 1 In the **Geometry** toolbar, click  **Work Plane**.
- 2 In the **Settings** window for **Work Plane**, locate the **Plane Definition** section.
- 3 From the **Plane** list, choose **zx-plane**.
- 4 In the **y-coordinate** text field, type  $N\_ch * W\_ribch + W\_ch$ .
- 5 Click  **Build Selected**.



#### *Partition Domains 1 (pard1)*

- 1 In the **Geometry** toolbar, click  **Booleans and Partitions** and choose **Partition Domains**.
- 2 In the **Settings** window for **Partition Domains**, locate the **Partition Domains** section.
- 3 From the **Domains to partition** list, choose **Channels**.
- 4 Click  **Build Selected**.



#### *Work Plane 3 (wp3)*

- 1 In the **Geometry** toolbar, click  **Work Plane**.
- 2 In the **Settings** window for **Work Plane**, locate the **Plane Definition** section.
- 3 From the **Plane** list, choose **zx-plane**.
- 4 In the **y-coordinate** text field, type  $W\_plate - N\_ch * W\_ribch - W\_ch$ .
- 5 Click  **Build Selected**.

### *Partition Domains 2 (pard2)*

- 1 In the **Geometry** toolbar, click  **Booleans and Partitions** and choose **Partition Domains**.
- 2 In the **Settings** window for **Partition Domains**, locate the **Partition Domains** section.
- 3 From the **Domains to partition** list, choose **Channels**.
- 4 Click  **Build Selected**.

### *Channel Sweep Mesh Domains*

- 1 In the **Geometry** toolbar, click  **Selections** and choose **Box Selection**.
- 2 In the **Settings** window for **Box Selection**, type Channel Sweep Mesh Domains in the **Label** text field.
- 3 Locate the **Box Limits** section. In the **y minimum** text field, type  $N\_ch * W\_ribch - W\_ch$ .
- 4 In the **y maximum** text field, type  $W\_plate - N\_ch * W\_ribch + W\_ch$ .
- 5 Locate the **Output Entities** section. From the **Include entity if** list, choose **Entity inside box**.
- 6 Click  **Build Selected**.

### *Channel Tet Mesh Domains*

- 1 In the **Geometry** toolbar, click  **Selections** and choose **Difference Selection**.
- 2 In the **Settings** window for **Difference Selection**, type Channel Tet Mesh Domains in the **Label** text field.
- 3 Locate the **Input Entities** section. Click the **+ Add** button for **Selections to add**.
- 4 In the **Add** dialog, select **Channels** in the **Selections to add** list.
- 5 Click **OK**.
- 6 In the **Settings** window for **Difference Selection**, locate the **Input Entities** section.
- 7 Click the **+ Add** button for **Selections to subtract**.
- 8 In the **Add** dialog, select **Channel Sweep Mesh Domains** in the **Selections to subtract** list.
- 9 Click **OK**.

### *GDL*

- 1 In the **Geometry** toolbar, click  **Block**.
- 2 In the **Settings** window for **Block**, type GDL in the **Label** text field.
- 3 Locate the **Size and Shape** section. In the **Width** text field, type  $2 * N\_ch * W\_ribch$ .
- 4 In the **Depth** text field, type  $W\_plate$ .
- 5 In the **Height** text field, type  $H\_gdl$ .

- 6 Locate the **Position** section. In the **x** text field, type `-N_ch*W_ribch`.
- 7 In the **z** text field, type `H_mem/2`.
- 8 Locate the **Selections of Resulting Entities** section. Select the **Resulting objects selection** checkbox.
- 9 Click  **Build Selected**.

#### *Membrane*

- 1 In the **Geometry** toolbar, click  **Extrude**.
- 2 In the **Settings** window for **Extrude**, type *Membrane* in the **Label** text field.
- 3 Locate the **General** section. From the **Extrude from** list, choose **Faces**.
- 4 On the object **blk1**, select **Boundary 1** only.
- 5 From the **Input object handling** list, choose **Keep**.
- 6 Locate the **Distances** section. In the table, enter the following settings:



<b>Distances (m)</b>
<code>H_mem/2</code>

- 7 Locate the **Selections of Resulting Entities** section. Select the **Resulting objects selection** checkbox.
- 8 Click  **Build Selected**.

#### *Union 1 (un1)*

- 1 In the **Geometry** toolbar, click  **Booleans and Partitions** and choose **Union**.
- 2 Click in the **Graphics** window and then press **Ctrl+A** to select all objects.

#### *Rotate 1 (rot1)*



- 1 In the **Geometry** toolbar, click  **Transforms** and choose **Rotate**.
- 2 Select the object **un1** only.
- 3 In the **Settings** window for **Rotate**, locate the **Input** section.
- 4 Select the **Keep input objects** checkbox.
- 5 Locate the **Rotation** section. From the **Axis type** list, choose **x-axis**.
- 6 In the **Angle** text field, type `180`.
- 7 Locate the **Point on Axis of Rotation** section. In the **y** text field, type `W_plate/2`.
- 8 Click  **Build Selected**.

#### *H2 Side Domains*

- 1 In the **Geometry** toolbar, click  **Selections** and choose **Box Selection**.

- 2 In the **Settings** window for **Box Selection**, type H2 Side Domains in the **Label** text field.
- 3 Locate the **Box Limits** section. In the **z maximum** text field, type  $-H_{mem}/4$ .
- 4 Click  **Build Selected**.

#### *H2 Flow Channels*

- 1 In the **Geometry** toolbar, click  **Selections** and choose **Intersection Selection**.
- 2 In the **Settings** window for **Intersection Selection**, type H2 Flow Channels in the **Label** text field.
- 3 Locate the **Input Entities** section. Click  **Add**.
- 4 In the **Add** dialog, in the **Selections to intersect** list, choose **Channels** and **H2 Side Domains**.
- 5 Click **OK**.
- 6 In the **Settings** window for **Intersection Selection**, click  **Build Selected**.

#### *Delete Entities I (del)*



- 1 Right-click **Geometry I** and choose **Delete Entities**.
- 2 In the **Settings** window for **Delete Entities**, locate the **Entities or Objects to Delete** section.
- 3 From the **Geometric entity level** list, choose **Domain**.
- 4 From the **Selection** list, choose **H2 Flow Channels**.
- 5 Click  **Build Selected**.

#### *Upper GDL Boundary*



- 1 In the **Geometry** toolbar, click  **Selections** and choose **Box Selection**.
- 2 In the **Settings** window for **Box Selection**, type Upper GDL Boundary in the **Label** text field.
- 3 Locate the **Geometric Entity Level** section. From the **Level** list, choose **Boundary**.
- 4 Locate the **Box Limits** section. In the **z minimum** text field, type  $H_{gd1}/2+H_{mem}/2$ .
- 5 In the **z maximum** text field, type  $H_{gd1}*3/2+H_{mem}$ .
- 6 Locate the **Output Entities** section. From the **Include entity if** list, choose **Entity inside box**.

#### *O2 Current Collector*



- 1 In the **Geometry** toolbar, click  **Selections** and choose **Difference Selection**.
- 2 In the **Settings** window for **Difference Selection**, type O2 Current Collector in the **Label** text field.
- 3 Locate the **Geometric Entity Level** section. From the **Level** list, choose **Boundary**.

- 4 Locate the **Input Entities** section. Click the  **Add** button for **Selections to add**.
- 5 In the **Add** dialog, select **Upper GDL Boundary** in the **Selections to add** list.
- 6 Click **OK**.
- 7 In the **Settings** window for **Difference Selection**, locate the **Input Entities** section.
- 8 Click the  **Add** button for **Selections to subtract**.
- 9 In the **Add** dialog, select **Channels** in the **Selections to subtract** list.
- 10 Click **OK**.

#### *Partition Faces 1 (parf1)*

- 1 In the **Geometry** toolbar, click  **Booleans and Partitions** and choose **Partition Faces**.
- 2 In the **Settings** window for **Partition Faces**, locate the **Partition Faces** section.
- 3 From the **Faces to partition** list, choose **O2 Current Collector**.
- 4 From the **Partition with** list, choose **Work plane**.
- 5 Click  **Build Selected**.

#### *Partition Faces 2 (parf2)*

- 1 Right-click **Partition Faces 1 (parf1)** and choose **Duplicate**.
- 2 In the **Settings** window for **Partition Faces**, locate the **Partition Faces** section.
- 3 Click to select the  **Activate Selection** toggle button for **Faces to partition**.
- 4 From the **Work plane** list, choose **Work Plane 2 (wp2)**.
- 5 Click  **Build Selected**.

#### *Form Union (fin)*

- 1 In the **Model Builder** window, under **Component 1 (comp1)** > **Geometry 1** click **Form Union (fin)**.
- 2 In the **Settings** window for **Form Union/Assembly**, locate the **Form Union/Assembly** section.
- 3 From the **Action** list, choose **Form an assembly**.
- 4 Click  **Build Selected**.

#### *Inlets, O2 side*

- 1 In the **Geometry** toolbar, click  **Selections** and choose **Box Selection**.
- 2 In the **Settings** window for **Box Selection**, type Inlets, O2 side in the **Label** text field.
- 3 Locate the **Geometric Entity Level** section. From the **Level** list, choose **Boundary**.
- 4 Locate the **Box Limits** section. In the **x maximum** text field, type  $-W_{ribch} \cdot 3 + W_{ch} / 10$ .
- 5 In the **z minimum** text field, type  $H_{mem} / 2 + H_{gd1} / 2$ .

6 Locate the **Output Entities** section. From the **Include entity if** list, choose **Entity inside box**.

7 Click  **Build Selected**.

#### *Outlets, O2 side*

1 Right-click **Inlets, O2 side** and choose **Duplicate**.

2 In the **Settings** window for **Box Selection**, type Outlets, O2 side in the **Label** text field.

3 Locate the **Box Limits** section. In the **x minimum** text field, type  $W\_ribch*3-W\_ch/10$ .

4 In the **x maximum** text field, type Inf.

5 Click  **Build Selected**.

#### *Slip Walls*

1 In the **Geometry** toolbar, click  **Selections** and choose **Difference Selection**.

2 In the **Settings** window for **Difference Selection**, type Slip Walls in the **Label** text field.

3 Locate the **Geometric Entity Level** section. From the **Level** list, choose **Boundary**.

4 Locate the **Input Entities** section. Click the **+ Add** button for **Selections to add**.

5 In the **Add** dialog, select **GDL** in the **Selections to add** list.

6 Click **OK**.

7 In the **Settings** window for **Difference Selection**, locate the **Input Entities** section.

8 Click the **+ Add** button for **Selections to subtract**.

9 In the **Add** dialog, select **Channels** in the **Selections to subtract** list.

10 Click **OK**.

#### *Boundary Layer Walls*

1 In the **Geometry** toolbar, click  **Selections** and choose **Difference Selection**.

2 In the **Settings** window for **Difference Selection**, type Boundary Layer Walls in the **Label** text field.

3 Locate the **Geometric Entity Level** section. From the **Level** list, choose **Boundary**.

4 Locate the **Input Entities** section. Click the **+ Add** button for **Selections to add**.

5 In the **Add** dialog, select **Channels** in the **Selections to add** list.

6 Click **OK**.



7 In the **Settings** window for **Difference Selection**, locate the **Input Entities** section.

8 Click the **+ Add** button for **Selections to subtract**.

9 In the **Add** dialog, in the **Selections to subtract** list, choose **Inlets, O2 side** and **Outlets, O2 side**.

10 Click **OK**.

#### *O2 Side Domains*

- 1 In the **Geometry** toolbar, click  **Selections** and choose **Box Selection**.
- 2 In the **Settings** window for **Box Selection**, type O2 Side Domains in the **Label** text field.
- 3 Locate the **Box Limits** section. In the **z minimum** text field, type  $H_{\text{mem}}/4$ .
- 4 Click  **Build Selected**.

#### *GDE, O2 Side*

- 1 In the **Geometry** toolbar, click  **Selections** and choose **Box Selection**.
- 2 In the **Settings** window for **Box Selection**, type GDE, O2 Side in the **Label** text field.
- 3 Locate the **Box Limits** section. In the **z minimum** text field, type  $H_{\text{mem}}/4$ .
- 4 In the **z maximum** text field, type  $H_{\text{mem}}/2 + H_{\text{gd1}}/2$ .
- 5 Locate the **Output Entities** section. From the **Include entity if** list, choose **Entity inside box**.
- 6 Locate the **Geometric Entity Level** section. From the **Level** list, choose **Boundary**.

#### *GDE, H2 Side*



- 1 Right-click **GDE, O2 Side** and choose **Duplicate**.
- 2 In the **Settings** window for **Box Selection**, type GDE, H2 Side in the **Label** text field.
- 3 Locate the **Box Limits** section. In the **z minimum** text field, type  $-H_{\text{mem}}/2 - H_{\text{gd1}}/2$ .
- 4 In the **z maximum** text field, type  $-H_{\text{mem}}/4$ .
- 5 Click  **Build Selected**.

#### *O2 Flow Channel*

- 1 In the **Geometry** toolbar, click  **Selections** and choose **Intersection Selection**.
- 2 In the **Settings** window for **Intersection Selection**, type O2 Flow Channel in the **Label** text field.
- 3 Locate the **Input Entities** section. Click **+ Add**.
- 4 In the **Add** dialog, in the **Selections to intersect** list, choose **Channels** and **O2 Side Domains**.
- 5 Click **OK**.

#### *H2 GDL*



- 1 In the **Geometry** toolbar, click  **Selections** and choose **Intersection Selection**.
- 2 In the **Settings** window for **Intersection Selection**, type H2 GDL in the **Label** text field.
- 3 Locate the **Input Entities** section. Click **+ Add**.

- 4 In the **Add** dialog, in the **Selections to intersect** list, choose **Channels** and **H2 Side Domains**.
- 5 Click **OK**.
- 6 In the **Settings** window for **Intersection Selection**, locate the **Input Entities** section.
- 7 In the **Selections to intersect** list box, select **Channels**.
- 8 Click  **Delete**.
- 9 Click  **Add**.
- 10 In the **Add** dialog, select **GDL** in the **Selections to intersect** list.
- 11 Click **OK**.



#### *H2 GDL (intsel3)*

- 1 In the **Model Builder** window, click **H2 GDL**.
- 2 In the **Settings** window for **Intersection Selection**, click  **Build Selected**.

#### *O2 GDL*

- 1 Right-click **H2 GDL** and choose **Duplicate**.
- 2 In the **Settings** window for **Intersection Selection**, type O2 GDL in the **Label** text field.
- 3 Locate the **Input Entities** section. In the **Selections to intersect** list box, select **H2 Side Domains**.
- 4 Click  **Delete**.
- 5 Click  **Add**.
- 6 In the **Add** dialog, select **O2 Side Domains** in the **Selections to intersect** list.
- 7 Click **OK**.
- 8 In the **Settings** window for **Intersection Selection**, click  **Build Selected**.

#### *O2 Flow Domains*

- 1 In the **Geometry** toolbar, click  **Selections** and choose **Union Selection**.
- 2 In the **Settings** window for **Union Selection**, type O2 Flow Domains in the **Label** text field.
- 3 Locate the **Input Entities** section. Click  **Add**.
- 4 In the **Add** dialog, in the **Selections to add** list, choose **O2 Flow Channel** and **O2 GDL**.
- 5 Click **OK**.

#### *Lower GDL Boundary*

- 1 In the **Geometry** toolbar, click  **Selections** and choose **Box Selection**.
- 2 In the **Settings** window for **Box Selection**, type Lower GDL Boundary in the **Label** text field.

- 3 Locate the **Geometric Entity Level** section. From the **Level** list, choose **Boundary**.
- 4 Locate the **Box Limits** section. In the **z minimum** text field, type  $-H_{gd1} * 3/2 - H_{mem}$ .
- 5 In the **z maximum** text field, type  $-H_{gd1}/2 - H_{mem}/2$ .
- 6 Locate the **Output Entities** section. From the **Include entity if** list, choose **Entity inside box**.
- 7 Click  **Build Selected**.

#### *Work Plane 1 (wp1)*

In the **Model Builder** window, collapse the **Component 1 (comp1) > Geometry 1 > Work Plane 1 (wp1)** node.

#### *H2 Current Collector*



- 1 In the **Geometry** toolbar, click  **Selections** and choose **Difference Selection**.
- 2 In the **Settings** window for **Difference Selection**, type H2 Current Collector in the **Label** text field.
- 3 Locate the **Geometric Entity Level** section. From the **Level** list, choose **Boundary**.
- 4 Locate the **Input Entities** section. Click the **+ Add** button for **Selections to add**.
- 5 In the **Add** dialog, select **Lower GDL Boundary** in the **Selections to add** list.
- 6 Click **OK**.
- 7 In the **Settings** window for **Difference Selection**, locate the **Input Entities** section.
- 8 Click the **+ Add** button for **Selections to subtract**.
- 9 In the **Add** dialog, select **Channels** in the **Selections to subtract** list.
- 10 Click **OK**.

#### *Channel Sweep Mesh Boundaries*



- 1 In the **Geometry** toolbar, click  **Selections** and choose **Adjacent Selection**.
- 2 In the **Settings** window for **Adjacent Selection**, type Channel Sweep Mesh Boundaries in the **Label** text field.
- 3 Locate the **Input Entities** section. From the **Geometric entity level** list, choose **Domain**.
- 4 Click **+ Add**.
- 5 In the **Add** dialog, select **Channel Sweep Mesh Domains** in the **Input selections** list.
- 6 Click **OK**.

#### *Channel Tet Mesh Boundaries*



- 1 Right-click **Channel Sweep Mesh Boundaries** and choose **Duplicate**.

- 2 In the **Settings** window for **Adjacent Selection**, type Channel Tet Mesh Boundaries in the **Label** text field.
- 3 Locate the **Input Entities** section. Click **Build Preceding State**.
- 4 In the **Input selections** list box, select **Channel Sweep Mesh Domains**.
- 5 Click  **Delete**.
- 6 Click  **Add**.
- 7 In the **Add** dialog, select **Channel Tet Mesh Domains** in the **Input selections** list.
- 8 Click **OK**.
- 9 In the **Settings** window for **Adjacent Selection**, click  **Build Selected**.

#### *Channel Mesh Sweep Faces*

- 1 In the **Geometry** toolbar, click  **Selections** and choose **Intersection Selection**.
- 2 In the **Settings** window for **Intersection Selection**, locate the **Geometric Entity Level** section.
- 3 From the **Level** list, choose **Boundary**.
- 4 In the **Label** text field, type Channel Mesh Sweep Faces.
- 5 Locate the **Input Entities** section. Click  **Add**.
- 6 In the **Add** dialog, in the **Selections to intersect** list, choose **Channel Sweep Mesh Boundaries** and **Channel Tet Mesh Boundaries**.
- 7 Click **OK**.

#### *GDL Upper Boundary Mesh Sweep Area*

- 1 In the **Geometry** toolbar, click  **Selections** and choose **Box Selection**.
- 2 In the **Settings** window for **Box Selection**, type GDL Upper Boundary Mesh Sweep Area in the **Label** text field.
- 3 Locate the **Geometric Entity Level** section. From the **Level** list, choose **Boundary**.
- 4 Locate the **Box Limits** section. In the **y minimum** text field, type  $N_{ch} * W_{ribch} + W_{ch} - W_{ch} / 2$ .
- 5 In the **y maximum** text field, type  $W_{plate} - N_{ch} * W_{ribch} - W_{ch} + W_{ch} / 2$ .
- 6 In the **z minimum** text field, type  $H_{gd1} / 2 + H_{mem} / 2$ .
- 7 In the **z maximum** text field, type  $H_{gd1} * 3 / 2 + H_{mem} / 2$ .
- 8 Locate the **Output Entities** section. From the **Include entity if** list, choose **Entity inside box**.
- 9 Click  **Build Selected**.

### *O2 Current Collector Mapped Mesh Boundaries*

- 1 In the **Geometry** toolbar, click  **Selections** and choose **Intersection Selection**.
- 2 In the **Settings** window for **Intersection Selection**, type **O2 Current Collector Mapped Mesh Boundaries** in the **Label** text field.
- 3 Locate the **Geometric Entity Level** section. From the **Level** list, choose **Boundary**.
- 4 Locate the **Input Entities** section. Click **+ Add**.
- 5 In the **Add** dialog, in the **Selections to intersect** list, choose **O2 Current Collector** and **GDL Upper Boundary Mesh Sweep Area**.
- 6 Click **OK**.

### *O2 Current Collector Triangular Mesh Boundaries*

- 1 In the **Geometry** toolbar, click  **Selections** and choose **Difference Selection**.
- 2 In the **Settings** window for **Difference Selection**, type **O2 Current Collector Triangular Mesh Boundaries** in the **Label** text field.
- 3 Locate the **Geometric Entity Level** section. From the **Level** list, choose **Boundary**.
- 4 Locate the **Input Entities** section. Click the **+ Add** button for **Selections to add**.
- 5 In the **Add** dialog, select **O2 Current Collector** in the **Selections to add** list.
- 6 Click **OK**.
- 7 In the **Settings** window for **Difference Selection**, locate the **Input Entities** section.
- 8 Click the **+ Add** button for **Selections to subtract**.
- 9 In the **Add** dialog, select **O2 Current Collector Mapped Mesh Boundaries** in the **Selections to subtract** list.
- 10 Click **OK**.