



Model created in COMSOL Multiphysics 6.4

Fatigue Analysis of a Nonproportionally Loaded Shaft with a Fillet

Introduction

This benchmark model is based on the example found in section 5.4.3 of [Ref. 1](#). It shows how to perform a high-cycle fatigue analysis for nonproportional loading using critical plane methods.

Model Definition

The geometry is a circular shaft with two different diameters, 10 mm and 16 mm. At the transition between the two diameters there is a fillet with a radius of 2 mm.

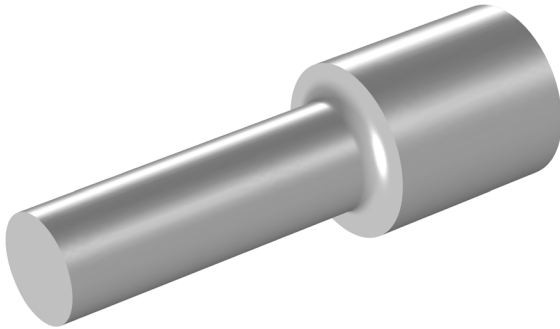

Figure 1: The notched shaft.

Two time-dependent loads are applied at the small end of the shaft: a transverse force and a twisting moment. The force varies between 0 and 1.94 kN and the torque varies between -28.7 and $+28.7$ Nm. [Figure 2](#) shows the history of one loading cycle.

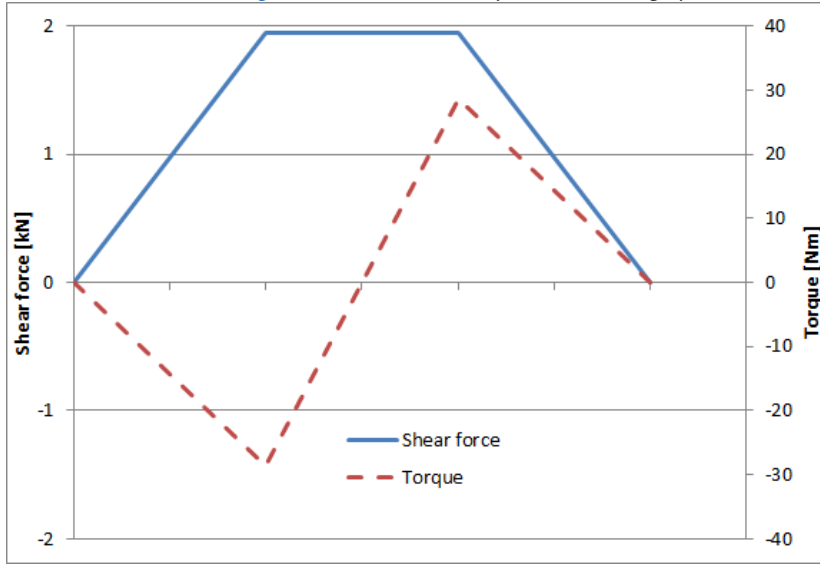

Figure 2: Load history.

The big end of the shaft is fixed. The material is Elastic with $E = 100$ GPa and $\nu = 0$.

In [Ref. 1](#) it is stated that the fatigue limit for completely reversed axial tension is 700 MPa, while the fatigue limit for pure tension is 560 MPa. These values are the stress amplitudes. In uniaxial loading, the Findley criterion can be written as

$$\sqrt{(\sigma_a)^2 + (k \cdot \sigma_{\max})^2} + k \cdot \sigma_{\max} = 2f$$

where σ_a is the stress amplitude and σ_{\max} is the maximum stress experienced in a fatigue cycle. This means that you have to solve the simultaneous equations

$$\begin{aligned} \sqrt{700^2 + (k \cdot 700)^2} + k \cdot 700 &= 2f \\ \sqrt{560^2 + (k \cdot 1120)^2} + k \cdot 1120 &= 2f \end{aligned}$$

to get the Findley parameters f and k . The result is $f = 440$ MPa and $k = 0.23$.

The Mataka criterion is similar to the Findley criterion, with the difference that the critical plane is defined solely by the maximum shear stress. For a uniaxial case, the Mataka expression is

$$\frac{\sigma_a}{2} \left(1 + \frac{k \sigma_{\max}}{\sigma_a} \right) = f$$

which gives the corresponding system of equations as

$$\begin{aligned} 350 \cdot (1 + k) &= f \\ 280 \cdot (1 + 2k) &= f \end{aligned}$$

The solution is $f = 467$ MPa and $k = 0.33$ as parameters for the Mataka case.

The Dang Van criterion utilizes the stress history on a plane that has undergone an elastic shakedown. It evaluates fatigue using the expression

$$\tau_{\max} + a \sigma_H = b$$

where τ_{\max} is the maximum shear stress and σ_H is the hydrostatic stress, while a and b are material parameters. For the fatigue tests above, the Dang Van relation transforms to

$$\frac{\sigma_a}{2} + a \frac{\sigma_{\max}}{3} = b$$

where σ_a is the stress amplitude and σ_{\max} is the maximum stress. The material constants are obtained from the following set of equations

$$\begin{aligned} 350 + a \cdot 233 &= b \\ 280 + a \cdot 373 &= b \end{aligned}$$

The material parameters of the Dang Van model are $b = 467$ MPa and $a = 0.5$.

Results and Discussion

[Figure 3](#) and [Figure 4](#) show stress distributions from the two basic load cases. The location for the maximum equivalent stress is at the surface of the fillet, at a radius slightly larger than the minimum radius of the shaft.

In [Figure 5](#) the equivalent stress from the combined load case with transverse force and positive torque is shown. It is symmetric with respect to the XY -plane and is identical also for the case when the torque is reversed.

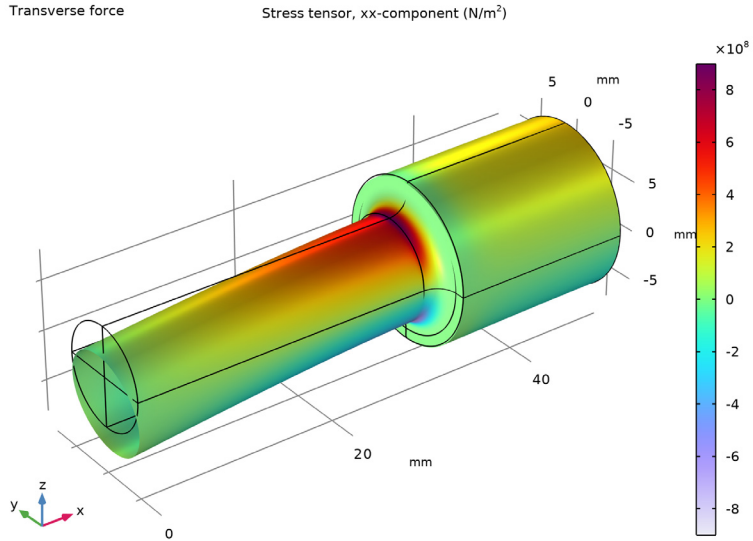

Figure 3: Axial stress from transverse force.

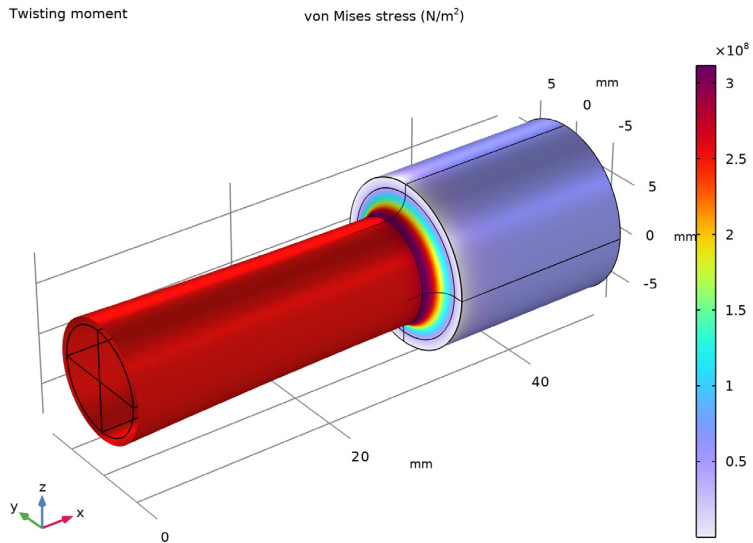

Figure 4: Equivalent stress from torque.

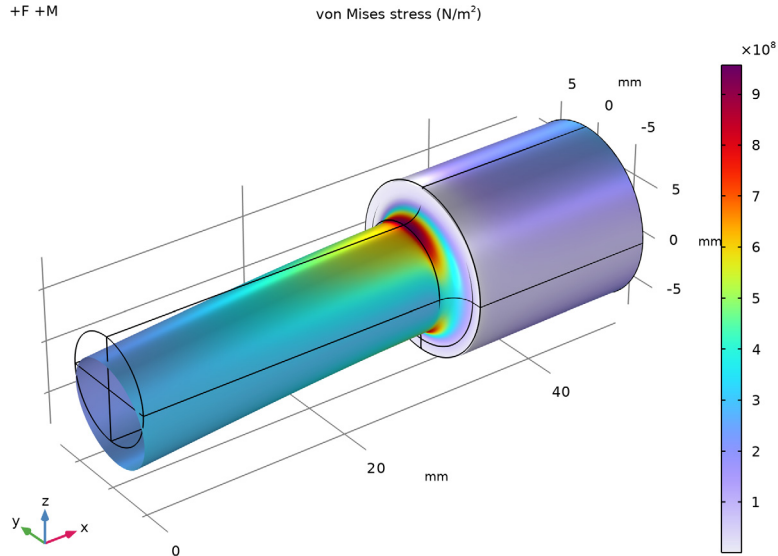

Figure 5: Equivalent stress distribution for one of the combined load cases.

The results from the fatigue evaluation is shown in Figure 6, Figure 7, and Figure 8. With the Findley criterion, the fatigue usage factor is computed to 0.98, in agreement with Ref. 1.

Using the Mataka criterion, the fatigue usage factor decreases to 0.89, which shows that there can be significant differences between results from seemingly similar models. The critical plane computed in the Mataka model differs from the one used in the Findley model. As a consequence, the maximum normal stress on the critical plane can be significantly lower in the Mataka case than in the Findley case.

The Dang Van model predicts the fatigue usage factor to 0.94. This is in agreement with the predicted value in Ref. 1.

The differences in fatigue usage factor arise from the fact that in the reference the shear stress arising from the constant bending force is approximated to zero. In reality, this shear force is 16% as compared with the shear force arising from the twisting moment and has an impact on the results. Moreover, when a comparison between different models is made, attention must be made to the discretization of the geometry. The critical point of each model is found in different locations. Thus, a perfect agreement in one model does not

mean that there will be a perfect agreement in another model. Based on the discretization, the evaluation for certain models is made closer to its critical point and thus results are in better agreement with the theoretical value. A stress state that is only a few percent from its theoretical value can have a larger impact on the fatigue prediction, since the fatigue model requires further data manipulation.

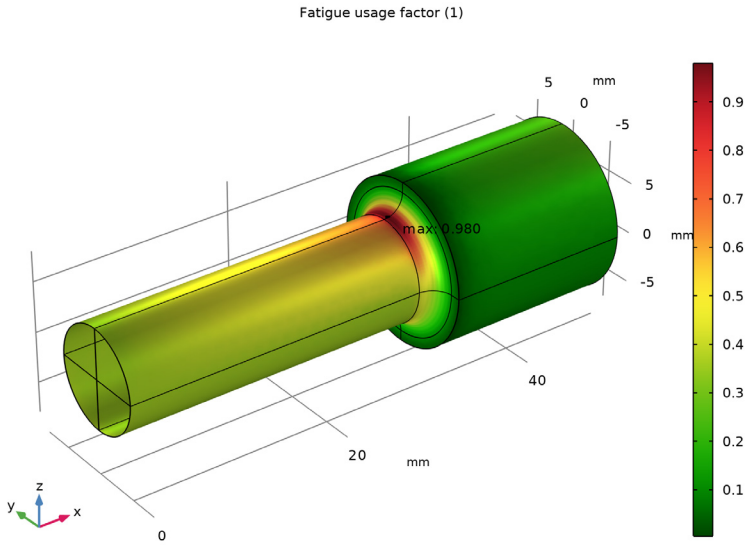

Figure 6: Fatigue usage factor using the Findley criterion.

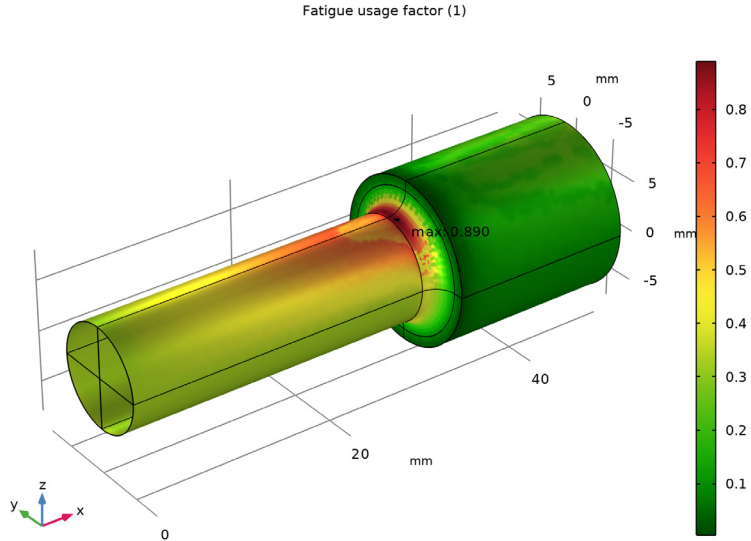

Figure 7: Fatigue usage factor using the Matak criterion.

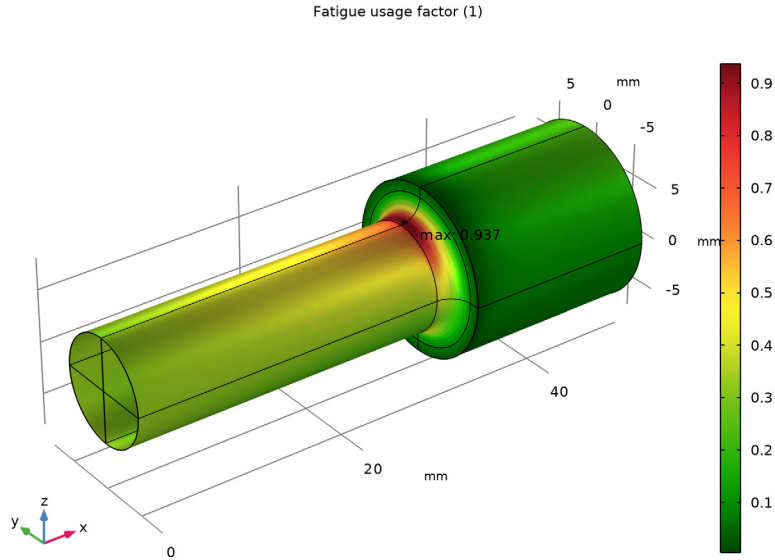

Figure 8: Fatigue usage factor using the Dang Van criterion.

There is a large difference in the fatigue usage factor between the top (tension) and bottom (compression) side of the bar (see [Figure 9](#)), even though the equivalent stress is the same at both locations. This shows how the criterion captures the difference between the predominantly tensile stress states at the critical spot and the compressive stress states on the other side. Moreover, there is a clear difference between the models. In tension, the Dang Van model predicts higher fatigue usage factor than the Mataka model, while in compression, this is reversed. Therefore, the computed values should not be taken as an exact prediction of the fatigue but rather as a probable outcome. Each model has a

preferred area of use and application in a slightly different domain can result in less accurate fatigue prediction.

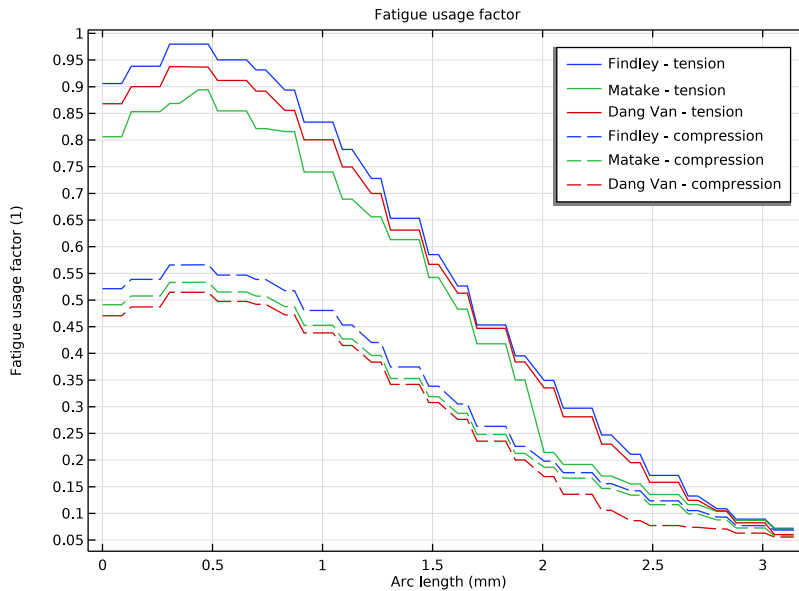

Figure 9: Fatigue usage factor prediction in tension and compression.

Notes About the COMSOL Implementation

In this model, you use the load case functionality in COMSOL Multiphysics to produce the load cycle. In the first study, the two basic load cases are analyzed. This study is not essential for the analysis, but it allows you to inspect the results of the individual basic load cases.

In order to resolve stresses on the surface of the shaft more accurately, it is clad with a thin layer of the same material. The computed surface stresses are then used in the fatigue evaluation.

Reference

1. D.F. Socie and G.B. Marquis, *Multiaxial Fatigue*, SAE, 1999.

Application Library path: Fatigue_Module/Stress_Based/shaft_with_fillet



Modeling Instructions

From the **File** menu, choose **New**.

NEW

In the **New** window, click  **Model Wizard**.

MODEL WIZARD

- 1 In the **Model Wizard** window, click  **3D**.
- 2 In the **Select Physics** tree, select **Structural Mechanics > Solid Mechanics (solid)**.
- 3 Click **Add**.
- 4 Click  **Study**.
- 5 In the **Select Study** tree, select **General Studies > Stationary**.
- 6 Click  **Done**.

GEOMETRY I

- 1 In the **Model Builder** window, under **Component I (comp1)** click **Geometry I**.
- 2 In the **Settings** window for **Geometry**, locate the **Units** section.
- 3 From the **Length unit** list, choose **mm**.

Work Plane 1 (wp1)

- 1 In the **Geometry** toolbar, click  **Work Plane**.
- 2 In the **Settings** window for **Work Plane**, click  **Go to Plane Geometry**.



Work Plane 1 (wp1) > Plane Geometry

In the **Model Builder** window, click **Plane Geometry**.

Work Plane 1 (wp1) > Polygon 1 (pol1)

- 1 In the **Work Plane** toolbar, click  **Polygon**.
- 2 In the **Settings** window for **Polygon**, locate the **Coordinates** section.
- 3 From the **Data source** list, choose **Vectors**.
- 4 In the **xw** text field, type 0 0 32 32 50 50 0.
- 5 In the **yw** text field, type 0 5 5 8 8 0 0.

Work Plane 1 (wp1) > Fillet 1 (fill)

- 1 In the **Work Plane** toolbar, click  **Fillet**.
- 2 On the object **poll**, select Point 3 only.
- 3 In the **Settings** window for **Fillet**, locate the **Radius** section.
- 4 In the **Radius** text field, type 2.
- 5 Click  **Build Selected**.

Revolve 1 (rev1)

- 1 In the **Model Builder** window, right-click **Geometry 1** and choose **Revolve**.
- 2 In the **Settings** window for **Revolve**, locate the **Revolution Angles** section.
- 3 Clear the **Keep original faces** checkbox.
- 4 Locate the **Revolution Axis** section. Find the **Direction of revolution axis** subsection. In the **xw** text field, type 1.
- 5 In the **yw** text field, type 0.
- 6 Click  **Build Selected**.

DEFINITIONS

Create the boundary selection that will be used for fatigue evaluation.

Selection for fatigue evaluation

- 1 In the **Model Builder** window, expand the **Component 1 (comp1) > Definitions** node.
- 2 Right-click **Definitions** and choose **Selections > Explicit**.
- 3 In the **Settings** window for **Explicit**, type Selection for fatigue evaluation in the **Label** text field.
- 4 Locate the **Input Entities** section. From the **Geometric entity level** list, choose **Boundary**.
- 5 Select the **Group by continuous tangent** checkbox.
- 6 Select Boundaries 4 and 16 only.

SOLID MECHANICS (SOLID)

Thin Layer 1

- 1 In the **Physics** toolbar, click  **Boundaries** and choose **Thin Layer**.
- 2 In the **Settings** window for **Thin Layer**, locate the **Boundary Selection** section.
- 3 From the **Selection** list, choose **Selection for fatigue evaluation**.
- 4 Locate the **Boundary Properties** section. In the L_{th} text field, type $1e-6[m]$.
- 5 Locate the **Thin Layer** section. From the **Approximation** list, choose **Membrane**.

Fixed Constraint 1

- 1 In the **Physics** toolbar, click  **Boundaries** and choose **Fixed Constraint**.
- 2 Select Boundaries 21–24 only.

Rigid Connector 1

- 1 In the **Physics** toolbar, click  **Boundaries** and choose **Rigid Connector**.
- 2 Select Boundaries 1, 3, 5, and 7 only.

Applied Force 1

- 1 In the **Physics** toolbar, click  **Attributes** and choose **Applied Force**.
- 2 In the **Settings** window for **Applied Force**, locate the **Applied Force** section.
- 3 Specify the **F** vector as

0	x
0	y
-1.94 [kN]	z

- 4 In the **Physics** toolbar, click  **Load Group** and choose **New Load Group**.

Rigid Connector 1

In the **Model Builder** window, click **Rigid Connector 1**.

Applied Moment 1

- 1 In the **Physics** toolbar, click  **Attributes** and choose **Applied Moment**.
- 2 In the **Settings** window for **Applied Moment**, locate the **Applied Moment** section.
- 3 Specify the **M** vector as

28.7 [N*m]	x
0	y
0	z

- 4 In the **Physics** toolbar, click  **Load Group** and choose **New Load Group**.

GLOBAL DEFINITIONS

Transverse force

- 1 In the **Model Builder** window, under **Global Definitions > Load and Constraint Groups** click **Load Group 1**.
- 2 In the **Settings** window for **Load Group**, type Transverse force in the **Label** text field.

3 In the **Parameter name** text field, type 1gF.

Twisting moment

1 In the **Model Builder** window, under **Global Definitions > Load and Constraint Groups** click **Load Group 2**.

2 In the **Settings** window for **Load Group**, type Twisting moment in the **Label** text field.

3 In the **Parameter name** text field, type 1gM.

Material 1 (mat1)

In the **Model Builder** window, under **Global Definitions** right-click **Materials** and choose **Blank Material**.

MATERIALS

Material Link 1 (matLnk1)

In the **Model Builder** window, under **Component 1 (comp1)** right-click **Materials** and choose **More Materials > Material Link**.

GLOBAL DEFINITIONS

Material 1 (mat1)

1 In the **Settings** window for **Material**, locate the **Material Contents** section.

2 In the table, enter the following settings:

Property	Variable	Value	Unit	Property group
Young's modulus	E	100 [GPa]	Pa	Young's modulus and Poisson's ratio
Poisson's ratio	nu	0	l	Young's modulus and Poisson's ratio
Density	rho	0	kg/m ³	Basic

Because fatigue usage is to be evaluated on the surface, you need to define a material on the boundaries.

MATERIALS

Material Link 2 (matLnk2)

1 Right-click **Materials** and choose **More Materials > Material Link**.

2 In the **Settings** window for **Material Link**, locate the **Geometric Entity Selection** section.

3 From the **Geometric entity level** list, choose **Boundary**.

4 From the **Selection** list, choose **Selection for fatigue evaluation**.

A finer mesh is needed in the fillet in order to resolve the stress concentration.

MESH I

Mapped I

1 In the **Mesh** toolbar, click  **More Generators** and choose **Mapped**.

2 Select Boundaries 9–12 only.

Size I

1 Right-click **Mapped I** and choose **Size**.

2 In the **Settings** window for **Size**, locate the **Element Size** section.

3 Click the **Custom** button.

4 Locate the **Element Size Parameters** section.

5 Select the **Maximum element size** checkbox. In the associated text field, type 0.4.

Free Tetrahedral I

In the **Mesh** toolbar, click  **Free Tetrahedral**.

Size I

1 Right-click **Free Tetrahedral I** and choose **Size**.

2 In the **Settings** window for **Size**, locate the **Element Size** section.

3 From the **Predefined** list, choose **Extra fine**.

4 Click  **Build All**.

STUDY I

Step 1: Stationary

1 In the **Model Builder** window, under **Study I** click **Step 1: Stationary**.

2 In the **Settings** window for **Stationary**, click to expand the **Study Extensions** section.

3 Select the **Define load cases** checkbox.

4 Click **Add** two times.

5 In the table, enter the following settings:

Load case	IgF	Weight	IgM	Weight
Transverse force	√	1.0		1.0
Twisting moment		1.0	√	1.0

- 6 In the **Model Builder** window, click **Study 1**.
- 7 In the **Settings** window for **Study**, type Study 1 (Basic load cases) in the **Label** text field.
- 8 In the **Study** toolbar, click  **Compute**.

RESULTS

Stress, Thin Layer (solid)



Visualize the difference between the tension and compression on the opposite sides of the shaft.

- 1 In the **Model Builder** window, under **Results** click **Stress, Thin Layer (solid)**.
- 2 In the **Stress, Thin Layer (solid)** toolbar, click  **Plot**.
- 3 In the **Settings** window for **3D Plot Group**, locate the **Data** section.
- 4 From the **Load case** list, choose **Transverse force**.

Surface 1

- 1 In the **Model Builder** window, expand the **Stress, Thin Layer (solid)** node, then click **Surface 1**.
- 2 In the **Settings** window for **Surface**, click **Replace Expression** in the upper-right corner of the **Expression** section. From the menu, choose **Component 1 (comp1) > Solid Mechanics > Stress > Stress tensor (spatial frame) - N/m² > solid.sGpxx - Stress tensor, xx-component**.
- 3 In the **Stress, Thin Layer (solid)** toolbar, click  **Plot**.

ADD STUDY

- 1 In the **Home** toolbar, click  **Add Study** to open the **Add Study** window.
- 2 Go to the **Add Study** window.
- 3 Find the **Studies** subsection. In the **Select Study** tree, select **General Studies > Stationary**.
- 4 Click the **Add Study** button in the window toolbar.
- 5 In the **Home** toolbar, click  **Add Study** to close the **Add Study** window.

STUDY 2

Step 1: Stationary

- 1 In the **Settings** window for **Stationary**, locate the **Study Extensions** section.
- 2 Select the **Define load cases** checkbox.
- 3 Click **Add** three times.

4 In the table, enter the following settings:

Load case	IgF	Weight	IgM	Weight
No load		1.0		1.0
+F -M	√	1.0	√	-1.0
+F +M	√	1.0	√	1.0

5 In the **Model Builder** window, click **Study 2**.

6 In the **Settings** window for **Study**, type Study 2 (Combined load cases) in the **Label** text field.

7 In the **Study** toolbar, click  **Compute**.

RESULTS

Stress, Thin Layer (solid) I

1 In the **Model Builder** window, expand the **Results > Stress, Thin Layer (solid) I** node, then click **Stress, Thin Layer (solid) I**.

2 In the **Stress, Thin Layer (solid) I** toolbar, click  **Plot**.

As a last step, perform a fatigue analysis on the load cycle.

ADD PHYSICS

1 In the **Home** toolbar, click  **Add Physics** to open the **Add Physics** window.

2 Go to the **Add Physics** window.

3 In the tree, select **Structural Mechanics > Fatigue (ftg)**.

4 Find the **Physics interfaces in study** subsection. In the table, clear the **Solve** checkboxes for **Study 1 (Basic load cases)** and **Study 2 (Combined load cases)**.

5 Click the **Add to Component I** button in the window toolbar.

6 In the **Home** toolbar, click  **Add Physics** to close the **Add Physics** window.

FATIGUE (FTG)

Findley

1 In the **Physics** toolbar, click  **Boundaries** and choose **Stress-Based**.

2 In the **Settings** window for **Stress-Based**, type Findley in the **Label** text field.

3 Locate the **Boundary Selection** section. From the **Selection** list, choose **Selection for fatigue evaluation**.

- 4 Locate the **Solution Field** section. From the **Physics interface** list, choose **Solid Mechanics (solid)**.
- 5 Locate the **Evaluation Settings** section. In the **Q** text field, type 16.

Matake

- 1 In the **Physics** toolbar, click  **Boundaries** and choose **Stress-Based**.
- 2 In the **Settings** window for **Stress-Based**, type Matake in the **Label** text field.
- 3 Locate the **Boundary Selection** section. From the **Selection** list, choose **Selection for fatigue evaluation**.
- 4 Locate the **Fatigue Model Selection** section. From the **Criterion** list, choose **Matake**.
- 5 Locate the **Solution Field** section. From the **Physics interface** list, choose **Solid Mechanics (solid)**.
- 6 Locate the **Evaluation Settings** section. In the **Q** text field, type 16.

Dang Van

- 1 In the **Physics** toolbar, click  **Boundaries** and choose **Stress-Based**.
- 2 In the **Settings** window for **Stress-Based**, type Dang Van in the **Label** text field.
- 3 Locate the **Boundary Selection** section. From the **Selection** list, choose **Selection for fatigue evaluation**.
- 4 Locate the **Fatigue Model Selection** section. From the **Criterion** list, choose **Dang Van**.
- 5 Locate the **Solution Field** section. From the **Physics interface** list, choose **Solid Mechanics (solid)**.

GLOBAL DEFINITIONS



Material 1 (mat1)

- 1 In the **Model Builder** window, under **Global Definitions > Materials** click **Material 1 (mat1)**.
- 2 In the **Settings** window for **Material**, locate the **Material Contents** section.
- 3 In the table, enter the following settings:

Property	Variable	Value	Unit	Property group
Normal stress sensitivity coefficient	k_Findley	0.23		Findley
Limit factor	f_Findley	440 [MPa]	Pa	Findley
Normal stress sensitivity coefficient	k_Matake	0.33		Matake

Property	Variable	Value	Unit	Property group
Limit factor	f_Matake	467 [MPa]	Pa	Matake
Hydrostatic stress sensitivity coefficient	a_DangVan	0.5	I	Dang Van
Limit factor	b_DangVan	467 [MPa]	Pa	Dang Van

ADD STUDY

- 1 In the **Home** toolbar, click  **Add Study** to open the **Add Study** window.
- 2 Go to the **Add Study** window.
- 3 Find the **Physics interfaces in study** subsection. In the table, clear the **Solve** checkbox for **Solid Mechanics (solid)**.
- 4 Find the **Studies** subsection. In the **Select Study** tree, select **Preset Studies for Selected Physics Interfaces > Fatigue**.
- 5 Click the **Add Study** button in the window toolbar.
- 6 In the **Home** toolbar, click  **Add Study** to close the **Add Study** window.

STUDY 3

Step 1: Fatigue

- 1 In the **Settings** window for **Fatigue**, locate the **Values of Dependent Variables** section.
- 2 Find the **Values of variables not solved for** subsection. From the **Settings** list, choose **User controlled**.
- 3 From the **Method** list, choose **Solution**.
- 4 From the **Study** list, choose **Study 2 (Combined load cases), Stationary**.
- 5 In the **Model Builder** window, click **Study 3**.
- 6 In the **Settings** window for **Study**, type Study 3 (Fatigue) in the **Label** text field.
- 7 In the **Study** toolbar, click  **Compute**.

RESULTS

Fatigue Usage Factor (Findley)

In the **Settings** window for **3D Plot Group**, type Fatigue Usage Factor (Findley) in the **Label** text field.

Surface 1

- 1 In the **Model Builder** window, expand the **Fatigue Usage Factor (Findley)** node, then click **Surface 1**.
- 2 In the **Settings** window for **Surface**, locate the **Expression** section.
- 3 In the **Expression** text field, type `ftg.stre1.fus`.

Fatigue Usage Factor (Matake)

- 1 In the **Model Builder** window, right-click **Fatigue Usage Factor (Findley)** and choose **Duplicate**.
- 2 In the **Settings** window for **3D Plot Group**, type `Fatigue Usage Factor (Matake)` in the **Label** text field.

Surface 1

- 1 In the **Model Builder** window, expand the **Fatigue Usage Factor (Matake)** node, then click **Surface 1**.
- 2 In the **Settings** window for **Surface**, locate the **Expression** section.
- 3 In the **Expression** text field, type `ftg.stre2.fus`.

Fatigue Usage Factor (Dang Van)

- 1 In the **Model Builder** window, right-click **Fatigue Usage Factor (Matake)** and choose **Duplicate**.
- 2 In the **Settings** window for **3D Plot Group**, type `Fatigue Usage Factor (Dang Van)` in the **Label** text field.

Surface 1

- 1 In the **Model Builder** window, expand the **Fatigue Usage Factor (Dang Van)** node, then click **Surface 1**.
- 2 In the **Settings** window for **Surface**, locate the **Expression** section.
- 3 In the **Expression** text field, type `ftg.stre3.fus`.

Compare fatigue results in tension and compression.

Fatigue Usage Factor, 1D

- 1 In the **Results** toolbar, click  **ID Plot Group**.
- 2 In the **Settings** window for **ID Plot Group**, type `Fatigue Usage Factor, 1D` in the **Label** text field.
- 3 Locate the **Data** section. From the **Dataset** list, choose **Study 3 (Fatigue)/Solution 3 (sol3)**.
- 4 Click to expand the **Title** section. From the **Title type** list, choose **Manual**.

5 In the **Title** text area, type **Fatigue usage factor**.

Line Graph 1

- 1 Right-click **Fatigue Usage Factor, ID** and choose **Line Graph**.
- 2 Select Edge 19 only.
- 3 In the **Settings** window for **Line Graph**, click **Replace Expression** in the upper-right corner of the **y-Axis Data** section. From the menu, choose **Component 1 (comp1) > Fatigue > ftg.stre1.fus - Fatigue usage factor - 1**.
- 4 Click to expand the **Legends** section. Select the **Show legends** checkbox.
- 5 From the **Legends** list, choose **Manual**.
- 6 In the table, enter the following settings:

Legends
Findley - tension

Line Graph 2

- 1 Right-click **Line Graph 1** and choose **Duplicate**.
- 2 In the **Settings** window for **Line Graph**, locate the **y-Axis Data** section.
- 3 In the **Expression** text field, type **ftg.stre2.fus**.
- 4 Locate the **Legends** section. In the table, enter the following settings:

Legends
Matake - tension

Line Graph 3

- 1 Right-click **Line Graph 2** and choose **Duplicate**.
- 2 In the **Settings** window for **Line Graph**, locate the **y-Axis Data** section.
- 3 In the **Expression** text field, type **ftg.stre3.fus**.
- 4 Locate the **Legends** section. In the table, enter the following settings:

Legends
Dang Van - tension

Line Graph 4

- 1 In the **Model Builder** window, right-click **Fatigue Usage Factor, ID** and choose **Line Graph**.
- 2 Select Edge 17 only.

- 3 In the **Settings** window for **Line Graph**, click **Replace Expression** in the upper-right corner of the **y-Axis Data** section. From the menu, choose **ftg.stre1.fus - Fatigue usage factor**.
- 4 Click to expand the **Coloring and Style** section. Find the **Line style** subsection. From the **Line** list, choose **Dashed**.
- 5 From the **Color** list, choose **Cycle (reset)**.
- 6 Locate the **Legends** section. Select the **Show legends** checkbox.
- 7 From the **Legends** list, choose **Manual**.
- 8 In the table, enter the following settings:

Legends
Findley - compression

Line Graph 5

- 1 Right-click **Line Graph 4** and choose **Duplicate**.
- 2 In the **Settings** window for **Line Graph**, locate the **y-Axis Data** section.
- 3 In the **Expression** text field, type **ftg.stre2.fus**.
- 4 Locate the **Coloring and Style** section. From the **Color** list, choose **Cycle**.
- 5 Locate the **Legends** section. In the table, enter the following settings:

Legends
Matake - compression

Line Graph 6

- 1 Right-click **Line Graph 5** and choose **Duplicate**.
- 2 In the **Settings** window for **Line Graph**, locate the **y-Axis Data** section.
- 3 In the **Expression** text field, type **ftg.stre3.fus**.
- 4 Locate the **Legends** section. In the table, enter the following settings:

Legends
Dang Van - compression

5 In the **Fatigue Usage Factor, ID** toolbar, click  **Plot**.

