



Model created in COMSOL Multiphysics 6.4

Fatigue Response of a Random Nonproportional Load

Introduction

A thin-walled frame member with a central cutout is subjected to a random load scenario. Although the stresses are expected to be far below the yield level of the material, a concern arises whether or not the component fails due to fatigue.

This example demonstrates an approach to damage quantification of a long load history. The rainflow counting algorithm is used to define the load scenario and the Palmgren–Miner linear damage model quantifies the damage.

Model Definition

The load carrying beam is shown in [Figure 1](#). It has a length of 1.1 m, a thin-walled square cross section having the dimension 160 mm x160 mm and a thickness of 6 mm. The cutout is centrally placed on one of the faces and is 100 mm long, 80 mm wide and has a fillet with radius 10 mm in each corner.

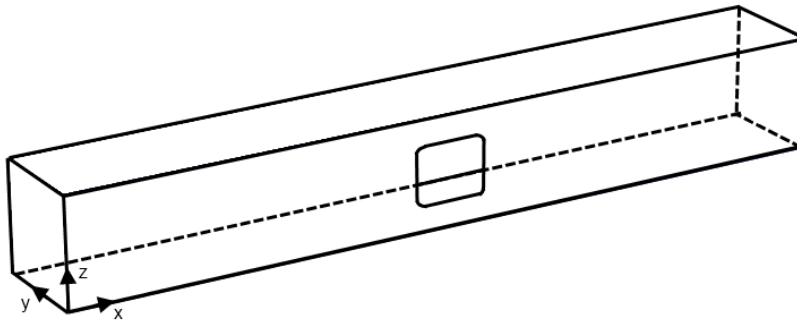

Figure 1: Geometry of the frame member.

The loading consists of bending moments in both directions and a twisting moment. All three loads can vary independently. The information about the load is obtained using three strain gauges, which are glued on the bottom and the back sides of the frame. The back side is the one opposite to the face with the hole. The location and position of the strain gauges are shown in [Figure 2](#). Strain gauges 1 and 2 are oriented at a 45° angle to the global coordinate system while the 3rd strain gauge is aligned with the length of the face (the x-axis). Both are located 850 mm from the edge along the length and in the middle along the width of the faces.

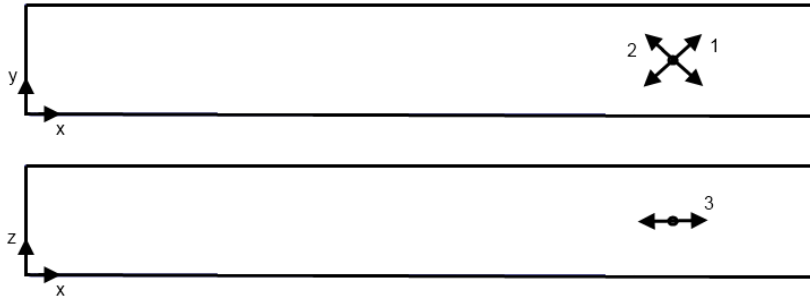

Figure 2: Location and orientation of the strain gauges.

The frame is made out of steel with Young's modulus, Poisson's ratio, and density given by $E = 200$ GPa, $\nu = 0.33$, and $\rho = 7800$ kg/m³, respectively.

The fatigue behavior is described by the material library data for iron alloy 4340 for a variant defined by phase **UTS 200 Ksi - 293K** and variation **unnotched**.

The left end of the structure, $x = 0$, is clamped. One twisting moment, along x , and two bending moments, along y and z , are applied on the right end at $x = 1.1$ m. The lifetime for which the frame is designed is 10,000 longer than what has been recorded by the strain gauges. The response to one loading cycle block in all three gauges is captured in Figure 3. From the history it is clear that the loading event is nonproportional. However, stress concentrations arise around the cutout where the stress state is uniaxial. Therefore the used models, Rainflow Counting and Palmgren–Miner summation, can be seen as appropriate for fatigue evaluation.

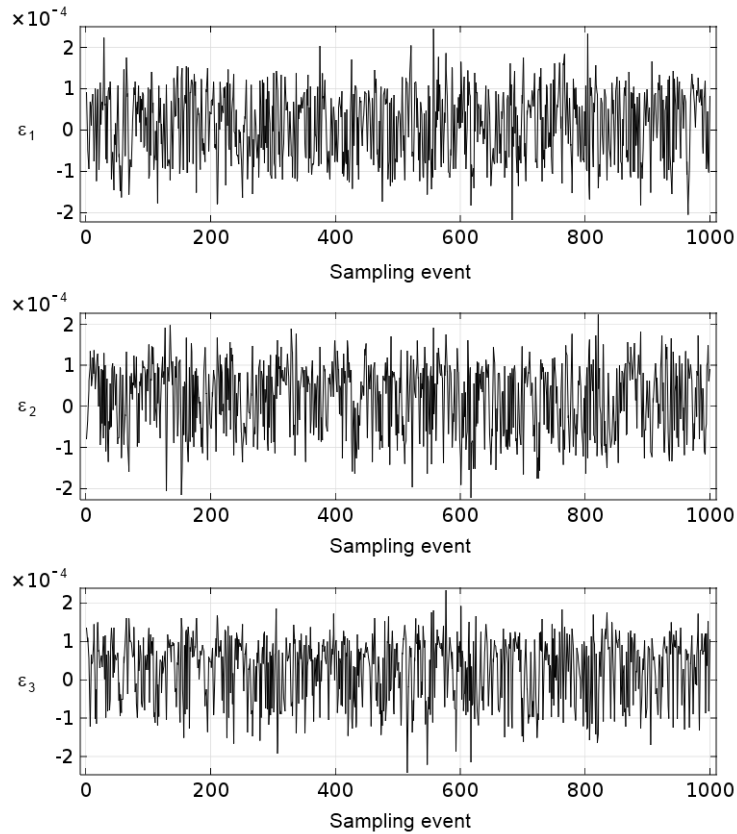

Figure 3: Strain history in the tree strain gauges. The subscript indicates the gauge number.

In order to apply the strain history to the frame, the strain history needs to be transferred to loads which can be applied on the boundary. The transformation can be done in two ways. In the first, a relation between a unit moment and a response in each strain gauge must be obtained using COMSOL Multiphysics. By repeating it for each unit moment and inverting the relation, a transformation matrix relating strains to moments is obtained.

An alternative way is to use an approximate analytical relation based on beam theory with a thin-walled assumption, Hooke's law, and rotation of stresses in a plane. The result is given below without a detailed derivation.

$$\begin{aligned}
\varepsilon_1 &= B_1(A_1C_1 + A_2D_1)M_Y + 2B_2(A_1C_3 + A_2D_3)M_X \\
\varepsilon_2 &= B_1(A_1D_1 + A_2C_1)M_Y + 2B_2(A_1D_3 + A_2C_3)M_X \\
\varepsilon_3 &= A_1B_1M_Z
\end{aligned} \tag{1}$$

where $A_1 = 1/E$, $A_2 = -\nu/E$, $B_1 = 3(b+t)/(4tb^3)$, $B_2 = 1/(2tb^2)$, $C_1 = \cos 45^\circ \cos 45^\circ$, $C_2 = \sin 45^\circ \sin 45^\circ$, $C_3 = \cos 45^\circ \sin 45^\circ$, $D_1 = \cos 135^\circ \cos 135^\circ$, $D_2 = \sin 135^\circ \sin 135^\circ$, and $D_3 = \cos 135^\circ \sin 135^\circ$. The variables $t = 6$ mm and $b = 154$ mm define the thickness and the side (using midsurfaces) of the cross section.

Based on the geometrical and material constants, [Equation 1](#) gives the following relation

$$\begin{bmatrix} \varepsilon_1 \\ \varepsilon_2 \\ \varepsilon_3 \end{bmatrix} = \begin{bmatrix} 2.34\text{e-}8 & -9.18\text{e-}9 & 0 \\ -2.34\text{e-}8 & -9.18\text{e-}9 & 0 \\ 0 & 0 & -2.73\text{e-}8 \end{bmatrix} \begin{bmatrix} M_X \\ M_Y \\ M_Z \end{bmatrix} \tag{2}$$

Results and Discussion

According to a finite element analysis the, applied moments and gauge strains are related by

$$\begin{bmatrix} \varepsilon_1 \\ \varepsilon_2 \\ \varepsilon_3 \end{bmatrix} = \begin{bmatrix} 2.62\text{e-}8 & -9.45\text{e-}9 & 0 \\ -2.62\text{e-}8 & -9.55\text{e-}9 & 0 \\ 0 & 0 & -2.86\text{e-}8 \end{bmatrix} \begin{bmatrix} M_X \\ M_Y \\ M_Z \end{bmatrix} \tag{3}$$

The coefficients differ somewhat when compared to the analytical results, [Equation 2](#). It is reasonable to assume that the final fatigue prediction also differs, depending on used transformation matrix. Since [Equation 2](#) is based on approximations, further results are based on the FE-relation, [Equation 3](#).

Stresses on the inner side of the shell are more critical from the fatigue point of view. The variation of the fatigue usage factor along the fillets is shown in [Figure 4](#). It reaches about 0.11 and thus the examined frame should not fail in fatigue.

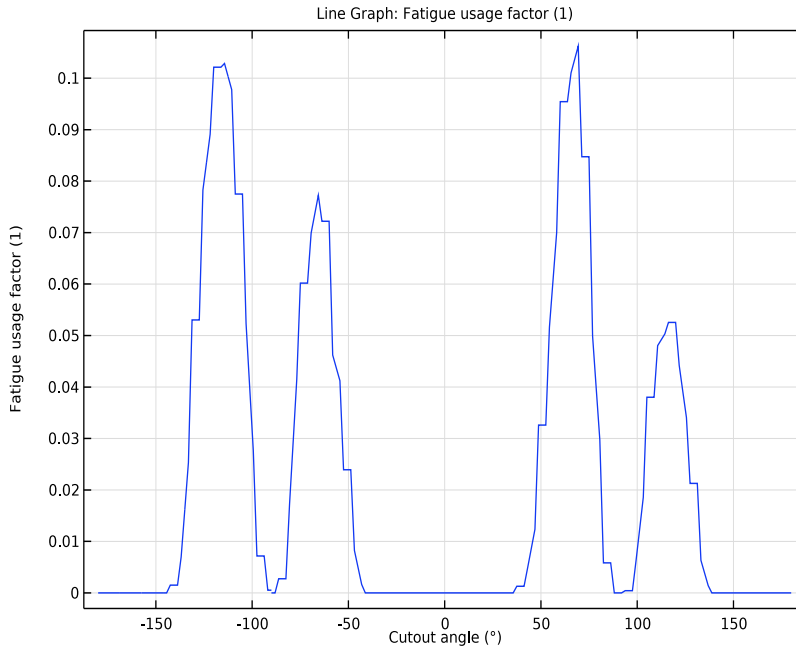

Figure 4: Fatigue usage factor along the cutout fillets. The angle is measured in the xz -plane with the angle starting from the x -axis.

In the most loaded point in the structure the stress history seems to be fairly symmetric around a zero mid stress. The mid stress is found in the range from -250 MPa to 250 MPa and the amplitude extend almost up to 600 MPa. The load distribution in the critical point is captured and shown in the Rainflow histogram in [Figure 5](#).

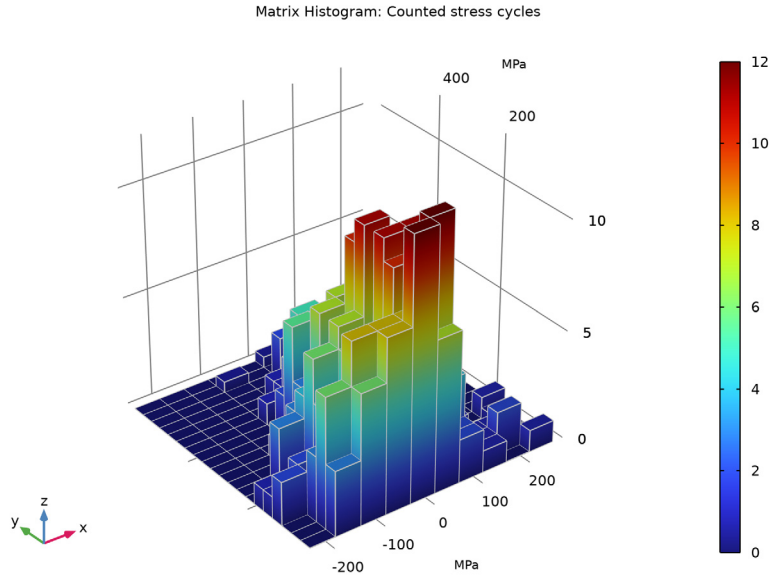

Figure 5: Cycle counting, following the rainflow theory, in the point of the highest fatigue usage factor.

In [Figure 6](#), the relative contribution to the damage is shown for the same location. The dark blue area indicates stress cycles which are nondamaging. This means that they are below the endurance limit in the Wöhler curve, also called the S-N curve. The damaging stress cycles are found for high stress amplitudes. Since the Palmgren–Miner rule scales damage linearly with the number of cycles, when the number of cycles increases by a factor 1/0.11, the fatigue usage factor exceeds 1 and thus a failure occurs. In practice, the linearity assumption of the Palmgren–Miner rule can be questioned, so a proper safety factor should be applied.

An important information when evaluating [Figure 5](#) and [Figure 6](#) is that 37% of the fatigue damage comes from one single event in the load history and that most damage is caused by only few load cycles. This indicates that the load history recorded is too short to make good predictions. Either a new, longer, measurements should be made, or a high safety factor should be used in combination with some statistical considerations.

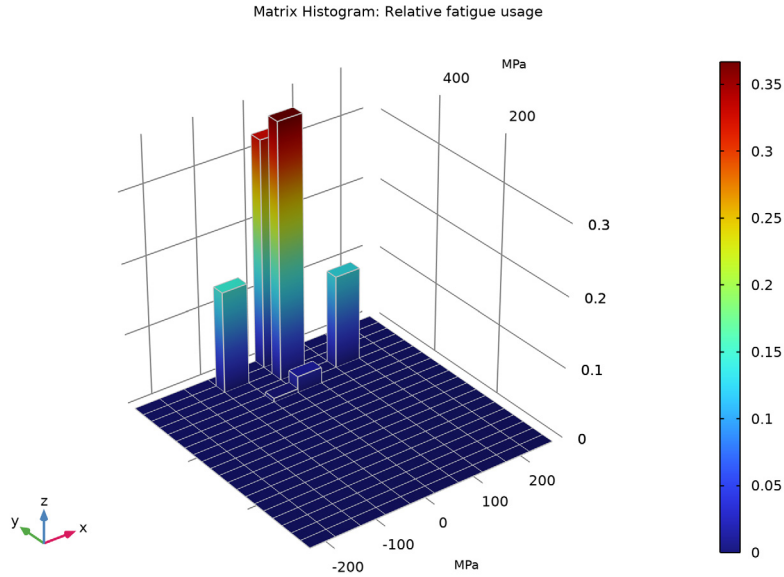

Figure 6: Relative fatigue usage, following the Palmgren–Miner damage rule, in the point with the highest usage factor.

Notes About the COMSOL Implementation

In COMSOL Multiphysics, several functions with the same argument list can be put in one file. This is demonstrated in the example with three load functions define the moment prescribed on one end of the frame. When an interpolation function is read from a file it treats the first columns as arguments and the following one as function response.

COMSOL Multiphysics provides several options for specification of the S-N curve. Interpolation function with options data type **Grid**, interpolation **Linear**, and extrapolation **Constant** is recommended. Those options are optimal for search of the life once R-value, and the amplitude stress are known. The input for S-N curve defined in the example is shown in [Figure 7](#).

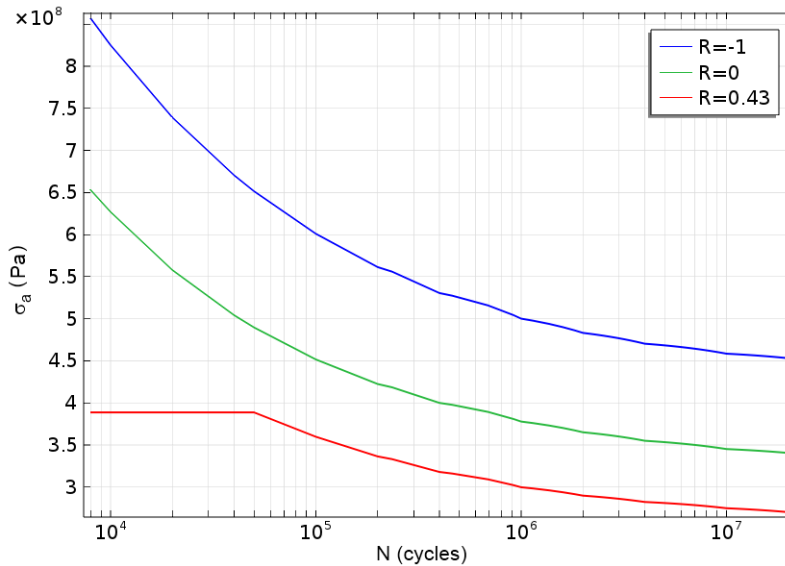

Figure 7: Wöhler curve of the material.

The fatigue material data in the material library gives the maximum fatigue stress, σ_{max} , as the function of the number of cycles and R-value. In order to transfer it to the stress amplitude, σ_a , which is required by the Cumulative Damage fatigue feature, just apply following transformation

$$\sigma_a = \frac{\sigma_{max}(1-R)}{2}$$

Application Library path: Fatigue_Module/Damage/frame_with_cutout



Modeling Instructions

From the **File** menu, choose **New**.

NEW

In the **New** window, click  **Model Wizard**.

MODEL WIZARD

- 1 In the **Model Wizard** window, click  **3D**.
- 2 In the **Select Physics** tree, select **Structural Mechanics > Shell (shell)**.
- 3 Click **Add**.
- 4 Click  **Study**.
- 5 In the **Select Study** tree, select **General Studies > Stationary**.
- 6 Click  **Done**.

GLOBAL DEFINITIONS

Parameters 1

- 1 In the **Model Builder** window, under **Global Definitions** click **Parameters 1**.
- 2 In the **Settings** window for **Parameters**, locate the **Parameters** section.
- 3 In the table, enter the following settings:

Name	Expression	Value	Description
M	1[N*m]	1 N·m	Unit moment
pt	6[mm]	0.006 m	Frame thickness
ch	80[mm]	0.08 m	Hole height
cw	100[mm]	0.1 m	Hole width
cr	10[mm]	0.01 m	Hole radius

GEOMETRY 1

Block 1 (blk1)

- 1 In the **Geometry** toolbar, click  **Block**.
- 2 In the **Settings** window for **Block**, locate the **Size and Shape** section.
- 3 In the **Width** text field, type 1.1.
- 4 In the **Depth** text field, type 0.154.
- 5 In the **Height** text field, type 0.154.
- 6 Locate the **Position** section. From the **Base** list, choose **Center**.

Work Plane 1 (wp1)

- 1 In the **Geometry** toolbar, click  **Work Plane**.
- 2 In the **Settings** window for **Work Plane**, locate the **Plane Definition** section.
- 3 From the **Plane type** list, choose **Face parallel**.

4 On the object **blk1**, select Boundary 3 only.

5 Click  **Go to Plane Geometry**.

Work Plane 1 (wp1) > Rectangle 1 (r1)

1 In the **Work Plane** toolbar, click  **Rectangle**.

2 In the **Settings** window for **Rectangle**, locate the **Position** section.

3 From the **Base** list, choose **Center**.

4 Locate the **Size and Shape** section. In the **Width** text field, type *ch*.

5 In the **Height** text field, type *cw*.

Work Plane 1 (wp1) > Fillet 1 (fil1)

1 In the **Work Plane** toolbar, click  **Fillet**.

2 On the object **r1**, select Points 1–4 only.

3 In the **Settings** window for **Fillet**, locate the **Radius** section.

4 In the **Radius** text field, type *cr*.

Create points for strain evaluation where strain gauges are placed.

Point 1 (pt1)

1 In the **Model Builder** window, right-click **Geometry 1** and choose **More Primitives > Point**.

2 In the **Settings** window for **Point**, locate the **Point** section.

3 In the **x** text field, type *0.3*.

4 In the **z** text field, type *-0.077*.

Point 2 (pt2)

1 In the **Geometry** toolbar, click  **More Primitives** and choose **Point**.

2 In the **Settings** window for **Point**, locate the **Point** section.

3 In the **x** text field, type *0.3*.

4 In the **y** text field, type *0.077*.

5 Click  **Build All Objects**.

DEFINITIONS

Create a new coordinate system that is aligned with the strain gauge directions on the bottom side of the frame.

Base Vector System 2 (sys2)

1 In the **Definitions** toolbar, click  **Coordinate Systems** and choose **Base Vector System**.

2 In the **Settings** window for **Base Vector System**, locate the **Base Vectors** section.

3 In the table, enter the following settings:

	x	y	z
x1	$\cos(\pi/4)$	$\sin(\pi/4)$	0
x2	$-\sin(\pi/4)$	$\cos(\pi/4)$	0

4 Find the **Simplifications** subsection. Select the **Assume orthonormal** checkbox.

5 Click the  **Wireframe Rendering** button in the **Graphics** toolbar.

SHELL (SHELL)

1 In the **Model Builder** window, under **Component 1 (comp1)** click **Shell (shell)**.

2 Select Boundaries 2–5 only.

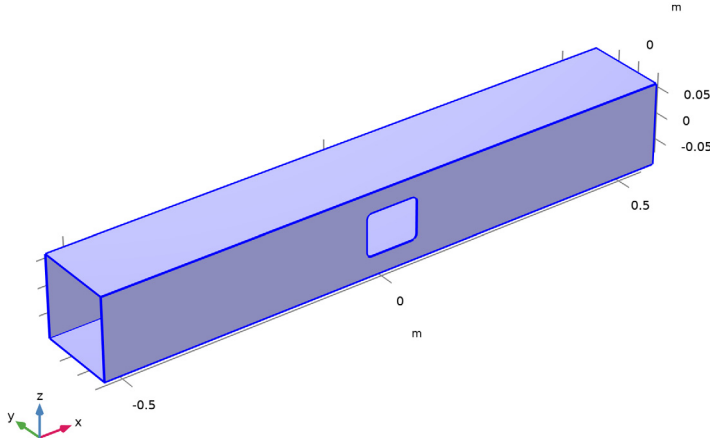

Thickness and Offset 1

1 In the **Model Builder** window, under **Component 1 (comp1)** > **Shell (shell)** click **Thickness and Offset 1**.

2 In the **Settings** window for **Thickness and Offset**, locate the **Thickness and Offset** section.

3 In the d_0 text field, type pt.

Linear Elastic Material 2

1 In the **Physics** toolbar, click  **Boundaries** and choose **Linear Elastic Material**.

2 Select Boundary 3 only.

Shell Local System 1

- 1 In the **Model Builder** window, expand the **Linear Elastic Material 2** node, then click **Shell Local System 1**.
- 2 In the **Settings** window for **Shell Local System**, locate the **Coordinate System Selection** section.
- 3 From the **Coordinate system** list, choose **Base Vector System 2 (sys2)**.

Prescribed Displacement/Rotation 1

- 1 In the **Physics** toolbar, click  **Edges** and choose **Prescribed Displacement/Rotation**.
- 2 Select Edges 1, 2, 4, and 6 only.

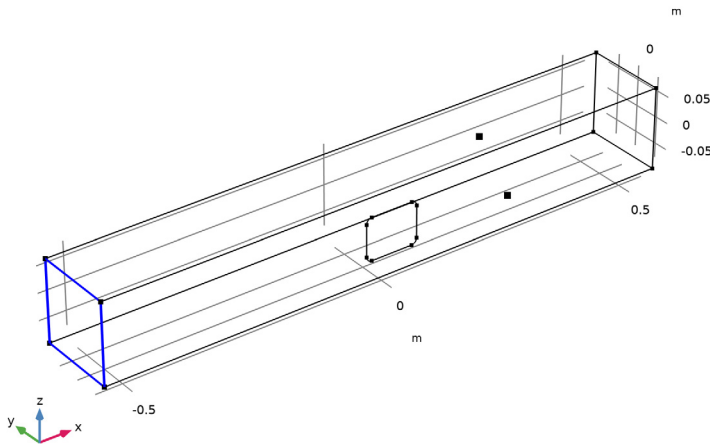

- 3 In the **Settings** window for **Prescribed Displacement/Rotation**, locate the **Prescribed Displacement** section.
- 4 From the **Displacement in x direction** list, choose **Prescribed**.
- 5 From the **Displacement in y direction** list, choose **Prescribed**.
- 6 From the **Displacement in z direction** list, choose **Prescribed**.

Apply one twisting and two bending unit moments and differentiate them using load cases.

Rigid Connector 1

- 1 In the **Physics** toolbar, click  **Edges** and choose **Rigid Connector**.

2 Select Edges 17–20 only.

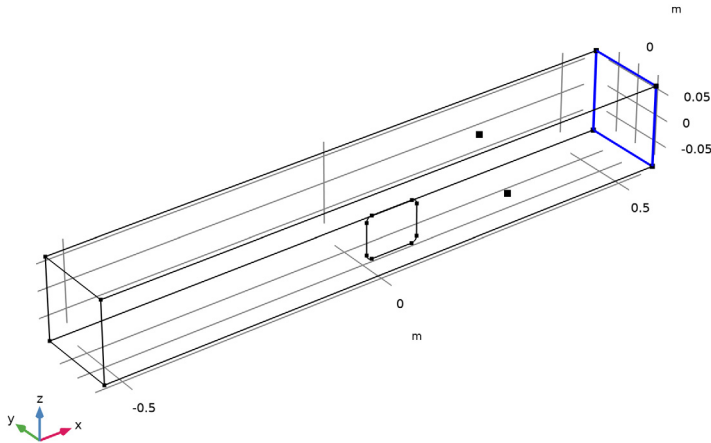

Twisting Moment (x)

- 1 In the **Physics** toolbar, click  **Attributes** and choose **Applied Moment**.
- 2 In the **Settings** window for **Applied Moment**, locate the **Applied Moment** section.
- 3 Specify the **M** vector as

M	x
0	y
0	z

- 4 In the **Label** text field, type **Twisting Moment (x)**.

Rigid Connector 1

In the **Model Builder** window, click **Rigid Connector 1**.

Bending Moment (y)

- 1 In the **Physics** toolbar, click  **Attributes** and choose **Applied Moment**.
- 2 In the **Settings** window for **Applied Moment**, locate the **Applied Moment** section.
- 3 Specify the **M** vector as

0	x
---	---

M	y
0	z

4 In the **Label** text field, type Bending Moment (y).

Rigid Connector I

In the **Model Builder** window, click **Rigid Connector I**.

Bending Moment (z)

- 1 In the **Physics** toolbar, click  **Attributes** and choose **Applied Moment**.
- 2 In the **Settings** window for **Applied Moment**, locate the **Applied Moment** section.
- 3 Specify the **M** vector as

0	x
0	y
M	z

4 In the **Label** text field, type Bending Moment (z).

Twisting Moment (x)

- 1 In the **Model Builder** window, click **Twisting Moment (x)**.
- 2 In the **Physics** toolbar, click  **Load Group** and choose **New Load Group**.

Bending Moment (y)

- 1 In the **Model Builder** window, click **Bending Moment (y)**.
- 2 Click  **Load Group** and choose **New Load Group**.

Bending Moment (z)

- 1 In the **Model Builder** window, click **Bending Moment (z)**.
- 2 Click  **Load Group** and choose **New Load Group**.

GLOBAL DEFINITIONS

Load Group: Mx

- 1 In the **Model Builder** window, under **Global Definitions > Load and Constraint Groups** click **Load Group I**.
- 2 In the **Settings** window for **Load Group**, type Load Group: Mx in the **Label** text field.
- 3 In the **Parameter name** text field, type lgX.

Load Group: My

- 1 In the **Model Builder** window, under **Global Definitions > Load and Constraint Groups** click **Load Group 2**.
- 2 In the **Settings** window for **Load Group**, type Load Group: My in the **Label** text field.
- 3 In the **Parameter name** text field, type 1gY.

Load Group: Mz

- 1 In the **Model Builder** window, under **Global Definitions > Load and Constraint Groups** click **Load Group 3**.
- 2 In the **Settings** window for **Load Group**, type Load Group: Mz in the **Label** text field.
- 3 In the **Parameter name** text field, type 1gZ.

MATERIALS

Material 1 (mat1)

- 1 In the **Model Builder** window, under **Component 1 (comp1)** right-click **Materials** and choose **Blank Material**.
- 2 Select Boundaries 2–5 only.
- 3 In the **Settings** window for **Material**, locate the **Material Contents** section.
- 4 In the table, enter the following settings:

Property	Variable	Value	Unit	Property group
Young's modulus	E	200e9	Pa	Young's modulus and Poisson's ratio
Poisson's ratio	nu	0.33	l	Young's modulus and Poisson's ratio
Density	rho	7800	kg/m ³	Basic

MESH 1

- 1 In the **Model Builder** window, under **Component 1 (comp1)** click **Mesh 1**.
- 2 In the **Settings** window for **Mesh**, locate the **Physics-Controlled Mesh** section.
- 3 From the **Element size** list, choose **Extremely fine**.
- 4 In the table, clear the **Use** checkbox for **Geometric Analysis, Detail Size**.
- 5 Click  **Build All**.

STUDY I

Step 1: Stationary

- 1 In the **Model Builder** window, under **Study I** click **Step 1: Stationary**.
- 2 In the **Settings** window for **Stationary**, click to expand the **Study Extensions** section.
- 3 Select the **Define load cases** checkbox.
- 4 Click **Add** three times.
- 5 In the table, enter the following settings:

Load case	IgX	Weight	IgY	Weight	IgZ	Weight
Load case X	√	1.0		1.0		1.0
Load case Y		1.0	√	1.0		1.0
Load case Z		1.0		1.0	√	1.0

- 6 In the **Model Builder** window, click **Study I**.
- 7 In the **Settings** window for **Study**, type Study: Generalized Loads in the **Label** text field.
- 8 In the **Study** toolbar, click  **Compute**.

RESULTS

Create a table showing the relation between gauge strain and each unit moment.

Point Evaluation 1

- 1 In the **Results** toolbar, click  **Point Evaluation**.
- 2 Select Point 13 only.
- 3 In the **Settings** window for **Point Evaluation**, click **Replace Expression** in the upper-right corner of the **Expressions** section. From the menu, choose **Component 1 (comp1) > Shell > Strain > Strain tensor, local coordinate system > shell.e11 - Strain tensor, local coordinate system, 11-component**.
- 4 Locate the **Expressions** section. In the table, enter the following settings:

Expression	Unit	Description
shell.e11	1	e1

5 Find the **Parameters** subsection. In the table, enter the following settings:

Name	Value	Unit	Description
shell.refpntx	1	m	Reference point for moment computation, x-coordinate

6 Click  **Evaluate**.

Point Evaluation 2

1 Right-click **Point Evaluation 1** and choose **Duplicate**.

2 In the **Settings** window for **Point Evaluation**, click **Replace Expression** in the upper-right corner of the **Expressions** section. From the menu, choose **Component 1 (comp1) > Shell > Strain > Strain tensor, local coordinate system > shell.e122 - Strain tensor, local coordinate system, 22-component**.

3 Locate the **Expressions** section. In the table, enter the following settings:

Expression	Unit	Description
shell.e122	1	e2

4 Click  **Evaluate**.

Point Evaluation 3

1 In the **Model Builder** window, under **Results > Derived Values** right-click **Point Evaluation 1** and choose **Duplicate**.

2 Select Point 14 only.

3 In the **Settings** window for **Point Evaluation**, locate the **Expressions** section.

4 In the table, enter the following settings:

Expression	Unit	Description
shell.e111	1	e3

5 Click  **Evaluate**.

GLOBAL DEFINITIONS



Load S-N curve.

Interpolation 1 (int1)



1 In the **Home** toolbar, click  **Functions** and choose **Global > Interpolation**.

2 In the **Settings** window for **Interpolation**, locate the **Definition** section.

3 From the **Data source** list, choose **File**.

- 4 Click  **Browse**.
- 5 Browse to the model's Application Libraries folder and double-click the file `frame_with_cutout_sn_curve.txt`.
- 6 Click  **null**.
Load twist and bending moments.



Interpolation 2 (int2)

- 1 In the **Home** toolbar, click  **Functions** and choose **Global > Interpolation**.
- 2 In the **Settings** window for **Interpolation**, locate the **Definition** section.
- 3 From the **Data source** list, choose **File**.
- 4 Click  **Browse**.
- 5 Browse to the model's Application Libraries folder and double-click the file `frame_with_cutout_load.txt`.
- 6 Click  **null**.
- 7 Locate the **Data Column Settings** section. In the table, enter the following settings:

Columns	Type	Settings
Column 2	Function values	Function name=int2a
Column 3	Function values	Function name=int2b

- 8 In the table, click to select the cell at row number 2 and column number 2.
- 9 In the **Name** text field, type `fX`.
- 10 In the table, click to select the cell at row number 3 and column number 2.
- 11 In the **Name** text field, type `fY`.
- 12 In the table, click to select the cell at row number 4 and column number 2.
- 13 In the **Name** text field, type `fZ`.

ADD PHYSICS

- 1 In the **Home** toolbar, click  **Add Physics** to open the **Add Physics** window.
- 2 Go to the **Add Physics** window.
- 3 In the tree, select **Structural Mechanics > Fatigue (ftg)**.
- 4 Find the **Physics interfaces in study** subsection. In the table, clear the **Solve** checkbox for **Study: Generalized Loads**.
- 5 Click the **Add to Component 1** button in the window toolbar.
- 6 In the **Home** toolbar, click  **Add Physics** to close the **Add Physics** window.

FATIGUE OUTSIDE

In the **Settings** window for **Fatigue**, type **Fatigue Outside** in the **Label** text field.

Cumulative Damage I

- 1 In the **Physics** toolbar, click  **Edges** and choose **Cumulative Damage**.
- 2 Select all edges around the cutout.

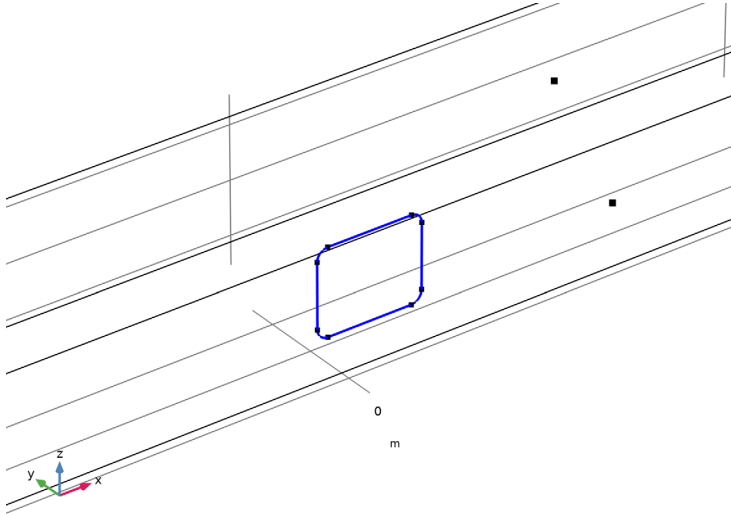



- 3 In the **Settings** window for **Cumulative Damage**, locate the **Solution Field** section.
 - 4 From the **Physics interface** list, choose **Shell (shell)**.
 - 5 From the **Through-thickness location** list, choose **Top**.
 - 6 Locate the **Analysis** section. From the **Type** list, choose **Generalized loads**.
 - 7 Locate the **Cycle Counting Parameters** section. Find the **Discretization** subsection. In the N_T text field, type 20.
 - 8 Locate the **Damage Model Parameters** section. In the m text field, type 10000.
 - 9 From the $f_{SN}(R, N)$ list, choose **int I**.
 - 10 Locate the **Generalized Load Definition** section. In the s_f text field, type 1000.
- 11 Click **+ Add** three times.

12 In the table, enter the following settings:

Generalized load history
fX
fY
fZ

ADD STUDY

- 1 In the **Home** toolbar, click  **Add Study** to open the **Add Study** window.
- 2 Go to the **Add Study** window.
- 3 Find the **Physics interfaces in study** subsection. In the table, clear the **Solve** checkbox for **Shell (shell)**.
- 4 Find the **Studies** subsection. In the **Select Study** tree, select **Preset Studies for Selected Physics Interfaces > Fatigue**.
- 5 Click the **Add Study** button in the window toolbar.
- 6 In the **Home** toolbar, click  **Add Study** to close the **Add Study** window.

STUDY 2

Step 1: Fatigue

- 1 In the **Settings** window for **Fatigue**, locate the **Values of Dependent Variables** section.
- 2 Find the **Values of variables not solved for** subsection. From the **Settings** list, choose **User controlled**.
- 3 From the **Method** list, choose **Solution**.
- 4 From the **Study** list, choose **Study: Generalized Loads, Stationary**.
- 5 In the **Model Builder** window, click **Study 2**.
- 6 In the **Settings** window for **Study**, type Study: Fatigue Outside in the **Label** text field.
- 7 In the **Study** toolbar, click  **Compute**.

RESULTS

Fatigue Usage Distribution (ftg), Fatigue Usage Factor (ftg), Stress Cycle Distribution (ftg)

Right-click and choose **Group**.

Fatigue Outside

In the **Settings** window for **Group**, type Fatigue Outside in the **Label** text field.

Fatigue Usage Factor (ftg)

Change the *x*-axis display to be an expression of the corner angles.

Line Graph 1

- 1 In the **Model Builder** window, expand the **Fatigue Usage Factor (ftg)** node, then click **Line Graph 1**.
- 2 In the **Settings** window for **Line Graph**, locate the **x-Axis Data** section.
- 3 From the **Parameter** list, choose **Expression**.
- 4 In the **Expression** text field, type
$$\text{atan2}(z-0.03, x-0.04) * (\text{dom}==15) + \text{atan2}(\text{abs}(z-0.03), x+0.04) * (\text{dom}==11) + \text{atan2}(z+0.03, x+0.04) * (\text{dom}==10) + \text{atan2}(z+0.03, x-0.04) * (\text{dom}==14)$$
- 5 From the **Unit** list, choose °.
- 6 Select the **Description** checkbox. In the associated text field, type Cutout angle.
- 7 In the **Fatigue Usage Factor (ftg)** toolbar, click  **Plot**.



Fatigue Usage Factor Outside (ftg)

- 1 In the **Model Builder** window, under **Results > Fatigue Outside** click **Fatigue Usage Factor (ftg)**.
- 2 In the **Settings** window for **ID Plot Group**, type Fatigue Usage Factor Outside (ftg) in the **Label** text field.

Stress Cycle Distribution Outside (ftg)

- 1 In the **Model Builder** window, under **Results > Fatigue Outside** click **Stress Cycle Distribution (ftg)**.
- 2 In the **Settings** window for **2D Plot Group**, type Stress Cycle Distribution Outside (ftg) in the **Label** text field.

Matrix Histogram 1



- 1 In the **Model Builder** window, expand the **Stress Cycle Distribution Outside (ftg)** node, then click **Matrix Histogram 1**.
- 2 In the **Settings** window for **Matrix Histogram**, locate the **Axes** section.
- 3 From the **Unit** list, choose **MPa**.
- 4 In the **Stress Cycle Distribution Outside (ftg)** toolbar, click  **Plot**.
- 5 Click the  **Zoom Extents** button in the **Graphics** toolbar.

Fatigue Usage Distribution Outside (ftg)



- 1 In the **Model Builder** window, under **Results > Fatigue Outside** click **Fatigue Usage Distribution (ftg)**.

- 2 In the **Settings** window for **2D Plot Group**, type **Fatigue Usage Distribution Outside (ftg)** in the **Label** text field.

Matrix Histogram 1

- 1 In the **Model Builder** window, expand the **Fatigue Usage Distribution Outside (ftg)** node, then click **Matrix Histogram 1**.
- 2 In the **Settings** window for **Matrix Histogram**, locate the **Axes** section.
- 3 From the **Unit** list, choose **MPa**.
- 4 In the **Fatigue Usage Distribution Outside (ftg)** toolbar, click  **Plot**.
- 5 Click the  **Zoom Extents** button in the **Graphics** toolbar.

ADD PHYSICS

- 1 In the **Home** toolbar, click  **Add Physics** to open the **Add Physics** window.
- 2 Go to the **Add Physics** window.
- 3 In the tree, select **Structural Mechanics > Fatigue (ftg)**.
- 4 Find the **Physics interfaces in study** subsection. In the table, clear the **Solve** checkboxes for **Study: Generalized Loads** and **Study: Fatigue Outside**.
- 5 Click the **Add to Component 1** button in the window toolbar.
- 6 In the **Home** toolbar, click  **Add Physics** to close the **Add Physics** window.

FATIGUE INSIDE

In the **Settings** window for **Fatigue**, type **Fatigue Inside** in the **Label** text field.

Cumulative Damage 1



- 1 In the **Physics** toolbar, click  **Edges** and choose **Cumulative Damage**.
- 2 Select all edges around the cutout.
- 3 In the **Settings** window for **Cumulative Damage**, locate the **Solution Field** section.
- 4 From the **Physics interface** list, choose **Shell (shell)**.
- 5 From the **Through-thickness location** list, choose **Bottom**.
- 6 Locate the **Analysis** section. From the **Type** list, choose **Generalized loads**.
- 7 Locate the **Cycle Counting Parameters** section. Find the **Discretization** subsection. In the N_T text field, type 20.
- 8 Locate the **Damage Model Parameters** section. In the m text field, type 10000.
- 9 From the $f_{SN}(R,N)$ list, choose **int I**.
- 10 Locate the **Generalized Load Definition** section. In the s_f text field, type 1000.

11 Click **Add** three times.

12 In the table, enter the following settings:

Generalized load history
fX
fY
fZ

ADD STUDY

- 1 In the **Home** toolbar, click  **Add Study** to open the **Add Study** window.
- 2 Go to the **Add Study** window.
- 3 Find the **Physics interfaces in study** subsection. In the table, clear the **Solve** checkboxes for **Shell (shell)** and **Fatigue Outside (ftg)**.
- 4 Find the **Studies** subsection. In the **Select Study** tree, select **Preset Studies for Selected Physics Interfaces > Fatigue**.
- 5 Click the **Add Study** button in the window toolbar.
- 6 In the **Home** toolbar, click  **Add Study** to close the **Add Study** window.

STUDY 3

Step 1: Fatigue

- 1 In the **Settings** window for **Fatigue**, locate the **Values of Dependent Variables** section.
- 2 Find the **Values of variables not solved for** subsection. From the **Settings** list, choose **User controlled**.
- 3 From the **Method** list, choose **Solution**.
- 4 From the **Study** list, choose **Study: Generalized Loads, Stationary**.
- 5 In the **Model Builder** window, click **Study 3**.
- 6 In the **Settings** window for **Study**, type Study: Fatigue Inside in the **Label** text field.
- 7 In the **Study** toolbar, click  **Compute**.

RESULTS

Fatigue Usage Distribution (ftg2), Fatigue Usage Factor (ftg2), Stress Cycle Distribution (ftg2)

Right-click and choose **Group**.

Fatigue Inside

In the **Settings** window for **Group**, type *Fatigue Inside* in the **Label** text field.

Fatigue Usage Factor Inside (ftg2)

- 1 In the **Model Builder** window, under **Results > Fatigue Inside** click **Fatigue Usage Factor (ftg2)**.
- 2 In the **Settings** window for **ID Plot Group**, type *Fatigue Usage Factor Inside (ftg2)* in the **Label** text field.



Line Graph 1

- 1 In the **Model Builder** window, expand the **Fatigue Usage Factor Inside (ftg2)** node, then click **Line Graph 1**.
- 2 In the **Settings** window for **Line Graph**, locate the **x-Axis Data** section.
- 3 From the **Parameter** list, choose **Expression**.
Define rounding position using an angle.
- 4 In the **Expression** text field, type
$$\text{atan2}(z-0.03, x-0.04) * (\text{dom}==15) + \text{atan2}(\text{abs}(z-0.03), x+0.04) * (\text{dom}==11) + \text{atan2}(z+0.03, x+0.04) * (\text{dom}==10) + \text{atan2}(z+0.03, x-0.04) * (\text{dom}==14)$$
- 5 From the **Unit** list, choose °.
- 6 Select the **Description** checkbox. In the associated text field, type *Cutout angle*.
- 7 In the **Fatigue Usage Factor Inside (ftg2)** toolbar, click  **Plot**.

Stress Cycle Distribution Inside (ftg2)

- 1 In the **Model Builder** window, under **Results > Fatigue Inside** click **Stress Cycle Distribution (ftg2)**.
- 2 In the **Settings** window for **2D Plot Group**, type *Stress Cycle Distribution Inside (ftg2)* in the **Label** text field.



Matrix Histogram 1

- 1 In the **Model Builder** window, expand the **Stress Cycle Distribution Inside (ftg2)** node, then click **Matrix Histogram 1**.
- 2 In the **Settings** window for **Matrix Histogram**, locate the **Axes** section.
- 3 From the **Unit** list, choose **MPa**.
- 4 In the **Stress Cycle Distribution Inside (ftg2)** toolbar, click  **Plot**.
- 5 Click the  **Zoom Extents** button in the **Graphics** toolbar.

Fatigue Usage Distribution Inside (ftg2)

- 1 In the **Model Builder** window, under **Results > Fatigue Inside** click **Fatigue Usage Distribution (ftg2)**.
- 2 In the **Settings** window for **2D Plot Group**, type Fatigue Usage Distribution Inside (ftg2) in the **Label** text field.

Matrix Histogram 1

- 1 In the **Model Builder** window, expand the **Fatigue Usage Distribution Inside (ftg2)** node, then click **Matrix Histogram 1**.
- 2 In the **Settings** window for **Matrix Histogram**, locate the **Axes** section.
- 3 From the **Unit** list, choose **MPa**.
- 4 In the **Fatigue Usage Distribution Inside (ftg2)** toolbar, click  **Plot**.
- 5 Click the  **Zoom Extents** button in the **Graphics** toolbar.