



Model created in COMSOL Multiphysics 6.4

High-Cycle Fatigue Analysis of a Cylindrical Test Specimen

Introduction

This is a benchmark model for the Fatigue Module. A cylindrical test specimen is subjected to nonproportional loading. Three stress based models — Findley, Matake, and Normal stress — are compared to analytical values and to each other. The nonsmooth behavior of the Matake model is captured and discussed.

Model Definition

A cylindrical test specimen with a geometry according to Figure 1 is subjected to fatigue testing. A combination of an axial force and a twisting moment is applied in such a way that the stress scenario shown in Figure 2 is affecting the central thin part of the specimen. The maximum shear stress is present at the outer radius of the bar.

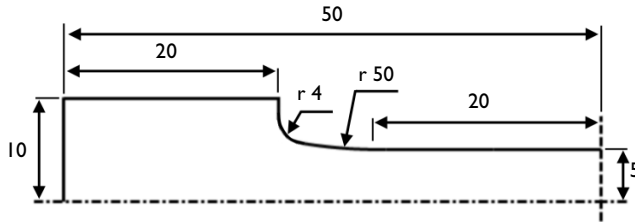

Figure 1: Geometry of the test specimen.

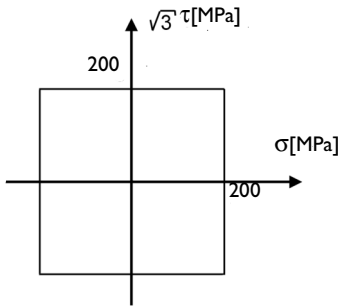

Figure 2: Stress history at the outer radius in the central part of the specimen.

This stress state can be simulated with a cyclic normal force of 15708 N and a cyclic twisting moment of 22.672 Nm.

The specimen is made from mild steel with a Young's modulus E of 210 GPa and a Poisson's ratio ν of 0.3.

The examined fatigue criteria are Findley, Matake, and Normal stress. Material parameters are calculated from uniaxial fatigue tests. Results from two tests are available.

In the first test, the material is tested in reversed tension-compression, which means that the stress amplitude is alternating around zero stress, and the endurance limit is found to be $\sigma_{R=-1} = 350$ MPa.

In the second test, the material is tested in pure tension, where the stress is pulsating between zero to two times the stress amplitude. The endurance limit is then $\sigma_{R=0} = 288$ MPa. The subscript of the endurance limit shows the R -value of the test.

Findley parameters are related to the fatigue test data via

$$f_F = \frac{\sigma_{R=-1}}{2}(k_F + \sqrt{1 + k_F^2})$$

$$f_F = \frac{\sigma_{R=0}}{2}(2k_F + \sqrt{1 + 4k_F^2})$$

and can thus be computed as $f_F = 213$ MPa and $k_F = 0.20$.

Matake parameters are related to the fatigue test data via

$$f_M = \frac{\sigma_{R=-1}}{2}(1 + k_M)$$

$$f_M = \frac{\sigma_{R=0}}{2}(1 + 2k_M)$$

which gives $f_M = 223$ MPa and $k_F = 0.27$. In the Normal stress model, the stress limit equals twice the stress amplitude of the fatigue test. The model does not take into account the R -value dependency, and therefore two different limits are obtained. In order to give conservative results, the lower limit, $\sigma_{R=0}$, is chosen and thus the model parameter is $f_N = 576$ MPa. This actually indicates that normal stress may not be a good criterion for this material.

Results and Discussion

The load cycle is obtained in four load steps. The resulting stress at the outer radius of the thin section follows the specification, see [Figure 3](#).

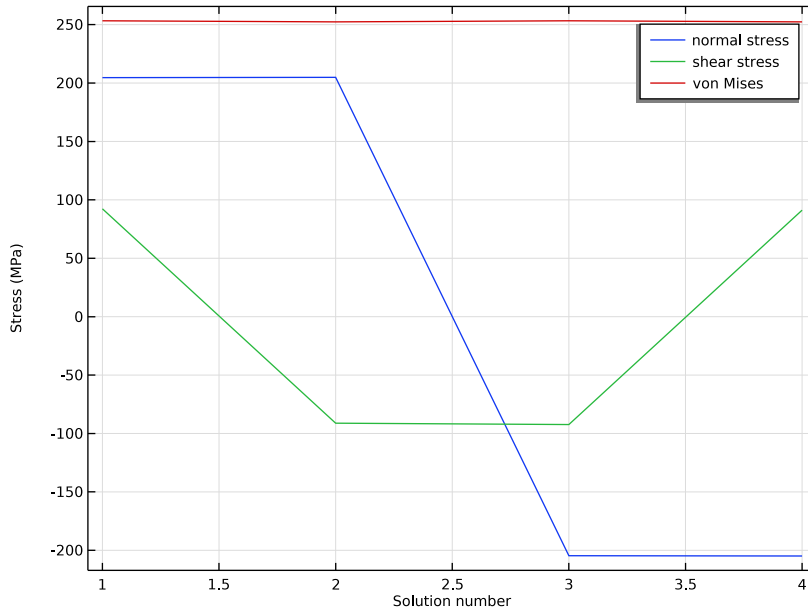

Figure 3: Resulting stresses at the outer radius of the smallest section of the specimen.

The three fatigue criteria evaluated on the boundary of the specimen are presented in [Figure 4](#), [Figure 5](#), and [Figure 6](#).

In this example, it is the central part of the specimen which is in focus for the evaluation, even though the maximum fatigue usage is slightly higher in the fillets.

The Findley model shows that the highest fatigue usage factor is found at the transition between the thin cylinder and the fillet, with the value being about 1.0, compared to 0.95

in the center. A smooth transition in the results indicates that the specified search resolution for the critical plane is sufficient to correctly capture the fatigue response.

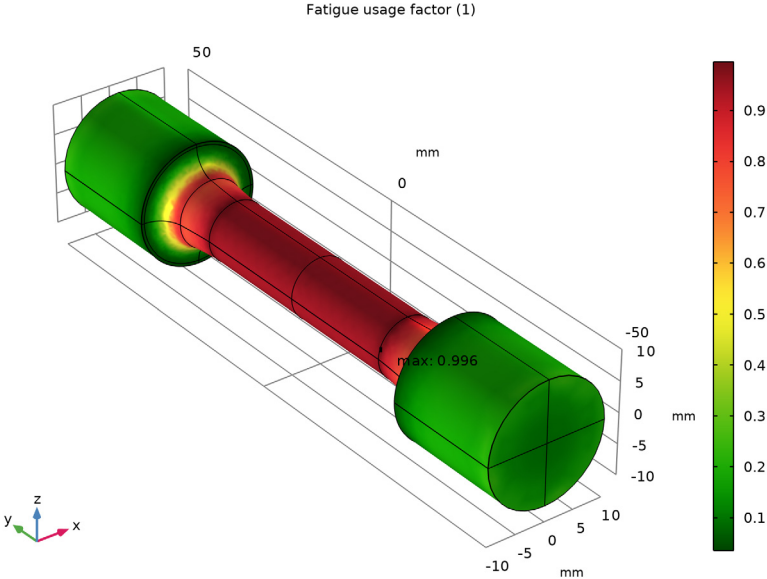

Figure 4: Fatigue usage factor Findley criterion.

The Mataka criterion gives less smooth results. The reason can be found in the definition of the criterion, which selects the critical plane using the shear stresses only and then adds the normal stress. This is discussed in more detail on [page 10](#). The analysis of the test

specimen predicts a fatigue usage factor in the range from 0.89 to 0.99 in the central part, as compared to 1.03 at some points at the transition from the thin cylinder to the notch.

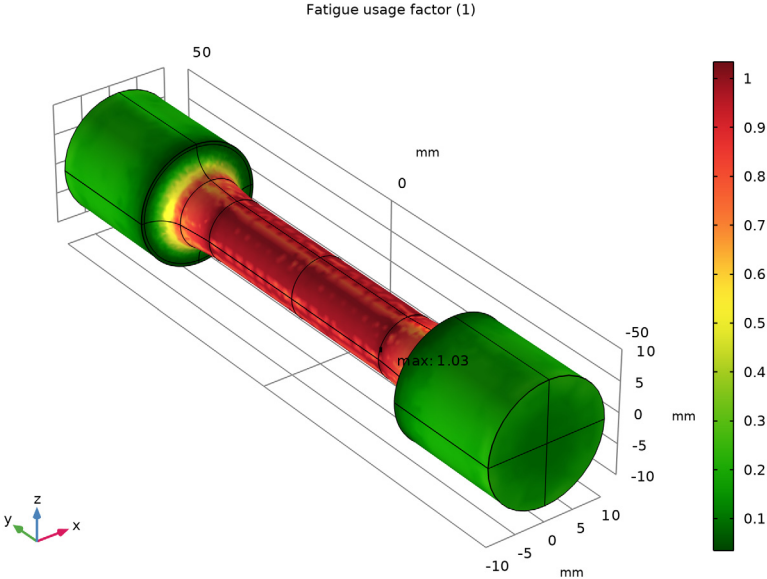

Figure 5: Fatigue usage factor Mataké criterion.

The Normal Stress criterion predicts yet another fatigue usage factor. Again, the highest fatigue usage factor is found on the transition from the thin section to the notch, 0.94, as compared to the center of the specimen, where it is 0.88.

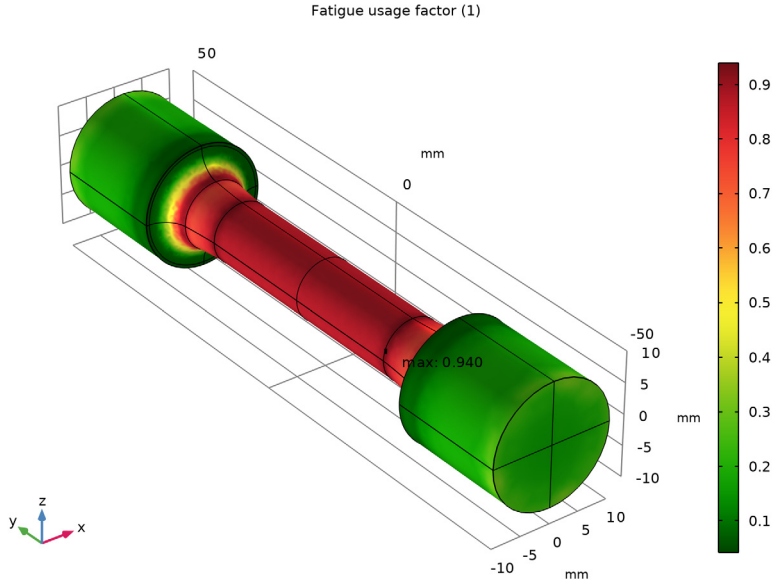

Figure 6: Fatigue usage factor Normal stress criterion.

The stress state on the surface in the central part of the specimen can be evaluated using analytical expressions. As there are no tractions on the boundary, it is in a state of plane stress. Therefore, the search for the critical plane can be reduced to two dimensions. In that case, the normal and shear stresses on a plane can be obtained as

$$\begin{aligned}\sigma(\varphi) &= \sigma_a \cos^2 \varphi + \sigma_b \sin^2 \varphi + \tau_{ab} \sin \varphi \cos \varphi \\ \tau(\varphi) &= \frac{\sigma_b - \sigma_a}{2} \sin 2\varphi + \tau_{ab} \cos 2\varphi\end{aligned}\quad (1)$$

where σ_a and σ_b are orthogonal normal stresses, and τ_{ab} is the shear stress. The orientation angle φ is calculated from the axis of σ_a toward σ_b . In the current example, the σ_a is the axial stress, and τ_{ab} as the shear stress caused by the twisting moment.

In the current example, a search resolution of $Q = 11$ is used. This gives a 9° angular increment in the critical plane evaluation. Using Equation 1, the normal and shear stresses

evaluated on discrete planes are given in [Table 1](#) and [Table 2](#). The number in the subscripts indicates the load case.

TABLE 1: NORMAL STRESS ON DISCRETE PLANES.

φ (°)	$\sigma_{n,1}$ (MPa)	$\sigma_{n,2}$ (MPa)	$\sigma_{n,3}$ (MPa)	$\sigma_{n,4}$ (MPa)	$\sigma_{n,max}$ (MPa)	$\Delta\sigma_n$ (MPa)
0	200	200	-200	-200	200	400
9	231	159	-231	-159	231	462
18	249	113	-249	-133	249	498
27	252	65	-252	-65	252	504
36	241	21	-241	-21	241	481
45	215	-15	-215	15	215	431
54	179	-41	-17	41	179	358
63	135	-52	-135	52	135	269
72	87	-49	-87	49	87	174
81	41	-31	-41	31	41	81
90	0	0	0	0	0	0
99	-31	41	31	-41	41	81
108	-49	87	49	-87	87	174
117	-52	135	52	-135	135	269
126	-41	179	41	-179	179	358
135	-15	215	15	-215	215	431
144	21	241	-21	-241	230	481
153	65	252	-65	-252	252	504
162	113	249	-113	-249	249	498
171	159	231	-159	231	231	462

TABLE 2: SHEAR STRESS ON DISCRETE PLANES.

φ (°)	τ_1 (MPa)	τ_2 (MPa)	τ_3 (MPa)	τ_4 (MPa)	$\Delta\tau$ (MPa)
0	115	-115	-115	115	230
9	79	-141	-79	141	281
18	35	-152	-35	152	304
27	-13	-149	13	149	298
36	-59	-131	59	131	262
45	-100	-100	100	100	200

TABLE 2: SHEAR STRESS ON DISCRETE PLANES.

φ (°)	τ_1 (MPa)	τ_2 (MPa)	τ_3 (MPa)	τ_4 (MPa)	$\Delta\tau$ (MPa)
54	-131	-59	131	59	262
63	-149	-13	149	13	298
72	-152	35	152	-35	304
81	-141	79	141	-79	281
90	-115	115	115	-115	231
99	-79	141	79	-141	281
108	-35	152	35	-152	304
117	13	149	-13	-149	298
126	59	131	-59	-131	262
135	100	100	-100	-100	200
144	131	59	-131	-59	262
153	149	13	-149	-13	298
162	152	-35	-152	35	304
171	141	-79	-141	79	281

The Findley criterion searches for a critical plane where a combination between the shear stress range and the normal stress is highest. This stress is shown in the second column of Table 3, where it can be seen that 202 MPa is found at planes oriented at 18° and 162°. This results into a usage factor of $202/213 = 0.95$, which is in good agreement with the computed results.

TABLE 3: FATIGUE STRESS.

φ (°)	$\Delta\tau/2+0.20\sigma_n$ (MPa)	$\Delta\tau/2+0.27\sigma_n$ (MPa)	$\Delta\sigma_n$ (MPa)
0	155	169	400
9	187	203	462
18	202	219	498
27	199	217	504
36	179	196	481
45	143	158	431
54	167	179	358
63	176	185	269
72	170	175	174
81	149	152	81
90	115	115	0

TABLE 3: FATIGUE STRESS.

φ (°)	$\Delta\tau/2+0.20\sigma_n$ (MPa)	$\Delta\tau/2+0.27\sigma_n$ (MPa)	$\Delta\sigma_n$ (MPa)
99	149	152	81
108	170	175	174
117	176	185	269
126	167	179	358
135	143	158	431
144	179	196	481
153	199	217	504
162	202	219	498
171	187	203	462

The Matake criterion selects the critical plane as the one with the largest shear stress range. This occurs at orientations 18° , 72° , 108° , and 162° where the range is 304 MPa, see Table 2. The maximum normal stress on those planes is either 87 MPa or 249 MPa, see Table 1 and the Matake stress is either 219 MPa or 175 MPa, see Table 3. Since the Matake criterion does not contain the normal stress in the selection of the critical plane, the fatigue criteria is calculated with either one of them. In Figure 5, this feature is demonstrated by the nonsmooth results. The analytical values at the critical planes for the Matake usage factor are $219/223 = 0.98$ and $175/223 = 0.78$, which is in good agreement with the computed results.

The Normal stress criterion considers the plane with the largest normal stress range. The last column of Table 3 shows that this is found on planes with orientations 27° and 153° where the range is 504 MPa. This results into a fatigue usage factor of $504/576 = 0.88$, which is in good agreement with the computed results.

Notes About the COMSOL Implementation

In the critical plane evaluation, a search resolution Q indicates the number of evaluation point along 90° of a unit circle. The angle between two evaluation points is then at most $(90^\circ)/(Q - 1)$.

Application Library path: Fatigue_Module/Verification_Examples/
cylindrical_test_specimen



Modeling Instructions

From the **File** menu, choose **New**.

NEW

In the **New** window, click  **Model Wizard**.

MODEL WIZARD

- 1 In the **Model Wizard** window, click  **3D**.
- 2 In the **Select Physics** tree, select **Structural Mechanics > Solid Mechanics (solid)**.
- 3 Click **Add**.
- 4 Click  **Study**.
- 5 In the **Select Study** tree, select **General Studies > Stationary**.
- 6 Click  **Done**.

GEOMETRY I

- 1 In the **Model Builder** window, under **Component 1 (comp1)** click **Geometry 1**.
- 2 In the **Settings** window for **Geometry**, locate the **Units** section.
- 3 From the **Length unit** list, choose **mm**.

GLOBAL DEFINITIONS

Parameters 1

- 1 In the **Model Builder** window, under **Global Definitions** click **Parameters 1**.
- 2 In the **Settings** window for **Parameters**, locate the **Parameters** section.
- 3 In the table, enter the following settings:

Name	Expression	Value	Description
Moment	22.672[N*m]	22.672 N·m	Twisting moment
Force	15708[N]	15708 N	Normal force

GEOMETRY I



Work Plane 1 (wp1)

- 1 In the **Geometry** toolbar, click  **Work Plane**.
- 2 In the **Settings** window for **Work Plane**, click  **Go to Plane Geometry**.

Work Plane 1 (wp1) > Plane Geometry

In the **Model Builder** window, click **Plane Geometry**.



Work Plane 1 (wp1) > Polygon 1 (pol1)

- 1 In the **Work Plane** toolbar, click  **Polygon**.
- 2 In the **Settings** window for **Polygon**, locate the **Object Type** section.
- 3 From the **Type** list, choose **Open curve**.
- 4 Locate the **Coordinates** section. From the **Data source** list, choose **Vectors**.
- 5 In the **xw** text field, type 5 5 0 0 10 10 6.01.
- 6 In the **yw** text field, type 20 0 0 50 50 30 30.
- 7 Click the  **Zoom Extents** button in the **Graphics** toolbar.

Work Plane 1 (wp1) > Quadratic Bézier 1 (qb1)

- 1 In the **Work Plane** toolbar, click  **More Primitives** and choose **Quadratic Bézier**.
- 2 In the **Settings** window for **Quadratic Bézier**, locate the **Control Points** section.
- 3 In row **1**, set **xw** to 6.01.
- 4 In row **2**, set **xw** to 5.25.
- 5 In row **3**, set **xw** to 5.
- 6 In row **1**, set **yw** to 30.
- 7 In row **2**, set **yw** to 25.
- 8 In row **3**, set **yw** to 20.

Work Plane 1 (wp1) > Convert to Solid 1 (csol1)



- 1 In the **Work Plane** toolbar, click  **Conversions** and choose **Convert to Solid**.
- 2 Click in the **Graphics** window and then press Ctrl+A to select both objects.
- 3 In the **Settings** window for **Convert to Solid**, click  **Build Selected**.

Work Plane 1 (wp1) > Fillet 1 (fil1)



- 1 In the **Work Plane** toolbar, click  **Fillet**.
- 2 On the object **csol1**, select Point 5 only.
- 3 In the **Settings** window for **Fillet**, locate the **Radius** section.
- 4 In the **Radius** text field, type 4.

Work Plane 1 (wp1) > Mirror 1 (mir1)



- 1 In the **Work Plane** toolbar, click  **Transforms** and choose **Mirror**.
- 2 Select the object **fill** only.

- 3 In the **Settings** window for **Mirror**, locate the **Normal Vector to Line of Reflection** section.
- 4 In the **xw** text field, type 0.
- 5 In the **yw** text field, type 1.
- 6 Locate the **Input** section. Select the **Keep input objects** checkbox.
- 7 Click  **Build Selected**.
- 8 Click the  **Zoom Extents** button in the **Graphics** toolbar.

Work Plane 1 (wp1) > Union 1 (uni1)

- 1 In the **Work Plane** toolbar, click  **Booleans and Partitions** and choose **Union**.
- 2 Click in the **Graphics** window and then press Ctrl+A to select both objects.
- 3 In the **Settings** window for **Union**, locate the **Union** section.
- 4 Clear the **Keep interior boundaries** checkbox.
- 5 In the **Work Plane** toolbar, click  **Build All**.

Revolve 1 (rev1)

- 1 In the **Model Builder** window, under **Component 1 (comp1) > Geometry 1** right-click **Work Plane 1 (wp1)** and choose **Revolve**.
- 2 In the **Settings** window for **Revolve**, locate the **Revolution Angles** section.
- 3 Clear the **Keep original faces** checkbox.
- 4 Click  **Build All Objects**.
- 5 Click the  **Zoom Extents** button in the **Graphics** toolbar.

MATERIALS

Material 1 (mat1)

- 1 In the **Model Builder** window, under **Component 1 (comp1)** right-click **Materials** and choose **Blank Material**.
- 2 In the **Settings** window for **Material**, locate the **Material Contents** section.
- 3 In the table, enter the following settings:

Property	Variable	Value	Unit	Property group
Young's modulus	E	210e9	Pa	Young's modulus and Poisson's ratio
Poisson's ratio	nu	0.3	l	Young's modulus and Poisson's ratio
Density	rho	7800	kg/m ³	Basic

SOLID MECHANICS (SOLID)

Fixed Constraint I

- 1 In the **Physics** toolbar, click  **Boundaries** and choose **Fixed Constraint**.
- 2 Select Boundaries 3, 4, 25, and 27 only.

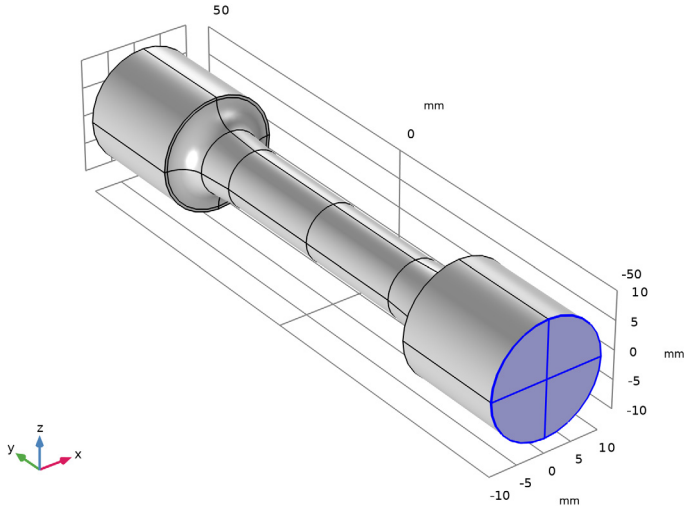

Rigid Connector I

- 1 In the **Physics** toolbar, click  **Boundaries** and choose **Rigid Connector**.
- 2 Select Boundaries 11, 12, 47, and 48 only.

Applied Force I

- 1 In the **Physics** toolbar, click  **Attributes** and choose **Applied Force**.
- 2 In the **Settings** window for **Applied Force**, locate the **Applied Force** section.
- 3 Specify the \mathbf{F} vector as

0	x
Force	y
0	z

- 4 In the **Physics** toolbar, click  **Load Group** and choose **New Load Group**.

Rigid Connector I

- In the **Model Builder** window, click **Rigid Connector I**.

Applied Moment 1

- 1 In the **Physics** toolbar, click  **Attributes** and choose **Applied Moment**.
- 2 In the **Settings** window for **Applied Moment**, locate the **Applied Moment** section.
- 3 Specify the **M** vector as

0	x
Moment	y
0	z

- 4 In the **Physics** toolbar, click  **Load Group** and choose **New Load Group**.

GLOBAL DEFINITIONS

Load Group: Force

- 1 In the **Model Builder** window, under **Global Definitions** > **Load and Constraint Groups** click **Load Group 1**.
- 2 In the **Settings** window for **Load Group**, type Load Group: Force in the **Label** text field.
- 3 In the **Parameter name** text field, type 1gF.

Load Group: Moment

- 1 In the **Model Builder** window, under **Global Definitions** > **Load and Constraint Groups** click **Load Group 2**.
- 2 In the **Settings** window for **Load Group**, type Load Group: Moment in the **Label** text field.
- 3 In the **Parameter name** text field, type 1gM.
Create a load cycle consisting of four load cases.

MESH 1

- 1 In the **Model Builder** window, under **Component 1 (comp1)** click **Mesh 1**.
- 2 In the **Settings** window for **Mesh**, locate the **Sequence Type** section.
- 3 From the list, choose **User-controlled mesh**.

Size

- 1 In the **Model Builder** window, under **Component 1 (comp1)** > **Mesh 1** click **Size**.
- 2 In the **Settings** window for **Size**, locate the **Element Size** section.
- 3 Click the **Predefined** button.
- 4 From the **Predefined** list, choose **Fine**.

Size 1

- 1 In the **Model Builder** window, click **Size 1**.
- 2 Select Boundaries 13–20, 30, 32–34, and 39–42 only.
- 3 In the **Settings** window for **Size**, locate the **Element Size** section.
- 4 Click the **Predefined** button.
- 5 From the **Predefined** list, choose **Finer**.
- 6 Click  **Build All**.

STUDY 1

Step 1: Stationary

- 1 In the **Model Builder** window, under **Study 1** click **Step 1: Stationary**.
- 2 In the **Settings** window for **Stationary**, click to expand the **Study Extensions** section.
- 3 Select the **Define load cases** checkbox.
- 4 Click **Add** four times.
- 5 In the table, enter the following settings:

Load case	IgF	Weight	IgM	Weight
Load case 1	√	1.0	√	1.0
Load case 2	√	1.0	√	-1.0
Load case 3	√	-1.0	√	-1.0
Load case 4	√	-1.0	√	1.0

- 6 In the **Study** toolbar, click  **Compute**.

RESULTS

Verify stresses at the center of the test specimen.

Stresses

- 1 In the **Results** toolbar, click  **ID Plot Group**.
- 2 In the **Settings** window for **ID Plot Group**, type **Stresses** in the **Label** text field.

Point Graph 1

- 1 Right-click **Stresses** and choose **Point Graph**.

2 Select Point 20 only.

It might be easier to select the correct point by using the **Selection List** window. To open this window, in the **Home** toolbar click **Windows** and choose **Selection List**. (If you are running the cross-platform desktop, you find **Windows** in the main menu.)

3 In the **Settings** window for **Point Graph**, click **Replace Expression** in the upper-right corner of the **y-Axis Data** section. From the menu, choose **Component 1 (comp1) > Solid Mechanics > Stress > Second Piola–Kirchhoff stress (material and geometry frames) - N/m² > solid.SGpYY - Second Piola–Kirchhoff stress, YY-component**.

4 Locate the **y-Axis Data** section. From the **Unit** list, choose **MPa**.

5 Click to expand the **Legends** section. Select the **Show legends** checkbox.

6 From the **Legends** list, choose **Manual**.

7 In the table, enter the following settings:

Legends

normal stress

Point Graph 2

1 Right-click **Point Graph 1** and choose **Duplicate**.

2 In the **Settings** window for **Point Graph**, locate the **y-Axis Data** section.

3 In the **Expression** text field, type `solid.SGpXY`.

4 Locate the **Legends** section. In the table, enter the following settings:

Legends

shear stress

Point Graph 3

1 Right-click **Point Graph 2** and choose **Duplicate**.

2 In the **Settings** window for **Point Graph**, locate the **y-Axis Data** section.

3 In the **Expression** text field, type `solid.misesGp`.

4 Locate the **Legends** section. In the table, enter the following settings:

Legends

von Mises

Stresses

1 In the **Model Builder** window, click **Stresses**.

2 In the **Settings** window for **ID Plot Group**, click to expand the **Title** section.

- 3 From the **Title type** list, choose **None**.
- 4 Locate the **Plot Settings** section.
- 5 Select the **y-axis label** checkbox. In the associated text field, type **Stress (MPa)**.
- 6 In the **Stresses** toolbar, click  **Plot**.

ADD PHYSICS

- 1 In the **Home** toolbar, click  **Add Physics** to open the **Add Physics** window.
- 2 Go to the **Add Physics** window.
- 3 In the tree, select **Structural Mechanics > Fatigue (ftg)**.
- 4 Find the **Physics interfaces in study** subsection. In the table, clear the **Solve** checkbox for **Study I**.
- 5 Click the **Add to Component I** button in the window toolbar.

FATIGUE FINDLEY

In the **Settings** window for **Fatigue**, type **Fatigue Findley** in the **Label** text field.

Stress-Based I

- 1 In the **Physics** toolbar, click  **Boundaries** and choose **Stress-Based**.
- 2 In the **Settings** window for **Stress-Based**, locate the **Boundary Selection** section.
- 3 From the **Selection** list, choose **All boundaries**.
- 4 Locate the **Solution Field** section. From the **Physics interface** list, choose **Solid Mechanics (solid)**.

ADD PHYSICS

- 1 Go to the **Add Physics** window.
- 2 In the tree, select **Structural Mechanics > Fatigue (ftg)**.
- 3 Find the **Physics interfaces in study** subsection. In the table, clear the **Solve** checkbox for **Study I**.
- 4 Click the **Add to Component I** button in the window toolbar.

FATIGUE MATAKE

- 1 In the **Settings** window for **Fatigue**, type **Fatigue Mataka** in the **Label** text field.
- 2 In the **Physics** toolbar, click  **Boundaries** and choose **Stress-Based**.
- 1 In the **Settings** window for **Stress-Based**, locate the **Boundary Selection** section.
- 2 From the **Selection** list, choose **All boundaries**.

- 3 Locate the **Fatigue Model Selection** section. From the **Criterion** list, choose **Matake**.
- 4 Locate the **Solution Field** section. From the **Physics interface** list, choose **Solid Mechanics (solid)**.

ADD PHYSICS

- 1 Go to the **Add Physics** window.
- 2 In the tree, select **Structural Mechanics > Fatigue (ftg)**.
- 3 Find the **Physics interfaces in study** subsection. In the table, clear the **Solve** checkbox for **Study 1**.
- 4 Click the **Add to Component 1** button in the window toolbar.
- 5 In the **Home** toolbar, click  **Add Physics** to close the **Add Physics** window.

FATIGUE NORMAL STRESS

- 1 In the **Settings** window for **Fatigue**, type **Fatigue Normal Stress** in the **Label** text field.
- 2 In the **Physics** toolbar, click  **Boundaries** and choose **Stress-Based**.
- 1 In the **Settings** window for **Stress-Based**, locate the **Boundary Selection** section.
- 2 From the **Selection** list, choose **All boundaries**.
- 3 Locate the **Fatigue Model Selection** section. From the **Criterion** list, choose **Normal stress**.
- 4 Locate the **Solution Field** section. From the **Physics interface** list, choose **Solid Mechanics (solid)**.

MATERIALS



Material 2 (mat2)

- 1 In the **Model Builder** window, under **Component 1 (comp1)** right-click **Materials** and choose **Blank Material**.
- 2 In the **Settings** window for **Material**, locate the **Geometric Entity Selection** section.
- 3 From the **Geometric entity level** list, choose **Boundary**.
- 4 From the **Selection** list, choose **All boundaries**.
- 5 Locate the **Material Contents** section. In the table, enter the following settings:

Property	Variable	Value	Unit	Property group
Normal stress sensitivity coefficient	k_Findley	0.20	1	Findley
Limit factor	f_Findley	213 [MPa]	Pa	Findley

Property	Variable	Value	Unit	Property group
Normal stress sensitivity coefficient	k_Matake	0.27	l	Matake
Limit factor	f_Matake	223 [MPa]	Pa	Matake
Limit factor	f_NormalStress	576 [MPa]	Pa	Normal stress

ADD STUDY

- 1 In the **Home** toolbar, click  **Add Study** to open the **Add Study** window.
- 2 Go to the **Add Study** window.
- 3 Find the **Physics interfaces in study** subsection. In the table, clear the **Solve** checkbox for **Solid Mechanics (solid)**.
- 4 Find the **Studies** subsection. In the **Select Study** tree, select **Preset Studies for Selected Physics Interfaces > Fatigue**.
- 5 Click the **Add Study** button in the window toolbar.
- 6 In the **Home** toolbar, click  **Add Study** to close the **Add Study** window.

STUDY 2

Step 1: Fatigue

- 1 In the **Settings** window for **Fatigue**, locate the **Values of Dependent Variables** section.
- 2 Find the **Values of variables not solved for** subsection. From the **Settings** list, choose **User controlled**.
- 3 From the **Method** list, choose **Solution**.
- 4 From the **Study** list, choose **Study 1, Stationary**.
- 5 In the **Study** toolbar, click  **Compute**.

RESULTS

Fatigue Usage Factor (Findley)

In the **Settings** window for **3D Plot Group**, type Fatigue Usage Factor (Findley) in the **Label** text field.

Fatigue Usage Factor (Matake)

- 1 In the **Model Builder** window, under **Results** click **Fatigue Usage Factor (ftg2)**.
- 2 In the **Settings** window for **3D Plot Group**, type Fatigue Usage Factor (Matake) in the **Label** text field.

Fatigue Usage Factor (Normal Stress)

- 1** In the **Model Builder** window, under **Results** click **Fatigue Usage Factor (ftg3)**.
- 2** In the **Settings** window for **3D Plot Group**, type Fatigue Usage Factor (Normal Stress) in the **Label** text field.