



Model created in COMSOL Multiphysics 6.4

Elastoplastic Low-Cycle Fatigue Analysis of Cylinder with a Hole

Introduction

A load carrying part of a structure is subjected to multi-axial cyclic loading during which localized yielding of the material occurs. In this model you perform a low cycle fatigue analysis of the part based on the Smith–Watson–Topper (SWT) model. Due to localized yielding, you can use two methods to obtain the stress and strain distributions for the fatigue evaluation. The first method is a full elastoplastic analysis with kinematic hardening, while the second is a linear elastic analysis with Neuber correction for plasticity. This example explores the first method. In the model [Notch Approximation in Low-Cycle Fatigue Analysis of Cylinder with a Hole](#), the same problem is solved using the elastic (Neuber) approach.

Model Definition

GEOMETRY

A cylinder contains a hole, drilled perpendicularly to its axis. The outer and inner diameters of the cylinder are 200 and 180 mm respectively. Its height is 100 mm. The diameter of the hole is 20 mm. The cylinder is loaded by an axial force which varies in time.

As the structure and loading contains several symmetries, you may model only 1/8 of the cylinder, as shown in [Figure 1](#).

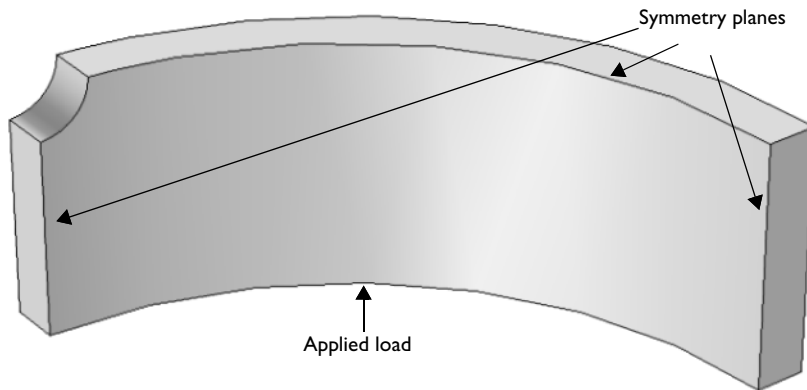

Figure 1: Model geometry with constrained and loaded faces.

MATERIAL PROPERTIES

- Elastic data: Isotropic with $E = 210$ GPa, $\nu = 0.3$

- Kinematic hardening plasticity data: Yield stress 380 MPa, Tangent modulus 75 GPa
- Fatigue parameters for the SWT equation:
 - $\sigma_f' = 1323$ MPa
 - $b = -0.097$
 - $\epsilon_f' = 0.375$
 - $c = -0.60$

CONSTRAINTS

Apply symmetry conditions on the three symmetry sections shown in [Figure 1](#).

LOAD

The loaded boundary of the cylinder is subjected to a pressure of 200 MPa having a sinusoidal variation with time. Since the problem is quasi static, time is not used explicitly in the problem. Instead you model the load as a function of a parameter, and use the parametric solver to trace the history.

Results and Discussion

The von Mises stress when the maximum load is reached for the first time (at a parameter value of 0.25) is shown in [Figure 2](#). Notice that the yield limit 380 MPa is exceeded by a large factor, and you can therefore expect significant plastic strains.

After completion of the first load cycle, there are no external loads. The internal residual stresses are still high, as can be seen in [Figure 3](#).

For a point located on the face of the hole and in the XY symmetry plane, the highest stresses appear in the Z direction. In [Figure 4](#), you can follow the development of the normal stress and strain in this direction during the first load cycle. The accumulation of plastic strain is shown in [Figure 5](#). This repetitive plastic deformation can be viewed as driving the generation of a fatigue crack.

After having run a second load cycle, the stress-strain loop repeats itself, and you can consider the process to have reached a steady state condition. This is shown in [Figure 6](#). The continuation of the equivalent plastic strain history is shown in [Figure 7](#).

para(11)=0.25

Volume: von Mises stress (MPa)

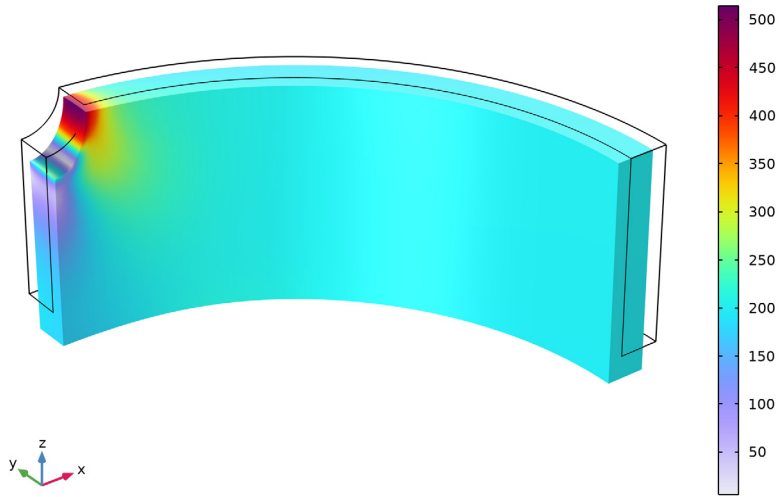

Figure 2: von Mises stress level at the first maximum load.

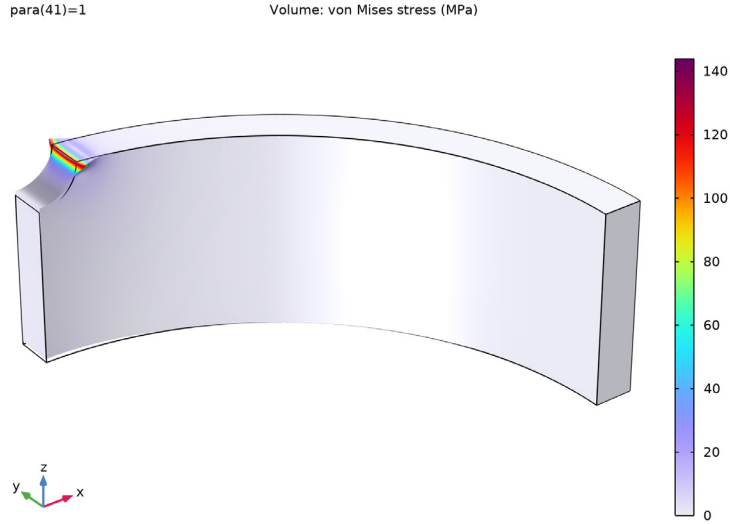

Figure 3: Residual equivalent stress after completion of first load cycle.

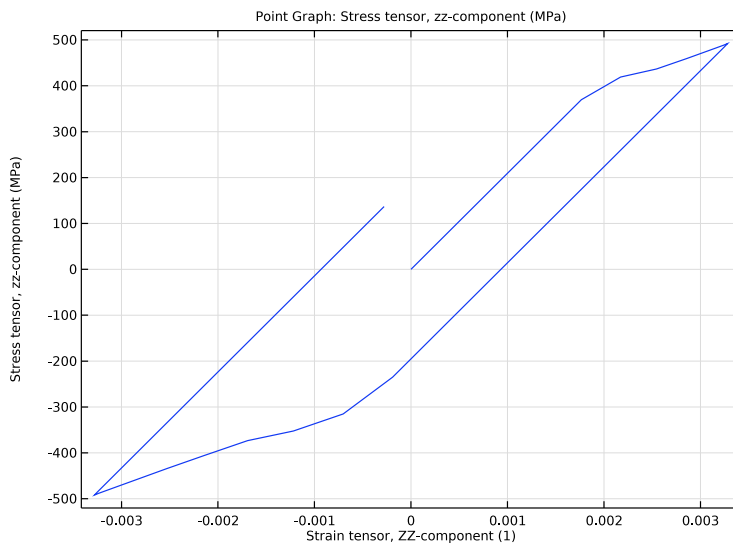

Figure 4: Stress as function of strain during the first load cycle.

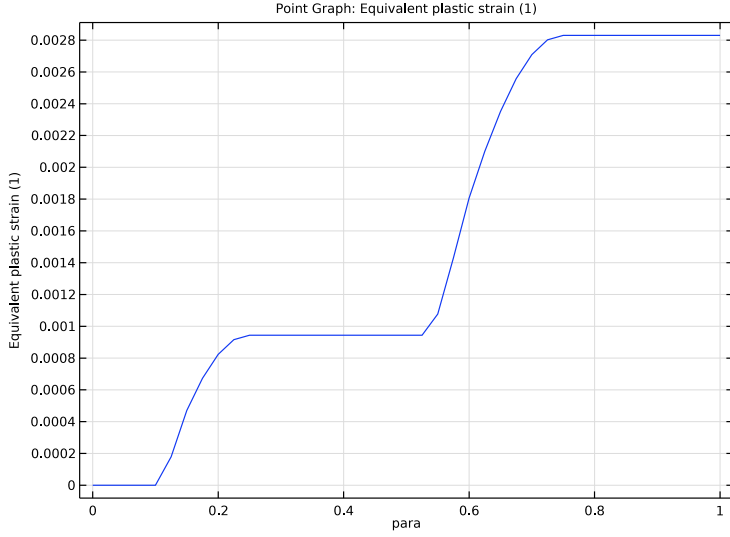

Figure 5: Accumulated equivalent plastic strain during the first load cycle.

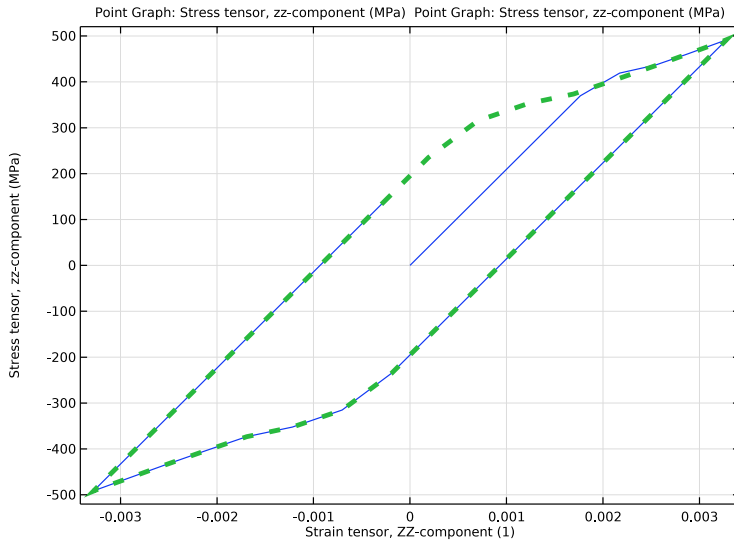

Figure 6: Stress as function of strain after two load cycles.

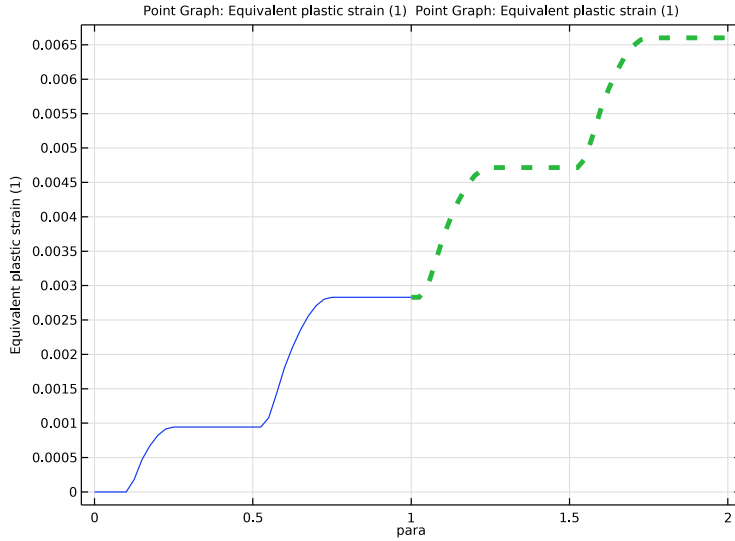

Figure 7: Accumulated equivalent plastic strain during two load cycles.

The result of the fatigue evaluation is shown in Figure 8 below. The most critical point has a computed life of approximately 7200 load cycles.

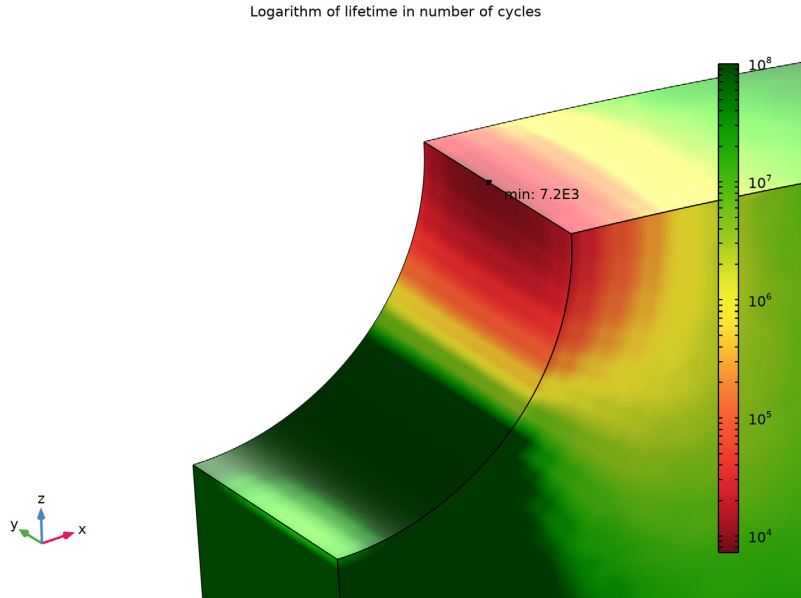

Figure 8: Lifetime plot.

Notes About the COMSOL Implementation

Two studies are used for the elastoplastic analysis. The second study contains the strain cycle that is passed on to the fatigue evaluation. It takes the results from the first study as initial conditions. This approach is not necessary, since it in the **Fatigue** study step is possible to select part of a study as defining a load cycle.

Application Library path: Fatigue_Module/Strain_Based/
cylinder_with_hole_plastic



Modeling Instructions

From the **File** menu, choose **New**.

NEW

In the **New** window, click  **Model Wizard**.

MODEL WIZARD

- 1 In the **Model Wizard** window, click  **3D**.
- 2 In the **Select Physics** tree, select **Structural Mechanics > Solid Mechanics (solid)**.
- 3 Click **Add**.
- 4 Click  **Study**.
- 5 In the **Select Study** tree, select **General Studies > Stationary**.
- 6 Click  **Done**.

GEOMETRY I

- 1 In the **Model Builder** window, under **Component 1 (comp1)** click **Geometry 1**.
- 2 In the **Settings** window for **Geometry**, locate the **Units** section.
- 3 From the **Length unit** list, choose **mm**.



Cylinder 1 (cyl1)

- 1 In the **Geometry** toolbar, click  **Cylinder**.
- 2 In the **Settings** window for **Cylinder**, locate the **Size and Shape** section.
- 3 In the **Radius** text field, type 100.
- 4 In the **Height** text field, type 100.

Cylinder 2 (cyl2)

- 1 Right-click **Cylinder 1 (cyl1)** and choose **Duplicate**.
- 2 In the **Settings** window for **Cylinder**, locate the **Size and Shape** section.
- 3 In the **Radius** text field, type 90.

Difference 1 (dif1)



- 1 In the **Geometry** toolbar, click  **Booleans and Partitions** and choose **Difference**.
- 2 Select the object **cyl1** only.
- 3 In the **Settings** window for **Difference**, locate the **Difference** section.
- 4 Click to select the  **Activate Selection** toggle button for **Objects to subtract**.
- 5 Select the object **cyl2** only.
- 6 Click  **Build All Objects**.

Cylinder 3 (cyl3)



- 1 In the **Geometry** toolbar, click  **Cylinder**.
- 2 In the **Settings** window for **Cylinder**, locate the **Size and Shape** section.
- 3 In the **Radius** text field, type 10.

- 4 In the **Height** text field, type 220.
- 5 Locate the **Position** section. In the **y** text field, type -110.
- 6 In the **z** text field, type 50.
- 7 Locate the **Axis** section. From the **Axis type** list, choose **y-axis**.
- 8 Click  **Build All Objects**.



Difference 2 (dif2)

- 1 In the **Geometry** toolbar, click  **Booleans and Partitions** and choose **Difference**.
- 2 Select the object **dif1** only.
- 3 In the **Settings** window for **Difference**, locate the **Difference** section.
- 4 Click to select the  **Activate Selection** toggle button for **Objects to subtract**.
- 5 Select the object **cyl3** only.
- 6 Click  **Build All Objects**.

Block 1 (blk1)

- 1 In the **Geometry** toolbar, click  **Block**.
- 2 In the **Settings** window for **Block**, locate the **Size and Shape** section.
- 3 In the **Width** text field, type 100.
- 4 In the **Depth** text field, type 100.
- 5 In the **Height** text field, type 50.
- 6 Click  **Build All Objects**.

Intersection 1 (int1)

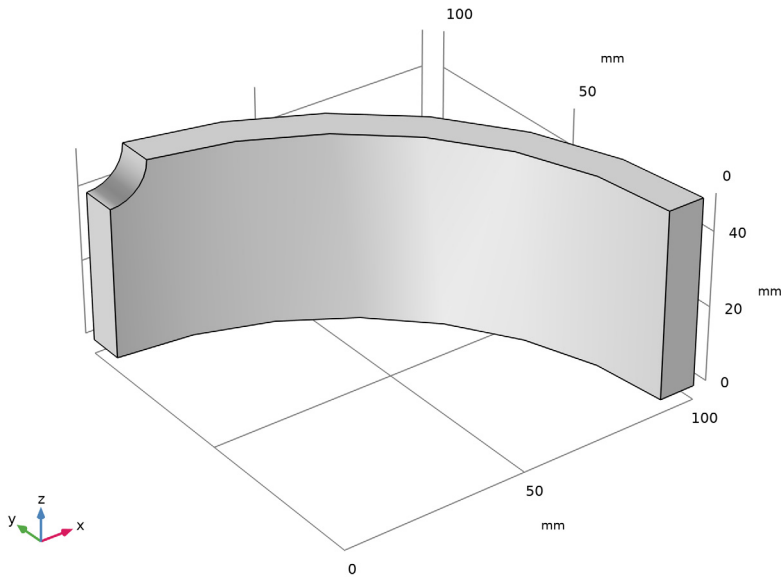

- 1 In the **Geometry** toolbar, click  **Booleans and Partitions** and choose **Intersection**.
- 2 Click in the **Graphics** window and then press Ctrl+A to select both objects.
- 3 In the **Settings** window for **Intersection**, click  **Build All Objects**.

- 4 Click the  **Zoom Extents** button in the **Graphics** toolbar.



Use an extra domain for controlling the mesh. The mesh should be fine in a region close to the hole.

Cylinder 4 (cyl4)

- 1 In the **Geometry** toolbar, click  **Cylinder**.
- 2 In the **Settings** window for **Cylinder**, locate the **Axis** section.
- 3 From the **Axis type** list, choose **y-axis**.
- 4 Locate the **Size and Shape** section. In the **Height** text field, type 40.
- 5 In the **Radius** text field, type 15.
- 6 Locate the **Position** section. In the **y** text field, type 80.
- 7 In the **z** text field, type 50.
- 8 Click  **Build All Objects**.

Intersection 2 (int2)

- 1 In the **Geometry** toolbar, click  **Booleans and Partitions** and choose **Intersection**.
- 2 Click in the **Graphics** window and then press Ctrl+A to select both objects.
- 3 In the **Settings** window for **Intersection**, locate the **Intersection** section.
- 4 Select the **Keep input objects** checkbox.

5 Click  **Build All Objects**.

Delete Entities 1 (dell)



- 1 In the **Model Builder** window, right-click **Geometry 1** and choose **Delete Entities**.
- 2 In the **Settings** window for **Delete Entities**, locate the **Entities or Objects to Delete** section.
- 3 From the **Geometric entity level** list, choose **Object**.
- 4 Select the object **cyl4** only.

Form Union (fin)

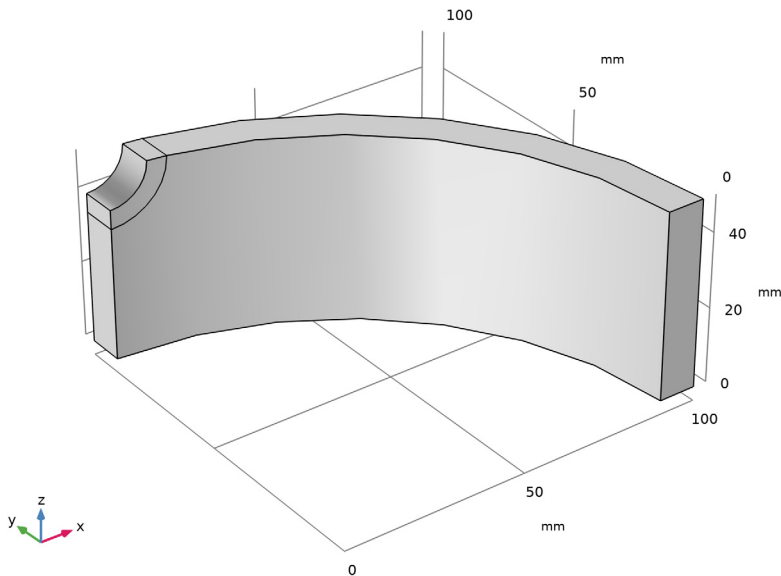
- 1 In the **Geometry** toolbar, click  **Build All**.
- 2 In the **Model Builder** window, click **Form Union (fin)**.



Mesh Control Domains 1 (mcd1)

- 1 In the **Geometry** toolbar, click  **Virtual Operations** and choose **Mesh Control Domains**.
- 2 On the object **fin**, select Domain 2 only.
- 3 In the **Geometry** toolbar, click  **Build All**.

SOLID MECHANICS (SOLID)

Symmetry I

- 1 In the **Physics** toolbar, click  **Boundaries** and choose **Symmetry**.
- 2 Select Boundaries 1, 6, and 7 only.

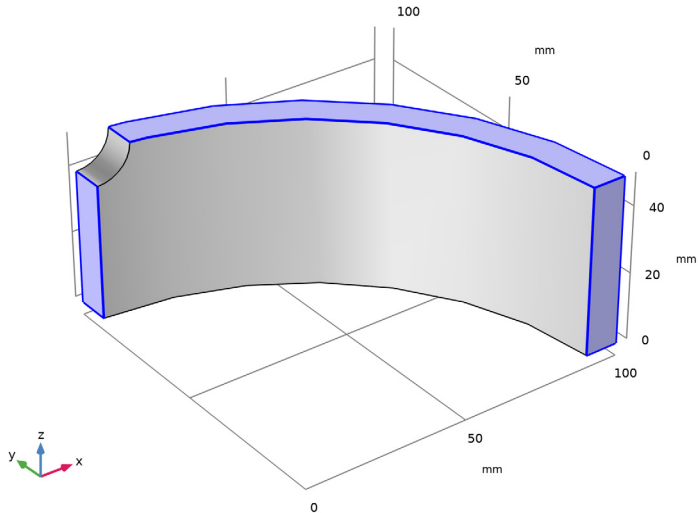

GLOBAL DEFINITIONS

Parameters I

- 1 In the **Model Builder** window, under **Global Definitions** click **Parameters I**.
- 2 In the **Settings** window for **Parameters**, locate the **Parameters** section.
- 3 In the table, enter the following settings:

Name	Expression	Value	Description
para	0	0	Load cycle control

SOLID MECHANICS (SOLID)

Boundary Load I

- 1 In the **Physics** toolbar, click  **Boundaries** and choose **Boundary Load**.
- 2 Select Boundary 3 only.
- 3 In the **Settings** window for **Boundary Load**, locate the **Force** section.

4 Specify the \mathbf{f}_A vector as

0	x
0	y
-200[MPa]*sin(2*pi*para)	z

Linear Elastic Material I

In the **Model Builder** window, click **Linear Elastic Material I**.

Plasticity I

- 1 In the **Physics** toolbar, click  **Attributes** and choose **Plasticity**.
- 2 In the **Settings** window for **Plasticity**, locate the **Plasticity Model** section.
- 3 Find the **Isotropic hardening model** subsection. From the list, choose **Perfectly plastic**.
- 4 Find the **Kinematic hardening model** subsection. From the list, choose **Linear**.

MATERIALS

Material I (mat1)

- 1 In the **Model Builder** window, under **Component 1 (comp1)** right-click **Materials** and choose **Blank Material**.
- 2 In the **Settings** window for **Material**, locate the **Material Contents** section.
- 3 In the table, enter the following settings:

Property	Variable	Value	Unit	Property group
Young's modulus	E	210 [GPa]	Pa	Young's modulus and Poisson's ratio
Poisson's ratio	nu	0.3	l	Young's modulus and Poisson's ratio
Density	rho	0	kg/m ³	Basic
Initial yield stress	sigmags	380 [MPa]	Pa	Elastoplastic material model
Kinematic tangent modulus	Ek	75 [GPa]	Pa	Elastoplastic material model

MESH 1

- 1 In the **Model Builder** window, under **Component 1 (comp1)** right-click **Mesh 1** and choose **Build All**.

The default mesh cannot resolve this problem, so you need to refine it.

Once a mesh is created the mesh control domains are removed. In order to get them back, you need to clear the mesh.

- 2 In the **Mesh** toolbar, click  **Clear Built Mesh**.
- 3 In the **Settings** window for **Mesh**, locate the **Sequence Type** section.
- 4 From the list, choose **User-controlled mesh**.

Mapped 1

- 1 In the **Mesh** toolbar, click  **More Generators** and choose **Mapped**.
- 2 Select Boundary 4 only.

Distribution 1

- 1 Right-click **Mapped 1** and choose **Distribution**.
- 2 Select Edge 4 only.
- 3 In the **Settings** window for **Distribution**, locate the **Distribution** section.
- 4 In the **Number of elements** text field, type 6.

Distribution 2

- 1 In the **Model Builder** window, right-click **Mapped 1** and choose **Distribution**.
- 2 Select Edge 5 only.
- 3 In the **Settings** window for **Distribution**, locate the **Distribution** section.
- 4 In the **Number of elements** text field, type 15.

Swept 1

- 1 In the **Mesh** toolbar, click  **Swept**.
- 2 In the **Settings** window for **Swept**, locate the **Domain Selection** section.
- 3 From the **Geometric entity level** list, choose **Domain**.
- 4 Select Domain 2 only.

Distribution 1

- 1 Right-click **Swept 1** and choose **Distribution**.
- 2 In the **Settings** window for **Distribution**, locate the **Distribution** section.
- 3 In the **Number of elements** text field, type 4.

Free Tetrahedral I

- 1 In the **Model Builder** window, under **Component 1 (comp1) > Mesh 1** right-click **Free Tetrahedral I** and choose **Move Down** twice.
- 2 Right-click **Mesh 1** and choose **Build All**.

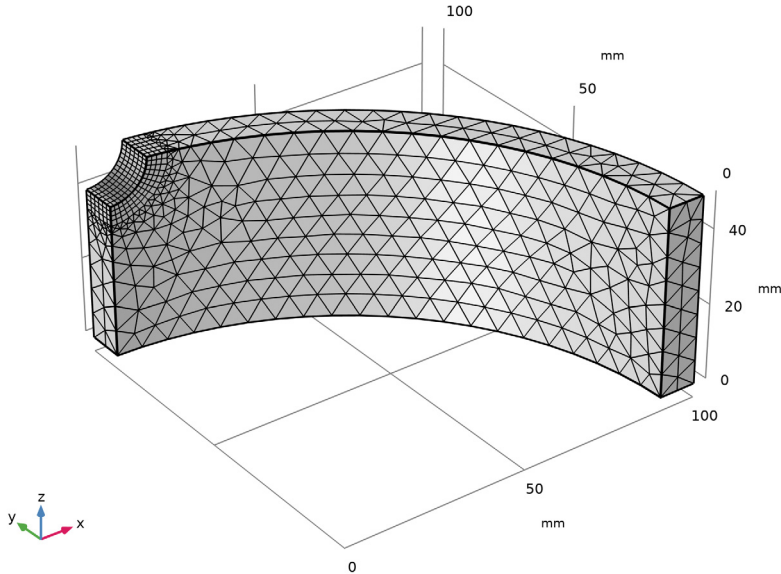

STUDY 1

Step 1: Stationary

- 1 In the **Model Builder** window, under **Study 1** click **Step 1: Stationary**.
- 2 In the **Settings** window for **Stationary**, click to expand the **Study Extensions** section.
- 3 Select the **Auxiliary sweep** checkbox.
- 4 Click **Add** to include para as continuation parameter.
- 5 In the table, enter the following settings:

Parameter name	Parameter value list
para (Load cycle control)	range(0,0.025,1)



- 6 In the **Model Builder** window, click **Study 1**.
- 7 In the **Settings** window for **Study**, type Study 1 (First Load Cycle) in the **Label** text field.

8 In the **Study** toolbar, click  **Compute**.

Set default units for result presentation.

RESULTS

Preferred Units I

- 1 In the **Results** toolbar, click  **Configurations** and choose **Preferred Units**.
- 2 In the **Settings** window for **Preferred Units**, locate the **Units** section.
- 3 Click  **Add Physical Quantity**.
- 4 In the **Physical Quantity** dialog, select **Solid Mechanics > Stress tensor (N/m²)** in the tree.
- 5 Click **OK**.
- 6 In the **Settings** window for **Preferred Units**, locate the **Units** section.
- 7 In the table, enter the following settings:

Quantity	Unit	Preferred unit
Stress tensor	N/m ²	MPa

- 8 Click  **Apply**.

Stress (solid)

- 1 In the **Model Builder** window, under **Results** click **Stress (solid)**.
- 2 In the **Stress (solid)** toolbar, click  **Plot**.

The default plot is from the last parameter value, which has no external loads. The residual stress and corresponding displacements are shown. You may want to reduce the deformation scale in order to get a better view.

Volume I

In the **Model Builder** window, expand the **Stress (solid)** node.

Deformation

- 1 In the **Model Builder** window, expand the **Volume I** node, then click **Deformation**.
- 2 In the **Settings** window for **Deformation**, locate the **Scale** section.
- 3 Select the **Scale factor** checkbox. In the associated text field, type 2000.
- 4 In the **Stress (solid)** toolbar, click  **Plot**.

Now, set back scaling to the default and examine the stress state at maximum tension.
- 5 Clear the **Scale factor** checkbox.



Stress (solid)

- 1 In the **Model Builder** window, under **Results** click **Stress (solid)**.
- 2 In the **Settings** window for **3D Plot Group**, locate the **Data** section.
- 3 From the **Parameter value (para)** list, choose **0.25**.
- 4 In the **Stress (solid)** toolbar, click  **Plot**.

Plastic Strain

- 1 In the **Results** toolbar, click  **ID Plot Group**.
- 2 In the **Settings** window for **ID Plot Group**, type Plastic Strain in the **Label** text field.



Point Graph 1

- 1 In the **Plastic Strain** toolbar, click  **Point Graph**.
- 2 Select Point 6 only.
- 3 In the **Settings** window for **Point Graph**, click **Replace Expression** in the upper-right corner of the **y-Axis Data** section. From the menu, choose **Component 1 (comp1) > Solid Mechanics > Strain > solid.epGp - Equivalent plastic strain - I**.
- 4 In the **Plastic Strain** toolbar, click  **Plot**.



Stress vs. Strain

- 1 In the **Results** toolbar, click  **ID Plot Group**.
- 2 In the **Settings** window for **ID Plot Group**, type Stress vs. Strain in the **Label** text field.

Point Graph 1

- 1 In the **Stress vs. Strain** toolbar, click  **Point Graph**.
- 2 Select Point 6 only.
- 3 In the **Settings** window for **Point Graph**, click **Replace Expression** in the upper-right corner of the **y-Axis Data** section. From the menu, choose **Component 1 (comp1) > Solid Mechanics > Stress > Stress tensor (spatial frame) - N/m² > solid.sGpzz - Stress tensor, zz-component**.
- 4 Click **Replace Expression** in the upper-right corner of the **x-Axis Data** section. From the menu, choose **Component 1 (comp1) > Solid Mechanics > Strain > Strain tensor (material and geometry frames) > solid.eZZ - Strain tensor, ZZ-component**.
- 5 In the **Stress vs. Strain** toolbar, click  **Plot**.
Add another study for the next load cycle.

ADD STUDY

- 1 In the **Home** toolbar, click  **Add Study** to open the **Add Study** window.
- 2 Go to the **Add Study** window.
- 3 Find the **Studies** subsection. In the **Select Study** tree, select **General Studies > Stationary**.
- 4 Click the **Add Study** button in the window toolbar.
- 5 In the **Home** toolbar, click  **Add Study** to close the **Add Study** window.

STUDY 2

Step 1: Stationary

- 1 In the **Settings** window for **Stationary**, locate the **Study Extensions** section.
- 2 Select the **Auxiliary sweep** checkbox.
- 3 Click  **Add**.
- 4 In the table, enter the following settings:

Parameter name	Parameter value list
para (Load cycle control)	range(1,0.025,2)

- 5 Click to expand the **Values of Dependent Variables** section. Find the **Initial values of variables solved for** subsection. From the **Settings** list, choose **User controlled**.
- 6 From the **Method** list, choose **Solution**.
- 7 From the **Study** list, choose **Study 1 (First Load Cycle), Stationary**.
- 8 In the **Model Builder** window, click **Study 2**.
- 9 In the **Settings** window for **Study**, type **Study 2 (Steady State Load Cycle)** in the **Label** text field.
- 10 Locate the **Study Settings** section. Clear the **Generate default plots** checkbox.
- 11 In the **Study** toolbar, click  **Compute**.

RESULTS

Point Graph 2



- 1 In the **Model Builder** window, under **Results > Plastic Strain** right-click **Point Graph 1** and choose **Duplicate**.
- 2 In the **Settings** window for **Point Graph**, locate the **Data** section.
- 3 From the **Dataset** list, choose **Study 2 (Steady State Load Cycle)/Solution 2 (sol2)**.

- 4 Click to expand the **Coloring and Style** section. Find the **Line style** subsection. From the **Line** list, choose **Dotted**.
- 5 From the **Width** list, choose **4**.
- 6 In the **Plastic Strain** toolbar, click  **Plot**.

Point Graph 2

- 1 In the **Model Builder** window, under **Results > Stress vs. Strain** right-click **Point Graph 1** and choose **Duplicate**.
- 2 In the **Settings** window for **Point Graph**, locate the **Data** section.
- 3 From the **Dataset** list, choose **Study 2 (Steady State Load Cycle)/Solution 2 (sol2)**.
- 4 Locate the **Coloring and Style** section. Find the **Line style** subsection. From the **Line** list, choose **Dotted**.
- 5 From the **Width** list, choose **4**.
- 6 In the **Stress vs. Strain** toolbar, click  **Plot**.

ADD PHYSICS

- 1 In the **Home** toolbar, click  **Add Physics** to open the **Add Physics** window.
- 2 Go to the **Add Physics** window.
- 3 In the tree, select **Structural Mechanics > Fatigue (ftg)**.
- 4 Find the **Physics interfaces in study** subsection. In the table, clear the **Solve** checkboxes for **Study 1 (First Load Cycle)** and **Study 2 (Steady State Load Cycle)**.
- 5 Click the **Add to Component 1** button in the window toolbar.
- 6 In the **Home** toolbar, click  **Add Physics** to close the **Add Physics** window.

FATIGUE (FTG)

Strain-Based 1

- 1 In the **Physics** toolbar, click  **Boundaries** and choose **Strain-Based**.
- 2 In the **Settings** window for **Strain-Based**, locate the **Boundary Selection** section.
- 3 From the **Selection** list, choose **All boundaries**.
- 4 Locate the **Solution Field** section. From the **Physics interface** list, choose **Solid Mechanics (solid)**.
- 5 Locate the **Evaluation Settings** section. Find the **Critical plane settings** subsection. In the **Q** text field, type 16.



MATERIALS

Material 2 (mat2)

- 1 In the **Model Builder** window, under **Component 1 (comp1)** right-click **Materials** and choose **Blank Material**.
- 2 In the **Settings** window for **Material**, locate the **Geometric Entity Selection** section.
- 3 From the **Geometric entity level** list, choose **Boundary**.
- 4 From the **Selection** list, choose **All boundaries**.
- 5 Locate the **Material Contents** section. In the table, enter the following settings:

Property	Variable	Value	Unit	Property group
Fatigue ductility coefficient	epsilonfn_CM	0.375	1	Coffin-Manson
Fatigue ductility exponent	c_CM	-0.60	1	Coffin-Manson
Fatigue strength coefficient	sigmaf_Basquin	1323 [MPa]	Pa	Basquin
Fatigue strength exponent	b_Basquin	-0.097	1	Basquin
Young's modulus	E	210 [GPa]	Pa	Basic

ADD STUDY

- 1 In the **Home** toolbar, click  **Add Study** to open the **Add Study** window.
- 2 Go to the **Add Study** window.
- 3 Find the **Physics interfaces in study** subsection. In the table, clear the **Solve** checkbox for **Solid Mechanics (solid)**.
- 4 Find the **Studies** subsection. In the **Select Study** tree, select **Preset Studies for Selected Physics Interfaces > Fatigue**.
- 5 Click the **Add Study** button in the window toolbar.
- 6 In the **Home** toolbar, click  **Add Study** to close the **Add Study** window.

STUDY 3

Step 1: Fatigue

- 1 In the **Settings** window for **Fatigue**, locate the **Values of Dependent Variables** section.
- 2 Find the **Values of variables not solved for** subsection. From the **Settings** list, choose **User controlled**.
- 3 From the **Method** list, choose **Solution**.

- 4 From the **Study** list, choose **Study 2 (Steady State Load Cycle), Stationary**.
- 5 In the **Model Builder** window, click **Study 3**.
- 6 In the **Settings** window for **Study**, type Study 3 (Fatigue, SWT) in the **Label** text field.
- 7 In the **Study** toolbar, click  **Compute**.

RESULTS

Fatigue Life

- 1 In the **Settings** window for **3D Plot Group**, type Fatigue Life in the **Label** text field.
- 2 Click to expand the **Title** section. From the **Title type** list, choose **Manual**.
- 3 In the **Title** text area, type Logarithm of lifetime in number of cycles.
- 4 In the **Model Builder** window, expand the **Fatigue Life** node.

Marker 1

- 1 In the **Model Builder** window, expand the **Results > Fatigue Life > Surface 1** node, then click **Marker 1**.
- 2 In the **Settings** window for **Marker**, locate the **Text Format** section.
- 3 In the **Precision** text field, type 2.
- 4 In the **Fatigue Life** toolbar, click  **Plot**.